Photosynthesis

VOLUME I

Energy Conversion by Plants and Bacteria

Edited by

GOVINDJEE

*Departments of Botany
and Physiology and Biophysics
University of Illinois at Urbana-Champaign
Urbana, Illinois*



ACADEMIC PRESS 1982

A Subsidiary of Harcourt Brace Jovanovich, Publishers

New York London

Paris San Diego San Francisco São Paulo Sydney Tokyo Toronto

COPYRIGHT © 1982, BY ACADEMIC PRESS, INC.

ALL RIGHTS RESERVED.

NO PART OF THIS PUBLICATION MAY BE REPRODUCED OR TRANSMITTED IN ANY FORM OR BY ANY MEANS, ELECTRONIC OR MECHANICAL, INCLUDING PHOTOCOPY, RECORDING, OR ANY INFORMATION STORAGE AND RETRIEVAL SYSTEM, WITHOUT PERMISSION IN WRITING FROM THE PUBLISHER.

ACADEMIC PRESS, INC.

111 Fifth Avenue, New York, New York 10003

United Kingdom Edition published by
ACADEMIC PRESS, INC. (LONDON) LTD.
24/28 Oval Road, London NW1 7DX

Library of Congress Cataloging in Publication Data

Main entry under title:

Photosynthesis: Energy conversion by plants and bacteria.

v. 1. Cell biology.

Includes bibliographies and index.

1. Photosynthesis. 2. Bacteria, Photosynthetic.

Govindjee, Datta. II. Series. III. Series:

Cell biology.

QK882.P546 1982, vol. 1 581.1'3342s 82-8701

ISBN 0-12-294301-5 (v. 1) [581.1'3342] AACR2

PRINTED IN THE UNITED STATES OF AMERICA

82 83 84 85 9 8 7 6 5 4 3 2 1

*I am especially indebted to my daughter
ANITA GOVINDJEE
for her technical and editorial assistance
during the preparation of this volume.*

Contents

List of Contributors	xv
Preface	xvii
Bessel Kok (1918–1979): A Tribute, by George Cheniae and Jack Myers	xxi

I Introduction

1

Introduction to Photosynthesis: Energy Conversion by Plants and Bacteria	1
GOVINDJEE and JOHN WHITMARSH	

I. Introduction	2
II. Basic Concepts from Earlier Work	5
III. Concluding Remarks	11
IV. Literature	11
References	12

2

Current Attitudes in Photosynthesis Research	17
COLIN A. WRAIGHT	

I. Introduction	19
II. Reaction Centers	21
III. Electron Transfer Out of the Reaction Center	28

IV. The Electron Transport Chain	33
V. Energy Transduction	44
VI. Structure and Organization of the Photosynthetic Apparatus	48
VII. Phylogenetic and Metabolic Comparison in Photosynthesis	51
VIII. Concluding Remarks	54
References	55

II Structure and Function

3

Photosynthetic Membrane Structure and Function

65

SAMUEL KAPLAN and CHARLES J. ARNTZEN

I. Introduction	67
II. Photosynthetic Bacteria	71
III. Chloroplasts	109
IV. Conclusions	140
References	140

4

Orientation of Photosynthetic Pigments *in Vivo*

153

JACQUES BRETON and ANDRÉ VERMEGLIO

I. Introduction	155
II. Methodology	157
III. Relative Orientation of Pigments within Isolated Photosynthetic Complexes	166
IV. Orientation of Pigments with Respect to the Membrane Plane	178
V. Local Order between Complexes in Photosynthetic Membranes	187
VI. Conclusions	188
References	190

5

Reaction Centers

195

MELVIN Y. OKAMURA, GEORGE FEHER, and NATHAN NELSON

I. Introduction	197
II. Photosynthetic Bacteria	203
III. Green Plant Photosystems	229
IV. Concluding Remarks	256
V. Appendix	262
References	264

III Primary Photochemistry

6

**Electronic Structure and Function of Chlorophylls
and Their Pheophytins**

275

LESTER L. SHIPMAN

I. Introduction	276
II. Chemical Structures	276
III. Self-Consistent Field Calculations	277
IV. Canonical Molecular Orbitals	278
V. <i>Configuration Interaction Calculations</i>	281
VI. Singlet States	282
VII. Triplet States	287
VIII. Cation Radical States	288
References	291

7

Chlorophyll Singlet Excitons

293

ROBERT M. PEARLSTEIN

I. Introduction	294
II. Exciton Effects in Steady State Optical Spectra	295
III. Exciton States of Antenna Chlorophyll-Proteins	302
IV. Exciton Migration from Antenna to Reaction Center	309

V. Exciton Effects in Picosecond Optical Spectra	323
VI. Exciton Effects within Reaction Center Complexes	323
References	327

8

Primary Photochemical Reactions

331

WILLIAM W. PARSON and BACON KE

I. Introduction: General Considerations	332
II. Photosynthetic Bacteria	339
III. Green Plants	354
References	379

IV Electron Transport

9

Electron and Proton Transport

387

WILLIAM A. CRAMER and ANTONY R. CROFTS

I. Introduction	389
II. Mechanism of Electron Transfer	391
III. Properties of Quinones	398
IV. Primary and Secondary Quinone Acceptors	404
V. Cytochromes	418
VI. The Electron Donors to P700 and P870	431
VII. Vectorial Electron Transport	435
VIII. Protolytic Reactions	449
References	457

10

Oxygen Evolution in Photosynthesis

469..

THOMAS J. WYDRZYNSKI

I. Introduction	470
II. Substrate	470
III. Energetics	472

IV. Kinetics	473
V. Chemistry	489
References	500

11

Thermoluminescence from Photosynthetic Apparatus

YORINAO INOUE and KAZUO SHIBATA

I. Introduction	508
II. Glow Curves	509
III. Characteristics of Bands	514
IV. Origin of Charges	521
V. Temperature-Jump Luminescence	531
References	531

V Photophosphorylation

12

Mechanism of ATP Synthesis

DONALD R. ORT and BRUNO A. MELANDRI

I. Chemiosmotic Coupling	539
II. Structural Organization of Coupling Reactions and Components	550
III. The Transmembrane Electrochemical Hydrogen Ion Gradient	555
IV. Stoichiometries of Photosynthetic Energy Conversion	571
References	583

13

The Development of Electrochemical Potential Gradient across Photosynthetic Membranes

WOLFGANG JUNGE and J. BAZ JACKSON

I. Introduction	590
II. The Membrane	594

III. Measurement of Membrane Potential	598
IV. Electrogenic Reactions in Thylakoids and Chromatophores	609
V. Protolytic Reactions in Thylakoids and Chromatophores	626
VI. Concluding Remarks	634
References	639

14

Proton Translocating ATPases of Photosynthetic Membranes

647

RICHARD E. McCARTY and CHANOCH CARMELI

I. Introduction	648
II. Function of ATPase Complexes	650
III. Structure of ATPase Complexes	657
IV. ATPase Activity of Coupling Factors	670
V. Nucleotide Binding and Conformational Changes	681
VI. Postulated Mechanisms	688
References	690

VI Biosynthesis of Pigments

15

Biosynthesis of Pigments in Plants and Bacteria

699

CONSTANTIN A. REBEIZ and JUNE LASCELLES

I. Introduction	702
II. Detection, Putative Structure, and Distribution of Different Chlorophyll <i>a</i> and <i>b</i> in Green Plants	703
III. Structure, Distribution, and Function of Bacterial Tetrapyrroles	721
IV. Formation of the Chlorophyll <i>a</i> Pool in Green Plants	725
V. Formation of the Chlorophyll <i>b</i> Pool in Green Plants	756
VI. Regulation of the Chlorophyll Biosynthetic Pathway	757

VII. Synthesis of Hemes and Bacteriochlorophyll in Photosynthetic Bacteria	759
VIII. Regulation of Bacteriochlorophyll Synthesis	767
IX. Synthesis of Phycobilins	770
X. Formation of Prenylipids (Including Carotenoids)	771
References	772
Index	781

List of Contributors

Numbers in parentheses indicate the pages on which the authors' contributions begin.

- CHARLES ARNTZEN (65), Plant Research Laboratory, Michigan State University, East Lansing, Michigan 48824
- JACQUES BRETON (153), Service de Biophysique, Département de Biologie, Centre d'Études Nucléaires de Saclay, Commissariat à l'Énergie Atomique, 91191 Gif-Sur-Yvette Cédex, France
- CHANOCH CARMELI (647), Department of Biochemistry, George S. Wise Faculty of Life Sciences, University of Tel Aviv, Ramat Aviv, Tel Aviv 69978, Israel
- GEORGE CHENIAE (xxi), Department of Agronomy, University of Kentucky, Lexington, Kentucky 40546
- WILLIAM A. CRAMER (387), Department of Biological Sciences, Lilly Hall of Life Sciences, Purdue University, West Lafayette, Indiana 47907
- ANTONY R. CROFTS (387), Department of Physiology and Biophysics, University of Illinois at Urbana-Champaign, Urbana, Illinois 61801
- GEORGE FEHER (195), Department of Physics, University of California at San Diego, La Jolla, California 92093
- GOVINDJEE (1), Departments of Botany, and Physiology and Biophysics, University of Illinois at Urbana-Champaign, Urbana, Illinois 61801
- YORINAO INOUE (507), Laboratory of Plant Physiology, Solar Energy Project, The Institute of Physical and Chemical Research, Rikagaku Kenkyusho, Hirosawa, Wako-shi, Saitama-351, Japan
- J. BAZ JACKSON (589), Department of Biochemistry, The University of Birmingham, Birmingham B15 2TT, England
- WOLFGANG JUNGE (589), Fachbereich Biologie/Chemie, Schwerpunkt Biophysik, Universität Osnabrück, Osnabrück, West Germany
- SAMUEL KAPLAN (65), Department of Microbiology, University of Illinois at Urbana-Champaign, Urbana, Illinois 61801
- BACON KE (331), Charles F. Kettering Research Laboratory, Yellow Springs, Ohio 45387

- JUNE LASCELLES (699), Department of Microbiology, University of California, Los Angeles, Los Angeles, California 90024
- RICHARD E. McCARTY (647), Section of Biochemistry, Molecular and Cell Biology, Division of Biological Sciences, Cornell University, Ithaca, New York 14853
- BRUNO A. MELANDRI (537), Chair of Molecular Biology, Istituto ed Orto Botanico, Università di Bologna, 40126 Bologna, Italy
- JACK MYERS (xxi), Department of Zoology, The University of Texas at Austin, Austin, Texas 78712
- NATHAN NELSON (195), Department of Biology, Israel Institute of Technology, Technion City, Haifa, Israel
- MELVIN Y. OKAMURA (195), Department of Physics, University of California at San Diego, La Jolla, California 92093
- DONALD R. ORT (537), Department of Botany, University of Illinois at Urbana-Champaign, Urbana, Illinois 61801
- WILLIAM W. PARSON (331), Department of Biochemistry, University of Washington, Seattle, Washington 98195
- ROBERT M. PEARLSTEIN (293), Organic and Polymer Chemistry Section, Battelle Columbus Laboratories, Columbus, Ohio 43201
- CONSTANTIN A. REBEIZ (699), Department of Horticulture, University of Illinois at Urbana-Champaign, Urbana, Illinois 61801
- KAZUO SHIBATA (507), The Institute of Physical and Chemical Research, Rikagaku Kenkyusho, Hirosawa, Wako-shi, Saitama-351, Japan
- LESTER L. SHIPMAN* (275), Chemistry Division, Argonne National Laboratory, Argonne, Illinois 60439
- ANDRÉ VERMEGLIO (153), Service de Biophysique, Département de Biologie, Centre d'Études Nucléaires de Saclay, Commissariat à l'Énergie Atomique, 91191 Gif-Sur-Yvette Cédex, France
- JOHN WHITMARSH (1), Department of Botany, University of Illinois at Urbana-Champaign, Urbana, Illinois 61801
- COLIN A. WRAIGHT (17), Departments of Physiology and Biophysics, and Botany, University of Illinois at Urbana-Champaign, Urbana, Illinois 61801
- THOMAS J. WYDRZYNSKI (469), Standard Oil Company (Indiana), AMOCO Research Center, Naperville, Illinois 60566

**Present address:* Central Research and Development Department, Experimental Station, E. I. DuPont de Nemours and Co., Inc., Wilmington, Delaware 19898

Preface

Sunlight is a plentiful, continuously available source of energy. Photosynthesis converts this radiant energy into chemical energy in a highly efficient manner. Plants and cyanobacteria use water as a hydrogen donor and produce oxygen as a by-product; energy is stored in complex organic molecules. Photosynthetic bacteria use chemicals such as H_2S as their hydrogen donors. Hence, they do not produce oxygen as a by-product. In plants, there is a noncyclic electron flow from water to nicotinamide adenine dinucleotide phosphate ($NADP^+$) producing NADPH and adenosine triphosphate (ATP). In photosynthetic bacteria, except, perhaps, in green bacteria, there is a cyclic electron flow producing ATP; the pyridine nucleotide, nicotinamide adenine dinucleotide (NAD^+), is reduced through reversed (uphill) electron flow by utilizing ATP and the externally added hydrogen donors. The complete sequence of the conversion of light energy into the production of ATP and NADPH (or NADH) in both plants and bacteria is the subject of this volume. The uniqueness of this volume lies in its integrated approach to both plant and bacterial photosynthesis. A separate volume (*Photosynthesis: Development, Carbon Metabolism, and Plant Productivity*, Vol. II) includes discussion on how ATP and NADPH are used to fix carbon dioxide into organic compounds and on the relationship between photosynthesis and plant productivity.

The contributors discuss the various aspects of the energy conversion process in both plants and bacteria in an integrated fashion, except, of course, when they deal with a process unique to one system. Most chapters have two authors—one an expert in plant photosynthesis and the other in bacterial photosynthesis. This volume emphasizes the biochemical and biophysical aspects of photosynthesis. It also contains a review of the historical development of major concepts, analysis of experimental data, and an exposition of recent findings. Since both background and up-to-date information is included, the book will serve not only as a reference source for researchers but also as an introductory work for

graduate and advanced undergraduate students in cell biology, plant physiology, biochemistry, and biophysics.

It is our belief that a basic understanding of photosynthesis is needed before we can use it to improve the overall rate of photosynthesis of a single plant or learn how to build photosynthesis-based artificial devices to convert light energy efficiently into electrical and chemical energy.

The reader is encouraged to read both Chapters 1 and 2 before going on to the later ones, since Chapter 1, in addition to introducing the various chapters briefly, presents some of the past concepts, and Chapter 2 discusses the current attitudes in research and presents a comparative biophysical chemistry of both plants and bacteria.

GOVINDJEE

Acknowledgments

I am grateful to my wife, Rajni, and my children, Anita and Sanjay, for their patience during the preparation of this book. I am thankful to my past graduate students for having provided me with an intellectual atmosphere for photosynthesis research, long before this book was ever planned: Maarib Bazzaz, Glenn Bedell, Fred Cho, Paul Jursinic, Rita Khanna, Ted Mar, Prasanna Mohanty, John Munday, George Pappageorgiou, Alan Stemler, David vanderMeulen, Daniel Wong, Tom Wydrzynski, and Barbara Zilinskas. My present graduate students (Danny Blubaugh, William Coleman, Julian Eaton-Rye, and James Fenton) deserve my gratitude for not complaining when I was busy preparing this volume. I am also thankful to Shubha Govind, Wim F. J. Vermaas, Christa Critchley, and Ion Baianu for their cooperation. The courtesy extended by the personnel in the Department of Physiology and Biophysics, particularly by Nan Miller and Margaret McWhorter, is gratefully acknowledged.

Thanks are due to all the contributors for writing excellent chapters for this volume. I wish to thank Tony Crofts, Don DeVault, Tom Ebrey, Herb Gutowsky, Don Ort, Gregorio Weber, and John Whitmarsh for discussions on photosynthesis and related topics.

Bessel Kok (1918–1979): A Tribute

Bessel Kok was born and educated in Holland, receiving the degrees of Candidate in Natural Philosophy in 1938, Doctor of Natural Philosophy in 1941 from the University of Leiden, and the Ph.D. in biophysics at the University of Utrecht in 1948. While pursuing his Ph.D. he worked in Utrecht for a distilling company where he became acting manager.

From 1949 to 1958, he worked for the Dutch Central Organization for Applied Research (T.N.O.) at the University of Wageningen (except during 1951–1952, when he was a Fellow at the Carnegie Institute of Washington at Stanford, California).

In 1958, Bessel became director of the Bioscience Group of the Research Institute for Advanced Studies (RIAS) in Baltimore, Maryland. He was subsequently promoted to the rank of associate director of research of this Martin-Marietta-sponsored laboratory and served in this capacity until his untimely death on April 27, 1979.

Bessel's scientific accomplishments were celebrated by a number of awards, including the C. F. Kettering Award (1972), the Stephen Hales Prize (1978) of the American Society of Plant Physiologists, and election to membership (1974) in the United States National Academy of Sciences.

Of the many aspects of research on the process of photosynthesis there are few which do not bear some imprint left by Bessel Kok. His work yielded more than 100 publications over 31 years. However, the number of publications is less distinctive than the critical character of the questions addressed and the results obtained.

Bessel's dissertation was a critical study of the quantum yield of photosynthesis and its measurement. In the course of that work he discovered the partial suppression of dark respiration by light, which came to be called the *Kok Effect*. In the early 1950s he made in-depth studies of solar energy conversion by algae in the context of mass culture as a potential source of food. For the maximum conversion efficiency of light to algal cell material his measured value of 20% stands as a benchmark.

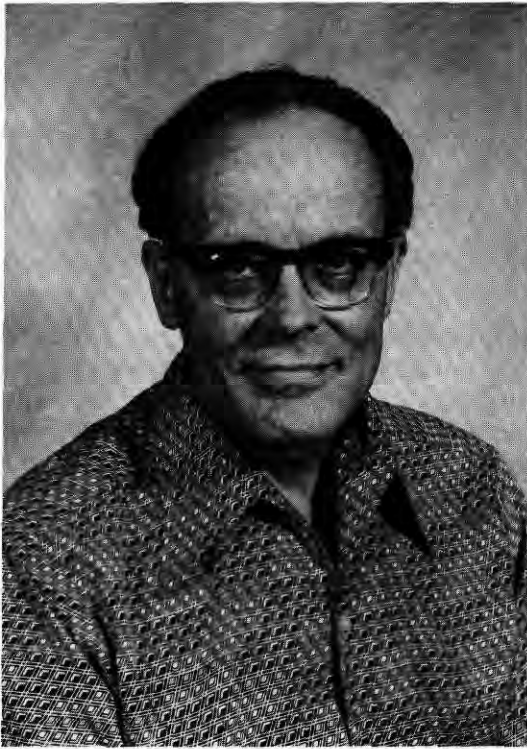

Bessel Kok

Interest in intermittency light effects on yields in mass culture led to the study of flashing light at a time when there were divergent data and interpretations for the O_2 flash yield. Elegant experimentation revealed the effect of flash duration on flash yield and eliminated the then current doubts on the conceptual validity of the photosynthetic unit.

The concept of the photosynthetic unit led to the prediction of an *ultimate photoreceptor*. Bessel's search for it by increasingly more sophisticated experimentation led to his discovery and characterization of P700, a milestone in work on the primary reactions of photosynthesis. Study of the reversible bleaching of P700 by different actinic wavelengths provided evidence for the proposal of Kok and George Hoch, made almost simultaneously with that of Robert Hill and Fay Bendall, for two photoreactions interacting in what has come to be called the *Z-scheme*. There followed widely ranging work on pool sizes, component interaction, and transfer times of electron carriers linking the two photoreactions. Collaboration with Pierre and Anne Joliot added O_2 evolution as a kinetic

measure of events between photosystems I and II and led subsequently to extension of the Joliot's observations on O_2 yields from single flashes. From this emerged the clearly proposed and generally accepted cyclic four-step model for O_2 evolution, in Bessel's language the *oxygen clock*. A development of techniques followed which allowed critical measurements of H^+/e^- accompanying O_2 evolution and the e^- -transfer steps between the photoacts. Almost obscured by the rapid pace of these exciting achievements was the development of mass spectrometric measurements applied to the interactions between photosynthesis and respiration and to an extraterrestrial life-detection system.

Undoubtedly our abridged account is incomplete, especially in its recognition of Bessel's many collaborators. Our intent was to sketch his scientific history in order that we might turn to more personal thoughts.

As a practitioner of science, Bessel was distinguished by his creativity. His keen and imaginative mind was guided into complex problems by a remarkable intuition. Identifying and finding the *nuggets* (his word) allowed simplification of a complex picture to its bare essentials. Such was his art. He often claimed that his successes came from *gadgeteering*. In perspective, however, one might say that his science was the product of artistry, craftsmanship, and intensity of effort.

Bessel's scientific accomplishments reveal too little of a unique character that had many facets. Some may have seen only the outer veneer as a brusque and, at times, even boorish personality. Some have felt his patience and his sensitivity to all people, whatever their walk in life. Some have seen his intolerance of the trappings or of the pomp and ceremony of science. Some have enjoyed him as a witty and boisterous drinking companion.

Bessel was an uncommonly dedicated man, dedicated to his family, to his science, and to the joys of life. He pursued each endeavor with unrelenting fervor and passion and with enormous mental and physical stamina. He wore only a thin cloak of inhibitions, happily shared warmth and encouragement, but also gave sharp and sometimes brutal criticisms. His standards for his own work were uncompromisingly high, and he expected as much from others. Many of us earned his criticisms, some experienced his praise and encouragement, but all of us learned from Bessel.

On behalf of all of the authors, the editor of this volume, and many others, we salute and toast you, Bessel, for your scientific accomplishment, for your free spirit, and for all the fond personal remembrances you gave us.

GEORGE CHENIAE
JACK MYERS

Contents of Volume II

List of Contributors	xiii
Preface	xv
Hans Gaffron (1902–1979): A Tribute, by Martin Kamen	xxi
Hans Gaffron, 1902–1979, by Norman I. Bishop	xxiii

1

Introduction to Photosynthesis: Carbon Assimilation and Plant Productivity	1
ARCHIE R. PORTIS, JR.	

2

Introduction to Genetics and Molecular Biology of Photosynthetic Bacteria, Cyanobacteria and Chloroplasts	13
VENETIA A. SAUNDERS and DENNIS E. BUETOW	

3

Genetics and Molecular Biology of Photosynthetic Bacteria and Cyanobacteria	17
VENETIA A. SAUNDERS	

4

Molecular Biology of Chloroplasts	43
DENNIS E. BUETOW	

5	<hr/>	
	Biogenesis of the Photosynthetic Apparatus in Prokaryotes and Eukaryotes	89
	ITZHAK OHAD and GERHART DREWS	
6	<hr/>	
	Carbon Dioxide Fixation Pathways in Plants and Bacteria	141
	JAMES A. BASSHAM and BOB B. BUCHANAN	
7	<hr/>	
	Photorespiration	191
	WILLIAM L. OGREN and RAYMOND CHOLLET	
8	<hr/>	
	Crassulacean Acid Metabolism (CAM)	231
	MANFRED KLUGE	
9	<hr/>	
	Environmental Regulation of Photosynthesis	263
	JOSEPH A. BERRY and W. JOHN S. DOWNTON	
10	<hr/>	
	Translocation of Photosynthate	345
	DONALD R. GEIGER and ROBERT T. GIAQUINTA	
11	<hr/>	
	Predicting Photosynthesis	387
	JOHN D. HESKETH, JOSEPH T. WOOLLEY, and DOYLE B. PETERS	
12	<hr/>	
	Prospects of Applying Knowledge of Photosynthesis toward Improving Crop Production	419
	ROGER M. GIFFORD and COLIN L. D. JENKINS	

13

**Global Photosynthesis in Relation to
Our Food and Energy Needs**

459

ROGER M. GIFFORD

Special Topics

14

Canopy Photosynthesis and Yield in Soybean

499

A. LAWRENCE CHRISTY and CLARK A. PORTER

15

**The Functional Role of Bicarbonate
in Photosynthetic Light Reaction II**

513

ALAN STEMLER

16

**Bicarbonate or Carbon Dioxide as a Requirement
for Efficient Electron Transport
on the Acceptor Side of Photosystem II**

541

WIM F. J. VERMAAS and GOVINDJEE

Index

559

Part I

Introduction

Introduction to Photosynthesis: Energy Conversion by Plants and Bacteria

GOVINDJEE
JOHN WHITMARSH

I. Introduction.....	2
II. Basic Concepts from Earlier Work.....	4
A. Photosynthetic Unit and Two Light Reactions.....	5
B. Oxygen Evolution.....	8
C. Photophosphorylation.....	9
D. Light Emission.....	9
E. Carbon Fixation and Photorespiration.....	10
III. Concluding Remarks.....	11
IV. Literature.....	11
References.....	12

ABBREVIATIONS

ADP (ATP)	Adenosine di (tri) phosphate
BChl	Bacteriochlorophyll
Chl	Chlorophyll
Cyt	Cytochrome
ESR	Electron spin (paramagnetic) resonance
NAD ⁺ (NADP ⁺)	Nicotinamide adenine dinucleotide (phosphate)
NMR	Nuclear magnetic resonance
PS	Photosystem
RC	Reaction center

ABSTRACT

In photosynthesis, plants, cyanobacteria, and photosynthetic bacteria use absorbed radiant energy to drive the synthesis of a variety of chemicals. In this process, energy liberated in the fusion of hydrogen in the sun is stored within a period of 10 min of its release in a chemically stable form that can last for hundreds of millions of years. Photosynthesis produces the food, much of the energy (past photosynthesis), and a vast number of materials we depend upon for our survival and comfort. The reactions begin when pigment molecules, acting as an antenna, absorb incident photons, and transfer the excitation energy over the array. The onset of photochemistry occurs when the excitation energy is trapped at a reaction center resulting in the initial charge separation. In plants and cyanobacteria, this light-driven oxidation-reduction occurs in two distinguishable reaction

centers that interact in series. One of these photosystems (PSII) is involved in the oxidation of H_2O and consequent evolution of oxygen. The other PS (I) provides the charge separation that eventually results in the reduction of $NADP^+$. In addition to this linear electron transport, at least under certain conditions, there is a cyclic flow of electrons around PSI, as well as an electrogenic loop between the two photosystems. The components that mediate these light-driven reactions are for the most part located in highly complex membranes, the thylakoids, that resist ion translocation. The transfer of electrons from H_2O to $NADP^+$ is coupled to the accumulation of protons. The energy stored in the proton concentration difference, together with that stored in an electric field due to separation of protons and electrons across the membrane, is used by the coupling factor enzyme to synthesize ATP. The photosynthetic bacteria differ in that they do not evolve oxygen and there is but one photosystem. In green photosynthetic bacteria, the light reaction can drive linear electron transport from a donor (other than H_2O) to NAD^+ . In the purple and brown bacteria, light drives cyclic electron transport that results in a transmembrane electric potential and a transmembrane proton concentration difference. The stored energy is used to synthesize ATP, again by the coupling factor enzyme. Subsequent reverse electron flow, driven by ATP, transfers electrons from a hydrogen donor (e.g., H_2S) to NAD^+ . This volume is concerned with elucidating these aspects of photosynthesis, especially the extent to which the above general statements are applicable, and the modifications, additions, and new concepts that must be considered in order to have a complete molecular understanding. Carbon fixation, photorespiration, and other aspects of plant biology pertaining to photosynthesis (e.g., molecular biology, biosynthesis of membranes, translocation of photosynthates, effects of environment, and plant productivity) are discussed in the Volume II (Govindjee, 1982).

I. Introduction

Photosynthesis is the process by which plants, cyanobacteria, and photosynthetic bacteria convert radiant energy into a chemically stable form. The pathways of energy in the course of this energy transduction are complex, involving many components and several physical and chemical mechanisms. The process is initiated when light is absorbed by an antenna molecule within the photosynthetic membrane. The absorbed energy is transferred over the array; its fate is determined by whether it is trapped at a reaction center and used to do chemically useful work or whether it is emitted as a photon or lost as heat. Although several different pigments are involved in the light-gathering process, the fundamental importance of chlorophyll (Chl) or bacteriochlorophyll (BChl) is clear from the fact that this molecule is common to all photosynthetic antenna systems, as well as reaction centers (RC). Most if not all of the Chl is bound to protein and exhibits different electronic behavior in the membrane than *in vitro*. In this volume the nature of the Chl excited states is discussed by Shipman (Chapter 6, this volume), and the transfer of

excitation energy over the light-gathering molecules is discussed by Pearlstein (Chapter 7, this volume). In the past, it was thought that there was one chemical form of Chl *a* in plants. Recent developments indicating that there are other chemical forms of this ubiquitous molecule are discussed by Rebeiz and Lascelles (Chapter 15, this volume).

Following the absorption of light the initial photochemistry occurs at RC complexes, where the excitation energy is trapped and drives the transfer of an electron from a high potential primary donor [Chl or BChl] to a low potential electron acceptor. This electrochemical energy, stored in the initial charge separation, is used to drive all subsequent electron and proton transfer reactions in photosynthesis. After this time it is no longer meaningful to consider the initially absorbed photon energy as localized; the energy becomes divided into several different forms. The constraints of achieving high efficiency and high rates in this process are substantial as indicated by the complexity of RCs. The structure and function of RCs are discussed by Okamura, Feher, and Nelson (Chapter 5, this volume). The nature of the primary charge separation and of the early donors and acceptors is discussed by Parson and Ke (Chapter 8, this volume).

The RC complexes, the light-harvesting pigments, many of the electron and proton carriers, as well as other proteins (e.g., kinase), are constrained within or on a highly complex membrane. This membrane is relatively resistant to proton movement and forms a closed vesicle, so that there is an inner and outer aqueous phase. The structure and function of these membranes are discussed by Kaplan and Arntzen (Chapter 3, this volume). What is known about the orientation of components and complexes within the membrane is described by Breton and Vermeiglio (Chapter 4, this volume).

Unique to plants and cyanobacteria is their ability to oxidize water and release molecular oxygen. They differ from the photosynthetic bacteria in that they have two distinguishable RCs rather than one. The two RCs of PSI and PSII are connected in series by electron and hydrogen-carrying components. Photosystem I uses the absorbed energy to transfer an electron to a low potential acceptor that via intermediates reduces NADP⁺. Photosystem II contains the RC and components that oxidize water, releasing molecular oxygen, protons, and electrons that reduce the PSI RCs. The steps involved in oxygen evolution and the release of water protons are discussed by Wrydzynski (Chapter 10, this volume). Contributions to this understanding from measurements of thermoluminescence are described by Inoue and Shibata (Chapter 11, this volume).

In plants, cyanobacteria, and photosynthetic bacteria, the light-driven transfer of electrons involves Chl (BChl), pheophytin (bacteriopheophytin), quinones, cytochromes (Cyt) *c* and *b*, FeS centers, plastocyanin, and other electron and hydrogen carriers. In addition to the linear transport in plants and cyanobacteria, there is under some conditions cyclic transport around PSI. Evidence is now available suggesting an electrogenic loop between the two photosystems and in photosynthetic bacteria. Coupled to this multifarious electron transport is proton translocation. The numerous electron and hydrogen carriers and the variety of transport pathways, loops, and cycles are discussed by Cramer and Crofts (Chapter 9, this volume).

A portion of the energy initially stored in the primary charge separation goes into producing a pH gradient via electron transfer-driven proton translocation. In addition, energy is stored in an electric field as a consequence of the separation of electrons and protons across the membrane. Further contributions to the electric potential energy may come from cyclic electron transport around PSI and from an electrogenic "Q-cycle." These two forms of stored energy—electrical potential energy and the proton gradient—combine together to drive the phosphorylation of ADP by the coupling factor protein. Details of the membrane potential are discussed by Junge and Jackson (Chapter 13, this volume), the process and energetics of ATP synthesis by Ort and Melandri (Chapter 12, this volume), and the structure and function of the reversible ATPase enzyme by McCarty and Carmeli (Chapter 14, this volume).

The intent in this volume is to present a conceptual, integrated explanation of plant and bacterial photosynthesis. This comparative approach is especially evident in the following chapter in which Wright discusses current attitudes in photosynthesis starting from van Niel's observations on bacterial and plant photosynthesis in the early 1930s.

II. Basic Concepts from Earlier Work

In the following chapters, the reader is assumed to be familiar with a number of concepts concerning photosynthesis that have been introduced and modified over the last 50 years. Together they provide the basis for the current description of photosynthesis. In this section, the salient features of several of these ideas are briefly sketched and referenced. A notable omission is a discussion of van Niel's contributions, which are detailed in the next chapter.

A. Photosynthetic Unit and Two Light Reactions

In the early 1930s, Emerson and Arnold (1932a) measured O_2 evolution by *Chlorella* using short flashes of light. They inferred from their data that photosynthesis involves a rapid light reaction that is temperature-independent over physiological ranges, followed by a temperature-dependent dark reaction faster than about 20 msec at 25°C. They then went on to ask a simple question that has had a strong influence on subsequent photosynthesis research: If one uses a single, short flash of light to drive photosynthesis, how many CO_2 molecules are reduced per chlorophyll molecule? The experiment depended upon producing light flashes that were intense enough to saturate the photochemistry yet short enough to avoid turning over the reaction more than once. After summing thousands of flashes, they determined that, on the average, a maximum of one O_2 molecule could be evolved per 2480 Chl molecules per flash (Emerson and Arnold, 1932b). From these early experiments emerged the concept of the *photosynthetic unit*, a group of Chl molecules capable of acting cooperatively to reduce one molecule of CO_2 . Originally, the concept of a photosynthetic unit was necessarily vague and, as a consequence, flexible. The nature of the cooperativity and the site and components involved in the photochemistry were not known. In trying to explain the cooperativity of a large number of molecules in a photochemical reaction, Gaffron and Wohl (1936a,b) suggested that absorbed quanta are transferred between Chl molecules until they can be trapped and the energy used to drive a photochemical reaction. [The accompanying volume (see Govindjee, Vol. II, 1982) is dedicated to the memory of H. Gaffron.] Years later, experimental demonstration of energy transfer between different pigments was provided by fluorescence studies in which energy absorbed by one type of pigment sensitized fluorescence from a spectrally distinct pigment, Chl *a* (Dutton *et al.*, 1943; Duysens, 1952; French and Young, 1952). Energy transfer between the Chl *a* molecules was established by measurements showing depolarization of the Chl fluorescence (Arnold and Meek, 1956; Goedheer, 1957; Mar and Govindjee, 1972; Whitmarsh and Levine, 1974; Wong and Govindjee, 1981).

The next major development in the concept of the photosynthetic unit was the characterization of the energy trap or RC in photosynthetic bacteria by Duysens (1952; also see Duysens *et al.*, 1956). He observed that illumination of bacteria led to a decrease in absorbance that he attributed to a bleaching of a small fraction of the BChl. He envisioned a special BChl trapping excitation energy from the antenna pigments and

the energy driving a charge separation reaction. Bessel Kok (to whom this volume is dedicated) observed a similar bleaching in plants near 700 nm that was attributed to a special chlorophyll *a* (P700), the plant reaction center (Kok, 1956, 1957, 1961). These observations made possible a fairly clear picture of the early events in photosynthesis: absorption of a photon by the antenna complex, transfer of excitation energy over the array, trapping of the energy at a special RC complex, where the energy is used to transfer an electron from the RC Chl to the primary acceptor.

A major breakthrough in the study of RCs was their biochemical isolation in photosynthetic bacteria by Reed and Clayton (1968). This opened the search for the mechanisms and components involved in the trapping of energy, primary charge separation, and stabilization by the early donors and acceptors. A search that has now reached into the picosecond time domain (Kaufmann *et al.*, 1975; Rockley *et al.*, 1975).

In the late 1950s, it became evident that two distinguishable light reactions were involved in plants. The experiments of Emerson and co-workers (Emerson, 1957, 1958; Emerson *et al.*, 1957; Emerson and Rabinowitch, 1960) showed that at low light intensities the rate of photosynthesis in combined far-red and shorter wavelength light was greater than the sum of the rates driven by the beams separately (Emerson enhancement effect). Emerson assumed that one reaction was sensitized by auxiliary pigments (e.g. Chl *b*) and the other by Chl *a*. This assumption was incompatible with Duysens' (1952) conclusion that 100% of the energy absorbed by Chl *b* is transferred to Chl *a*. The discovery of bands due to short wavelength forms of Chl *a* and accessory pigments in the action spectra of the Emerson enhancement effect resolved this problem (Govindjee and Rabinowitch, 1960; French *et al.*, 1960): one reaction was sensitized by a short wavelength form of Chl *a* and the other by pigments including a long wavelength form of Chl *a*.

B. Kok and A. Jagendorf wrote in 1963: "Every so often someone manages to remove another stone from the wall through which we all want to see, and the crowds tend to flock around the new peep hole [p. ix]." This was the case with Emerson's discovery. Kautsky *et al.* (1960) also suggested the existence of two light reactions to explain Chl *a* fluorescence changes with time of illumination (Kautsky effect). The relation of Chl *a* fluorescence to the two photosystems was clarified when it was shown that far-red light quenched the high level of fluorescence excited by short wavelength light (Govindjee *et al.*, 1960; Butler, 1962; Duysens and Sweers, 1963). Hill and Bendall (1960) proposed that the two light reactions operate in series. This proposal, now known as the Z scheme, accounted for a number of observations and has now gained general acceptance in the field of photosynthesis. The two photosystems are

named I and II. PSII is the site of H_2O oxidation and results in the reduction of plastoquinone, whereas PSI oxidizes plastoquinol and reduces $NADP^+$. These reactions involve a series of electron and hydrogen carriers. Crucial experiments contributing to the early acceptance of this scheme include those of Duysens *et al.* (1961) showing the antagonistic effect of PSI and PSII on the Cyt *f* redox state; Kok (1959) and Kok and Gott (1960) showing the opposite effect of PSI and PSII light on the redox state of P700; Boardman and Anderson's (1964) biochemical separation of the two photosystems; and the studies of Levine and co-workers (see Levine, 1969) demonstrating the inhibition of electron transport in mutants lacking various electron carriers.

With the introduction of the Z scheme and the observation that O_2 evolution involves a four-step process within a single photosystem (i.e., PSII does not act cooperatively to evolve oxygen; see later), the concept of a photosynthetic unit could be defined as approximately 600 Chl molecules including PSII and PSI and an electron transport chain that could independently evolve oxygen and reduce $NADP^+$. Thus, it was inferred that 300 Chl molecules per RCII or RCI is the minimum unit size for one photosystem. This number was obtained by dividing 2400 by 8 (the minimum quantum number of O_2 evolution; see Emerson, 1958). Although it was shown that the chains could exchange electrons at the level of plastoquinone, the visualization of a photosynthetic unit was often overly rigid (see Myers, 1974). Recently two experimental results may force yet another modification of our description of a photosynthetic unit. First, Melis and Brown (1980) argued that the ratio of PSII to PSI varies considerably depending upon the organism and growth conditions. And second, evidence is accumulating that the grana stacks of thylakoid membranes are enriched in PSII and the stroma and edge regions of grana contain PSI (Andersson and Anderson, 1980). These latter studies raise questions concerning the mobility of large protein complexes within the membrane as well as the problem of long distance electron transport between the two photosystems. It would seem that the original photosynthetic unit concept is too simple to accommodate the complex interactions between the two photosystems that are presently being suggested.

In reading this volume, one may get the impression that there is unanimous agreement concerning the current general description of the light reactions in photosynthesis. However, Arnon and co-workers (1981) recently attacked the very premise of the Hill-Bendall Z scheme. Arnon and co-workers propose that PSII oxidizes H_2O and reduces $NADP^+$ in a two quanta reaction. In this scheme PSI is concerned only with cyclic electron flow. In general, it appears to us that Arnon and co-

workers have attempted to explain their results in terms of a radically new scheme before thoroughly searching for more modest explanations of their data. It is difficult to explain in their scheme (also see Arnold, 1976) the existence of the Emerson enhancement effect in NADP⁺ reduction (R. Govindjee *et al.*, 1962, 1964; Joliot *et al.*, 1968; Avron and Ben-Hayyim, 1969; McSwain and Arnon, 1972) and the antagonistic effect of PSI and PSII light on P700 (Kok and Gott, 1960) and Cyt *f* (Duysens *et al.*, 1961), among several other established observations.

B. Oxygen Evolution

A cursory examination of the equation for the oxidation of H₂O ($2\text{H}_2\text{O} \rightarrow \text{O}_2 + 4\text{H}^+ + 4e^-$) suggests the involvement of four steps in the evolution of oxygen. In experiments that were somewhat similar in design to those of Emerson and Arnold (1932b) and Allen and Franck (1955), Joliot *et al.* (1969) measured the relative amount of O₂ evolved in a short flash in dark-adapted cells of *Chlorella* and chloroplasts as a function of flash number. These influential experiments depended upon a rapid, sensitive polarographic method to detect oxygen (Joliot and Joliot, 1968). Joliot *et al.* found that the oxygen yield exhibited a periodicity of 4 that became damped out as the flash number became large. Shortly thereafter Kok *et al.* (1970) provided the simplest scheme to account for the periodicity and its damping. In this scheme, one PSII RC interacts with a single oxygen-evolving site. Each photochemical reaction, driven by a single photon, results in providing oxidizing equivalents that are accumulated at the oxygen-evolving site. Upon accumulation of four oxidizing equivalents, O₂ is evolved and the site returns to its lowest oxidation state. In this model, there is no exchange of equivalents between different oxygen-evolving sites i.e., they are independent with respect to oxygen evolution (reviewed by Joliot and Kok, 1975).

The components involved in the oxygen-evolving site and their interaction with the RC are still largely unknown. The importance of Mn has been demonstrated in a number of separate studies (e.g., Cheniae, 1970; Blankenship and Sauer, 1974; Yamashita and Tomita, 1974). A dynamic function of Mn was first suggested by NMR and ESR studies of Wydrzynski and co-workers (1976; Govindjee *et al.*, 1977; Wydrzynski and Sauer, 1980).

Recent experiments by Dismukes and co-workers (see, e.g., 1982) on low temperature ESR spectra of Mn in thylakoid membranes, following exposure to a series of single turnover light flashes at room temperature, have provided the most direct evidence for the dynamic function of Mn during O₂ evolution.

Measurements of proton release from PSII as a function of flash number revealed that an oxygen-evolving enzyme does not actually accumulate four oxidizing equivalents releasing O_2 and four protons in one step. There is general agreement that protons are released at least as early as the second flash (Fowler, 1977; Junge *et al.*, 1977; Saphon and Crofts, 1977; also see Förster *et al.*, 1981).

The early experiments of Ruben *et al.* (1941) provided experimental evidence for van Neil's argument that H_2O was the source of O_2 in photosynthesis. This concept has been challenged by Warburg (1964), Metzner (1975), and by Stemler (1980). Although there is general agreement that the ultimate source of O_2 is H_2O (Metzner, 1966; Stemler and Radmer, 1975; Radmer and Ollinger, 1980), Metzner *et al.* (1979) and Stemler (1980) believe that the immediate source of oxygen may be HCO_3^- or CO_2 . The involvement of CO_2 in water oxidation is presently unsettled, although it has been shown that CO_2 plays a role in electron transport between the two photosystems (see review by Vermaas and Govindjee, 1981).

C. Photophosphorylation

Light-driven phosphorylation was first demonstrated in chromatophores from photosynthetic bacteria by Frenkel (1954) and in chloroplasts by Arnon *et al.* (1954). The mechanism by which energy-transducing membranes couple electron flow to ATP synthesis has fascinated researchers to this day. Although the process is complex, tied to charge transfer in ways that only recently have been revealed (e.g. Q cycle), it was in the early 1960s that Mitchell (1961, 1966) offered a conceptually simple and profoundly influential hypothesis to explain the coupling of electron transport to phosphorylation. For this work he received the Nobel prize in 1978. He suggested that electrons transfer results in the vectorial translocation of protons across a membrane; the resulting proton chemical gradient then provides the energy for the phosphorylation of ADP. Not long after this, attention was focused on his proposal by the experiments of Jagendorf and co-workers in which they showed chloroplasts could exhibit light-induced pH changes (Jagendorf and Hind, 1963) and an acid-base jump synthesis of ATP (Jagendorf and Uribe, 1966). These and other contributions are covered extensively in this volume (see Chapters 12–14).

D. Light Emission

A fraction of the radiant energy absorbed by photosynthetic organisms is emitted as light. The features of the emitted radiation are deter-

mined in part by the absorbing pigments, the excitation energy transfer, the fluorescing pigments, and the orientation of these pigments. In addition, the fluorescence is sensitive to a wide variety of photosynthetic events. These include the redox state of the reaction center, donors, and acceptors of PSII, proton translocation, thylakoid stacking and unstacking, ionic strength, and the midpoint potential of Cyt *b*-559, to name a few. Although the dependence of the fluorescence upon these phenomena is often indirect and difficult to quantitate and separate from one another, fluorescence measurements have been used to monitor and characterize a wide variety of events and components. One of its main attractions is that it offers a nondestructive means of probing various photosynthetic reactions (Papageorgiou, 1975; Bufler, 1977; Lavorel and Etienne, 1977). As an example, one of the most fruitful uses of fluorescence has been to establish the existence and measure the midpoint potential of PSII electron acceptors by monitoring the fluorescence intensity as a function of the ambient redox potential (see, e.g., Cramer and Butler, 1969; Golbeck and Kok, 1978; Horton and Croze, 1979; Klimov *et al.*, 1980).

Delayed fluorescence (delayed light emission, luminescence) and thermoluminescence were first observed by Strehler and Arnold (1951) and by Arnold and Sherwood (1957), respectively. Delayed fluorescence is due to a back reaction in which the initial charge separation recombines at the RC providing the energy for the emission of a photon. Thermoluminescence is delayed fluorescence observed during the slow heating of a sample or after a sudden temperature jump (Mar and Govindjee, 1971). Both of these processes have been used to investigate components involved in the early events in the primary charge separation (Lavorel, 1975; Malkin, 1977; Govindjee and Jursinic, 1979; Inoue and Shibita, Chapter 11, this volume).

E. Carbon Fixation and Photorespiration

This volume is concerned with the bioenergetics of what are primarily membrane-bound events commonly known as the light reactions in photosynthesis. These reactions provide the energy, via ATP and reduced NADP, for the reduction of CO₂. The pathway of carbon in photosynthesis was traced by Calvin and co-workers (Bascham *et al.*, 1954). Calvin received a Nobel prize for these studies in 1961. A major development in carbon fixation was the discovery by Kortschak *et al.* (1965) that sugarcane plants fixed carbon initially into a C₄ rather than a C₃ acid. This was followed by a delineation of the detailed pathways in many

plants, now known as C_4 plants, by Hatch and Slack (1966). Another significant discovery in this field relating to photorespiration was the observation that ribulosebiphosphate carboxylase is also an oxygenase (Ogren and Bowes, 1971). These and other topics relating to productivity and efficiency are discussed in the Volume II in this series (Govindjee, 1982).

III. Concluding Remarks

The study of the light-driven reactions in photosynthesis depends on a variety of techniques and approaches involving a wide spectrum of scientific disciplines. The primary aim of the research has been to characterize photosynthetic processes at a molecular level. Currently, as our description of photosynthesis becomes more detailed in terms of basic physicochemical principles, attention is being focused on the relationship between photosynthesis and plant productivity and on the possibility of altering or modifying photosynthetic reactions or applying principles learned from these reactions to develop a practical system of solar energy conversion. For example, can light-driven reduction of protons produce H_2 on a scale that is practical (Rao and Hall, 1977)? Can improving photosynthesis significantly increase productivity (Good and Bell, 1980; Hesketh *et al.*, Chapter 11, in Govindjee 1982)? Emphasis is placed upon producing biomass from nonedible plants, especially on marginal lands (Rolfe and White, 1979). Attempts are also being made to grow plants that produce petroleum-like substances (Calvin, 1977).

IV. Literature

The present volume is an expansion of the book edited by Govindjee (1975) in this series. The unique feature of this volume is the integration of plant and bacterial work. Several topics (fluorescence, delayed fluorescence, pigment-protein complexes, and ion transport) that were covered previously are not thoroughly covered here. The topics of CO_2 fixation and plant productivity, not covered at all in the earlier book, now appear in a separate volume (Govindjee, 1982).

Several symposia volumes, edited books, special journal issues, and single authored books have appeared since 1975. (For earlier reviews, see Govindjee, 1975.) Some of these are listed below. Symposia volumes include the proceedings of the three International Congresses on Photo-

synthesis Research edited by Avron (1975), Hall *et al.* (1978) and Akoyunoglou (1981); other more specialized conference proceedings are those edited by Olson and Hind (1977) on protein complexes; Packer *et al.* (1977) on bioenergetics of membranes; Akoyunoglou and Argyroudi-Akoyunoglou (1978) on chloroplast development; Metzner (1978) on O₂ evolution; Chance *et al.* (1979) on electron tunneling, and Trumppower (1981) on quinones. Multiauthor books on various aspects of photosynthesis are those edited by Barber (1976) on intact chloroplasts; Barber (1977) on primary processes; Trebst and Avron (1977) on electron transport and photophosphorylation; Clayton and Sistrom (1978) on photosynthetic bacteria; Barber (1979) on model systems; Hatch and Boardman (1981) on several aspects of photosynthesis; Alfano (1982) on ultrafast laser spectroscopy; and Barber (1982) on electron transport and photophosphorylation. A special issue on ultrafast reactions in photosynthesis was edited by Govindjee (1978). Other books are those edited by Burris and Black (1976) on CO₂ metabolism and plant productivity, San Pietro (1980a) on energy production, and San Pietro (1980b) on methods in photosynthesis. An excellent single-authored book on photosynthesis is that by Clayton (1980).

For an up-to-date knowledge, the reader should consult the recent issues of various journals including: *Annual Review of Plant Physiology*, *Archives of Biochemistry and Biophysics*, *Biochemical and Biophysical Research Communications*, *Biochemistry*, *Biochimica et Biophysica Acta (Bioenergetics)*, *Biokhimiya*, *Biofizika*, *Biophysical Journal*, *Doklady Akademy Nauk SSSR*, *FEBS Letters*, *Journal of Biological Chemistry*, *Journal of Theoretical Biology*, *Photobiochemistry and Photobiophysics*, *Photochemistry and Photobiology*, *Photosynthesis Research*, *Photosynthetica*, *Physiologia Plantarum*, *Plant and Cell Physiology*, *Plant Physiology*, *Plant Science Letters*, *Proceedings of the National Academy of Sciences, U.S.A.*, and *Zeitschrift für Naturforschung*.

REFERENCES

- Akoyunoglou, G., ed. (1981). "Photosynthesis," Proceedings of the Fifth International Congress on Photosynthesis, 6 vols. Balaban International Science Service Press, Philadelphia, Pennsylvania.
- Akoyunoglou, G., and Argyroudi-Akoyunoglou, G., eds. (1978). "Chloroplast Development," Elsevier/North-Holland Biomedical Press, Amsterdam.
- Alfano, R. R., ed. (1982). "Biological Events Probed by Ultrafast Laser Spectroscopy." Academic Press, New York.
- Allen, F. L., and Franck, J. (1955). *Arch. Biochem. Biophys.* **58**, 124-143.
- Andersson, B., and Anderson, J. M. (1980). *Biochim Biophys. Acta* **593**, 427-440.
- Arnold, W. (1976). *Proc. Natl. Acad. Sci. U.S.A.* **73**, 4402-4405.
- Arnold, W., and Meek, E. S. (1956). *Arch. Biochem. Biophys.* **60**, 82-80.

- Arnold, W., and Sherwood, H. K. (1957). *Proc. Natl. Acad. Sci. U.S.A.* **43**, 105-114.
- Arnon, D. I., Whately, F. R., and Allen, M. B. (1954). *J. Am. Chem. Soc.* **76**, 6324-6329.
- Arnon, D. I., Tsujimoto, H. Y., and Tang, G. M.-S. (1981). *Proc. Natl. Acad. Sci. U.S.A.* **78**, 2942-2946.
- Avron, M., ed. (1975). "Proceedings of the Third International Congress on Photosynthesis," 3 vols. Elsevier, Amsterdam.
- Barber, J., ed. (1976). "The Intact Chloroplast." Elsevier, Amsterdam.
- Barber, J., ed. (1977). "Primary Processes of Photosynthesis." Elsevier, Amsterdam.
- Barber, J., ed. (1979). "Photosynthesis in Relation to Model Systems." Elsevier, Amsterdam.
- Barber, J., ed. (1982). "Electron Transport and Photophosphorylation." Elsevier, Amsterdam.
- Bassham, J. A., Benson, A. A., Kay, L. D., Harris, A. Z., Wilson, A. T., and Calvin, M. (1954). *J. Am. Chem. Soc.* **76**, 1760-1770.
- Blankenship, R. E., and Sauer, K. (1974). *Biochim. Biophys. Acta* **357**, 252-266.
- Boardman, N. K., and Anderson, J. (1964). *Nature (London)* **203**, 166-170.
- Burris, H. R., and Black, C. C., eds. (1976). "CO₂ Metabolism and Plant Productivity." University Park Press, Baltimore, Maryland.
- Butler, W. L. (1962). *Biochim. Biophys. Acta* **64**, 309-317.
- Butler, W. L. (1977). In "Photosynthesis I" (A. Trebst and M. Avron, eds.), pp. 149-186. Springer-Verlag, Berlin and New York.
- Calvin, M. (1977). *Energy Res.* **1**, 299-327.
- Chance, B., DeVault, D., Fraunfelder, H., Marcus, R. A., Schrieffer, J. R., and Sutin, N., eds. (1979). "Tunneling in Biological Systems." Academic Press, New York.
- Chenai, G. (1970). *Annu. Rev. Pl. Physiol.* **21**, 467-498.
- Clayton, R. K. (1980). "Photosynthesis: Physical Mechanisms and Chemical Patterns." Cambridge Univ. Press, Cambridge, Mass.
- Clayton, R. K., and Sistrom, W. R., eds. (1978). "The Photosynthetic Bacteria." Plenum, New York.
- Cramer, W., and Butler, W. L. (1969). *Biochim. Biophys. Acta* **172**, 503-510.
- Dismukes, G. C., Ferris, K., and Watnick, P. (1982). *Photobiochem. Photobiophys.* **3**, 243-256.
- Dutton, H. J., Manning, W. M., and Duggar, B. B. (1943). *J. Phys. Chem.* **47**, 308-313.
- Duysens, L. N. M. (1952). Ph.D. Thesis, The State University, Utrecht, The Netherlands.
- Duysens, L. N. M., and Sweers, H. E. (1963). In "Studies in Microalgae and Photosynthetic Bacteria" (J. Ashida, ed.), pp. 353-372. Univ. of Tokyo Press, Tokyo.
- Duysens, L. N. M., Huiskamp, W. J., Vos, J. J., and van der Hart, J. M. (1956). *Biochim. Biophys. Acta* **19**, 188-190.
- Duysens, L. N. M., Ames, J., and Kamp, B. M. (1961). *Nature (London)* **190**, 510-511.
- Emerson, R. (1957). *Science* **125**, 746.
- Emerson, R. (1958). *Annu. Rev. Plant Physiol.* **9**, 1-24.
- Emerson, R., and Arnold, W. (1932a). *J. Gen. Physiol.* **15**, 391-420.
- Emerson, R., and Arnold, W. (1932b). *J. Gen. Physiol.* **16**, 191-205.
- Emerson, R., and Rabinowitch, E. (1960). *Plant Physiol.* **35**, 477-485.
- Emerson, R., Chalmers, R. V., and Cederstrand, C. (1957). *Proc. Natl. Acad. Sci. U.S.A.* **43**, 133-143.
- Förster, V., Hong, Y.-Q., and Junge, W. (1981). *Biochim. Biophys. Acta* **638**, 141-152.
- Fowler, C. F. (1977). *Biochim. Biophys. Acta* **462**, 414-421.
- French, C. S., and Young, V. M. K. (1952). *J. Gen. Physiol.* **35**, 873-890.
- French, C. S., Myers, J., and Macleod, G. (1960). In "Comparative Biochemistry of Photoactive Systems" (M. B. Allen, ed.), Vol. 1, pp. 361-365. Academic Press, New York.

- Frenkel, A. W. (1954). *J. Am. Chem. Soc.* **76**, 5568–5569.
- Gaffron, H., and Wohl, K. (1936a). *Naturwissenschaften* **24**, 81–90.
- Gaffron, H., and Wohl, K. (1936b). *Naturwissenschaften* **24**, 103–107.
- Goedheer, J. H. C. (1957). Ph. D. Thesis, The State University, Utrecht, The Netherlands.
- Golbeck, J. H., and Kok, B. (1978). *Biochim. Biophys. Acta* **547**, 347–360.
- Good, N., and Bell, D. (1980). In "Photosynthetic Plant Production and Crop Yield" (P. Carlson, ed.), pp. 3–51. Academic Press, New York.
- Govindjee, ed. (1975). "Bioenergetics of Photosynthesis." Academic Press, New York.
- Govindjee, ed. (1978). "Ultrafast Reactions in Photosynthesis," Special Issue of Photochemistry and Photobiology, **28**, pp. 935–1035. Pergamon, Oxford.
- Govindjee, ed. (1982). "Photosynthesis: Development Carbon Metabolism and Plant Productivity," Vol. II. Academic Press, New York.
- Govindjee, and Jursinic, P. (1979). *Photochem. Photobiol. Rev.* **4**, 125–205.
- Govindjee, and Rabinowitch, E. (1960). *Science* **132**, 355–356.
- Govindjee, Ichimura, S., Cederstrand, C., and Rabinowitch, E. (1960). *Arch. Biochem. Biophys.* **89**, 322–323.
- Govindjee, Wydrzynski, T., and Marks, S. B. (1977). In "Bioenergetics of Membranes" (L. Packer, G. C. Papageorgiou, and A. Trebst, eds.), pp. 305–316. Elsevier/North-Holland, Amsterdam.
- Govindjee, R., Govindjee, and Hoch, G. (1962). *Biochem. Biophys. Res. Commun.* **9**, 222–225.
- Govindjee, R., Govindjee, and Hoch, G. (1964). *Plant Physiol.* **39**, 10–14.
- Hall, D. O., Coombs, J., and Goodwin, T. W., eds. (1978). "Photosynthesis '77," Proceedings of the Fourth International Congress on Photosynthesis. Biochem. Soc., London.
- Hatch, M. D., and Boardman, N. K., eds. (1981). "Photosynthesis, The Biochemistry of Plants," Vol. 8. Academic Press, New York.
- Hatch, M. D., and Slack, M. R. (1966). *Biochem. J.* **101**, 103–111.
- Hill, R., and Bendall, F. (1960). *Nature (London)* **186**, 136–137.
- Horton, P., and Croze, E. (1979). *Biochim. Biophys. Acta* **545**, 188–201.
- Jagendorf, A., and Hind, G. (1963). *N.A.S.—N.R.C., Publ.* **1145**, 599–610.
- Jagendorf, A., and Uribe, E. (1966). *Proc. Natl. Acad. Sci. U.S.A.* **55**, 170–177.
- Joliot, P., and Joliot, A. (1968). *Biochim. Biophys. Acta* **153**, 625–634.
- Joliot, P., and Kok, B. (1975). In "Bioenergetics of Photosynthesis" (Govindjee, ed.), pp. 387–412. Academic Press, New York.
- Joliot, P., Joliot, A., and Kok, B. (1968). *Biochim. Biophys. Acta* **153**, 635–652.
- Joliot, P., Barbieri, G., and Chabaud, R. (1969). *Photochem. Photobiol.* **10**, 309–329.
- Junge, W., Renger, G., and Ausländer, W. (1977). *FEBS Lett.* **79**, 155–159.
- Kaufmann, K. J., Dutton, P. L., Netzel, T. L., Leigh, J. S., and Rentzepis, P. M. (1975). *Science* **188**, 1301–1304.
- Kautsky, H., Appel, W., and Amann, H. (1960). *Biochem. Z.* **332**, 277–290.
- Klimov, V. V., Allakhverdiev, S. I., Demeter, S., and Krasnovsky, A. A. (1980). *Dokl. Akad. Nauk. SSSR* **249**, 227–230.
- Kok, B. (1956). *Biochim. Biophys. Acta* **22**, 399–401.
- Kok, B. (1957). *Acta Bot. Neerl.* **6**, 316–336.
- Kok, B. (1959). *Plant Physiol.* **34**, 184–192.
- Kok, B. (1961). *Biochim. Biophys. Acta* **48**, 527–533.
- Kok, B., and Gott, W. (1960). *Plant Physiol.* **35**, 802–808.
- Kok, B., and Jagendorf, A. T., eds. (1963). "Photosynthetic Mechanisms of Green Plants," Publ. No. 1145. Nat. Acad. Sci.—Nat. Res. Council, Washington, D.C.
- Kok, B., Forbush, B., and McGloin, M. (1970). *Photochem. Photobiol.* **11**, 457–475.
- Kortschak, H. P., Hartt, C. E., and Burr, G. D. (1965). *Plant Physiol.* **40**, 209–213 (also see *Proc. Hawaii Acad. Sci.*, Vol. 21, 1957).

- Lavorel, J. (1975). In "Bioenergetics of Photosynthesis" (Govindjee, ed.), pp. 223-317. Academic Press, New York.
- Lavorel, J., and Etienne, A. L. (1977). In "Primary Processes of Photosynthesis" (J. Barber, ed.), pp. 203-268. Elsevier, Amsterdam.
- Levine, R. P. (1969). *Annu. Rev. Plant Physiol.* **20**, 523-540.
- McSwain, B. D., and Arnon, D. I. (1972). *Biochem. Biophys. Res. Commun.* **49**, 68-75.
- Malkin, S. (1977). In "Primary Processes of Photosynthesis" (J. Barber, ed.), pp. 349-431. Elsevier, Amsterdam.
- Mar, T., and Govindjee (1971). *Biochim. Biophys. Acta* **226**, 200-203.
- Mar, T., and Govindjee (1972). *Photosynth., Two Centuries After Its Discovery By Joseph Priestley, Res., 2nd, 1971 Proc. Int. Congr. Photosynth., Vol. 1*, pp. 271-281. Dr. W. Junk Publ., The Hague.
- Melis, A., and Brown, J. (1980). *Proc. Natl. Acad. Sci. U.S.A.* **77**, 4712-4716.
- Metzner, H. (1966). *Naturwissenschaften* **53**, 141-150.
- Metzner, H. (1975). *J. Theoret. Biol.* **51**, 201-231.
- Metzner, H., ed. (1978). "Photosynthetic Oxygen Evolution." Academic Press, New York.
- Metzner, H., Fischer, K., and Bazlen, O. (1979). *Biochim. Biophys. Acta* **548**, 287-295.
- Mitchell, P. (1961). *Nature (London)* **191**, 144-148.
- Mitchell, P. (1966). *Biol. Rev. Cambridge Philos. Soc.* **41**, 445-502.
- Myers, J. (1974). *Plant Physiol.* **54**, 420-426.
- Ogren, W. L., and Bowes, G. (1971). *Nature (London), New Biol.* **230**, 159-160.
- Olson, J. M., and Hind, G., eds. (1977). "Chlorophyll Proteins, Reaction Centers, and Photosynthetic Membranes," Brookhaven Symp. Biol. No. 28. Brookhaven Natl. Lab., Upton, New York.
- Packer, L., Papageorgiou, G. C., and Trebst, A., eds. (1977). "Bioenergetics of Membranes." Elsevier/North-Holland Biomedical Press, Amsterdam.
- Papageorgiou, G. (1975). In "Bioenergetics of Photosynthesis" (Govindjee, ed.), pp. 319-371. Academic Press, New York.
- Radmer, R., and Ollinger, O. (1980). *FEBS Lett.* **110**, 57-61.
- Rao, K. K., and Hall, D. O. (1977). In "Photosynthesis in Relation to Model Systems" (J. Barber, ed.), pp. 299-329. Elsevier, Amsterdam.
- Reed, D., and Clayton, R. K. (1968). *Biochem. Biophys. Res. Commun.* **30**, 471-475.
- Rockley, M. C., Windsor, M. W., Cogdell, R. J., and Parson, W. W. (1975). *Proc. Natl. Acad. Sci. U.S.A.* **72**, 2251-2255.
- Rolfe, G. L., and White, T. A. (1979). *Ill. Res.* **21** (2), 1-2.
- Ruben, S., Randall, M., Kamen, M., and Hyde, J. L. (1941). *J. Am. Chem. Soc.* **63**, 877-880.
- San Pietro, A., ed. (1980a). "Biochemical and Photosynthetic Aspects of Energy Production." Academic Press, New York.
- San Pietro, A., ed. (1980b). "Methods in Enzymology," Vol. 69, Part C. Academic Press, New York.
- Saphon, S., and Crofts, A. R. (1977). *Z. Naturforsch., C: Biosci.* **32C**, 617-626.
- Stemler, A. (1980). *Biochim. Biophys. Acta* **593**, 103-112.
- Stemler, A., and Radmer, R. (1975). *Science* **190**, 457-458.
- Strehler, B., and Arnold, W. (1951). *J. Gen. Physiol.* **34**, 809-829.
- Trebst, A., and Avron, M., eds. (1977). "Photosynthesis I: Photosynthetic Electron Transport and Photophosphorylation." Springer-Verlag, Berlin and New York.
- Trumpower, B., ed. (1981). "Function of Quinones in Energy Coupling Systems." Academic Press, New York.
- Vermaas, W. F. J., and Govindjee (1981). *Proc.—Indian Acad. Sci., Biol. Ser. B* **47**, 581-605.
- Warburg, O. (1964). *Annu. Rev. Biochem.* **33**, 1-14.
- Whitmarsh, J., and Levine, R. P. (1974). *Biochim. Biophys. Acta* **368**, 199-213.

- Wong, D., and Govindjee (1981). *Photochem. Photobiol.* **33**, 103-108.
- Wydrzynski, T., and Sauer, K. (1980). *Biochim. Biophys. Acta* **589**, 56-70.
- Wydrzynski, T., Zumbulyadis, N., Schmidt, P. G., Gutowsky, H. S., and Govindjee (1976). *Proc. Natl. Acad. Sci. U.S.A.* **73**, 1196-1198.
- Yamashita, T., and Tomita, G. (1974). *Plant Cell Physiol.* **15**, 69-82.

Current Attitudes in Photosynthesis Research

COLIN A. WRAIGHT

I. Introduction.....	19
II. Reaction Centers.....	21
A. Primary Events.....	21
B. The Acceptor Complexes.....	25
III. Electron Transfer Out of the Reaction Center.....	28
A. Acceptor Reactions.....	28
B. Donor Reactions.....	31
IV. The Electron Transport Chain.....	33
A. Linear and Cyclic Flows.....	33
B. The Cytochrome <i>b-c</i> ₁ and <i>b₆-f</i> Complexes.....	34
C. Lateral Transport of Reducing Equivalents.....	42
V. Energy Transduction.....	44
A. The Proton Motive Force as Intermediate.....	44
B. Stoichiometries of the Coupling Process.....	46
C. The ATPases.....	47
VI. Structure and Organization of the Photosynthetic Apparatus.....	48
A. Molecular Organization.....	48
B. Membrane Structure.....	50
VII. Phylogenetic and Metabolic Comparisons in Photosynthesis.....	51
VIII. Concluding Remarks.....	54
References.....	55

ABBREVIATIONS

<i>A</i> _{1,1} , <i>A</i> _{1,2} , <i>A</i> _{1,3}	Primary, secondary, and tertiary acceptor of PSI (nomenclature described by Parson and Ke, this volume)
ADP, ATP	Adenosine di- and triphosphate
ATP/2 <i>e</i>	Ratio of ATP per pair of electrons transferred
ATPase	ATP-hydrolase that is driven as an ATP-synthase by the free energy of the electron transport redox reactions
B	Secondary acceptor quinone of PSII (also called R)
BChl	Bacteriochlorophyll; also, BChl <i>a</i> , <i>b</i> (<i>c</i> , <i>d</i> and <i>e</i>)
Bph	Bacteriopheophytin
C	A special (bacterio)chlorophyll implicated as a very early, intermediate electron acceptor in the photochemistry of purple bacteria and PSII
Chl	Chlorophyll; also, Chl <i>a</i> , <i>b</i> (<i>c</i> , <i>d</i> , and <i>e</i>)
Cyt	Cytochrome(s)

ΔpH	pH gradient across a membrane
$\Delta\phi$ or pmf	Total protonic potential difference or proton motive force across a membrane; the electrochemical activity gradient of H^+ , $\Delta\mu_{\text{H}^+}$
$\Delta\psi$	Electrical potential difference across a membrane
E_m	Oxidation–reduction (redox) midpoint potential; also, $E_{m,7}$, midpoint potential at pH 7; $E_{m,pK}$, midpoint potential in the pH-independent regions beyond the pK values of the redox couple
ENDOR	Electron-nuclear double resonance
ESR	Electron spin (paramagnetic) resonance
Fe–S	Iron–sulfur center
FNR	Ferredoxin–NADP ⁺ reductase
GC	Total guanosine plus cytosine content of a nucleic acid
H	A special (bacterio)pheophytin active as an electron acceptor in the primary events of photosynthesis in purple bacteria and PSII
H^+/ATP	Mole ratio of H^+ ions translocated per mole of ATP synthesized by H^+ -translocating ATP synthase (ATPase)
H^+/e^-	Ratio of H^+ translocated across the membrane per electron passing through the electron transport chain
I	Composite intermediate electron acceptor in photosynthetic primary events of purple bacteria and PSII; includes both C and H (see above)
MQ	Menaquinone (2-methyl-3-isoprenylnaphthoquinone)
NAD^+/NADH	Nicotinamide adenine dinucleotide (oxidized and reduced forms)
$\text{NADP}^+/\text{NADPH}$	Nicotinamide adenine dinucleotide phosphate (oxidized/reduced forms)
P	The primary electron donor of photosynthetic reaction centers. Also, P680, P700, P840, P870, P960—designations according to the longest wavelength absorption maximum
Ph	Pheophytin (chlorophyll lacking the central magnesium atom)
pI	Isoelectric point: pH at which a particle or protein has zero net charge
PQ	Plastoquinones (2,3-dimethyl-5-isoprenylbenzoquinone)
PSI, PSII	Photosystem I and photosystem II of oxygenic photosynthetic organisms, including cyanobacteria, algae, and higher plants
Q	“Primary” acceptor quinone of PSII; also, quinone in general, especially Q (quinone), QH_2 (quinol), QH protonated semiquinone, Q^- anionic (deprotonated) semiquinone, etc
Q_A , Q_B	Primary and secondary acceptor quinones of purple photosynthetic bacteria (also referred to as Q_I , Q_{II})
RC	Reaction center
RNA	Ribonucleic acid, especially: 16 S rRNA, ribosomal(4) RNA with 16 S sedimentation coefficient
UQ	Ubiquinone 2,3-dimethoxy-5-isoprenyl-6-methylbenzoquinone

Van Niel's hypothesis of the unified nature of bacterial and plant photosynthesis was first published 50 years ago (1931). This chapter presents a comparison of current views of the biophysical chemistry of photosynthesis in bacteria and plants. Striking parallels exist at all levels,

from pigment biosynthesis through primary photochemical events, coupled electron and proton transfer, and ATP synthesis, to regulation of energy coupling and membrane and protein structure. Equally strong parallels are found in all bioenergetic coupling systems, indicating a clear, but poorly understood, evolutionary relationship. The molecular homologies, counterparts to the physiological ones that led van Niel to his proposal, are sufficiently strong that the direct transfer of concepts and information has greatly benefited research on bacterial and plant photosynthesis and on bacterial and mitochondrial respiration. This is likely to continue to be an important function of photosynthesis research at the biophysical level.

I. Introduction

The insights and revelations afforded by comparative studies in physiology and biochemistry have provided some of the most significant advances in biology and it is, perhaps, hard to remember that the validity of comparative studies has not always been universally accepted. Van Niel's unified formulation of bacterial and plant photosynthesis, based on comparative metabolic physiology, was developed at a time when the utility of this approach was still suspect. His achievement, which provided such a potent and fruitful influence on three decades of photosynthesis research, was, therefore, all the more remarkable (van Niel, 1931, 1941). Although little of van Niel's original hypothesis has survived intact into the last decade, even the least generous of modern perspectives must acknowledge just how farsighted was his intuition and how effective was his use of the conservative principles of evolution. Nor was he alone in this. In view of the complexities of the photosynthetic process as we now know it, the vision of the pioneers of this field in the 1930s is astonishing.

Van Niel believed that the stoichiometric parallels in the overall reactions of bacterial and plant photosynthesis reflected a more fundamental and mechanistic kinship. He suggested that the photochemical products of both types were oxidized and reduced entities which were responsible for the subsequent reduction of CO_2 and oxidation of available hydrogen donors in two entirely separate sequences of dark reactions. In plants, the hydrogen donor was water, releasing oxygen, whereas in bacteria a wide variety of organic and inorganic materials (but not water) could suffice. Van Niel's view of biological oxidation-reduction was influenced by Wieland's relatively new concept of dehydrogenation. This led to a natural formalism in which the photochemical act was a photo-

lytic separation of H and OH from water. Depending on its bound state, the OH moiety could be sufficiently oxidizing to yield O_2 from water, requiring a minimum photonic energy corresponding to red light, i.e., oxidized chlorophyll (Chl) or it could be a weaker oxidant, incapable of evolving O_2 and requiring only the near infrared region, i.e., oxidized bacteriochlorophyll (BChl). The primary involvement of water as a chlorophyll–water adduct was specifically suggested by Stöll (1932) on the basis of the known extreme hygroscopy of chlorophyll. In spite of the flimsy experimental basis, this suggestion now seems positively prophetic in the light of recent models of the primary electron donor in bacterial and plant photosynthesis (Katz *et al.*, 1978; Norris and Katz, 1978; see Okamura *et al.*, Chapter 5, and Parson and Ke, Chapter 8, this volume).

The lasting contribution of van Niel's hypothesis was to focus attention on the fundamental nature of the photochemistry. The application of conservative principles to comparative biochemistry allowed him to strip away the veil of dark reactions surrounding the photochemistry and to state unequivocally that "there is no reason for supposing that the photochemical reaction in purple bacteria differs fundamentally from that assumed to occur in green plants [van Niel, 1941, p. 323]." He thereby rejected the notion of a photosensitized "rearrangement" of H_2O and CO_2 on the Chl and instated the more fundamental and experimentally accessible principle of photochemical oxidation–reduction (see also Rabinowitch, 1945).

Although introductory, this chapter does presume some prior knowledge of photosynthesis. There are several excellent introductory texts for the subject. For a predominantly biophysical view, Clayton's most recent book (Clayton, 1981) is exceptionally clear as well as broad-based and very up-to-date. Details of CO_2 fixation are discussed in Volume II, also edited by Govindjee (1982). In order to help orient the reader, schematics of the photosynthetic electron transport systems of bacteria and plants are shown in Fig. 1. This figure will be developed throughout this chapter.

II. Reaction Centers

A. Primary Events

Van Niel's notion of the essential equivalence of the photochemistry of plant and bacterial photosynthesis still holds good today, even as current work reveals glimpses of the actual structure of the photoactive complexes, and kinetic studies push toward the sub-picosecond time

domain (see Okamura *et al.*, Chapter 5, and Parson and Ke, Chapter 8, this volume). In the purple bacterium, *Rhodospseudomonas (Rp.) sphaeroides*, evidence now strongly supports a BChl dimer, or "special pair," structure for the primary electron donor, P870 (Norris and Katz, 1978). (See left panel in Fig. 1.) The most satisfactory models for P870 invoke hydrogen bonding by a water molecule, linking two cofacial BChl monomers (Shipman *et al.*, 1976), an extraordinary echo of Stöll's suggestion of 50 years ago!

Dimeric structures were originally proposed for P700, the primary electron donor of PSI in plants, but ENDOR studies, which fully support the bacterial "special pair," are only weakly supportive of a dimer structure for P700. Recent ESR studies of ^{13}C -enriched material apparently have now ruled out a dimer structure for P700^+ , although fully supporting it for P870^+ (Wasielewski *et al.*, 1981a). This reopens the door for new conceptual approaches to the structure of P700. A recent suggestion is that of a Chl *a* monomer with an enol configuration in ring V. This structure can be stabilized *in vitro* as a silyl ether and has been found to have an appropriately low reduction potential (Wasielewski *et al.*, 1981a,b). ^{13}C studies are now underway in other bacterial species, including *Rp. viridis* and *Chlorobium (Chl.) limicola*. Within the same basic structure, a range of configurations between monomer and symmetrical dimer is conceivable.

Presumptive parallels between the dark electron transport in purple bacteria and that associated with PSI (see right portion of the middle panel of Fig. 1) led to the common belief that these two photosystems would be similar (e.g., Bolton, 1977). This was probably responsible for keeping the dimer picture for P700 alive in spite of the unconvincing ENDOR data. Studies on the nature of the transient photoreduced products have, however, indicated a far more striking analogy between the purple bacteria and PSII (see left portion of the middle panel of Fig. 1) of plants. In both cases, the following sequence of events probably occurs (see Parson and Ke, this volume).

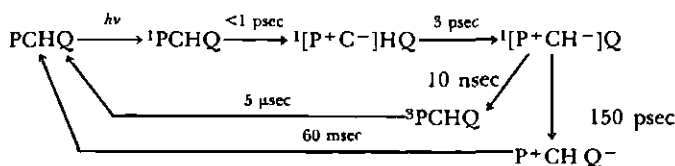

Scheme 1

In bacteria, P is the special pair of BChl (P870), C is a BChl monomer, H is Bph, and Q is ubiquinone. For historical reasons Q, the first compo-

ment to be stably or metastably reduced, is called the "primary" acceptor. Both C and H contribute to the originally observed "intermediate," I, and all three can be usefully but imprecisely termed *intermediate acceptors* (see Parson and Ke, Chapter 8, and Okamura *et al.*, Chapter 5, this volume). An analogous sequence has recently been suggested for PSII, at least as far as the involvement of pheophytin (Ph) (Klimov *et al.*, 1980a; Shuvalov *et al.*, 1980; Rutherford *et al.*, 1981a; Parson and Kee, Chapter 8, this volume). Several illumination regimes under reducing conditions have been used to trap bacterial and PSII reaction centers (RC) in various states of electron accumulation, e.g., PQ^- , PH^-Q^- , PH^-Q^{2-} . Studies by A. W. Rutherford and co-workers have now demonstrated a trapped state in bacteria (*Rp. viridis*) (Rutherford and Thurnauer, unpublished observations) and PSII (Rutherford, 1981) that may be $PC^-H^-Q^{2-}$. This would demonstrate a mechanistic homology between bacteria and PSII even at the level of C, the earliest known intermediate.

If forward electron transfer from H^- to Q is blocked, e.g., by extraction or prior reduction of Q, the charge separation state P^+BH^- can recombine via a triplet state pathway to yield 3P (see Scheme 1), which is readily observable by both optical and magnetic resonance techniques (Dutton *et al.*, 1972; Cogdell *et al.*, 1975; Thurnauer *et al.*, 1975; Hoff, 1976; Prince *et al.*, 1976; van Grondelle *et al.*, 1978; see Parson and Ke, Chapter 8, this volume). These so-called RC triplets (as distinct from antenna pigment triplets) have many unusual properties that reflect both their origin and their localization in the RC. In particular, the unique polarization pattern of all RC triplets (bacterial, PSII, and PSI) demonstrates their formation by a radical pair recombination mechanism (Thurnauer *et al.*, 1975; Thurnauer and Norris, 1977). Furthermore, the magnetic field dependence of the triplet and fluorescence yields confirms that in all cases forward photochemistry is through the singlet state (Blankenship *et al.*, 1977; Hoff *et al.*, 1977; Rademaker *et al.*, 1979; Parson and Ke, Chapter 8, this volume). In bacteria, the RC triplet exhibits a somewhat narrowed magnetic resonance spectrum, which reflects the extended structure of the special pair (Leigh and Dutton, 1974; Thurnauer and Norris, 1977; Norris and Katz, 1978). The more recently observed ESR spectra for PSI and PSII triplets, however, are not narrowed (Frank *et al.*, 1979; Rutherford and Mullet, 1981; Rutherford *et al.*, 1981b). For PSI, this is entirely consistent with the new view of P700 as a monomer. For PSII, it may also suggest that P680 is not a "special pair" (van Gorkom *et al.*, 1974) in spite of the general similarity with bacterial RCs. Unfortunately, no definite conclusion can be drawn from the triplet data, as many factors can conspire to diminish its diag-

nostic value (Levanon and Norris, 1978). It is certainly possible, however, that simple variations in the macrocycle, i.e., Ch versus BChl may be insufficient to account for the markedly different redox properties of P680 (estimated $E_m \approx +1.1$ V; Jursinic and Govindjee, 1977) and P870 ($E_m \approx +0.5$ V). A dimeric structure is considered likely to lower the characteristic potential relative to the monomer (Norris and Katz, 1978; Davis *et al.*, 1979; Wasielewski *et al.*, 1981a,b).

Although a dimeric structure for P700⁺ now seems less likely, significant similarities exist between PSI and PSII and the purple bacterial photosystem. In particular, picosecond studies suggest that the intermediate acceptor ($A_{I,1}$)* for PSI is a Chl *a*, possibly monomeric (Fenton *et al.*, 1979; Shuvalov *et al.*, 1979a,b; see Parson and Ke, Chapter 8, this volume) and chemical analysis does not support an involvement of Ph in PSI (Thornber *et al.*, 1976). It should be mentioned that the most detailed spectra of $A_{I,1}$ have been obtained at longer times when there appears to be some uncertainty in distinguishing the optical difference spectra for formation of the Chl *a* anion and the RC triplet. Identification of a Chl anion intermediate was originally thought to distinguish PSI from PSII and the purple bacteria, where the intermediate was identified as (bacterio) pheophytin (Bph) (Okamura *et al.*, and Parson and Ke, Chapter 8, this volume). However, as described earlier, recent evidence now indicates the very early involvement of a Chl or BChl anion in all photosystems. Regardless of the exact identity, chlorin structures (Chls and Phs) appear to be uniquely active in the earliest charge separation events in all photosynthetic systems. The significance of this fact is obscure at the present time, but a number of plausible rationalizations have been offered (Fajer *et al.*, 1976, 1980; Parson and Ke, Chapter 8, this volume).

Several chemically distinct Chls and Phs are found in different species but the varieties actively involved in photochemistry have appeared limited. Only Chl *a*, BChl *a* and, in a very few cases, BChl *b* have been recognized, so that conservatism of structure has become something of a dogma. The observation of several spectroscopic forms of Chl *a* and *b*, extractable from mature chloroplasts is, therefore, of considerable interest (see Rebeiz and Lascelles, Chapter 15, this volume). The identification of these Chl species as chemically distinct entities, however, is only established for one form, found in large quantities in a mutant of *Zea mays* (Bazzaz and Brereton, 1982; Bazzaz *et al.*, 1982). The existence of

*Roman subscript I denotes that the Acceptor (A) is from PSI and the Arabic subscript 1 following it denotes that it is the first one in the series (also see Parson and Ke, Chapter 8, this volume).

variants in Chl-precursor pools has also been suggested (Bélanger and Rebeiz, 1980; Bazzaz, 1981a,b; Rebeiz and Lascelles, Chapter 15, this volume). If the new spectral forms of Chl do indeed represent distinct, *in vivo* chemical species, their significance is as yet unknown. Recent studies have indicated a heterogeneous distribution between different subchloroplast portions (Bazzaz, 1980; Freyssinet *et al.*, 1980) but the possibility of artifact is considerable and the relative distribution appears to vary with the procedure for particle preparation. In spite of these uncertainties it seems very probable that there is a previously unsuspected complexity in the biosynthetic pathways of Chl which is, perhaps, best ascribed to imperfect stereospecificity of some of the biosynthetic enzymes (Ellsworth and Aronoff, 1969). However, a developmental relationship has also been indicated (Bazzaz and Brereton, 1982). From a comparative point of view, it is interesting to note that the structural variations proposed for the new Chl *a* forms (ring substituents) were first identified in precursors of BChl in *Rp. sphaeroides*, but were not accorded any significance in the final product pool (Jones, 1963).

B. The Acceptor Complexes

Compared to most photochemical reactions in solution, which proceed via excited triplet states, primary events in photosynthesis evolve very rapidly from the excited singlet level, leading to a radical pair state in less than 5 psec ($[P^+CH^-]Q$ in Scheme 1). At this point, and consistent with the great speed of the forward reaction, little energy is lost (Parson and Ke, Chapter 8, this volume). However, stabilization of the charge separation on conventional time scales involves a considerable loss of free energy. Because of the large energy loss and the involvement of less homologous chemical structures (quinones, metalloproteins, etc.) forward electron transfer from the intermediate acceptors is relatively slow (≈ 200 psec). The importance of the "slow" (10–20 nsec) decay of the intermediate states is to allow this forward step to occur with high probability—the metastable charge separation is produced with a quantum yield very close to 1 (≥ 0.98 ; Wraight and Clayton, 1973).

In the purple bacteria and in PSII the electron is stabilized on a primary quinone acceptor (Q_A or Q_I in bacteria, Q in PSII) and is then transferred to a secondary quinone (Q_B or Q_{II} in bacteria, B or R in PSII) (see Fig. 1). (The species Q , in plants, is extremely heterogeneous and exhibits at least four distinct forms— Q_H , Q_L , Q_α , Q_β —distinguishable on the basis of redox properties and kinetic behavior. The relationships between these forms, if any, are obscure.) The primary and secondary quinones reside in an "acceptor quinone complex" of the RC and

act in series to connect the one-electron event of the photoact with the two-electron chemistry of quinones and the subsequent electron transport chain. The primary quinone normally undergoes one-electron reduction at a potential about 0.4 V* higher than that of the reduced intermediate (I/I^-), for which $E_m \approx -0.6$ – -0.7 V in bacteria (Shuvalov *et al.*, 1976; Rutherford *et al.*, 1979; A. W. Rutherford and J. T. Warden, unpublished observations) and in PSII (Rutherford *et al.*, 1981a). Under equilibrium conditions, the primary quinone manifests a pH-dependent midpoint potential, but the implied protonation may be functionally irrelevant and the active, reduced species is presumed to be the anionic semiquinone (Dutton *et al.*, 1973; Knaff, 1975; Prince and Dutton, 1976). At high pH the E_m becomes pH-independent and represents the "operating midpoint potential" of the primary quinone. It has been noted that this limiting value is quite similar for many different bacterial species ($E_{m,pK} \approx -0.17 \pm 0.03$ V), even though the $E_{m,7}$ values vary widely due to large differences in the pK for the reduced form (Prince and Dutton, 1978). This pK is shifted by certain inhibitors of electron transfer from Q_A to Q_B , and it is noteworthy that the pK values in the presence of inhibitor (*o*-phenanthroline) are remarkably similar for all species (pK $\approx 10.0 \pm 0.2$). Since inhibition probably occurs by displacing Q_B (Velthuys, 1981, 1982; Wraight, 1981, 1982), this may indicate a uniformity of the pK for $Q_A^- (H^+)$, and it suggests that species variations in the binding of Q_B are largely responsible for the differences in pK seen in the absence of inhibitors.

Although a variety of chemically distinct quinones are active as electron acceptors in different organisms [plastoquinone (PQ) in PSII, ubiquinone (UQ), and menaquinone (MQ) in the purple bacteria (see Wraight, 1979a)], the basic function of the acceptor complexes is identical. Furthermore, there are important structural similarities. The most intriguing of these is the presence of a high-spin ferrous iron that markedly distorts the semiquinone ESR signals of both Q_A and Q_B (Feher *et al.*, 1972; Okamura *et al.*, 1975; Wraight, 1977, 1978a; Rutherford *et al.*, 1979). In bacteria, instead of the expected free radical ESR signal, the nearby iron atom generates a broad resonance (several hundred gauss wide) centered around $g = 1.82$ – 1.87 (Okamura *et al.*, Chapter 5, this volume). A similar but very poorly resolved signal has recently been reported for PSII (Nugent *et al.*, 1981). Removal of the iron in bacteria and in PSII un.masks a normal semiquinone free radical at $g \approx$

*The convention for oxidation–reduction potentials used throughout this volume, assigns low or negative values to reducing components and high or positive values to oxidizing components. This is the reduction or redox potential scale.

2.00 (Feher *et al.*, 1972; Klimov *et al.*, 1980b). It is possible that the iron is involved in electron transfer from the primary to the secondary quinone, but this is not yet established (see Okamura *et al.*, Chapter 5, this volume). In *Rp. sphaeroides* much evidence suggests that the quinones are not directly liganded to the iron (Butler *et al.*, 1980; Boso *et al.*, 1981).

The metastable electron acceptors of PSI seem very different from the quinones of PSII and purple bacteria (see Fig. 1). Three components have been identified by ESR as active in this region, all with redox midpoint potentials below -0.55 V. Two of them, active as tertiary or even later acceptors ($A_{1,3}$ etc., Parson and Ke, Chapter 8, and Okamura *et al.*, Chapter 5, this volume), have been identified as iron-sulfur (Fe-S) centers. They are probably of the 4Fe-4S type, like bacterial ferredoxins, rather than the 2Fe-2S type found in the soluble ferredoxins of higher plants. The third component ($A_{1,2}$ or X), with a potential below -0.7 V, is more unusual. With principal g -values of 2.08, 1.90, and 1.78, it is not of any recognized class of Fe-S centers and its chemical nature is obscure. Its position in the kinetic sequence of events, being the first non-chlorin structure to receive electrons from P700, suggests a functional analogy with the primary quinone acceptors of PSII and purple bacteria. On the basis of this analogy, Bolton (1977) has suggested that the component X ($A_{1,2}$) might be a quinone-iron complex. Some preliminary extraction studies on PSI particles (J. E. Mullet, unpublished observations) do, in fact, suggest the presence and possible involvement of a quinoid compound in this region, and there is certainly no lack of iron in PSI. However, Mössbauer studies now support the identification of X as a 4Fe-4S center (R. Cammack and M. C. W. Evans, personal communication). An optical spectrum for the reduction of $A_{1,2}$ (X) has been reported as a broad absorption decrease in the blue region of the spectrum (Shuvalov *et al.*, 1979a,b; see Parson and Ke, Chapter 8, this volume). This is *not* in agreement with the formation of a semiquinone but is consistent with an Fe-S center. However, the spectrum is difficult to interpret and has significant contributions from electrochromic effects on the RC pigments. Electrochromic shifts are well established for the PSII and bacterial acceptors (van Gorkom, 1974; Vermeglio and Clayton, 1977).

As yet, data on the green bacteria are still sparse. The primary donor (P840) is certainly BChl *a* but with a midpoint potential ($\approx +0.25$ V) considerably lower than that of the purple bacteria (Prince and Olson, 1976; see right panel in Fig. 1). On the acceptor side, room temperature-observable photochemical turnover ceases with $E_m \approx -0.54$ V (Olson *et al.*, 1976). This has been correlated with the reduction of an Fe-S center

observable in low temperature ESR spectra (Jennings and Evans, 1977). Low temperature work has now revealed more details of the acceptor reactions of *Prosthecochloris aestuarii* (Swarthoff *et al.*, 1981). The method of reductive trapping of acceptor species in the light has shown the involvement of two Fe-S centers and a very low potential component identified as a BChl *a* monomer anion. This is very reminiscent of PSI in plants, but it is probable that the BChl *a* is *not* the primary acceptor and that another species, possibly Bph *c*, precedes it.

The biophysical characterization of *Chloroflexus aurantiacus* is still at an early stage but it is apparent that the spectral properties of the RC are very similar to that of the purple bacteria (Pierson and Castenholz, 1974). The presence of the characteristic green bacterial light-harvesting pigments (BChls *c* and *d*) in chlorosome-like structures, therefore, indicates a remarkable hybrid nature of this organism.

III. Electron Transfer Out of the Reaction Center

A. Acceptor Reactions

The chemistry of primary events in RCs is highly specialized for the rapid and efficient stabilization of photochemically generated charge separation. This metastable state is, however, only the beginning of the energy conservation process and mechanisms have evolved for transfer of the redox equivalents to the electron transport chains that complete the transduction to chemiosmotic free energy.

In PSII and the purple bacteria, transfer of reducing equivalents is achieved through the acceptor quinone complex where the function of the second quinone (Q_B in bacteria, B or R in PSII) appears to be as a two-electron gate, passing reducing equivalents out of the RC only in pairs (Bouges-Bocquet, 1973; Velthuys and Ames, 1974; Vermeglio, 1977; Wraight, 1977).

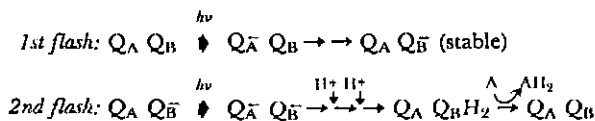

Scheme 2

(The primary donor, P/P^+ , is re-reduced after each flash and is omitted from this scheme. A represents any system of tertiary acceptors, includ-

ing the quinone pool or the electron transport chain.) Binary oscillations in the formation and disappearance of the stable, anionic semiquinone of Q_B , the formation of quinol (Q_BH_2), and the uptake of protons have all been reported in bacterial preparations in agreement with this scheme. Under certain conditions H^+ binding does not oscillate but occurs on every flash, even though the semiquinone continues to oscillate and is still anionic. This has led to the suggested involvement of the protein in the protonation reactions of the quinone complex (Wraight, 1978b, 1979b). In chloroplasts, which also exhibit oscillations in the quinone redox states, binary oscillations in H^+ uptake have rarely been observed and a similar involvement of the protein may be indicated. It is well known that the PSII quinone complex is shielded by a significant diffusion barrier, probably of a lipoprotein nature (Ausländer and Junge, 1974; Junge and Jackson, Chapter 13, this volume), which retards H^+ uptake by several tens of milliseconds. It has therefore been implied that B may be reduced to the dianionic state, B^{2-} (Haehnel, 1976; Diner, 1977). This is in contrast to the proposed scheme for bacteria, in which one H^+ is taken up prior to the second electron, giving the intermediate state Q_BH (Wraight, 1979b). Formation of B^{2-} is thermodynamically improbable and it seems more likely that cryptic protonation occurs beneath the proteinaceous shield. Removal of the shield allows rapid proton uptake (Ausländer and Junge, 1974) but a detailed study of both H^+ uptake and quinone reactions after such treatment has not been reported. Although it has been thought that electron pairing would be necessary for communication between the one-electron photochemical events and the two-electron quinone components of the electron transport chain, the bound nature of active quinones (see Trumppower, 1982) weakens this argument and the purpose of the two-electron gating behavior is somewhat obscure. It has been suggested that restricting the two-electron reduction of Q_B to the RC in situ could ensure that the accompanying protons are taken up from one side of the membrane, a necessary refinement for maximal energy conservation by a chemiosmotic mechanism (Wraight, 1979b). Free mobility of the semiquinone forms, with their relatively low pK values, could otherwise lead to random protonation upon subsequent disproportionation. Additional functional significance for the two-electron gate is provided by various models for the cytochrome $b-c_1$ (b_6-f) complex of the electron transport chain, which is envisaged as a two-electron pathway (Velthuys, 1979; Crofts *et al.*, 1982; Cramer and Crofts, Chapter 9, this volume).

The unusual gating activity of the quinone acceptor complex is associated with atypical physicochemical properties of the quinones (Wraight, 1979b, 1982). In particular, the semiquinones of both Q_A and Q_B are

thermodynamically stable, unlike those of the quinone pool or of similar quinones *in vitro*. This behavior is readily accounted for by strong and preferential binding of the semiquinone states in contrast to the quinone and, especially, the quinol forms of Q_B which are much more weakly bound (Wraight, 1981, 1982). Weak binding would allow exchange of quinone for quinol in the secondary quinone site (B site) of the complex. This has been suggested as a possible mechanism for the transfer of reducing equivalents out of the RC (Okamura *et al.*, 1975; Wraight, 1979b, 1982; Velthuys, 1981, 1982). Further evidence for the exchangeability and relatively weak binding of the secondary quinone comes from the action of inhibitors, including a broad class of potent herbicides that act on PSII. These agents are also active in the purple bacteria and appear to work by displacing the secondary quinone (C. A. Wraight and R. R. Stein, unpublished observations). The interaction is competitive and a similar, though weaker, effect is also seen on the primary quinone. The semiquinone, Q_B^- , on the other hand, is very tightly bound, consistent with the function of the complex in preventing free disproportionation of the semiquinone (Wraight, 1981, 1982). Equivalent studies on PSII have supported the kinetic competence of the secondary quinone binding equilibrium as a mechanism for hydrogen transfer out of the RC (Velthuys, 1981, 1982).

The acceptor reactions of PSI are kinetically less well characterized because of their rapidity and the lack of distinctive optical signals for Fe-S proteins (but see Parson and Ke, Chapter 8; Okamura *et al.*, Chapter 5, this volume). In view of the size and electron capacity of the PSI structure, it seems possible that transfer of reducing equivalents out of the RC complex does not occur until the involvement of soluble ferredoxin ($E_m \approx -0.42$ V). The soluble ferredoxins of all oxygenic photosynthetic organisms, including cyanobacteria, are of the 2Fe-2S type.

The potential complexities involved in linking the one-electron events of photochemistry and subsequent two-electron processes are exemplified by the acceptor quinone complexes of PSII and the purple bacteria. The same dilemma faces PSI as the terminal acceptor is the two-electron couple, $NADP^+/NADPH$ ($E_{m,7} \approx -0.32$ V). However, the mechanism of charge accumulation in PSI appears quite simple in essence, and is mediated by ferredoxin-NADP⁺ reductase [FNR, $E_{m,7} \approx -0.36$ V (Zanetti and Curti, 1980)]. This flavoprotein enzyme forms a reactive complex with ferredoxin, recognizable by a spectral shift in the absorption spectrum of ferredoxin (Nelson and Neumann, 1968), and has been shown to mediate a rapid dismutation of one-electron states from ferredoxin and another, possibly earlier, component (Bouges-Bocquet, 1978a,b, 1980). It therefore provides a kinetically competent path

for reductive cooperation between PSI units. FNR has a tendency to dimerize (Shin and Oshino, 1978) that may be relevant to the dismutation reaction.

The acceptors, prior to NAD^+/NADH , for noncyclic electron transport in green bacteria are essentially unknown. Ferredoxins occur in these species, and that from *C. limicola* has been partially characterized. It appears to be a typical bacterial ferredoxin with $8\text{Fe}-8\text{S}$, i.e., two $4\text{Fe}-4\text{S}$ centers (Yasunobu and Tanaka, 1980).

B. Donor Reactions

The most immediate prediction of van Niel's hypothesis was that the O_2 evolved in plant photosynthesis derives not from CO_2 but from H_2O . Thus, bacteria "are capable of reducing CO_2 photosynthetically without the liberation of oxygen, because O_2 is the dehydration product of the H donor only in the case that this latter is H_2O [van Niel, 1931, p. 83]." This is now widely accepted and isotopic ^{18}O -labeling experiments have been generally consistent with this notion (Ruben *et al.*, 1941; Stemler and Radmer, 1975). However, they have never provided quite the unequivocal support that might be desired (Warburg, 1964; Metzner, 1975) and the possibility remains that CO_2 may be involved. Such participation, however, would be quite unrelated to the fixation of CO_2 represented by the overall equation of photosynthesis. This still lingering question has generated some alternatives for the mechanism of O_2 production. The more widely accepted views of the O_2 -evolving machinery and the nature of the so-called S states are reviewed by Wydrzynski (Chapter 10, this volume), and the phenomenon of thermoluminescence, a complex probe of the energy levels of the O_2 -evolving system, is discussed by Inoue and Shibata, Chapter 11, also in this volume.

Oxygen evolution is the end result of donor reactions that contribute toward the stabilization of the charge separation in PSII. It is, perhaps, the one truly unique aspect of plant photosynthesis and, for that reason, offers little opportunity for comparative analysis. However, the pace of events in this area is very rapid and significant parallels with other redox systems, perhaps including cytochrome oxidase, may soon become apparent. In all other photosystems (PSI, purple, and green bacteria), there is a great deal of functional homology between the various donors.

In all purple and green photosynthetic bacteria, in most prokaryotic PSI (cyanobacteria), and in some eukaryotic PSI (e.g., *Euglena*) the immediate donor is a *c*-type cytochrome (Cyt). In bacteria, two structurally distinct cases are encountered, with no apparent phylogenetic signifi-

cance (Dutton and Prince, 1978). In some species, including *Chromatium* (*Chr.*) *vinosum*, *Rp. viridis*, *Rp. palustris*, and *Thiocapsa pfennigii*, the RC is tightly associated with two distinct, hydrophobic Cyts *c*, comprising up to four hemes. Both types are capable of rapid ($t_4 \approx 1 \mu\text{sec}$) electron transfer to the RC but are distinguished by their very different E_m values. A high potential form ($E_m \approx 0.3\text{--}0.35 \text{ V}$) is thought to be involved in normal photosynthetic turnover. The low potential species ($E_m \approx 0 \text{ V}$) is re-reduced only very slowly and is of uncertain function, possibly related to redox poisoning of the electron transport chain via endogenous substrates (see Fig. 1). In *Chr. vinosum*, re-reduction of the active, high potential Cyts is rapid and occurs via a small, soluble, *c*-type Cyt (van Grondelle *et al.*, 1977).

A different donor configuration is found in e.g., *Rp. sphaeroides*, *Rp. capsulata*, and *Rhodospirillum* (*Rs.*) *rubrum*. For these species which lack the bound, hydrophobic Cyts *c*, the immediate donor is a small, soluble Cyt *c*. Studies on *Rp. sphaeroides* have shown Cyt c_2 to be in a binding equilibrium with the RCs (Overfield *et al.*, 1979; Overfield and Wraight, 1980a,b; Rosen *et al.*, 1980). At low concentrations, the Cyt oxidation kinetics following a flash are second order, indicating a diffusional approach, and surface diffusion has been implicated (Overfield and Wraight, 1980a,b). At high concentrations, however, the rate becomes limited ($t_4 \approx 200 \mu\text{sec}$) by the binding event itself. Cytochrome that is already bound before the flash is oxidized very rapidly ($t_4 \approx 3 \mu\text{sec}$). Biphasic kinetics are generally observed indicating contributions from both initially bound and unbound cytochromes.

The green sulfur bacteria, *Chl. limicola* and *Prosthecochloris aestuarii*, appear to be intermediate between these two donor arrangements. The reaction center is associated only with a high potential, membrane-bound Cyt c_{553} (Olson *et al.*, 1976; Swarthoff and Ames, 1979). There are, in addition, several candidates for a soluble Cyt *c* (Dutton and Prince, 1978).

Regardless of the donor configuration, the mobile *c*-type Cyts are all closely related to mitochondrial Cyt *c* (Dickerson, 1980), and serve to mediate lateral electron transfer between two large, integral membrane proteins—the RC and the Cyt *b*-containing complex of the electron transport chain (Fig. 1).

The immediate donor to PSI also appears to be a small mobile carrier. In many cyanobacteria and in some eukaryotic algae, including *Euglena gracilis*, the donor is a Cyt *c*, very similar to the bacterial/mitochondrial type. In higher plants and most algae this function has been taken over by the copper protein, plastocyanin. The functional equivalence of these two donors is clearly established by those species of cyanobacteria and

eukaryotic algae which have both. The dominant metalloprotein is determined largely by nutritional status, i.e., Cu versus Fe supply. The kinetic behavior of plastocyanin is remarkably similar to that of the soluble Cyt *c* in bacteria (Haehnel *et al.*, 1980a,b). Biphasic kinetics are observed, arising from a diffusional approach and reaction from a bound state, and the rate constants for the fast and slow phases are very similar to those for Cyt *c*₂ in *Rp. sphaeroides*.

Plastocyanin from higher plants is an acidic protein but, like the soluble, bacterial, and algal Cyts (Bartsch, 1978), a range of pI values from 4 to 9 are found throughout the algae and cyanobacteria (Ellefson *et al.*, 1980). Since biological membranes are significantly negatively charged, it might be expected that ionic screening effects would be important in governing the interaction between these donors and the RCs. Experimentally this is true, but it is noteworthy that the bacterial Cyts are periplasmic proteins, actually outside the cell, and are probably in a low-to-moderate ionic strength medium (most species are fresh water denizens). The ionic constitution of the inside of a chloroplast thylakoid, where plastocyanin is probably located, is uncertain but it must be quite close to that of the stroma, i.e., high, as thylakoids are rather permeable to ions (see Junge and Jackson, Chapter 13; and Ort and Melandri, Chapter 12, this volume). It has been reported that plastocyanin interacts with P700 via a specific binding site on subunit III of the PSI complex and requires high ionic strength (Haehnel *et al.*, 1980b). It should be remembered, however, that the thylakoid interior becomes quite acid during illumination and the net charge on plastocyanin, during steady state turnover, must be very different from that obtaining in studies on solubilized particles at near neutral pH. The physiological relevance of the ionic requirements for plastocyanin binding is, therefore, unclear.

IV. The Electron Transport Chain

A. Linear and Cyclic Flows

Van Niel's prediction of O₂ evolution from H₂O clearly arose from the presumption of a linear, light-driven flow of redox equivalents in both plants and bacteria. Thus, organic substrates for the purple bacteria would be completely oxidized to CO₂ to yield [H] for the fixation of a roughly equivalent amount of CO₂ at the level of carbohydrate (CH₂O). It is ironic that this feature of his hypothesis, so important as it was for the analogy with plants, should prove wrong. Furthermore, an

alternative view of bacterial photosynthesis, much closer to the opinions of today, was advocated even then by Gaffron (1934, 1942). It is probably fortunate for the progress of photosynthesis research that Gaffron's suggestions were not vindicated earlier!

It is now known that the reducing power available from the RCs of purple bacteria ($E_m(Q_A/Q_{A'}) \approx -0.17$ V) is insufficient to reduce CO_2 directly [$E_{m,7}(CO_2/CH_2O) \approx -0.45$ V] or even NAD^+ [$E_{m,7}(NAD^+/NADH) \approx -0.32$ V] (Knaff, 1978; Prince and Dutton, 1978). Instead of the envisaged linear electron flow from H donor to CO_2 , a cyclic electron transport system (Fig. 1; also see chapter by Cramer and Crofts, Chapter 9, this volume) conserves energy exclusively through chemiosmotic pathways leading to ATP synthesis ("cyclic photophosphorylation"; see Ort and Melandri, Chapter 12, this volume). Reducing power can be generated, as needed, by reversed electron transport and, perhaps, by ATP-driven transhydrogenations from weaker reductants including growth substrates (Knaff, 1978). However, organic substrates are generally assimilated more or less intact, requiring mostly ATP as the energy source and with only minor alterations to tailor their reduction level to that of the cellular average. During such photoheterotrophic growth, little or no CO_2 is fixed for purposes of carbon procurement, and the minor adjustments to the reduction level of these substrates can result in either CO_2 uptake or release.

The purple photosynthetic bacteria are also capable of photoautotrophic growth using inorganic, sulfur-containing electron donors (Pfennig, 1977). This is the dominant life-style in Chromatiaceae, but even then cyclic photophosphorylation is the only mechanism of light energy transduction. The green sulfur bacteria (Chlorobiaceae), on the other hand, are considered capable of both noncyclic electron flow from substrate to NAD^+ , and cyclic flow (right hand, Fig. 1) (Knaff, 1978). The electron transfer pathways of this family are poorly characterized, but the involvement of low potential Fe-S centers in the acceptor region is reminiscent of PSI which, of course, is also capable of direct reduction of pyridine nucleotide ($NADP^+$).

B. The Cytochrome $b-c_1$ and b_6-f Complexes

Although van Niel's hypothesis fails at the level of gross comparison of bacterial cyclic and plant noncyclic electron transport, the homology at the molecular level is striking and is further strengthened by inclusion of respiratory systems in the comparison. The central feature is a membrane protein complex which, in plants and the purple bacteria, at least, is remarkably similar to complex III of mitochondria, the ubiq-

uinone-Cyt *c* oxidoreductase (Dutton and Wilson, 1974; Packham *et al.*, 1980; Cramer and Crofts, Chapter 9, this volume). The complex contains two *b* Cyts, a bound *c*-type Cyt (*c*₁ or *f*), quinone, and a high potential Fe-S center (2Fe-2S), known as the "Rieske" iron-sulfur protein (Fig. 1). (For generic usage it will be referred to, in this chapter, as the Cyt *b*-*c*₁ complex.) At least some of these components are also present in green bacteria. Various experimental developments have led, in recent years, to rapid changes of opinion on the mechanism of the photosynthetic *b*-*c*₁ complexes and several other models have been proposed by workers in the mitochondrial field. In fact this subject has taken on the character of a modern "Bengazi gallop." The following paragraphs trace these recent developments.

The electrogenic, proton-translocating function of the Cyt *b*-*c*₁ complex is now well recognized in photosynthetic bacteria (see Dutton and Prince, 1978; Wraight *et al.*, 1978) and in chloroplasts (Bouges-Bocquet, 1977, 1980, 1981; Velthuys, 1978, 1979; Crowther *et al.*, 1979) and, as in mitochondria, has defied description in terms of the simple redox loops originally proposed by Mitchell (1966). Its kinetic and stoichiometric peculiarities led to the ingenious proposal of the Q-cycle mechanism (Mitchell, 1975, 1976). In all systems, Q-cycle mechanisms have enjoyed some success, particularly in accounting for the H⁺/e⁻ ratio of 2 for this site, and in explaining the phenomenon of oxidant-induced reduction of Cyt *b*. A plausible Q-cycle scheme for noncyclic electron flow in chloroplasts is shown in Fig. 2a, and the potential for compactness is demonstrated for a cyclic pathway in Fig. 2b. The Q cycle is characterized by an electrogenic transfer of equivalents involving two distinct *b* Cyts (*b*₁, *b*₂) acting in series, and by the operation of Cyt *c* (*f*) in parallel with the *b* Cyts. Thus, quinol is oxidized by one low potential (Cyt *b*₁) and one high potential (Cyt *c* or *f*) component. The electron that goes to Cyt *b*₁ is recycled in a purely electrogenic, proton-translocating function. The electron that goes to Cyt *c* (*f*) contributes the net transfer of reducing equivalents through the cycle.

One of the most prominent failings of the Q cycle is its inability to account, simply, for the close coupling between Cyt *b* oxidation and Cyt *c* (*f*) reduction (Prince and Dutton, 1975; Velthuys, 1979). This is readily accounted for by traditional, linear schemes in which Cyt *b* precedes Cyt *c*. Furthermore, the centrally active quinone of the *b*-*c*₁ complex in bacteria and mitochondria (Q₂) and in plants (U) has been characterized as an *n* = 2 redox component, i.e., with a thermodynamically unstable semiquinone (Prince and Dutton, 1977; Takamiya *et al.*, 1969; Crowther and Hind, 1980; Bouges-Bocquet, 1981; Matsuura *et al.*, 1981). In a Q-cycle mechanism, production of semiquinone, the reductant for Cyt *b*,

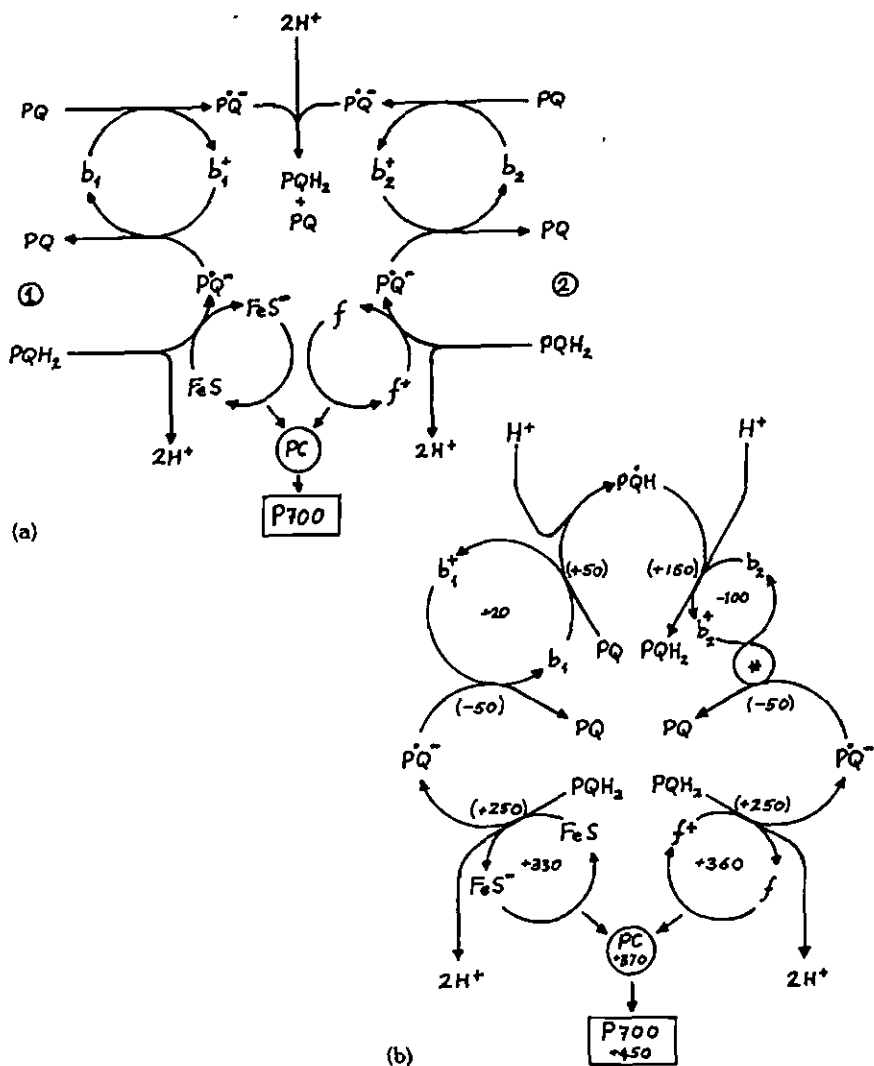

FIG. 3. Parallel Q cycles. (a) Components taken from chloroplast literature. Complete turnover of the Cyt b_6 - f complex requires input from two plastoquinols with the net passage of two reducing equivalents from plastoquinol to P700. In order to account for reduction of Cyt b prior to that of Cyt f , an ordered process is required—the b_1 : $Fe-S$ Q cycle is activated first (1) followed by the b_2 : f Q cycle, b_1 and b_2 may both be Cyt b_6 . (Adapted from Velthuys, 1979.) (b) An alternative version of the parallel Q cycle model showing the flexibility for connecting the various plastoquinone-plastoquinol terminals. A single plastoquinone is shown as accepting reducing equivalents from the two b cytochromes (b_1 , b_2). The numbers indicate midpoint potential values (E_m or $E_{m,7}$) in millivolts; those in parenthesis are estimated. The values shown for the two b cytochromes are appropriate for Cyt $b_{559} - LP$ (+20 mV) and Cyt b_6 (-100 mV). The asterisk (*) indicates a possible mismatch in E_m values available for actual components.

achieved, however, by having the first quinol interaction favor the b_1 : Fe-S branch. Donation by a second quinol to the b_2 - f branch subsequently reduces Cyt f but also provides a second reducing equivalent for the dismutation of two semiquinones (see the top of the figure) and the consequent reoxidation of the b Cyts. Thus, Cyt b oxidation and Cyt f reduction are coupled.

Both halves of this scheme perform the same sequence of reactions *vis-à-vis* the quinone redox species and could have the same thermodynamic requirements. It is noteworthy that the two Cyts b_6 of the b_6 - f complex of chloroplasts are apparently identical (Hurt and Hauska, 1981). This is in contrast to the two distinct b Cyts of the b - c_1 complexes of bacteria and mitochondria. Another b Cyt (Cyt b_{559} LP) has been reported as associated with the chloroplast complex (Cramer and Whitmarsh, 1977; Rich and Bendall, 1980) but it is not found in a purified complex (Hurt and Hauska, 1981). A tighter connection between the two branches can be provided by joining the two Q cycles through the semiquinone (Fig. 3b). In this condensed version it is clear that a number of possibilities exist for the passage of reducing equivalents.

In *Rp. sphaeroides* and *capsulata* the kinetics of the b - c_1 complex have been resolved in greater detail and were reported to be still discrepant with a Q-cycle formulation, even after allowing for involvement of the Rieske Fe-S protein (Crofts and Bowyer, 1980). This led Crofts and co-workers to suggest a new kinetic sequence which incorporates Velthuys' proposal of parallel paths but has a number of distinctive features of its own (Crofts *et al.*, 1982; Cramer and Crofts, Chapter 9, this volume). Most notably, it is distinct from Q-cycle formulations in providing an essentially linear path between the b Cyts and Cyt c (Fig. 4). These parallel pathway models are two-electron schemes and Crofts has pointed out that this fits rather well with the observed excess of RCs over b - c_1 (approx. 3:2) (Prince *et al.*, 1978; van den Berg *et al.*, 1979; Bowyer *et al.*, 1980; Crofts *et al.*, 1982). However, the excess would follow equally well from the two-electron gate of the RC quinone complex, regardless of the mechanism of the b - c complex. In either case, close approach to a 2:1 stoichiometry, as now reported by Crofts' group (Crofts and Meinhardt, 1982), would seem to be necessary only under conditions of light saturation, and variability might be more generally expected.

In order to permit the successful operation of the b -Cyts in the positions assigned to them in Fig. 4, it is necessary to suppose that they each act with two distinct redox properties. It was proposed that the midpoint potentials of the b Cyts are perturbed by the oxidation of Cyt c_1 and the Fe-S protein (Crofts *et al.*, 1982; see Cramer and Crofts, Chapter 9, this volume). This raises, once again, the question of the significance of

of P870 in *Rp. sphaeroides* chromatophores was found to cause large downward shifts in the pK of reduced Cyt b_{50} ($E_m \approx 50$ mV) and of the unidentified components responsible for proton binding (H_1^+ and H_{II}^+) (Petty and Dutton, 1976; Petty *et al.*, 1979). A large, upward shift in the pK of Q_BH , induced by the appearance of Q_A^- , has been described in RCs from *Rp. sphaeroides* (Wraight, 1979b). A fundamental connection exists between protonation (pK) and redox (E_m) properties and these observed pK shifts imply correlated shifts in E_m (Petty *et al.*, 1979; Wraight, 1979b, 1982). Thus, the pK shift for Q_BH , which is at least 4 pH units, could indicate a negative shift in the E_m of Q_B/Q_B^- of at least 240 mV, i.e., -60 mV per pH unit. Clearly, transient alterations of this magnitude in the thermodynamic parameters of a system could dramatically influence the kinetic behavior and feasibility of pathways. The transient changes in the midpoint potentials of the *b* Cyts suggested by Crofts for the $b-c_1$ complex, are equivalent to the earlier observation of flash-induced pK shifts (Petty *et al.*, 1979). It is interesting to note that the E_m s of the *b* Cyts of chloroplasts are pH-independent over a wide range (Cramer and Whitmarsh, 1977; Rich and Bendall, 1980). This does not, however, rule out midpoint potential changes similar to those proposed for the bacterial $b-c_1$ complex.

However, Crofts has now reconsidered the $b-c_1$ kinetics in *Rp. sphaeroides* and concluded that they are, after all, compatible with a Q cycle (Crofts and Meinhardt, 1982)! He suggests, in fact, that a successful Q-cycle interpretation of the bacterial system depends, critically, on the rather specific properties observed for the components, such as relative E_m values and stoichiometries. Returning, therefore, to the Q-cycle description, Fig. 5 provides a synthesis of current data on the $b-c_1$ complex of *Rp. sphaeroides*. An unidentified component ($Q_c?$) is shown as responsible for returning the electron that cycles electrogenically through the Cyt *b* loop. In mitochondria, a ubiquinone (Q_c) with a fairly stable semiquinone— $E_m(Q/Q^-) \sim +30$ mV (pH-independent); $E_{m,7}(Q/QH_2) \approx +170$ mV (-120 mV/pH unit)—is associated with the $b-c_1$ complex and is suggested to play this role (de Vries *et al.*, 1980; Ohnishi and Trumpower, 1980). The semiquinone of Q_c , however, does not appear to be sufficiently stable for this portion of the chain to work satisfactorily without invoking some form of dismutation. The original Q cycle achieved this by pairing this electron up with one from the input point, i.e., the RC, to give fully reduced quinol (see e.g., Fig. 2). Bacterial and PSII RCs, however, seem to function as two-electron sources. It is possible, of course, that the RC may alter its operation depending on the redox state of the $b-c_1$ components. Dutton and co-workers, in particular, have favored the notion of more than one possible electron path to

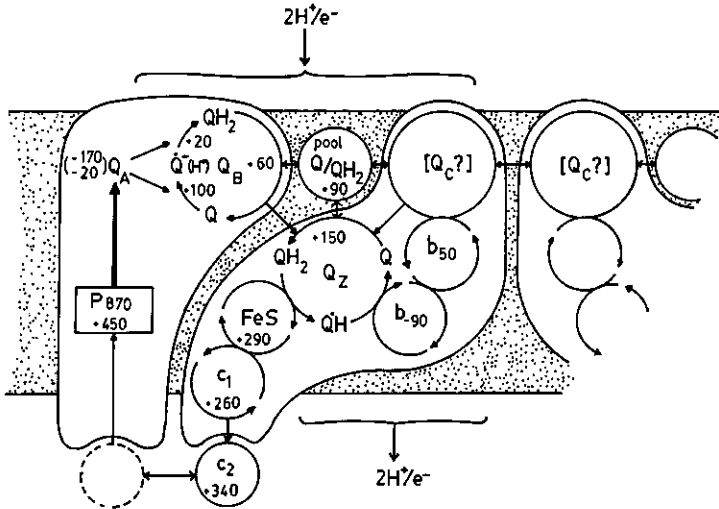

FIG. 5. A contemporary Q cycle for light-activated cyclic electron transport in *Rp. sphaeroides*. E_m values ($E_{m,7}$ when pH dependent), taken from the literature, are given in mV. Q_A is assigned two values— $E_{m,7} = -20$ mV as determined in equilibrium titrations, and $E_{m,pK} = -170$ mV, suggested as the “operating” value (see text for details). Protolytic reaction sites are still unclear and are not specified. Double headed arrows (\leftrightarrow) indicate possible involvement of diffusional exchange. Single arrows (\rightarrow) represent transfer of reducing equivalents. Heavy arrows \Rightarrow represent primary events. See text for further details.

Cyt b_{50} in *Rp. sphaeroides*, depending on redox potential and inhibitor status (van den Berg, 1979; Matsuura and Dutton, 1981; Matsuura *et al.*, 1981; O’Keefe and Dutton, 1981).

A second possibility for the dismutation of Q_c^- could involve cooperation between two $b-c_1$ complexes; this is indicated in Fig. 5. It is noteworthy that dimeric forms of the mitochondrial $b-c_1$ complex have been reported (von Jagow *et al.*, 1977; de Vries *et al.*, 1979). This is clearly similar to Velthuys’ model (Velthuys, 1979), where plastoquinone functions as Q_c (see Fig. 3). Naturally, a conservative view of biochemical evolution favors the existence of a single, ubiquitous mechanism for the Cyt $b-c_1$ pathway. A glance at Figs. 3b and 4 reveals that the two schemes are topologically very similar. By interchanging the sites of action of the semiquinones and the quinone and quinol in the central region of Fig. 3b, the two Q cycles may be coalesced entirely. Now, introducing reducing equivalents in at the top, instead of out, yields Fig. 4! Although probably no more than a sleight of hand, this suggests that even with a single basic structure, different modes of action may be encountered under different conditions. There are, indeed, indications that the elec-

trogenic activity of the b_6-f complex in chloroplasts operates only under conditions of low, net energization (Bouges-Bocquet, 1981) and H^+/e^- stoichiometries for noncyclic electron transport have long been reported to vary with energization and external pH (Dilley and Giaquinta, 1975). Similarly, there have been reports that Cyt $b-c_1$ and Cyt b_6-f complexes can act as semiquinone dismutases, implying that the site specificity for the semiquinones is not absolute (Olsen *et al.*, 1980; Mitchell, 1982). Thus, in spite of the considerable ingenuity and effort expended in the recent flurry of $b-c_1$ models, it is worth considering that the pace of experimental events is still faster and that current models do not even incorporate all the available data. Matsuura and Dutton (1981) have recently reported another possible quinone species in *Rp. sphaeroides* and in mitochondria, with a midpoint potential about 30 mV more positive than Q_z . Chemical reduction of this component blocks the flash-induced reduction of Cyt b_{50} which, at high potentials, is slow anyway. Further lowering the redox potential, of course, causes the onset of rapid Cyt b_{50} reduction as Q_z becomes chemically reduced before the flash ($E_{m,7} \approx 150$ mV, $n = 2$).

C. Lateral Transport of Reducing Equivalents

The connection between Cyt $b-c_1$ complexes and the donor side of the photoact, i.e., P870 or P700, is accomplished by a soluble component, Cyt c or plastocyanin, as described in Section III,B. The input of reducing equivalents to the Cyt $b-c_1$ complex apparently occurs from a quinol. If turnover of the electron transport chain depended on significant diffusion of quinone and quinol, one would expect a marked dependence of the kinetics on the membrane "concentration" of quinones, i.e., the "pool." Extraction studies do not support this, either in bacteria (Takamiya and Dutton, 1979; Takamiya *et al.*, 1979) or in chloroplasts (Bishop, 1959).

In bacteria, with a single photoact and a cyclic electron transport pathway, a rather close association between RC and Cyt $b-c_1$ complex is probable and quinol transfer can be readily envisaged as involving only a minor translocation of Q_BH_2 (see Section III,A). In chloroplasts, however, there are strong indications that PSII tends to segregate into the appressed membrane regions of the grana stacks, and that PSI segregates preferentially into the unstacked regions of the grana and into the stroma lamellae (Andersson and Anderson, 1980; Kaplan and Arntzen, Chapter 3, this volume). Thus, although only a fraction of the total PSII and PSI are completely segregated, there is a tendency for long range separation between the two photosystems.

The major linkage between the two could be provided by either plastoquinone or plastocyanin and, in spite of the older extraction studies, plastoquinone seems to be the preferred candidate (Anderson, 1981). If this were so, one might expect the Cyt b_6-f complex to be predominantly associated with PSII. In fact, this is not the case. On a Chl basis, the PSI-enriched stroma lamellae are slightly deficient in Cyts b_6 and f compared to the PSII-containing grana fragments (D. R. Paterson and C. A. Wraight, unpublished observations). Since Cyt b_6-f complex is also involved in cyclic electron transport around PSI, this result supports a roughly even distribution of the complex between PSII and PSI in the grana, for noncyclic flow and PSI in the stroma lamellae for cyclic flow. The total Cyt b_6-f content of intact thylakoids is close to one complex per chain (Whitmarsh and Cramer, 1979). Thus, even distribution would give about one-half complex per photoact and both noncyclic and cyclic involvements of the complex could proceed with two-electron inputs from the RCs via plastoquinol. This is in agreement with the observed Cyt $b-c_1$: RC stoichiometries in *Rp. sphaeroides* (Prince *et al.*, 1978; van den Berg *et al.*, 1979; Crofts *et al.*, 1982) and with current notions of mechanism for this complex in bacteria (Crofts *et al.*, 1982; Crofts and Meinhardt, 1982) and chloroplasts (Velthuys, 1979), and the two-electron gating activities of RCs in bacteria and PSII (Wraight, 1982).

The heterogeneity of the PSII acceptor systems is profuse and well documented in terms of primary acceptor properties (Cramer and Butler, 1969; Melis and Homann, 1975; Horton and Croze, 1979; Joliot and Joliot, 1979; Thielen *et al.*, 1981; Thielen and van Gorkom, 1981). Some of this complex heterogeneity may originate in the structural dimorphism of the thylakoid membranes—grana versus stroma lamellae—but this is not established (Kaplan and Arntzen, Chapter 3, this volume). Not all forms are necessary for normal photosynthetic activity (Horton and Naylor, 1979; Bowes *et al.*, 1981). In bacteria, heterogeneity has been indicated in isolated RCs (Wraight, 1979b) and is also frequently apparent in the RC population in situ. In chromatophores of *Rp. sphaeroides*, O'Keefe *et al.* (1981) report that under certain conditions oscillations of semiquinone formation in the acceptor quinone complex are only observed for RCs in excess of the $b-c_1$ complex. In *Rp. capsulata*, Bowyer (1980) has observed that the redox properties of roughly half the RCs are more strongly perturbed by the herbicide, ametryn, than the others. Furthermore, full oscillatory activity of all RCs appears to titrate in only at very high redox potentials (> 300 mV), which do not correspond with any known component of the electron transport system (Bowyer, 1980; O'Keefe *et al.*, 1981). On the other hand, good oscillatory function has been reported at lower potentials (< 300 mV) in the pres-

ence of very high concentrations of certain redox mediators (Barouch and Clayton, 1977; DeGroot *et al.*, 1978). Lack of redox equilibration might account for some of these anomalies and, indeed, has been invoked in accounting for some aspects of the redox properties of the acceptor quinones in PSII (Thielen and van Gorkom, 1981). However, some heterogeneity, both in bacteria and in PSII, might arise from the stoichiometry of the RCs, in excess over the $b-c_1$ or b_6-f complexes. A tight binding between RC and $b-c_1$, dependent on the redox state of the acceptor quinone complex (and, perhaps, the $b-c_1$ complex), could generate marked differences in the redox properties of Q_B and Q_A between associated RCs and excess, unassociated RCs, providing the two populations did not exchange. Lack of exchange between oscillating and non-oscillating RCs in a mixed population has been reported by O'Keefe, *et al.* (1981).

For both locations of the Cyt b_6-f complex, in the grana or stroma lamellae, the major mobile carrier can be plastocyanin, whereas plastoquinone need only undertake minor excursions. This view of plastoquinone as having limited mobility is supported by the observed tendency for long prenyl side chain quinones to aggregate in membranes (Futami *et al.*, 1979). Whether or not plastocyanin diffuses freely in the luminal phase of the thylakoid or loosely associated with the inner surface of the membrane, comparison with studies on Cyt c and c_2 diffusional mobility (Overfield and Wraight, 1980a,b) indicates that long range lateral transport of reducing equivalents can be readily achieved by plastocyanin in the time required—Cyt f is oxidized with $t_{1/2} = 100-400 \mu\text{sec}$ (Haehnel *et al.*, 1980a; Whitmarsh *et al.*, 1982). For cyclic flow, electron transfer from the acceptor side of PSI to the b_6-f complex might be similarly dominated by the lateral diffusion of a peripheral protein such as ferredoxin or a reductase.

V. Energy Transduction

A. The Proton Motive Force as Intermediate

It now seems well established that energy transduction in photosynthesis and respiration occurs by an essentially chemiosmotic mechanism in which a protonic potential difference across the membrane mediates the free energy transfer from redox reactions to ATP synthesis (Mitchell, 1979). There is, however, still some question over the extent of delocalization of this proton motive force (pmf or Δp) (Ort *et al.*, 1976; Kell, 1979; see Ort and Melandri, Chapter 12; and Junge and Jackson, Chapter 13, this volume). Strictly speaking one may wish to reserve the

term *chemiosmotic* for a transmembrane pmf that is fully delocalized into the bulk phases, but such precision seems to have little real merit. Furthermore, it is questionable whether the small intravesicular spaces of coupling systems, e.g., chromatophores, and thylakoids, have any true bulk phase (Junge, 1977; Junge and Jackson, Chapter 13, this volume). Studies with water-soluble ESR spin labels have indicated that the apparent viscosity of the inner aqueous phase is at least 10 times higher than normal bulk water (Berg *et al.*, 1979). Adenosine triphosphate synthesis can certainly be driven by bulk-phase gradients established by acid-base and salt-jump techniques (see A. Jagendorf, in Govindjee, 1975). Under conditions of active electron and proton flux, however, things may not be quite so straightforward. Several attempts have been made to go beyond the quasi-equilibrium approach to bioenergetics and to develop an irreversible thermodynamic framework for the analysis of bioenergetic fluxes (Kell, 1979; Rottenberg, 1979; Walz, 1979). It is felt that the consideration of the coupling between fluxes may reveal the existence of kinetically preferred pathways for H^+ ions, e.g., interfaces, structured water, H bonding, and so forth, and that apparent discrepancies can be accounted for by a sufficiently realistic analysis. A realist, however, would probably admit that, so far, remarkably little has come from the application of nonequilibrium thermodynamics that was not already apparent from "pseudo-equilibrium" thermodynamics.

The pmf of mesophilic bacteria and mitochondria is generally dominated by a large membrane potential component ($\Delta\psi$). This is considered appropriate because the internal pH must be maintained at a constant value for enzymatic and other metabolic activities. Chloroplasts, on the other hand, operate in the steady state with a large pH gradient (ΔpH) and negligible $\Delta\psi$ (see Ort and Melandri, Chapter 12, McCarty and Carmeli, Chapter 14, and Junge and Jackson, Chapter 13, this volume). It does not seem adequate to justify this simply on the grounds of low metabolic activity within the thylakoid lumen, especially since ion impermeability is a more fundamental property of biological membranes than leakiness (Papahadjopoulos, 1972). Furthermore, the low internal pH (~ 5 in high light) (Bamberger *et al.*, 1973; Renger *et al.*, 1976) must significantly raise the E_m for the protolytic reactions of the water-splitting enzyme. It has frequently been suggested that the light-induced pH rise in the stroma and the accompanying release of Mg^{2+} ions from the thylakoids can exert a regulatory effect on enzyme activities in the stroma, and most of the enzymes of the reductive pentose phosphate cycle do, indeed, have rather high pH optima and requirements for Mg^{2+} ions (see J. A. Bassham and B. B. Buchanan, Chapter 6, in Govindjee, Vol. II, 1982). It is more palatable to suppose, however,

that this does not simply reflect a useful adaptation of the enzymes to the vicissitudes of an inept membrane, but that the membrane, too, has been appropriately modified to allow the substitution of ΔpH for $\Delta\psi$ and to reversibly bind Mg^{2+} .

B. Stoichiometries of the Coupling Process

Many attempts have been made in the past to test the chemiosmotic hypothesis on energetic grounds by determining if the total pmf was sufficient to account for observed phosphate potentials. With the general acceptance of the hypothesis, these same measurements are now being used to determine the various stoichiometric factors H^+/e^- , H^+/ATP , and so on. In mitochondria, the H^+/ATP ratio is generally accepted as 2. In photosynthetic bacteria this value is consistent with most of the energetic data (Bashford *et al.*, 1979), but higher values have been indicated by studies at low energetic levels (Kell *et al.*, 1978).

In chloroplasts, the H^+/ATP ratio is considered not likely to be less than 3 (see McCarty and Carmeli, Chapter 14; and Ort and Melandri, Chapter 12, this volume), but this number is still far from firm. H^+/e^- ratios have proved elusive and, for noncyclic electron transport, values of 1–5 have been reported, with 2–3 considered most acceptable. The best estimate for H^+/ATP is 3 (see McCarty and Carmeli, Chapter 14; and Ort and Melandri, Chapter 12, this volume). Until recently $\text{H}^+/\text{e}^- = 2$ was generally accepted, but the finding of an electrogenic site in the Cyt b_6-f complex suggests the value should be 3 as has been reported by Velthuys (1978), and D. Crowther and G. Hind (unpublished observations). Other studies, however, do not support this (Saphon and Crofts, 1977; Hope and Moreland, 1979; Olsen *et al.*, 1980). The uncertainties in both H^+/ATP and H^+/e^- ratios are too great to settle the question of the $\text{ATP}/2\text{e}^-$ ratios expected and, in fact, all the observed ratios from 1 to 2, are possible, including nonintegral values (see Ort and Melandri, Chapter 12; McCarty and Carmeli, Chapter 14; and Junge and Jackson, Chapter 13, this volume). Variable $\text{ATP}/2\text{e}^-$ ratios have always been accountable by invoking a variable contribution of cyclic activity. The variable involvement of the Cyt b_6-f complex in noncyclic electron flow has also been suggested. Bouges-Bocquet (1981) has provided some evidence that coupled electron flow through the Cyt b_6-f electrogenic site only occurs under conditions of low energization, thereby allowing the H^+/e^- ratio to vary from 3 to 2.

Variability in the H^+/ATP ratio generally has not been considered but it is certainly a possibility. Ort and co-workers, measuring ATP yields of single flashes, have observed that the $\text{ATP}/2\text{e}^-$ ratio per flash in-

creases during a flash series. Initially $\text{ATP}/2e^- \approx 0$ due to the sub-threshold level of Δp . After a few flashes, ATP synthesis is observed with $\text{ATP}/2e^- \approx 1.1$ – 1.2 , and continues at this level for 20 or so flashes (Graan *et al.*, 1981; see Ort and Melandri, Chapter 12, this volume). After about 25 flashes, preliminary measurements indicate that the $\text{ATP}/2e^-$ ratio may increase to 1.3–1.5 (D. R. Ort, personal communication). This is in the wrong direction to be accounted for by involvement of the Cyt b_6 – f pathway only at low Δp values, as described by Bouges-Bocquet. It could be accounted for by a change in the H^+/ATP ratio of the coupling factor, induced either by increasing ΔpH , decreasing $\Delta\psi$ or by associated changes in the ionic and pH conditions of the bulk phases. Considerable adaptive significance can be conceived for variable H^+/ATP ratios, in general.

C. The ATPases

Measurement of the steady state pmf in chloroplasts is simplified somewhat by the virtual absence of $\Delta\psi$. Many studies have now shown a threshold ΔpH for ATP synthesis of 2.4–2.7 units. For $\text{H}^+/\text{ATP} \sim 3$, these values correspond to threshold phosphate potentials of 10–12 kcal mole⁻¹ (42–50 kJ mole⁻¹). Since the activated coupling factor (CF_1) necessarily catalyzes both ATP hydrolysis and ATP synthesis, an energetic threshold for the activation of CF_1 may be an effective way of conserving the phosphate group transfer potential in the stroma under dark or low light conditions. It has long been known that activation of chloroplast ATPase activity can be accomplished by combined membrane energization and the presence of a reducing, usually sulfhydryl, compound. Activation of the coupling factor might, therefore, conceivably be regulated by both the level of energization and by electron transport per se (see McCarty and Carmeli, Chapter 14; Ort and Melandri, Chapter 12; and Junge and Jackson, Chapter 13, this volume). Vinkler (1981) has recently shown that limitation of photophosphorylation by low light (low electron transport rates) is accompanied by a decrease in the K_m^{app} for ADP, while limitation by uncouplers (high electron transport rates) is accompanied by an increase in K_m^{app} (ADP). Under a variety of conditions there was a strong, positive correlation between K_m^{app} (ADP) and the electron transport rate. Direct connections between coupling factors and the photosystems have been suggested but the evidence is poor (see Ort and Melandri, Chapter 12; Junge and Jackson, Chapter 13; and McCarty and Carmeli, Chapter 14, this volume). However, CF_1 is roughly stoichiometric with the number of electron transport chains (not photosystems).

In bacteria, activation of the ATPase is also observed although the characteristics vary somewhat with species. Tenuous evidence for a link with RCs in *Rp. sphaeroides* was provided by antibody labeling experiments on chromatophores (Reed *et al.*, 1975). In several species of the Rhodospirillaceae (facultative heterotrophs), ATPase activity is readily observable in chromatophores in the dark although it can be depressed by uncouplers and is stimulated by illumination. The enzyme is certainly less latent than that of chloroplasts. This could be consistent with the involvement in bacteria of the same ATPase in the energetics of several membrane functions including solute transport and respiration. In chloroplasts, on the other hand, photophosphorylation is the sole function of the thylakoid coupling factor (CF_1). An entirely separate ATPase in the chloroplast envelope maintains a small pH gradient between the stroma and the cytoplasm and may be involved in distributing sugars and phosphates (Douce and Joyard, 1975; Heber and Walker, 1979). It can be expected that this enzyme will have quite different regulatory properties from CF_1 .

VI. Structure and Organization of the Photosynthetic Apparatus

A. Molecular Organization

The first indication of a significant molecular superstructure in photosynthesis also came in the 1930s, with the discovery of the photosynthetic unit by Emerson and Arnold (1932). The process of excitation energy transfer that allows several hundred pigment molecules to cooperate as a light-harvesting antenna for a few RCs arises from excitonic coupling between nearby molecules and is now quite well understood (see Pearlstein, Chapter 7, this volume). The pigments of the photosynthetic unit are arranged to optimize the efficiency of energy transfer, which is dependent on both orientation and distance. Orientation of molecules can be studied by the use of polarized light as described by Breton and Vermeglio (Chapter 4, this volume). Experimentally, the methods are rather simple but interpretation is sometimes difficult. The primary source of complications is the excitonic interactions between neighboring molecules, generating transition moments that bear no simple relation to the original molecular axes. Nevertheless, a great deal of success has been had in determining the qualitative orientation of the light-harvesting and RC pigments of both plants and bacteria (Breton and Vermeglio, Chapter 4, this volume).

In principle, the relative orientations and distances of neighboring molecules can be obtained from analysis of the spectral perturbations caused by excitonic coupling, but this is only useful in simple and/or well-defined systems (Pearlstein, Chapter 7, this volume). The spectral perturbations, which include peak wavelength shifts, and narrowing and splitting of absorption bands, can be calculated for various model structures and several attempts have been made to account for the *in vivo* absorption spectra of Chl and BChl using exciton theory. It is now clear, however, that exciton interactions do not contribute significantly to the red shifts observed for these pigments *in vivo*, compared to their spectra in organic solvents (Pearlstein, Chapter 7, this volume). The *in vivo* red shifts of Chl and BChl are frequently considerable, i.e., 3100 cm^{-1} for BChl *b* in the light-harvesting pigment of *Rp. viridis*; 2600 cm^{-1} for BChl *b* in P960 (*Rp. viridis*); 1500 cm^{-1} for BChl *a* in P860; 900 cm^{-1} for Chl *a* in P700, and it is inescapable that it is, in fact, the protein that is responsible for the spectral characteristics although *not* via simple solvatochromism. The existence of many different spectral forms of Chl *in vivo* has been recognized since the 1920s and even then was ascribed to the presence of Chl-protein complexes (Lévy *et al.*, 1925; Lubimenko, 1927)!

The wide range of peak absorption wavelengths of the different visual pigments (rhodopsins) has been neatly accounted for by the effect of *charged* amino acid groups near the retinal chromophore (Honig *et al.*, 1979). Even with a single charge, peak shifts of almost any size and direction can be obtained depending on the geometry, and in order to constrain the theory, elegant experimentation with retinal analogs was used (Arnaboldi *et al.*, 1979; Sheves *et al.*, 1979). The electronic structure of Chls and derivatives is now fairly well understood and both singlet and triplet manifolds are described by Shipman (Chapter 6, this volume). Theory is clearly adequate to the task of deriving the spectral influences of nearby charges on the Chls but, experimentally, the problem of substituting known Chl analogs into the pigment complexes seems to be quite beyond us. Boxer has initiated some elegant studies with chlorophyll-(ide) incorporated into apomyoglobin (Boxer and Wright, 1979) but the spectral shifts appear to be minimal, consistent with the hydrophobic nature of the heme pocket. There has been one claim of exchanging the BChls of a bacterial RC for deuterated ones (Loach *et al.*, 1975). If this can be confirmed it would provide an extremely important experimental tool for studying the spectral and photochemical properties of RCs.

Actually the influence of charges and local electric fields on the spectral properties of photosynthetic pigments has long been known. The

sensitivity and linearity of the electrochromic response of the carotenoids to electric fields across and within the membrane, indicate that these molecules are under the influence of a large ($\geq 2 \times 10^6$ V cm⁻¹) permanent electric field (Junge, 1977; Wraight *et al.*, 1978; Junge and Jackson, Chapter 13, this volume). Only a fraction of the total carotenoid population (in bacteria it is those associated with the B800/850 light-harvesting pigment complex) participates in the electrochromic effect and this population is significantly red-shifted by comparison with the rest (Amesz and de Grooth, 1976; de Grooth and Amesz, 1977; Symons *et al.*, 1977). It has been suggested that the permanent field might be provided by the Mg²⁺ of an associated Chl or BChl (Sewe and Reich, 1977). Although their specific model is not appropriate, because it involves hydroxyl substituents absent from many *in vivo* carotenoids, the general idea is a valid possibility and is consistent with a blue shift in the carotenoid spectrum that occurs when the Chl is pheophytinized (Okada and Takamiya, 1970). A theoretical analysis of the *in vivo* carotenoid spectra, along the lines of Honig's theory for the visual pigments, has been started (Kakitani *et al.*, 1981) and should be experimentally accessible as the carotenoids can be rather easily extracted and specifically reconstituted (Boucher *et al.*, 1977; Davidson and Cogdell, 1981).

B. Membrane Structure

At the supramolecular level, structural information is available from electron microscopy. In contrast to the molecular level, distance rather than orientation parameters are the most easily determined. Freeze fracture electron microscopic studies, in particular, have provided a quite detailed picture of the chloroplast thylakoid, and dynamic and developmental properties have also been elucidated (Kaplan and Arntzen, Chapter 3, this volume). Lateral movement of membrane complexes occurs quite readily in chloroplast membranes and the heterogeneous distribution of PSI and PSII has been described (Section V,C; I. Ohad and G. Drews, Chapter 5, in Govindjee, 1982; and Kaplan and Arntzen, Chapter 3, this volume). Such mobility is consistent with the average thylakoid membrane protein : lipid ratio of about 1, relatively low for a highly functional membrane. In bacteria this ratio is considerably higher, varying from 2 to 5 throughout the cell division cycle, and it is probable that lateral mobility of membrane proteins would be somewhat restricted, at least at the higher ratios. X-Ray scattering studies on *Rs. rubrum* have, in fact, shown a fairly high degree of order (hexagonal packing) in the plane of the membrane (Ueki *et al.*, 1976).

The photosynthetic membranes (intracytoplasmic membranes) of the

purple bacteria are extremely diverse morphologically, forming vesicles, thylakoids, and tubules in different species. The green sulfur bacteria have a very distinctive and rather uniform internal structure that has been described in detail (Olson, 1980; Staehelin *et al.*, 1980). They are characterized by large internal vesicles called chlorosomes. These have nonunit membranes, probably a glycolipid/proteolipid structure, and contain only light-harvesting pigments (BChls *c*, *d*, and *e*) which are present in long, polymeric protein tubules. The chlorosomes are arranged peripherally and abut the cell membrane, which contains the active components of the photosynthetic apparatus. The bottom of the chlorosome ("baseplate"), in contact with the cell membrane, is a paracrystalline array of BChl *a* protein and serves to connect the chlorosome to several RCs in the cell membrane.

The cyanobacteria are also rather homogeneous in membrane morphology. All species, except one, contain several concentric thylakoid lamellae of uniform dimensions. They are separated only by the thickness of the phycobilisomes which are arrayed on the thylakoid membrane surface. In the one exception, *Gloeocapsa*, photosynthetic activity resides in the cell membrane, with phycobilisomes on the inner surface. The general uniformity of internal structures in the cyanobacteria is in marked contrast with the wide variety of cellular morphology and their apparent genetic diversity. The group is extremely diverse in DNA base content (GC content = 35–71%; Herdman *et al.*, 1979a) and genome size ($2-9 \times 10^9$; Herdman *et al.*, 1979b). However, analysis of 16 S rRNA has not shown a comparable range of oligonucleotide patterns, but it is noteworthy that no high GC strains have been analyzed yet (Fox *et al.*, 1980; see V. A. Saunders and D. E. Buetow, Chapters 2–4, in Govindjee, Vol. II, 1982).

VII. Phylogenetic and Metabolic Comparisons in Photosynthesis

The endosymbiotic origin of several eukaryotic organelles, especially chloroplasts, is well supported by morphological and biochemical comparisons (Whatley *et al.*, 1979), and there are also many astonishingly close parallels in the biophysical chemistry of plant and bacterial photosynthesis. Several examples are known of unicellular eukaryotes with endosymbiotic cyanobacteria still recognizable as such by, e.g., vestigial cell wall structures (Trench *et al.*, 1978; Kremer *et al.*, 1979). In situ, the endosymbiotic cyanobacteria are termed *cyanelles*. In the case of *Cyanophora paradoxa*, the relationship between the host and the endosym-

biont, *Cyanocyta korschikoffiana*, involves significant transport and metabolic interplay between the two organisms and the association is obligate (Trench and Siebens, 1978; Trench *et al.*, 1978). The high degree of integration is apparent from the exceptionally small genome of the cyanelle ($\sim 10^8$) which is close to that of chloroplasts and not more than 5% that of free living cyanobacteria (Herdman and Stanier, 1977).

Endosymbiosis of cyanobacteria is considered a likely origin for chloroplasts in the Rhodophyta (red algae) and a close relationship is apparent from 16 S rRNA analysis (Fox *et al.*, 1980). The origin of chloroplasts in the Chlorophyta and higher plants, however, has been more problematical because of their characteristic content of Chl *b* which is conspicuously absent from the cyanobacteria and Rhodophyta. The discovery of a prokaryotic organism containing Chl *b* and lacking phycobilisomes was, therefore, very welcome (Lewin and Withers, 1975; Lewin, 1976; Thorne *et al.*, 1977). [Although provisionally classified in a new *algal* division, the Prochlorophyta (Lewin, 1976), some argument can be made that a bacterial nomenclature would be more rational.] The genus described, *Prochloron*, has not only the appropriate pigment composition but also displays appression of thylakoids and formation of rudimentary thylakoid stacks (Whatley, 1977). Presently, the only characterized species of this new phylum, *Prochloron didemni*, exists as an ectosymbiont (possibly obligate) residing in apparently specialized grooves and cavities within the ascidian host (*Didemnum*, a sea squirt).

The remaining order of eukaryotic photosynthetic organisms, the Chromophyta, are more diverse including both Chl *c* and *d* containing algae and the Chl *b*-containing Euglenophyceae. There is reasonable support for the suggestion that they arose from possibly several occurrences of endosymbiosis between two or even more eukaryotic organisms; a present day example of this is *Mesodinium* (Whatley *et al.*, 1979).

The endosymbiotic origin of mitochondria is also well supported by present day examples. The giant ameba, *Pelomyxa palustris* lacks mitochondria but has two endosymbiotic bacterial species. One of these is especially well integrated into the host life cycle and seems to function much as a mitochondrion (Whatley, 1976). On the basis of 16 S rRNA homology, the most likely candidates for the mitochondrial precursor bacterium are from the ancestral line of the Rhodospirillaceae and their close relatives (Gibson *et al.*, 1979). Hydrogenosomes in certain anaerobic flagellates have also been suggested as arising by endosymbiosis. These microbody-like organelles serve to remove excess reducing power as H_2 gas and there is some indication that they arose from a chlostridial-type endosymbiont (Müller, 1975; Whatley *et al.*, 1979).

Clearly there are indications of many independent endosymbiotic ori-

gins for eukaryotic organelles and possibly several just for chloroplasts. The question remains, however, as to how oxygenic photosynthesis itself arose. The biophysical relationships described in this chapter and throughout this volume and Volume II (Govindjee, 1982), may be of some importance in understanding this step, although at the moment there are obviously crucial pieces of information still missing. Gaps in our knowledge are especially evident for the green bacteria. Further characterization of the electron acceptors is needed to determine the relationship, if any, with PSI. A remarkable physiological parallel has recently been demonstrated in that several species of cyanobacteria are capable of anoxygenic photosynthesis, using sulfide as electron donor and involving only PSI (Cohen *et al.*, 1975; Garlick *et al.*, 1977). The Cyt complexes of green bacteria are also poorly characterized as yet. A low potential Cyt *b* ($E_{m,7} \sim -0.14$ V) and a Rieske-type Fe-S center ($E_{m,7} \sim +0.16$ V) have been described, providing the possible nucleus of a Cyt *b-c*₁ complex. An interesting correlation between the green photosynthetic bacteria and the cyanobacteria is that both groups have extensive extra-membrane light-harvesting structures—chlorosomes in the Chlorobiineae and phycobilisomes in the cyanobacteria. Studies on *Chloroflexus* by R. C. Fuller (personal communication) had indicated that the chlorosomes of this species may not be bounded by a proteolipid membrane, unlike those of the Chlorobiaceae. Thus, the relationship with the cyanobacteria, in which the phycobilisomes are also unbounded, may be stronger for the Chloroflexaceae.

Respiration in the cyanobacteria is usually of very low activity and is rather weakly inhibited by cyanide but is sensitive to CO (Stanier and Cohen-Bazire, 1977), indicating a *b*- or *o*-type Cyt as the terminal oxidase. Almost all species are obligate phototrophs and many are obligate autotrophs. Those that can grow photoheterotrophically do so only with a very limited range of substrates, mostly mono- or disaccharides. The primary reason for this limitation is the absence, throughout the division, of α -ketoglutarate dehydrogenase (Stanier and Cohen-Bazire, 1977). The function of the remaining citrate cycle enzymes is, therefore, strictly anabolic. The absence of α -ketoglutarate dehydrogenase is common among obligate autotrophs (Smith *et al.*, 1967). However, this deficiency has not been established for the obligately photoautotrophic green sulfur bacteria (Chlorobiaceae) and it may arise in many autotrophs principally as a secondary loss rather than a primitive condition. The gliding, filamentous, green photosynthetic bacteria (Chloroflexaceae) are facultative chemoheterotrophs with very broad substrate specificity. They presumably have an intact citrate cycle. The green bacteria share certain unusual lipid components, including sulfoquinovosyl

diglyceride, with the cyanobacteria and other oxygenic photosynthetic organisms (Kenyon, 1978). The division between the Chloroflexaceae and Chlorobiaceae, determined from 16 S rRNA analysis, is very deep (Fox *et al.*, 1980), even though their internal structures appear similar. The properties of the RC in *Chloroflexus* also support a very significant distinction between these two groups. The apparently hybrid nature of *Chloroflexus* raises the possibility of an evolutionary position intermediate between the ancient green sulfur bacteria and the more recent groups, providing antecedents to both the purple bacteria and the oxygenic photosynthetic organisms.

Oxidative metabolism in the cyanobacteria occurs exclusively through the pentose phosphate pathway, yielding NADPH (Stanier and Cohen-Bazire, 1977). The function of NADPH in both photosynthetic and respiratory capacities suggests the activity of a single electron transport chain in both processes, and attempts to show separate membrane locations for these functions have failed so far. In this and other respects the cyanobacteria are similar to the purple nonsulfur bacteria in which the same Cyt *b-c*₁ complex and Cyt *c*₂ are active in photosynthetic and respiratory electron transport (Baccarini-Melandri *et al.*, 1978; Zannoni *et al.*, 1980). Furthermore, in several species of the Rhodospirillaceae, the terminal oxidase is a high potential Cyt *b* with limited sensitivity to cyanide (Smith and Pinder, 1978; Zannoni *et al.*, 1978).

In addition to these suggestive parallels, a very close homology has been described here between the acceptor quinone complexes of PSII and the purple photosynthetic bacteria, and it is clear that evolutionary connections to oxygenic photosynthesis can be argued for both purple and green bacteria. It is of interest to note that genome sizes throughout the Eubacteria (except for *Mycoplasma*) fall into clusters that represent multiples of a minimum size of about 1.2×10^9 (Bak *et al.*, 1970). In the cyanobacteria, genome sizes also vary in discrete steps but the lowest multiple is twice this minimum unit (Herdman *et al.*, 1979b). It seems possible that an initial genome doubling may have been a prerequisite for the development of two photosystems in oxygenic photosynthesis.

VIII. Concluding Remarks

The discovery, in the last decade, of two entirely new photosynthetic, prokaryote divisions—the Chloroflexaceae, as facultative, aerobic counterparts to the Chlorobiaceae, and the Chl *b*-containing prokaryote *Prochloron*—is still too recent for many significant details of their biophysical and biochemical characteristics to be available. This is, therefore, a

rather inopportune moment to review the comparative aspects of photosynthesis, for future studies of these organisms will surely fill many significant gaps in our understanding of the evolution of photosynthesis and of bioenergetics in general. Nevertheless, the parallels between bacterial and plant photosynthesis as discussed here are often striking. Figure 1 summarizes the notable features of the electron transport system and emphasizes the molecular counterparts currently recognized in plants and photosynthetic bacteria.

It is noteworthy that although 16 S rRNA analyses show a clear relationship between the cyanobacteria and the chloroplasts of Rhodophyta, this is not the case for the higher plants. Indeed, the Chlorophyte and higher plant chloroplast appears to be barely more closely related to the cyanobacteria than it is to the Rhodospirillineae (Gibson *et al.*, 1979; Fox *et al.*, 1980). An early split between the two oxygenic photosynthetic groups is, therefore, indicated. Unfortunately, in the absence of any such data from the new Chl *b*-containing prokaryotes and the scanty rRNA data from the green bacteria in general, it is impossible to construct, with any confidence, an evolutionary tree for photosynthetic organisms as a whole.

REFERENCES

- Amesz, J., and de Grooth, B. G. (1976). *Biochim. Biophys. Acta* **440**, 301–313.
- Anderson, J. M. (1981). *FEBS Lett.* **124**, 1–10.
- Andersson, B., and Anderson, J. M. (1980). *Biochim. Biophys. Acta* **593**, 427–440.
- Arnaboldi, M., Molto, M. G., Tsujimoto, K., Balogh-Nair, V., and Nakanishi, K. (1979). *J. Am. Chem. Soc.* **101**, 7082–7084.
- Ausländer, W., and Junge, W. (1974). *Biochim. Biophys. Acta* **357**, 285–298.
- Baccarini-Melandri, A., Jones, O. T. G., and Hauska, G. (1978). *FEBS Lett.* **86**, 151–154.
- Bak, A. L., Christiansen, C., and Stenderup, A. (1970). *J. Gen. Microbiol.* **64**, 377–380.
- Bamberger, E. S., Rottenberg, H., and Avron, M. (1973). *Eur. J. Biochem.* **34**, 557–563.
- Barouch, Y., and Clayton, R. K. (1977). *Biochim. Biophys. Acta* **462**, 785–788.
- Bartsch, R. G. (1978). In "The Photosynthetic Bacteria" (R. K. Clayton and W. R. Sistrom, eds.), Chapter 13, pp. 249–279. Plenum, New York.
- Bashford, C. L., Baltscheffsky, M., and Prince, R. C. (1979). *FEBS Lett.* **97**, 55–60.
- Bazzaz, M. B. (1980). *Fed. Proc.* **39**, 1802a.
- Bazzaz, M. B. (1981a). *Photobiochem. Photobiophys.* **2**, 199–207.
- Bazzaz, M. B. (1981b). *Naturwiss.* **68**, 94.
- Bazzaz, M. B., and Brereton, R. G. (1982). *FEBS Lett.* **138**, 104–108.
- Bazzaz, M. B., Bradley, C. V., and Brereton, R. G. (1982). *Tetrahedron Lett.* **23**, 1211–1214.
- Bélangier, F. C., and Rebeiz, C. A. (1979). *Biochem. Biophys. Res. Commun.* **88**, 365–372.
- Berg, S. P., Luszczakoski, D. M., and Morse, P. D. (1979). *Arch. Biochem. Biophys.* **194**, 138–148.
- Bishop, N. I. (1959). *Proc. Natl. Acad. Sci. U.S.A.* **45**, 1696–1702.

- Blankenship, R. E., Schaafsma, T. J., and Parson, W. W. (1977). *Biochim. Biophys. Acta* **461**, 297–305.
- Bolton, J. R. (1977). In "Primary Processes of Photosynthesis" (J. Barber, ed.), Chapter 5, pp. 187–202. Elsevier, Amsterdam.
- Boso, B., Debrunner, P., Okamura, M. Y., and Feher, G. (1981). *Biochim. Biophys. Acta* **638**, 173–177.
- Boucher, F., van der Rest, M., and Gingras, G. (1977). *Biochim. Biophys. Acta* **469**, 339–357.
- Bouges-Bocquet, B. (1973). *Biochim. Biophys. Acta* **314**, 250–256.
- Bouges-Bocquet, B. (1977). *Biochim. Biophys. Acta* **462**, 371–379.
- Bouges-Bocquet, B. (1978a). *FEBS Lett.* **85**, 340–344.
- Bouges-Bocquet, B. (1978b). *FEBS Lett.* **94**, 95–99.
- Bouges-Bocquet, B. (1980). *Biochim. Biophys. Acta* **590**, 223–233.
- Bouges-Bocquet, B. (1981). *Proc. Int. Congr. Photosynth.* **5th**, 1980, Abstract 82.
- Bowes, J. M., Horton, P., and Bendall, D. S. (1981). *FEBS Lett.* **135**, 261–264.
- Bowyer, J. R. (1980). Ph.D. Thesis, Bristol University, U.K.
- Bowyer, J. R., Baccarini-Melandri, A., Melandri, B. A., and Crofts, A. R. (1978). *Z. Naturforsch., C: Biosci.* **33C**, 704–711.
- Bowyer, J. R., Dutton, P. L., Prince, R. C., and Crofts, A. R. (1980). *Biochim. Biophys. Acta* **592**, 445–460.
- Boxer, S. G., and Wright, K. A. (1979). *J. Am. Chem. Soc.* **101**, 6791–6794.
- Butler, W. F., Johnston, D. C., Shore, H. B., Fredkin, D. R., Okamura, M. Y., and Feher, G. (1980). *Biophys. J.* **32**, 967–992.
- Clayton, R. K. (1981). "Photosynthesis: Physical Mechanisms and Chemical Patterns," IUPAB Biophys. Ser. Cambridge Univ. Press, London and New York.
- Cogdell, R. J., Monger, T. G., and Parson, W. W. (1975). *Biochim. Biophys. Acta* **408**, 189–199.
- Cohen, Y., Jørgenson, B. B., Padan, E., and Shilo, M. (1975). *Nature (London)* **257**, 489–492.
- Cramer, W. A., and Butler, W. L. (1969). *Biochim. Biophys. Acta* **172**, 503–510.
- Cramer, W. A., and Whitmarsh, J. (1977). *Annu. Rev. Plant Physiol.* **28**, 133–172.
- Crofts, A. R., and Bowyer, J. R. (1980). *Ann. N.Y. Acad. Sci.* **341**, 12–26.
- Crofts, A. R., and Meinhardt, S. W. (1982). *Biochem. Soc. Trans.* (in press).
- Crofts, A. R., Meinhardt, S. W., and Bowyer, J. R. (1982). In "Function of Quinones in Energy Coupling Systems" (B. L. Trumpower, ed.). Academic Press, New York (in press).
- Crowther, D., and Hind, G. (1980). *Arch. Biochem. Biophys.* **204**, 568–577.
- Crowther, D., Mills, J. D., and Hind, G. (1979). *FEBS Lett.* **98**, 386–390.
- Davidson, E., and Cogdell, R. J. (1981). *Biochim. Biophys. Acta* **635**, 295–303.
- Davis, M. S., Forman, A., and Fajer, J. (1979). *Proc. Natl. Acad. Sci. U.S.A.* **76**, 4170–4174.
- deGroot, B. G., and Ames, J. (1977). *Biochim. Biophys. Acta* **462**, 247–258.
- deGroot, B. G., van Grondelle, R., Romijn, J. C., and Pulles, M. P. J. (1978). *Biochim. Biophys. Acta* **503**, 480–490.
- deVries, S., Albracht, S. P. J., and Leeuwerik, F. J. (1979). *Biochim. Biophys. Acta* **546**, 316–333.
- deVries, S., Berden, J. A., and Slater, E. C. (1980). *FEBS Lett.* **122**, 143–148.
- Dickerson, R. E. (1980). *Sci. Am.* **242**, 130–154.
- Dilley, R. A., and Giaquinta, R. T. (1975). *Curr. Top. Membr. Transp.* **7**, 49–107.
- Diner, B. A. (1977). *Biochim. Biophys. Acta* **460**, 247–258.
- Douce, R., and Joyard, J. (1975). *FEBS Lett.* **51**, 335–340.
- Dutton, P. L., and Prince, R. C. (1978). In "The Photosynthetic Bacteria" (R. K. Clayton and W. R. Sistrom, eds.), Chapter 28, pp. 525–570. Plenum, New York.

- Dutton, P. L., and Wilson, D. F. (1974). *Biochim. Biophys. Acta* **346**, 165–212.
- Dutton, P. L., Leigh, J. S., and Seibert, M. (1972). *Biochem. Biophys. Res. Commun.* **46**, 406–413.
- Dutton, P. L., Leigh, J. S., and Wraight, C. A. (1973). *FEBS Lett.* **36**, 169–173.
- Ellefson, W. L., Ulrich, E. A., and Krogmann, D. W. (1980). In "Methods in Enzymology" (A. San Pietro, ed.), Vol. 69, pp. 223–228. Academic Press, New York.
- Ellsworth, R. K., and Aronoff, S. (1969). *Arch. Biochem. Biophys.* **130**, 374–383.
- Emerson, R., and Arnold, W. (1932). *J. Gen. Physiol.* **16**, 191–205.
- Fajer, J., Davis, M. S., Brune, D. C., Spaulding, L. D., Borg, D. C., and Forman, A. (1976). *Brookhaven Symp. Biol.* **28**, 74–104.
- Fajer, J., Davis, M. S., Forman, A., Klimov, V. V., Dolan, E., and Ke, B. (1980). *J. Am. Chem. Soc.* **102**, 7143–7145.
- Fehér, G., Okamura, M. Y., and McElroy, J. D. (1972). *Biochim. Biophys. Acta* **267**, 222–226.
- Fenton, J. M., Pellin, M. J., Govindjee, and Kaufmann, K. J. (1979). *FEBS Lett.* **100**, 1–4.
- Fox, G. E., Stackebrandt, E., Hespell, R. B., Gibson, J., Maniloff, J., Dyer, T. A., Wolfe, R. S., Balch, W. E., Tanner, R. S., Magnum, L. J., Zablén, L. B., Blakemore, R., Gupta, R., Bonen, L., Lewis, B. J., Stahl, D. A., Leuhrsen, K. R., Chen, K. N., and Woese, C. R. (1980). *Science* **209**, 457–463.
- Frank, H. A., McLean, M. B., and Sauer, K. (1979). *Proc. Natl. Acad. Sci. U.S.A.* **76**, 5124–5128.
- Freyssinet, G., Rebeiz, C. A., Fenton, J. F., Khanna, R., and Govindjee, (1980). *Photobiochem. Photobiophys.* **1**, 203–212.
- Futami, A., Hurt, E., and Hauska, G. (1979). *Biochim. Biophys. Acta* **547**, 583–596.
- Gaffron, H. (1934). *Biochem. Z.* **269**, 447–455.
- Gaffron, H. (1942). *J. Gen. Physiol.* **26**, 241–267.
- Garlick, S., Oren, A., and Padan, E. (1977). *J. Bacteriol.* **129**, 623–629.
- Gibson, J., Stackebrandt, E., Zablén, L. B., Gupta, R., and Woese, C. R. (1979). *Curr. Microbiol.* **3**, 59–64.
- Govindjee, ed. (1975). "Bioenergetics of Photosynthesis." Academic Press, New York.
- Govindjee, ed. (1982). "Photosynthesis: Development, Carbon Metabolism, and Plant Productivity," Vol. II. Academic Press, New York.
- Graan, T., Flores, S., and Ort, D. R. (1981). In "Photosynthetic Energy Transduction" (B. Selman, ed.), Am. Elsevier, New York, pp. 25–34.
- Haehnel, W. (1976). *Biochim. Biophys. Acta* **440**, 506–521.
- Haehnel, W., Pröpper, A., and Krause, H. (1980a). *Biochim. Biophys. Acta* **593**, 384–399.
- Haehnel, W., Hesse, V., and Pröpper, A. (1980b). *FEBS Lett.* **111**, 79–82.
- Heber, U., and Walker, D. A. (1979). *Trends Biochem. Sci.* **4**, 252–256.
- Herdman, M., and Stanier, R. Y. (1977). *FEMS Lett.* **1**, 7–12.
- Herdman, M., Janvier, M., Waterbury, J. B., Rippka, R., and Stanier, R. Y. (1979a). *J. Gen. Microbiol.* **111**, 63–71.
- Herdman, M., Janvier, M., Rippka, R., and Stanier, R. Y. (1979b). *J. Gen. Microbiol.* **111**, 73–85.
- Hoff, A. J. (1976). *Biochim. Biophys. Acta* **440**, 765–771.
- Hoff, A. J., Rademaker, H., van Grondelle, R., and Duysens, L. N. M. (1977). *Biochim. Biophys. Acta* **460**, 547–554.
- Honig, B., Dinur, V., Nakinishi, K., Balogh-Nair, V., Gawinowicz, M. A., Arnaboldi, M., and Motto, M. G. (1979). *J. Am. Chem. Soc.* **101**, 7084–7086.
- Hope, A. B., and Moreland, A. (1979). *Aust. J. Plant Physiol.* **6**, 289–304.
- Horton, P., and Croze, E. (1979). *Biochim. Biophys. Acta* **545**, 188–201.
- Horton, P., and Naylor, B. (1979). *Photobiochem. Photobiophys.* **1**, 17–23.
- Hurt, E., and Hauska, G. (1981). *Eur. J. Biochem.* **37**, 1–9.

- Jennings, J. V., and Evans, M. C. W. (1977). *FEBS Lett.* **75**, 33–36.
- Joliot, P., and Joliot, A. (1979). *Biochim. Biophys. Acta* **646**, 93–105.
- Jones, O. T. G. (1963). *Biochem. J.* **89**, 182–189.
- Junge, W. (1977). *Annu. Rev. Plant Physiol.* **28**, 503–536.
- Jursinic, P., and Govindjee (1977). *Photochem. Photobiol.* **26**, 617–628.
- Kakitani, T., Honig, B., and Crofts, A. R. (1981). *Biophys. J.* **39**, 57–63.
- Katz, J. J., Norris, J. R., Shipman, L. L., Thurnauer, M. C., and Wasielewski, M. R. (1978). *Annu. Rev. Biophys. Bioeng.* **7**, 393–434.
- Kell, D. B. (1979). *Biochim. Biophys. Acta* **549**, 55–99.
- Kell, D. B., Ferguson, S. J., and John, P. (1978). *Biochim. Biophys. Acta* **502**, 111–126.
- Kenyon, C. N. (1978). In "The Photosynthetic Bacteria" (R. K. Clayton and W. R. Sistrom, eds.), Chapter 14, pp. 281–313. Plenum, New York.
- Klimov, V. V., Dolan, E., and Ke, B. (1980a). *FEBS Lett.* **112**, 97–100.
- Klimov, V. V., Dolan, E., Shaw, E. R., and Ke, B. (1980b). *Proc. Natl. Acad. Sci. U.S.A.* **77**, 7227–7231.
- Knaff, D. B. (1975). *FEBS Lett.* **60**, 331–335.
- Knaff, D. B. (1978). In "The Photosynthetic Bacteria" (R. K. Clayton and W. R. Sistrom, eds.), Chapter 32, pp. 629–640. Plenum, New York.
- Kremer, B. P., Kies, L., and Rostami-Rabet, A. (1979). *Z. Pflanzenphysiol.* **92**, 303–317.
- Leigh, J. S., and Dutton, P. L. (1974). *Biochim. Biophys. Acta* **357**, 67–77.
- Levanon, H., and Norris, J. R. (1978). *Chem. Rev.* **78**, 185–198.
- Lévy, R., Teissier, G., and Wurmser, R. (1925). *Ann. Physiol. Physicochim. Biol.* **1**, 298–311.
- Lewin, R. A. (1976). *Nature (London)* **261**, 697–698.
- Lewin, R. A., and Withers, N. W. (1975). *Nature (London)* **256**, 735–757.
- Loach, P. A., Kung, M., and Hales, B. J. (1975). *Ann. N.Y. Acad. Sci.* **244**, 297–318.
- Lubimenko, V. (1927). *Rev. Gen. Bot.* **39**, 619–637.
- Matsuura, K., and Dutton, P. L. (1981). In "Chemiosmotic Proton Circuits in Biological Membranes" (V. P. Skulachev and P. C. Hinkle, eds.), pp. 259–270. Addison-Wesley, New York.
- Matsuura, K., Packham, N. K., Mueller, P., and Dutton, P. L. (1981). *FEBS Lett.* **131**, 17–22.
- Metzner, H. (1975). *J. Theor. Biol.* **51**, 201–231.
- Mitchell, P. (1966). "Chemiosmotic Coupling in Oxidative and Photosynthetic Phosphorylation." Glynn Res., Bodmin, Cornwall, England.
- Mitchell, P. (1975). *FEBS Lett.* **56**, 1–6.
- Mitchell, P. (1976). *J. Theor. Biol.* **62**, 327–367.
- Mitchell, P. (1979). *Science* **206**, 1148–1159.
- Mitchell, P. (1982). In "Function of Quinones in Energy Coupling Systems" (B. L. Trumpower, ed.). Academic Press, New York (in press).
- Müller, M. (1975). *Annu. Rev. Microbiol.* **29**, 467–483.
- Nelson, N., and Neumann, J. (1968). *Biochem. Biophys. Res. Commun.* **30**, 142–147.
- Norris, J. R., and Katz, J. J. (1978). In "The Photosynthetic Bacteria" (R. K. Clayton and W. R. Sistrom, eds.), Chapter 21, pp. 397–418. Plenum, New York.
- Nugent, J. H. A., Diner, B. A., and Evans, M. C. W. (1981). *FEBS Lett.* **124**, 241–244.
- Ohnishi, T., and Trumpower, B. L. (1980). *J. Biol. Chem.* **255**, 3278–3284.
- Okada, M., and Takamiya, A. (1970). *Plant Cell Physiol.* **11**, 713–721.
- Okamura, M. Y., Isaacson, R. A., and Feher, G. (1975). *Proc. Natl. Acad. Sci. U.S.A.* **72**, 3491–3495.
- O'Keefe, D. P., and Dutton, P. L. (1981). *Biochim. Biophys. Acta* **635**, 149–166.
- O'Keefe, D. P., Prince, R. C., and Dutton, P. L. (1981). *Biochim. Biophys. Acta* **637**, 512–522.

- Olsen, L. F., Telfer, A., and Barber, J. (1980). *FEBS Lett.* **118**, 11–17.
- Olson, J. M. (1980). *Biochim. Biophys. Acta* **594**, 93–51.
- Olson, J. M., Prince, R. C., and Brune, D. C. (1976). *Brookhaven Symp. Biol.* **28**, 238–245.
- Ort, D. R., Dilley, R. A., and Good, N. (1976). *Biochim. Biophys. Acta* **449**, 108–124.
- Overfield, R. E., and Wraight, C. A. (1980a). *Biochemistry* **19**, 3322–3327.
- Overfield, R. E., and Wraight, C. A. (1980b). *Biochemistry* **19**, 3328–3334.
- Overfield, R. E., Wraight, C. A., and DeVault, D. (1979). *FEBS Lett.* **105**, 137–142.
- Packham, N. K., Tiede, D. M., Mueller, P., and Dutton, P. L. (1980). *Proc. Natl. Acad. Sci. U.S.A.* **77**, 6339–6343.
- Papahadjopoulos, D. (1972). *Biochim. Biophys. Acta* **268**, 169–186.
- Petty, K. M., and Dutton, P. L. (1976). *Arch. Biochem. Biophys.* **172**, 335–345.
- Petty, K. M., Jackson, J. B., and Dutton, P. L. (1979). *Biochim. Biophys. Acta* **546**, 17–42.
- Pfennig, N. (1977). *Annu. Rev. Microbiol.* **31**, 275–290.
- Pierson, B. K., and Castenholz, R. W. (1974). *Arch. Mikrobiol.* **100**, 283–305.
- Prince, R. C., and Dutton, P. L. (1975). *Biochim. Biophys. Acta* **387**, 609–613.
- Prince, R. C., and Dutton, P. L. (1976). *Arch. Biochem. Biophys.* **172**, 329–334.
- Prince, R. C., and Dutton, P. L. (1977). *Biochim. Biophys. Acta* **462**, 731–747.
- Prince, R. C., and Dutton, P. L. (1978). In "The Photosynthetic Bacteria" (R. K. Clayton and W. R. Sistrom, eds.), Chapter 24, pp. 439–453. Plenum, New York.
- Prince, R. C., and Olson, J. M. (1976). *Biochim. Biophys. Acta* **423**, 357–362.
- Prince, R. C., Leigh, J. S., and Dutton, P. L. (1976). *Biochim. Biophys. Acta* **440**, 622–636.
- Rabinowitch, E. I. (1945). "Photosynthesis and Related Processes," Vol. I. Wiley (Interscience), New York.
- Rademaker, H., Hoff, A. J., and Duysens, L. N. M. (1979). *Biochim. Biophys. Acta* **546**, 248–255.
- Rebeiz, C. A., Bélanger, F. C., Freyssinet, G., and Saab, D. G. (1980). *Biochim. Biophys. Acta* **590**, 234–247.
- Reed, D. W., Raveed, D., and Reporter, M. (1975). *Biochim. Biophys. Acta* **387**, 368–378.
- Renger, G., Gläser, M., and Buchwald, H. E. (1976). *Biochim. Biophys. Acta* **461**, 392–402.
- Rich, P. R., and Bendall, D. S. (1980). *Biochim. Biophys. Acta* **591**, 153–161.
- Rosen, D., Okamura, M. Y., and Feher, G. (1980). *Biochemistry* **19**, 5687–5692.
- Rottenberg, H. (1979). *Biochim. Biophys. Acta* **549**, 279–353.
- Ruben, S., Randall, M., Kamen, M., and Hyde, J. L. (1941). *J. Am. Chem. Soc.* **63**, 877–879.
- Rutherford, A. W. (1981). *Biochem. Biophys. Res. Commun.* **102**, 1065–1070.
- Rutherford, A. W., and Mullet, J. E. (1981). *Biochim. Biophys. Acta* **635**, 225–235.
- Rutherford, A. W., Heathcote, P., and Evans, M. C. W. (1979). *Biochim. J.* **182**, 515–523.
- Rutherford, A. W., Mullet, J. E., and Crofts, A. R. (1981a). *FEBS Lett.* **123**, 235–237.
- Rutherford, A. W., Paterson, D. R., and Mullet, J. E. (1981b). *Biochim. Biophys. Acta* **635**, 205–214.
- Saphon, S., and Crofts, A. R. (1977). *Z. Naturforsch., C: Biosci.* **32C**, 810–816.
- Sewe, K.-V., and Reich, R. (1977). *Z. Naturforsch., C: Biosci.* **32C**, 161–171.
- Sheves, M., Nakanishi, K., and Honig, B. (1979). *J. Am. Chem. Soc.* **101**, 7086–7088.
- Shin, H., and Oshino, R. (1978). *J. Biochem. (Tokyo)* **83**, 357–361.
- Shipman, L. L., Cotton, T. M., Norris, J. R., and Katz, J. J. (1976). *Proc. Natl. Acad. Sci. U.S.A.* **73**, 1791–1794.
- Shuvalov, V. A., Krakhmaleva, I. N., and Klimov, V. V. (1976). *Biochim. Biophys. Acta* **449**, 597–801.
- Shuvalov, V. A., Dolan, E., and Ke, B. (1979a). *Proc. Natl. Acad. Sci. U.S.A.* **76**, 770–773.
- Shuvalov, V. A., Klevanik, A. V., Sharkov, A. V., Kryukov, P. G., and Ke, B. (1979b). *FEBS Lett.* **107**, 313–316.

- Shuvalov, V. A., Klimov, V. V., Dolan, E., Parson, W. W., and Ke, B. (1980). *FEBS Lett.* **118**, 279–282.
- Smith, A. J., London, J., and Stanier, R. Y. (1967). *J. Bacteriol.* **94**, 972–983.
- Smith, L., and Pinder, P. B. (1978). In "The Photosynthetic Bacteria" (R. K. Clayton and W. R. Sistrom, eds.), Chapter 33, pp. 641–654. Plenum, New York.
- Staehelein, L. A., Golecki, J. R., and Drews, G. (1980). *Biochim. Biophys. Acta* **589**, 30–45.
- Stanier, R. Y., and Cohen-Bazire, G. (1977). *Annu. Rev. Microbiol.* **31**, 225–274.
- Stemler, A., and Radmer, R. (1975). *Science* **190**, 457–458.
- Stöhl, A. (1932). *Naturwissenschaften* **20**, 955–958.
- Swarthoff, T., and Amesz, J. (1979). *Biochim. Biophys. Acta* **548**, 427–432.
- Swarthoff, T., Gast, P., Hoff, A. J., and Amesz, J. (1981). *FEBS Lett.* **127**, 83–86.
- Symons, M., Swysen, C., and Sybesma, C. (1977). *Biochim. Biophys. Acta* **462**, 706–717.
- Takamiya, K., and Dutton, P. L. (1979). *Biochim. Biophys. Acta* **546**, 1–16.
- Takamiya, K., Prince, R. C., and Dutton, P. L. (1979). *J. Biol. Chem.* **254**, 11307–11311.
- Thielen, A. P. G. M., and van Gorkom, H. J. (1981). *FEBS Lett.* **129**, 205–209.
- Thielen, A. P. G. M., van Gorkom, H. J., and Rijgersberg, C. P. (1981). *Biochim. Biophys. Acta* **635**, 121–131.
- Thornber, J. P., Alberte, R. S., Hunter, F. A., Shiozawa, J. A., and Kan, K.-S. (1976). *Brookhaven Symp. Biol.* **28**, 132–148.
- Thorne, S. W., Newcomb, E. H., and Osmond, C. B. (1977). *Proc. Natl. Acad. Sci. U.S.A.* **74**, 575–578.
- Thurnauer, M. C., and Norris, J. R. (1977). *Chem. Phys. Lett.* **47**, 100–105.
- Thurnauer, M. C., Katz, J. J., and Norris, J. R. (1975). *Proc. Natl. Acad. Sci. U.S.A.* **72**, 3270–3274.
- Trench, R. K., and Siebens, H. C. (1978). *Proc. R. Soc. London, Ser. B* **202**, 473–482.
- Trench, R. K., Pool, R. R., Logan, M., and Engelland, A. (1978). *Proc. R. Soc. London, Ser. B* **202**, 423–443.
- Trumpower, B. L. (1981). *Biochim. Biophys. Acta* **639**, 129–155.
- Trumpower, B. L., ed. (1982). "Function of Quinones in Energy Coupling Systems." Academic Press, New York.
- Ueki, T., Kataoka, M., and Mitsui, T. (1976). *Nature (London)* **262**, 809–810.
- van den Berg, W. H., Prince, R. C., Bashford, C. L., Takamiya, K., Bonner, W. D., and Dutton, P. L. (1979). *J. Biol. Chem.* **254**, 8594–8604.
- van Gorkom, H. J. (1974). *Biochim. Biophys. Acta* **347**, 439–442.
- van Gorkom, H. J., Tamminga, J. J., and Haveman, J. (1974). *Biochim. Biophys. Acta* **347**, 417–438.
- van Grondelle, R., Duysens, L. N. M., van der Wel, J. A., and van der Wal, H. N. (1977). *Biochim. Biophys. Acta* **401**, 188–201.
- van Grondelle, R., Holmes, N. G., Rademaker, H., and Duysens, L. N. M. (1978). *Biochim. Biophys. Acta* **503**, 10–25.
- van Niel, C. B. (1931). *Arch. Mikrobiol.* **3**, 1–112.
- van Niel, C. B. (1941). *Adv. Enzymol.* **1**, 263–328.
- Velthuys, B. R. (1978). *Proc. Natl. Acad. Sci. U.S.A.* **75**, 6031–6034.
- Velthuys, B. R. (1979). *Proc. Natl. Acad. Sci. U.S.A.* **76**, 2765–2769.
- Velthuys, B. R. (1981). *FEBS Lett.* **126**, 277–281.
- Velthuys, B. R. (1982). In "Function of Quinones in Energy Coupling Systems" (B. L. Trumpower, ed.). Academic Press, New York (in press).
- Velthuys, B. R., and Amesz, J. (1974). *Biochim. Biophys. Acta* **333**, 85–94.
- Vermeiglio, A. (1977). *Biochim. Biophys. Acta* **459**, 516–524.
- Vermeiglio, A., and Clayton, R. K. (1977). *Biochim. Biophys. Acta* **461**, 159–165.

- Vinkler, C. (1981). *Biochem. Biophys. Res. Commun.* **99**, 1095–1100.
- von Jagow, G., Schägger, H., Riccio, P., Klingenberg, M., and Kolb, H. J. (1977). *Biochim. Biophys. Acta* **462**, 549–558.
- Walz, D. (1979). *Biochim. Biophys. Acta* **505**, 279–353.
- Warburg, O. (1964). *Annu. Rev. Biochem.* **33**, 1–13.
- Wasielewski, M. R., Norris, J. R., Shipman, L. L., Lin, C. P., and Svec, W. A. (1981a). *Proc. Natl. Acad. Sci. U.S.A.* **78**, 2957–2961.
- Wasielewski, M. R., Norris, J. R., Crespi, H. L., and Harper, J. (1981b). *J. Am. Chem. Soc.* **103**, 7664–7665.
- Whatley, J. M. (1976). *New Phytol.* **76**, 111–118.
- Whatley, J. M. (1977). *New Phytol.* **79**, 309–313.
- Whatley, J. M., John, P., and Whatley, F. R. (1979). *Proc. R. Soc. London, Ser. B* **204**, 165–187.
- Whitmarsh, J., and Cramer, W. A. (1979). *Biophys. J.* **26**, 223–234.
- Whitmarsh, J., Bowyer, J. R., and Crofts, A. R. (1982). *Biochim. Biophys. Acta.* (in press).
- Wright, C. A. (1977). *Biochim. Biophys. Acta* **459**, 525–531.
- Wright, C. A. (1978a). *FEBS Lett.* **93**, 283–288.
- Wright, C. A. (1978b). In "Frontiers in Energetics: From Electrons to Tissues" (P. L. Dutton, J. S. Leigh and A. Scarpa, eds.), pp. 218–266. Academic Press, New York.
- Wright, C. A. (1979a). *Photochem. Photobiol.* **30**, 767–776.
- Wright, C. A. (1979b). *Biochim. Biophys. Acta* **548**, 309–327.
- Wright, C. A. (1981). *Isr. J. Chem.* **21**, 348–354.
- Wright, C. A. (1982). In "Functions of Quinones in Energy Coupling Systems" (B. L. Trumpower, ed.), Academic Press, New York (in press).
- Wright, C. A., and Clayton, R. K. (1973). *Biochim. Biophys. Acta* **333**, 246–260.
- Wright, C. A., Cogdell, R. J., and Chance, B. (1978). In "The Photosynthetic Bacteria" (R. K. Clayton and W. R. Sistrom, eds.), Chapter 26, pp. 471–511. Plenum, New York.
- Yasunobu, K. Y., and Tanaka, M. (1980). In "Methods in Enzymology" (A. San Pietro, ed.), Vol. 69, pp. 228–238. Academic Press, New York.
- Zanetti, G., and Curti, B. (1980). In "Methods in Enzymology" (A. San Pietro, ed.), Vol. 69, pp. 250–255. Academic Press, New York.
- Zannoni, D., Jasper, P., and Marrs, B. (1978). *Arch. Biochem. Biophys.* **191**, 625–631.
- Zannoni, D., Prince, R. C., Dutton, P. L., and Marrs, B. (1980). *FEBS Lett.* **113**, 289–293.

Part II

Structure and Function

Photosynthetic Membrane Structure and Function

SAMUEL KAPLAN
CHARLES J. ARNTZEN

I. Introduction.....	67
A. Adaptive Advantages of Structural Complexes within Photosynthetic Membranes.....	68
B. Light-Harvesting Pigment-Protein Complexes: Organization into Structural Units.....	68
C. Photosynthetic Systems to Be Described.....	70
II. Photosynthetic Bacteria.....	71
A. Enzymatic and Functional Properties.....	71
B. Structural Diversity.....	75
C. Chromatophore Properties.....	80
D. Structural Organization of Functional Membrane Complexes.....	85
E. Topological and Vectorial Organization of the Photosynthetic Membrane and Its Components.....	97
F. Reconstitution Studies.....	104
G. Membrane Biosynthesis.....	105
III. Chloroplasts.....	109
A. Enzymatic Properties and Polypeptide Composition of Thylakoid Functional Complexes.....	109
B. Thylakoid Pigment-Proteins.....	120
C. Structural Morphology of Thylakoid Membranes.....	123
D. Distribution and Stoichiometry of Pigment-Protein and Electron Transport Components between Stacked and Unstacked Membranes....	127
E. Identification of Freeze-Fracture Particles.....	128
F. The Membrane Component Which Determines Grana Stacking...	133
G. The Function of Grana Stacking.....	135
IV. Conclusions.....	140
References.....	140

ABBREVIATIONS

BChl	Bacteriochlorophyll
Bph	Bacteriopheophytin
CF ₀ , CF ₁	Hydrophobic and hydrophilic components of the coupling factor, respectively
Chl	Chlorophyll
CIE	Crossed immunoelectrophoresis
CL	Cardiolipin

CM	Cytoplasmic membrane of gram-negative bacteria
CPII	Chl-protein complex II
CTAB	Cetyltrimethylammonium bromide
Cyt	Cytochrome
D _{II,1} , D _{II,2} , D _{II,3}	Electron donors 1, 2, and 3 to PSII reaction
DAP	Diaminopimelic acid
DCCD	<i>N,N'</i> -dicyclohexylcarbodiimide
DEAE	Diethylaminoethane
EDTA	Ethylenediaminetetraacetic acid
EF _S , EF _U	Exoplasmic fracture face in stacked and unstacked regions of chloroplast lamellae, respectively
ESR	Electron spin (paramagnetic) resonance
fc	Foot candles
ICM	Intracytoplasmic membrane
kD	Kilodalton(s)
LDAO	Lauryl dimethylamine oxide
LDH	Lactate dehydrogenase
LDS	Lithiumdodecyl sulfate
LHC(I)	Light-harvesting (complex) I
MW	Molecular weight
NAPS	<i>N</i> -acylphosphatidylserine
OM	Outer membrane
PC	Phosphatidylcholine; PC: plastocyanin
PE	Phosphatidylethanolamine
*PF face	Protoplasmic fracture face. External leaflet of cytoplasmic membrane of gram negative
PF _S , PF _U	Protoplasmic fracture face in stacked and unstacked regions of chloroplast lamellae, respectively
PG	Phosphatidylglycerol
PMS	Photosynthetic membrane system
PMSF	Phenylmethylsulfonylfluoride
PRC	Photoreceptor complex
PS	Photosystem
QZ	A special quinone in bacterial cyclic electron transport after Cyt <i>b</i>
RC	Reaction center
<i>Rp.</i>	<i>Rhodospseudomonas</i>
<i>Rs.</i>	<i>Rhodospirillum</i>
RuBP	Ribulose biphosphate
SDH	Succinate dehydrogenase
SDS	Sodium dodecyl sulfate
SDS-PAGE	Sodium dodecyl sulfate-polyacrylamide gel electrophoresis
TNBS	Trinitrobenzenesulfonate
Tris	Tris(hydroxymethyl)aminomethane
UQ	Ubiquinone

ABSTRACT

This chapter is intended to provide the reader with an overview of the structure, function, composition, and biogenesis of photosynthetic membranes within the photo-

synthetic bacteria and chloroplasts. We emphasize the similarities in some aspects of structural organization of reaction center (RC), electron transport, and ATPase complexes in the bacteria and green plants. We also review the evidence for complexes of pigments and proteins in both systems; this includes a discussion of the light-harvesting complexes for both photosystems (PS)I and II in green plants and the involvement of the latter in the processes of grana stacking and regulation of excitation energy transfer.

Various chapters of this volume and those in Volume II also edited by Govindjee (1982) provide greater focus for many but not all of the topics considered here. We have attempted to provide the reader with a comparison of the bacterial and higher plant photosynthetic membrane systems. The gaps in our knowledge will become evident, but nonetheless, the considerable progress over the past few years points clearly to both similarities and specific differences between the two photosynthetic membrane systems.

1. Introduction

The prevailing view of evolution holds that the first prokaryotic cell evolved about 4 billion years ago. Woese (1979) hypothesized that the first living cell was a photoautotroph. Presumably, the earliest cell types carried out simple photoreactions such as light-induced activation of some step in a biosynthetic process. Subsequently, a great deal of biological diversity in these forms of autotrophic energy production developed. A well-studied example among the bacteria is *Halobacterium halobium*; it is now recognized that this bacterium uses a protein-bound rhodopsin to catalyze light-induced proton transfer to create a stored form of energy (Stoeckenius, *et al.*, 1979). The halobacteria represent a relatively minor component of the biological photoautotrophic systems, however. The dominant mechanism for biological solar energy conversion is photosynthesis as carried out by bacteria, algae, and higher plants.

The free energy trapped from light by photosynthesis in higher plants is made available to metabolism in two ways (see Fig. 1 in Chapter 2 by Wraight): (a) reductive power in the form of reduced ferredoxin is utilized to reduce NAD or NADP for CO₂ fixation and nitrate reduction, as well as direct utilization for the reduction of nitrate to ammonia, and (b) ATP is used to displace the equilibrium of coupled kinase reactions during conversion of ATP to ADP. These reactions drive the major metabolic pathways in the direction of synthesis for carbon (Govindjee, 1982) and nitrogen assimilation. The photosynthetic light reactions are, therefore, a series of steps that require the concerted interaction of a number of electron carriers and enzymatic proteins, as well as pigments that sensitize the reactions. A central theme of this chapter is to empha-

size that the efficient functioning of the light reactions requires a precise stoichiometry of various constituent components (the exact stoichiometry may vary according to physiological demands), as well as controlled interactions among the various components of the overall process to insure maximal rates of reactions. These interactions define the organized structure of the photosynthetic membranes—the topic of this chapter.

A. Adaptive Advantages of Structural Complexes within Photosynthetic Membranes

It is now recognized that the primary step in all photosynthetic light reactions is a charge separation of a special chlorophyll (Chl) (or Chl pair) that occurs within a reaction center (RC) (see Section II,A, and Okamura *et al.*, Chapter 5, this volume). One can assume that some type of simple RC system must have been an early evolutionary development in prokaryotic cells that were destined to be photosynthetic. Without belaboring the detail, one can easily assume that the photosynthetic process became more energy efficient as additional components were added to the RC; electron acceptors and/or electron donors would have resulted in prolonged stabilization of the charge separation, thus increasing the probability of desired coupled chemical reactions. In addition, development of coordinated proton transporting systems would have increased the available forms of stored energy. This introduction is not meant to emphasize evolutionary aspects of development; it is instead to stress that development of a refined photosynthetic process increased the demands on the physical organization of the system. In part, we can now recognize that vectorial movement of reactants has been guaranteed by the fact that all systems that use photosynthetic light reactions are embedded in membrane structures with a fixed orientation (inside versus outside). Second, to confer specific interactions among various functional components of the light reactions, photosynthetic systems have evolved in which clusters of enzymes are structurally associated into aggregate complexes.

B. Light-Harvesting Pigment-Protein Complexes: Organization into Structural Units

During the evolution of photosynthetic membranes, the appearance of accessory pigments must have been of greater importance as increasing complexity of the electron transport system appeared; the cellular

“biosynthetic energy” invested in synthesis of charge separation components would only have been returned if there were sufficient radiant energy collected to accomplish high turnover rates of the system. Developmental controls that support this conjecture are now well recognized. Photosynthetic bacteria, algae, and higher plants regulate the amounts of light-harvesting (LH) components synthesized in response to environmental light intensity conditions.

Over the last few years, it has become accepted that all LH Chls are associated with proteins. There are several obvious teliological explanations for this fact, including: (a) spatial distances and orientations between antennae pigments and RC Chls can be maintained to maximize energy transfer to the trap; (b) microenvironments within proteins can create, in a defined and constant way, the properties of the associated pigments to create unique spectral species, which can broaden the absorption spectrum; and (c) protein properties or interactions can be regulated (covalent modifications, salt, phosphorylation, or pH-induced changes, etc.) to change associations of the LH pigment with a specific RC complex in order to regulate excitation energy distribution among photosystems. This chapter will summarize the information (albeit incomplete) that describes the specific biochemical identity of electron transport carrier proteins and pigment-proteins and data that relates to how these components are assembled into aggregate complexes.

Although there are many similarities and uniformities among the prokaryotes and eukaryotes with respect to electron-transport functions and the mechanisms of ATP synthesis, elaborate diversity has evolved in the chromophores, which sensitize these reactions and in the structural units in which the pigments are organized. The principal distinction among LH properties of photosynthetic cells lies in the patterns of pigment localization. In the evolution of both prokaryotes and eukaryotes, there have been phylogenetic branch points leading to pigment-protein complexes, which are either hydrophobic (internal membrane localization) or hydrophilic (membrane surface-bound).

It has been hypothesized that the cyanobacteria, cyanophora, and red algae represent a phylogenetic sequence (Stanier and Cohen-Bazire, 1977). The antenna pigments of these organisms are Chl and phycobiliproteins; the latter are coordinately assembled into structural units termed *phycobilisomes* (Kirk and Tilney-Bassett, 1978). The phycobilisomes are physically localized on the outer surface of the photosynthetic membranes and can be easily released as water-soluble subunits. Information relating to the protein and chromophore organization of phycobilisomes is too extensive to be included in the current chapter; the

reader is referred to Gantt *et al.* (1977), Stanier and Cohen-Bazire (1977), and Kirk and Tilney-Bassett (1978) for more detail.

A major emphasis of this chapter will be upon discussion of the hydrophobic pigment-protein complexes that act as LH units for the purple bacteria (Rhodospirillaceae and Chromatiaceae) as well as the LH complexes of green plant chloroplasts.

C. Photosynthetic Systems to Be Described

Three bacterial representatives capable of anoxygenic photosynthesis will be considered in this chapter. These organisms are members of the family Rhodospirillaceae, Chromatiaceae, and Chlorobiaceae (Pfennig and Trüper, 1974; Pfennig, 1977, 1978; Trüper and Pfennig, 1978). Although there are many physiological and anatomical distinctions characterizing each of these families, a major distinction for purposes of this discussion is that the former two families have both their LH and RC activities within the same membrane system (Oelze and Drews, 1972), whereas members of the Chlorobiaceae have structurally separated these activities (Cohen-Bazire *et al.*, 1964; Staehelin *et al.*, 1980). For a discussion of the phylogenetic relationships amongst the purple representatives, see Woese *et al.* (1980).

Members of the Rhodospirillaceae grow photoheterotrophically with many representatives also capable of chemoheterotrophic growth. This is important when considering the functional and developmental relationships of the photosynthetic membrane system (PMS) to cytoplasmic membrane (CM). The Chromatiaceae and the Chlorobiaceae on the other hand are, in general, photoautotrophs. The diverse morphologies of the PMS present in both the Rhodospirillaceae and Chromatiaceae have been thoroughly described (Oelze and Drews, 1972).

Finally, the purple bacteria (Rhodospirillaceae and Chromatiaceae) contain either BChl *a* or *b* (Pfennig and Trüper, 1974), although small amounts of BChl *b* ($\geq 5\%$) may be present in those species containing predominantly BChl *a* (Gloe and Pfennig, 1974). Members of the Chlorobiaceae contain in addition to BChl *a*, BChl *c*, *d*, or *e* (Gloe *et al.*, 1975).

The chloroplast membranes to be described are those of the green algae and of higher plants, with primary emphasis on the latter. These plants contain Chl *a* and Chl *b*.

For a discussion of biosynthesis and chemistry of pigments, particularly Chl *a*, see Rebiez and Lascelles (Chapter 15, this volume); and for a discussion of biosynthesis of membranes, see Ohad and Drews (Chapter 5) in Volume II, also edited by Govindjee (1982).

II. Photosynthetic Bacteria

A. Enzymatic and Functional Properties

1. MINIMAL FUNCTIONAL PROPERTIES

The minimal functional requirements associated with the PMS of the bacterial groups are the LH activities resulting in the absorption of incident light and transfer the electronic excitation to the RC (Sauer, 1975; Amesz, 1978; Zankel, 1978), where primary photochemistry occurs. A BChl dimer [BChl_2 (Netzel *et al.*, 1973)], which is part of the P870 complex, represents the primary electron donor (Clayton, 1978; Leigh, 1978; Norris and Katz, 1978) and, when excited, transfers an electron to the "primary" electron acceptor (Leigh, 1978; Prince and Dutton, 1978). Thus electronic excitation energy is transformed into chemical energy. The resulting special BChl dimer is in the oxidized state, $[\text{BChl}]_2^+$, and the existence of a transient intermediate between the primary donor and acceptor has been demonstrated in some systems (Dutton *et al.*, 1977; Leigh, 1978). The $[\text{BChl}]_2^+$ is immediately reduced. For details, see Okamura *et al.*, Chapter 5, and Parson and Ke, Chapter 8, this volume. At this point, it is possible to consider the separation and isolation of both the LH complex(es) and RC complex as functional and structural entities. In general, the primary reductant is unable to effect the reduction of pyridine nucleotides, except perhaps for the primary acceptor of the green bacterium *Chlorobium (Chl.) limicola f. thiosulfatophilum* (Prince and Olson, 1976) (see Fig. 1 in Wraight, Chapter 2, this volume). An enzyme system similar to that found in green plants has been isolated from this organism (Buchanan and Evans, 1969). In the purple bacteria, there is convincing evidence that reverse electron flow, dependent upon a succinate-linked NAD^+ photoreduction, takes place employing ATP as the ultimate energy source (Keister and Yike, 1967; Jones and Saunders, 1972).

From the primary acceptor, the transfer of electrons occurs in the absence of the net production of any oxidized or reduced chemical species, i.e., cyclic electron flow. Electron flow is coupled to ATP production, with all of these reactions present within the PMS. The orientation of these components are asymmetrically distributed within the membrane so that both a proton gradient and electrochemical potential are generated across the membrane (Mitchell, 1966; Jackson and Crofts, 1969). A large quinone pool, primarily ubiquinone (UQ)-10 has been shown to exist in the chromatophores of the Rhodospirillaceae (Lester

and Crane, 1959; Clayton, 1962; Okayama *et al.*, 1968; Baccarini-Melandri and Melandri, 1977; Parson, 1978), and this pool may be involved in interconnecting otherwise separate electron transport chains. Furthermore, Q_z together with cytochromes (Cyt) serve to complete the cyclic electron transport chain together with proton translocation.

Following reduction of the primary acceptor (Q_A or Q_I), the electron is transferred to a secondary acceptor (Q_B or Q_{II}), a special quinone (Halsey and Parson, 1974; Okamura *et al.*, 1975; Vermeglio, 1977; Wraight, 1977; Parson, 1978) that appears to bridge the gap between the RC and the rest of the electron transport chain. For details on electron transport, see Cramer and Crofts, Chapter 9, this volume. In *Chromatium (Chr.) vinosum* (Halsey and Parson, 1974), *Rhodospseudomonas (Rp.) sphaeroides* (Petty and Dutton, 1976), and *Rp. viridis* (Carithers and Parson, 1975), proton uptake either accompanies the reduction of this quinone or follows the transfer of the electron from this quinone to a quinone pool existing outside the RC. This quinone pool has been considered part of the UQ-Cyt $b-c_2$ oxidoreductase (Crofts and Bowyer, 1977; Petty *et al.*, 1977; Prince and Dutton, 1977) described by Takamiya and Dutton (1979) to consist of a pool of 19 UQ molecules and able to bind 2 protons for each electron moving through the $Q/b/c_2$ oxidoreductase (Petty *et al.*, 1979). Although the specific Cyt b and c may vary depending upon the organism under investigation (Dutton and Prince, 1978; Melandri and Zannoni, 1978), a general, although as yet incomplete, picture of the terminal portions of cyclic electron flow is emerging. Both electrons and protons are transferred to Cyt b (Petty and Dutton, 1976; Crofts *et al.*, 1977), which is intimately coupled to a special quinone (Q_z) (Cogdell *et al.*, 1972; Petty and Dutton, 1976; Petty *et al.*, 1979), which in turn is able to reduce, through a Rieske iron-sulfur protein (Bowyer and Crofts, 1978; Bowyer *et al.*, 1979; Crofts, 1979), the oxidized form of the appropriate Cyt c_2 (Evans and Crofts, 1974; Prince and Dutton, 1977; Dutton and Prince, 1978) thereby releasing protons to the interior. To complete the cycle, the $[BChl]_2^+$ dimer is reduced and the Cyt c_2 reoxidized (Duysens, 1954; Dutton and Prince, 1978). Dutton *et al.* (1975) indicated that there are 2 molecules of Cyt c_2 per RC, although other evidence suggests only 1 molecule per RC (Bowyer *et al.*, 1979). Finally, there is evidence (Prince and Dutton, 1977; Petty *et al.*, 1979) that the oxidation-reduction state of Q_z strongly influences the rate of electron transfer through the chain. It has not yet been possible to isolate submembranous fractions containing isolated portions of the cyclic electron transport chain. This may be a reflection of the asymmetric location of these components within the PMS.

2. ENERGY COUPLING

The conversion of the electrochemical potential developed as the result of the movement of electrons and protons across the PMS into the high energy bond of ATP is the result of the coupling factor (or ATPase) activity resident on the inner surface of the PMS. The theoretical aspect of this conversion was described by Mitchell (1966). Frenkel (1954) and others, e.g., Baccarini-Melandri *et al.* (1970), demonstrated the light-induced phosphorylation of ADP by chromatophores in *Rp. capsulata*, and Johansson *et al.* (1972) demonstrated that the ATPase could be removed and restored to chromatophores of *Rs. rubrum*. Similar results have been shown for *Rp. sphaeroides* (Reed and Raveed, 1972) and *Chr. vinosum* (Gepshtein and Carmeli, 1974). The coupling factor has been shown to consist of two distinct structural entities, the hydrophilic F_1 portion, which contains the catalytic centers (Yoshida *et al.*, 1977), and the hydrophobic F_0 (Futai *et al.*, 1974) portion, which is integral to the membrane. For a review of the general properties of the ATPase and the mechanisms of photosynthetic phosphorylation, see Baltscheffsky (1977, 1978), and chapter 12 by Ort and Melandri, Chapter 13 by Junge and Jackson, and Chapter 14 by McCarty and Carmeli, in this volume.

3. SUCCINIC DEHYDROGENASE

Hatefi *et al.* (1972) were able to remove the tightly bound succinate dehydrogenase (SDH) activity from the chromatophore membranes of *Rs. rubrum* through the use of chaotropic agents. The enzyme was ultimately purified (Davis *et al.*, 1977) and shown to have a mass of 85 kD and to contain two subunits of 60 and 25 kD. The enzyme contains approximately 8 g atoms of non-heme iron and between 7–8 moles of acid-labile sulfide per mole of flavin. Analysis of the subunits reveals that each contains iron and labile sulfide. Carithers *et al.* (1977) isolated the SDH from *Rs. rubrum* chromatophores employing either lauryl dimethylamine oxide (LDAO) or alkaline washes. The purified enzyme has a mass similar to that reported earlier and contains flavin : non-heme iron : acid-labile sulfide in the ratio 1 : 8 : 8. Like other SDH enzymes, this enzyme contains two iron-sulfur centers of the ferredoxin type and one center of the high potential type. However, this enzyme also contains an additional center of the ferredoxin type. Ingledew and Prince (1977) removed the SDH activity from chromatophores of *Rp. sphaeroides* and detected the presence of two ferredoxin-like centers, as well as a high potential center. Importantly, removal of SDH from the chromatophores has no effect upon cyclic electron flow and like the F_1

portion of the ATPase, the SDH activity can be rebound to the chromatophore surface.

Yoch and co-workers (1977) found that in addition to the removal of SDH from *Rs. rubrum* chromatophores with LDAO, two additional membrane-bound iron-sulfur proteins are also removed. These have been designated ferredoxins III and IV. Investigation of ferredoxin III is hampered due to its lability. However, ferredoxin IV has eight iron and eight labile sulfur centers. The physiological role of these new ferredoxins remains obscure, although each has a low enough oxidation-reduction potential to reduce either NAD^+ or NADP.

4. IRON-SULFUR CENTERS

Other iron-sulfur centers similar to those of the SDH of *Rp. sphaeroides* and *Rs. rubrum* have also been found in *Chromatium* (Evans *et al.*, 1974), *Chlorobium* (Knaff and Malkin, 1976) and *Rp. capsulata* (Prince *et al.*, 1974). It is possible that some of these may be associated with NADH dehydrogenase activity (Ingledeew and Prince, 1977). Other centers of the Rieske (Evans *et al.*, 1974; Prince *et al.*, 1974; Knaff and Malkin, 1976; Prince and Dutton, 1976; Carithers *et al.*, 1977) iron-sulfur-type may be associated with proton transduction as well as electron transport, and such evidence has now become available (Bowyer and Crofts, 1978; Bowyer *et al.*, 1979; Crofts, 1979). Finally, a Rieske center described for *Chlorobium* (Knaff and Malkin, 1976) and characterized by Prince and Olson (1976) may exist as a stable acceptor in its photochemistry.

Other activities associated with the PMS are not as well studied as those cited earlier and will be mentioned only in passing. However, these activities, together with those previously described and, perhaps, others, amply justify our view of the complexity of the PMS. Jacobs *et al.* (1977) described a pyridine dinucleotide transhydrogenase from *Rs. rubrum* chromatophores that consists of at least two components, one an easily dissociable soluble factor and the other an integral membrane component removable upon lysolecithin extraction.

5. HYDROGENASES

Another enzyme system solubilized from the PMS of *Rs. rubrum* (Adams and Hall, 1979), *Thiocapsa* (Gogotov *et al.*, 1978), and *Chromatium* (Gitlitz and Krasna, 1975) is able to catalyze either the uptake or evolution of H_2 in the light. The hydrogenases of these three organisms bear many common properties. Although different in size, the *Rs. rubrum* enzyme is a monomer of 66-kD protein; the *Chromatium* enzyme is a dimer of 98-kD protein, that is composed of two apparently identical subunits. Each of these enzymes contain four iron and four acid labile

sulfurs of the high potential type, and neither is inhibited by O_2 . The *Chromatium* enzyme is able to reduce NAD^+ in the presence of ferredoxin in crude extracts, but not when purified. The suggestion has been made that essential, but as yet unidentified, factors are lost during the early stages of purification.

The PMS also appears to be involved in the regulation and activation of the nitrogenase of *Rs. rubrum* (Nordlund and Eriksson, 1979). Because of the complexity of the control systems involved in nitrogen metabolism, much more needs to be done before any firm conclusions can be reached.

Another interesting activity associated with the PMS of *Rs. rubrum* is the light-induced synthesis of pyrophosphate coupled to electron flow (Baltscheffsky and von Stedingk, 1966). Along with ATP, PP_i can serve as an energy-donor for numerous other energy-linked reactions associated with the PMS (Rao and Keister, 1978). This activity has been solubilized from the chromatophores with cholate in the presence of $MgCl_2$ (Rao and Keister, 1978); the enzyme requires phospholipid for its activity. Barrett and Jones (1978) demonstrated the localization of the enzyme ferrochelatase, which inserts ferrous iron in porphyrins, on the cytoplasmic surface of the chromatophores of *Rp. sphaeroides*. Lastly, the enzyme adenylylsulfate reductase appears to be firmly bound to the chromatophores of *Chr. vinosum* (Schwenn and Biere, 1979), although Trüper and Peck (1970) found that the enzyme was easily lost from the chromatophores of *Thiocapsa roseopersicina*. This brief survey illustrates the significance and complexity of this membrane system.

B. Structural Diversity

We find numerous structural forms and associations of the PMS, which are species specific. This is because the PMS must reflect, in addition to housing the elements of structure and function relevant to photosynthetic activity, activities necessarily associated with a free-living organism. The diversity of photosynthetic membrane forms has been reviewed (Oelze and Drews, 1972; Pfennig and Trüper, 1974; Remsen, 1978). Members of the Rhodospirillaceae and Chromatiaceae form a variety of intracellular morphological structures, which are functionally and structurally differentiated membrane systems and which house the photosynthetic as well as related activities. The Chlorobiaceae, on the other hand, appear to have many of the energy-transducing activities associated with the cell membrane with the antenna functions associated with specialized nonmembranous chlorosomes (Staehelin *et al.*, 1980). In addition, members of the Rhodospirillaceae, since they are photohet-

erotrophs, have the ability to "turn on" or "turn off" the synthesis of their specialized PMS (Kaplan, 1978). In the absence of the PMS, members of this group grow as chemoheterotrophs. Therefore, in this section we will consider, briefly, the interrelationships of these membrane systems, the isolation of the PMS, and the gross morphological and chemical structure of the PMS.

1. CHLOROBIACEAE

The isolation and structural relationships of the PMS from the Chlorobiaceae remain relatively unexplored and therefore incomplete. However, from several publications (Olson *et al.*, 1977; Pierson and Castenholz, 1978; Drews and Oelze, 1981) and a reinterpretation of earlier work (Bergeron and Fuller, 1961; Fuller and Boyce, 1976), the following picture seems to emerge. The antenna function is located in non-membranous particulate structures, chlorosomes, whose numbers and size can vary depending upon light intensity. The chlorosomes in turn are structurally affixed to or embedded in the cell membrane at discrete locations. These sites have been structurally characterized (Staehelin *et al.*, 1980), and it appears that on the average 30 particles of approximately 12.5-nm diameter represent the attachment site of the chlorosome to the CM. The particles are thought to contain the noncrystalline LH complex, the RC complex, and the primary acceptor. The precise location of other components of the electron transport chain remains to be determined, but these must be asymmetrically distributed within the membrane and in close proximity to the 12.5-nm particles. Fractionation techniques have been developed (Olson *et al.*, 1977) for the isolation of various functional activities that are in general agreement with the structural features outlined. Cells of *Chl. limicola f. thiosulfatophilum* can be disrupted by passage through the French pressure cell and the crude extract can be clarified by centrifugation. The supernatant is centrifuged at high *g* forces on a sucrose gradient. The lower band (fraction I) is membranous in nature and probably represents the CM, 12.5-nm particles, and associated components. The upper band contains the bulk of the *Chlorobium* Chl. Fraction I can be subdivided into residual membranes containing the RC, electron transport chain, and firmly embedded BChl *a* (fraction II). The bulk of the BChl *a* is dissociated from fraction II. However, the bulk of the CM would appear to remain associated with the RC complex and electron transport components. Because of the difficulty in resolving the PMS from the CM, analysis of the gross chemical composition of these membranes is premature.

2. CHROMATIACEAE

The isolation of the PMS of the Chromatiaceae, although somewhat better documented than the Chlorobiaceae, has not been as extensively analyzed as the Rhodospirillaceae. One of the earliest and most detailed studies was carried out by Takacs and Holt (1971a), who employed several cycles of differential centrifugation followed by RbCl centrifugation. The preparation was monitored for purity by electron microscopy. Although highly purified, some membranous and ribosomal contaminations were evident. The purified chromatophores contained approximately 49% protein, 47% lipid, and 3% BChl (Takacs and Holt, 1971b). For *Ectothiorhodospira mobilis*, Oyewole and Holt (1976) prepared spheroplasts, which were ultimately disrupted by osmotic shock. The crude PMS was isolated following differential centrifugation and purified following RbCl and sucrose gradient centrifugation. The composition was approximately 60% protein, 32% phospholipid, and a few percent BChl.

Hurlbert *et al.* (1974) employed a somewhat different approach for the isolation of *Chr. vinosum* chromatophores. A total membrane fraction was isolated following lysozyme-ethylenediaminetetraacetic acid (EDTA) spheroplast formation and cell lysis. The membranes were fractionated by isopycnic sucrose density-gradient centrifugation, and three fractions were resolved. The middle fraction appears to be the most highly enriched for BChl, although it contains considerable diamino-pimelic acid (DAP), presumably resulting from the presence of peptidoglycan. The upper fraction has only traces of DAP and the heaviest fraction (lowest) appears to be cell envelope material with only a trace of chromatophores. Chromatophores were also prepared following the procedure of Cusanovich and Kamen (1968) involving French press disruption, differential centrifugation, and discontinuous sucrose-gradient centrifugation. This method gives only a single diffuse-band equivalent to the middle fraction described earlier. These approaches undoubtedly yield the purest chromatophore preparations and are to be distinguished from other methods where only an enriched membrane fraction is required (Lin and Thornber, 1975; Romijn and Amesz, 1977).

3. RHODOSPIRILLACEAE

In contrast to studies with the Chlorobiaceae and Chromatiaceae, the procedures for the isolation of chromatophores from members of the Rhodospirillaceae are exhaustive and are well described by Niederman

and Gibson (1978). A procedure developed by Fraker and Kaplan (1971) involves the disruption of *Rp. sphaeroides* by two passages through the French pressure cell, followed by low- and high-speed centrifugation and isolation of the crude particulate fraction. The particulate fraction is passed over a column of Sepharose 2B, where the envelope and approximately 10–30% of the chromatophores come off in the void volume; the remainder of the chromatophores are eluted following the envelope fraction. The chromatophores are pelleted, resuspended, and purified, using either a continuous sucrose gradient or a step gradient. The overall recovery is high, and the chromatophores are exceptionally pure. The procedures can be easily scaled up or down in order to accommodate any amount of starting material. These results have been confirmed by Niederman and Gibson (1978) and Lommen and Takemoto (1978b). Furthermore, the orientation of the purified chromatophores is at least 97% reversed relative to the CM (Lommen and Takemoto, 1978b). Fraker and Kaplan (1972) further demonstrated that during the purification procedure particular attention must be paid to the buffer system, Mg^{2+} concentration and the inclusion of chelating agents, otherwise nonspecific adsorption of nonchromatophore soluble and particulate components will occur. The chromatophores are 64% protein, 25% phospholipid, and 4.6% BChl. However, such rigorous criteria of purification cannot discriminate between loosely bound, but true, chromatophore components and nonspecifically adsorbed materials. Hence, it is possible to lose important components; see Section II,D for discussion of F_1 portion of ATPase.

Holt and Marr (1965) developed a procedure for the purification of chromatophores from *Rs. rubrum*. Although the chromatophores appear pure by electron microscopy, no other criteria of purity were presented. Collins and Niederman (1976), in a very careful analysis, demonstrated the isolation of a pure preparation of chromatophores from *Rs. rubrum*.

Because there is considerable evidence (reviewed later in Sections II,C and II,E) that the PMS and the CM in *Rp. sphaeroides* and *Rs. rubrum* are contiguous membrane systems whose lipid bilayers are continuous, it is imperative that the isolation of chromatophores devoid of CM, and CM devoid of chromatophores, be easily accomplished. A report by Holmqvist (1979) disputes the physical continuity between the CM and PMS. In these studies, the deposition of iron from ferrous gluconate was used to show that the periplasm and internal compartment of the PMS are not continuous. The evidence cited earlier indicates that the isolation of chromatophores free of CM and envelope is simply and rapidly performed. However, the isolation of CM free of chromatophores is considerably more difficult. Parks and Niederman (1978) reported the isola-

tion of a CM-like fraction containing less than 7% chromatophore contamination. Based upon SDH activity, the overall recovery of this fraction was less than 1%, although the authors did not make any effort to quantitate recovery of this fraction. Further complicating these studies is the presence of the outer membrane (OM), which is routinely present in Gram negative bacteria. However, the demonstration of a BChl-depleted CM fraction from photosynthetically growing cells of *Rp. sphaeroides* (Guillotin and Reiss-Husson, 1975; Parks and Niederman, 1978) is important because it tells us a great deal about membrane organization and development in these cells. One further point is that the isolation of a BChl-depleted CM fraction is possible for the present only in cells grown under high light conditions where the level of CM relative to PMS is high (Kaplan, 1978). However, in low light-grown cells, where the reverse is true, the isolation of a BChl-depleted CM membrane fraction has not been reported. Experiments in Kaplan's laboratory demonstrated the quantitative separation and isolation of the cell envelope virtually free of chromatophores in either low or high light-grown cells of *Rp. sphaeroides*. The question remains: Is the small amount of BChl associated with the CM, which is isolated from high light-grown *Rp. sphaeroides*, merely due to contamination of the CM with chromatophores or is it a more specific association, such as the presence of photosynthetic units as actually part of the CM structure and at a site where there are no PMS invaginations (Lascelles, 1968; Cellarius and Peters, 1969; Oelze and Drews, 1972; Peters and Cellarius, 1972; Michels and Konings, 1978)? The answer to this question is important since many components of the PMS and CM are shared (Jones, 1977), and efforts are underway (see Section II,E) to determine the orientation of these many components. In either case, however, it is obvious that the PMS and the CM from phototrophic cells of *Rp. sphaeroides* are compositionally quite different despite their physical continuity. Michels and Konings (1978) reached a different conclusion, but their method of preparation yields crude membrane fractions at best. This implies that neither the proteins of the PMS nor those of the CM are freely diffusible between these membrane systems. However, we can say nothing about their lateral mobility within their respective membrane systems.

Although most of the work in this area has been performed with *Rp. sphaeroides* and *Rs. rubrum*, chromatophores have been isolated from many members of the Rhodospirillaceae, although the detailed characterization is lacking (Niederman and Gibson, 1978). One interesting observation made by Wakim *et al.* (1978) revealed that *Rs. tenue* does not form an elaborate PMS, but it increases its membrane content through cell elongation.

C. Chromatophore Properties

1. STRUCTURE AND ORIENTATION

There are numerous electron microscopic studies demonstrating the continuity of the PMS and the CM (see reviews by Drews, 1978; Drews and Oelze, 1981; also see Lascelles, 1968; Cellarius and Peters, 1969; Peters and Cellarius, 1972). Furthermore, the structural and functional implications of isolated chromatophores is that their orientation is opposite to that of the CM. (This evidence will be reviewed later in this section, but the earliest observations of this kind were made by Crofts, 1970.) However, if this is true then electron microscopic characterization of these membrane systems in whole cells or in isolated fractions should bear this out. Additionally, such studies could provide us with information pertinent to the structure and localization of important functional units within the PMS.

Reed and Raveed (1972) demonstrated that if care was taken during the isolation of chromatophores from *Rp. sphaeroides*, they appeared smooth in negatively stained preparations with 9-nm-diameter particles on the outer surface. Treatment with Triton X-100 or EDTA removed these particles from the membrane surface such that they were now found in the supernatant together with ATPase activity, which is normally associated with the untreated chromatophores. We (S. K.) have observed that the "release" of the ATPase activity from the chromatophores of *Rp. sphaeroides* by EDTA can be inhibited by the presence of the protease inhibitor phenylmethylsulfonylfluoride (PMSF) during EDTA treatment. PMSF does not inhibit ATPase activity while particulate or following elution with EDTA. Kaplan and co-workers concluded that the release of the ATPase with EDTA is due to the activation of a protease by EDTA washing. Whether or not the same is true for Triton X-100 extraction remains to be determined. Furthermore, Kaplan and co-workers found that following the release of SDH activity from membranes of chemotrophically grown *Rp. sphaeroides* with perchlorate, SDH activity is rapidly lost unless protease inhibitors are added during extraction. The presence of proteases, either latent or active, should be considered during the handling and extraction of membrane components. (If one does not observe a change in SDS-PAGE profiles of solubilized membranes, it is not necessarily safe to conclude that proteases are not a problem.)

As a result of numerous electron microscopic investigations of members of the Rhodospirillaceae and Chromatiaceae families, the following conclusions may be drawn (Holt *et al.*, 1968; Crofts, 1970; Takacs and Holt, 1971a,b; Reed and Raveed, 1972; Golecki and Oelze, 1975;

Oyewole and Holt, 1976; Lommen and Takemoto, 1978a,b; Michels and Konings, 1978; Wakim *et al.*, 1978; Golecki *et al.*, 1979): The CM and PMS are in the same orientation within the cell, but when isolated the CM and chromatophores are in opposite orientation, with the chromatophores being inside-out (Crofts, 1970; Takacs and Holt, 1971a; Lommen and Takemoto, 1978a,b; Michels and Konings, 1978; Golecki *et al.*, 1979). The isolation of CM-enclosed vesicles is complicated by the report that spheroplasts can only be prepared from cells grown at high light intensities (Lommen and Takemoto, 1978a; Michels and Konings, 1978). Under such conditions it is believed that the isolated vesicles, which are heterogeneous in size, are chimeras containing both CM and PMS, in which case the latter has been inverted relative to its *in situ* orientation as the result of the internal osmotic pressure and the absence of the outer envelope. S. K. observed that if Weiss's (1976) procedure for spheroplast preparation is used on *Rp. sphaeroides*, then excellent spheroplasts can be made regardless of the light intensity used for growth. Lommen and Takemoto (1978a) estimate that 70% of the spheroplast vesicles are right-side-out, whereas 97% of the purified chromatophores are inside-out. Michels and Konings (1978) reported similar observations and further demonstrated light-dependent transport of L-alanine into vesicles, but not into chromatophores, and the reverse was true for light dependent transport of Ca^{2+} . Additional support for this model is derived from the ultrastructural studies of Crofts (1970) and Golecki and Oelze (1975), who observed numerous "indentations" on the protoplasmic fracture (PF) face of the CM of *Rs. rubrum*. The dimensions of these indentations are comparable to the invaginations observed in thin sections, and their number bear a rough correlation to the specific cellular BChl content. These "indentations" are not observed in chemotrophically grown cells, and, when present in phototrophic cells, are marked by a ridge of densely packed particles.

The distribution of particles on the freeze-fracture faces of the CM, spheroplast-derived vesicles, and chromatophores is entirely compatible with the conclusions drawn earlier. Lommen and Takemoto (1978a) observed approximately 14.6 11–12-nm diameter particles per 10^4 nm^2 of the PF face of the CM in whole cells. On the PF face of vesicles derived from phototrophic cells, they observe 31.3 particles per 10^4 nm^2 . In either case, this is the convex face. Using isolated chromatophores, they observed numerous particles on the concave face, as would be predicted (see also Michels and Konings, 1978).

Golecki *et al.* (1979) attempted to relate the increase in particles of mean diameter 9.5 nm with PMS development in *Rp. capsulata*. In dark, high-aeration cells, they observed 28.1 particles per 10^4 nm^2 on the PF

face of the CM. For dark, low-oxygen cells, the number is 44 per 10^4 nm² in one set of experiments and 34 per 10^4 nm² in a second set of experiments. For anaerobic, light-grown cells, the average value is 34 per 10^4 nm² on the PF face of the CM. For isolated chromatophores, 52 particles per 10^4 nm² is observed. They calculated that the RC complex together with LH(I) complex having a combined molecular value of 500 kD would be compatible with a particle size of 9.5-nm diameter. Therefore, they concluded that the increase in 9.5-nm particles found on the PF face of the CM following low oxygen or anaerobiosis represents the accumulation of RC-LH(I) complexes. Although it might be correct, their results may also be interpreted differently. The presence of numerous particles of similar-size distribution on the PF face of chemotrophically growing cells indicates that structural complexes other than RC-LH(I) are physiologically important, and those conditions that promote PMS development may also necessitate the requirement for additional CM structures. Lastly, it must be pointed out that conflicting evidence exists as to whether or not the particles observed are actually protein in nature (Branton and Deamer, 1972) since other possibilities do exist (Cullis and De Kruijff, 1979).

2. CHLOROSOMES

Staehelin and co-workers (1980) have proposed a model for the structure of a chlorosome and CM-attachment region of *Chl. limicola* (see Fig. 1). The chlorosomes are variable in size, from less than 100 nm in length to under 300 nm in length. Their width can vary from under 50 to over 100 nm. The core is hydrophobic and contains many rod-shaped elements of approximately 10 nm in diameter, which run the full length of the chlorosome. These appear to be composed of BChl *c*-protein complexes and are embedded in an amorphous substance. The core is surrounded by a lipid-like cover, composed of galactosyl diglyceride molecules, which form the interface of the chlorosome and surrounding cytoplasm. A baseplate of regularly arranged BChl *a*-protein complexes, approximately 5-nm thick, connects the chlorosome to the CM. The CM, which is appressed to the baseplate, is enriched with 20-30 particles greater than 12-nm-diameter thick, which are believed to contain RC and BChl *a*-protein complexes.

3. RHODOPSEUDOMONAS SPHAEROIDES CHROMATOPHORE COMPOSITION

Prior to proceeding with a detailed analysis of some of the major functional and structural components of the PMS, it is important to summarize the gross structure and composition of the material that most

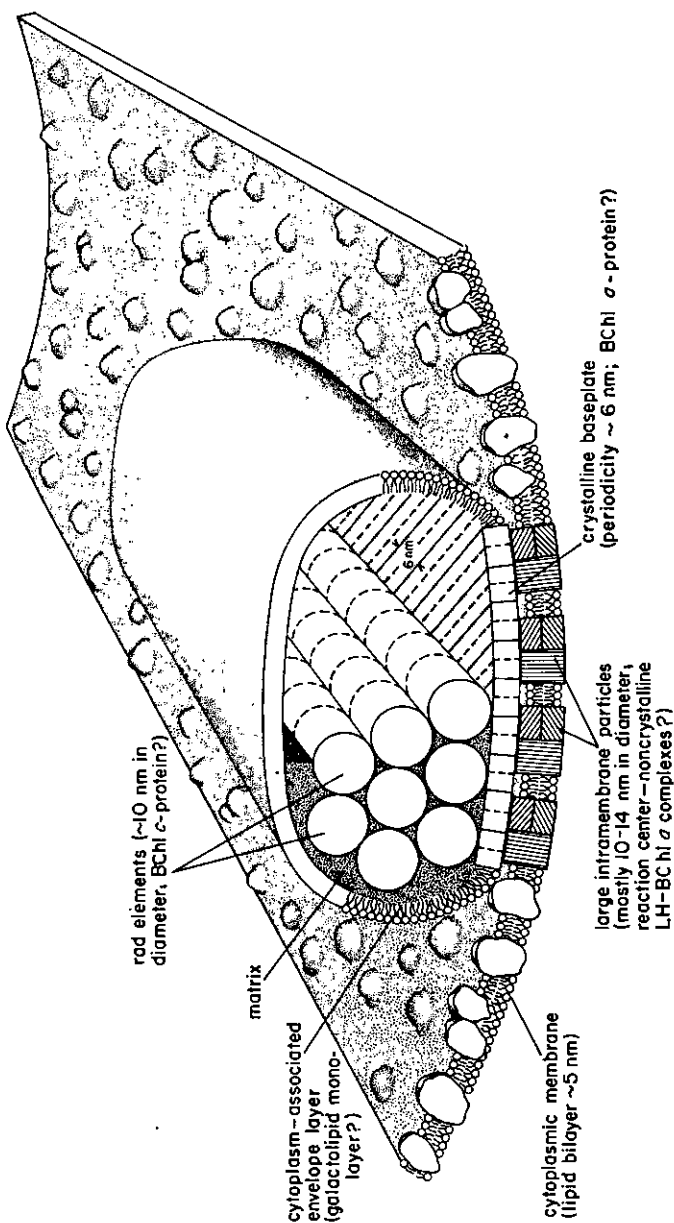

FIG. 1. Model of a chlorosome and its associated cytoplasmic membrane of *Chlorobium limicola* based on the freeze-fracture observations made by Staehelin *et al.* (1980), as well as on biochemical and biophysical studies of others. The hydrophobic core of the chlorosome contains between 10 and 30 longitudinally oriented rod elements (approximately 10 nm in diameter) surrounded by matrix material. It is proposed that the rods contain BChl *c* complexed with specific proteins. The 2–4-nm-wide envelope layer adjacent to the cytoplasm is poorly defined, but it may contain the monogalactolipid molecules in a monolayer configuration. A crystalline baseplate (5–6-nm thick; periodicity approximately 6 nm) provides the mechanical and presumably functional coupling between the LH components in the chlorosome core and the reaction centers in the cytoplasmic membrane. The crystalline nature of the baseplate and its intermediate location suggest that it consists of BChl α -protein complexes organized in the form of a lattice. The membrane attachment site of the chlorosome contains on the average about 30 large intramembrane particles that could represent complexes consisting of a RC and tightly bound, noncrystalline antenna BChl α -proteins. (Reprinted with the permission of Elsevier/North-Holland Biomedical Press and L. A. Staehelin. From Staehelin *et al.*, 1980.)

investigators employ for further analyses. Because the bulk of the work has been with the Rhodospirillaceae, especially *Rp. sphaeroides* 2.4.1, a summary of the composition of chromatophores isolated from exponential phase cells grown at modest light intensity, e.g., 500 fc, is presented. This composition is based upon studies from the laboratory of Kaplan and that of the others.

In the strain 2.4.1, we (S. K.) have taken the average outer chromatophore diameter as 55 nm and the inner diameter as 48 nm. It has been estimated that the area occupied by a phospholipid head group is approximately 0.75–0.85 nm² including a correction for the area occupied by proteins in the bilayer (Singer, 1971), then there are approximately 1.27×10^4 phospholipid molecules in the outer leaflet and 0.97×10^4 in the inner leaflet. The overall phospholipid composition is 40–45% phosphatidylethanolamine (PE), 30–35% phosphatidylglycerol (PG), 15–20% phosphatidylcholine (PC) and a trace (1–3%) of cardiolipin (CL). For PE we have determined there is twice as much on the cytoplasmic face of the bilayer as on the periplasmic face. It is interesting to note that in another common strain of *Rp. sphaeroides*, strain 2.4.7, the phospholipid composition is 30–35% PE, 30–35% PG, 10–15% PC, and 15–25% of a recently identified acidic phospholipid, *N*-acylphosphatidylserine* (NAPS; Donohue *et al.*, 1982). There are a variety of phospholipids present in the photosynthetic bacteria, and this topic has been reviewed elsewhere (Oelze and Drews, 1972; Kenyon, 1978; Niederman and Gibson, 1978).

It is estimated that one membrane-bound BChl molecule occupies an average volume of approximately 1×10^{-17} liters, yielding 3×10^3 BChl per chromatophore given the dimensions provided earlier. The total mass of phospholipid present is calculated to be 2.84×10^{-17} g, and with an average protein-to-phospholipid ratio of 3.2 : 1.0 (w/w), the chromatophore contains 9.0×10^{-17} g protein. Therefore, for cells grown at 500 fc, the specific BChl content of the isolated chromatophores is 50 µg BChl per milligram of protein, a value very similar to what is actually found for cells grown at 500 fc. Similarly, the amount of BChl is approximately 3–4% of total chromatophore mass (w/w).

If we assume the mass of a RC complex to be 100 kD and 8% of the total protein is RC protein, as determined from the fraction of RC polypeptide labeling relative to total polypeptide labeling, then the chro-

*It has very recently been determined that all strains of *Rp. sphaeroides* examined possess low levels (~ 0.7%) of NAPS as a fraction of their total phospholipid. However, certain strains, e.g., 2.4.7, are able to accumulate NAPS in excess of 30% of their total cellular phospholipids in response to Tris addition to a minimal growth medium. Other strains, e.g., 2.4.1, do not respond to the presence of Tris.

matophore contains approximately 42 RC complexes. With 42 RC complexes per chromatophore we calculate 500 LH(I) complexes (Aagaard and Sistrom, 1972) amounting to 2.28×10^{-17} g of LH(I) protein at a mass of 1.37 kD. If we assume 2 BChl per 2 LH(I) polypeptides [2 BChl: 2 polypeptides equals an LH(I) complex] the remaining 1750 BChl molecules would reside in 580 LH(II) complexes amounting to 1.84×10^{-17} g of LH(II) protein with a mass of 0.95 kD per polypeptide. We assume 3 BChl per 2 LH(II) polypeptides. The total LH protein is between 40 and 50% of the total chromatophore protein. This is a reasonable expectation for cells grown at 500 fc. The chromatophore would also contain 1×10^3 carotenoids and $\sim 1 \times 10^3$ UQ molecules. We assume a ratio of 25 UQs per RC.

Based upon our observations that at 500 fc approximately 35% of the cellular phospholipid resides in the PMS, we can further calculate that there are approximately 5.5×10^2 chromatophore equivalents per cell giving between 2.1×10^4 to 2.3×10^4 RC complexes per cell, in good agreement with the value obtained by Aagaard and Sistrom (1972). Finally, there would be approximately one photosynthetic unit per 200 nm² surface of PMS.

On SDS gels, one can conservatively recognize 30–35 polypeptides, and in two-dimensional gels approximately 50–55 individual polypeptides are observed by radioautography. In only a few instances has it been possible to identify a particular polypeptide with a particular function (see Section II,D). Finally, it is necessary to reiterate that, for proteins only weakly bound to the PMS in situ, we have the problem of designating whether these are chromatophore proteins or not.

D. Structural Organization of Functional Membrane Complexes

1. REACTION CENTER PREPARATION

a. Rhodospirillaceae. This topic has been exhaustively reviewed in the past several years (Feher and Okamura, 1977, 1978; Gingras, 1978; Olson and Thornber, 1979; Loach, 1980). As defined by Feher and Okamura (1977), the RC "is the smallest isolated unit capable of performing the primary photochemical act." By virtue of this definition, the RC is defined both functionally, as earlier described, and structurally as an entity capable of isolation and physicochemical characterization. (For details on RCs, see Okamura *et al.*, Chapter 5, this volume.)

A major advance in the isolation of the RC complex was made independently by Reed and Clayton (1968) with strain R-26 of *Rp. sphaeroides* and by Gingras and Jolchine (1969) working with strain G9 of *Rs*.

rubrum, both strains being carotenoid mutants. These investigators used the neutral detergent Triton X-100 to disrupt the chromatophores and yet maintain the functional integrity of the RC complex as revealed by its unique photochemical activity following the destruction of bulk BChl (Clayton, 1963; Kuntz *et al.*, 1964). These early preparations were approximately 1×10^6 in molecular weight, contained phospholipids, Cyts, and other components. Furthermore, the isolation procedures when employed on the wild-type strains were not effective. Why this was so is still not yet clear, but the ultrastructural observation of Lommen and Takemoto (1978b) provide a partial explanation.

Data of Feher and Okamura (1977, 1978), Gingras (1978), Olson and Thornber (1979), and Loach (1980) indicated that the choice of detergent and the concentration employed for the initial disruption of the chromatophores is critical to the success of the isolation of an active unit of minimal mass.

The detergents currently used are LDAO, SDS, Triton X-100, Brij, and CTAB; the most extensively used of these is LDAO. Invariably, solubilization of the RC complex is followed by differential centrifugation, and in some instances, ammonium sulfate precipitation and/or ion exchange chromatography, gel filtration, or extraction from Celite. The particular approach depends upon the species and the strain in question.

The best studied RC complex is that prepared from *Rp. sphaeroides* R-26 (Clayton and Haselkorn, 1972; Okamura *et al.*, 1974). Chromatophores are suspended in Tris buffer at 4°C, and LDAO is added to a final concentration of 1.2%. Following differential centrifugation, the supernatant is brought to room temperature and solid ammonium sulfate added. The floating pellet (due to detergent binding) is removed and resuspended in Tris buffer. Additional RC can be removed from the supernatant by a second 0.4% LDAO treatment and combined with the former pellet. After standing, the mixture is clarified by centrifugation and the supernatant is added to Celite, which is extracted with a final concentration of 25% ammonium sulfate made 0.1% with respect to LDAO. This process is repeated until the washings are colorless. The RC is ultimately eluted from the Celite employing a decreasing ammonium sulfate gradient in Tris buffer containing 0.1% LDAO. Ammonium sulfate is removed by dialysis, and the RC preparation is eluted from a DEAE column with a solution of NaCl containing 0.1% LDAO. Following dialysis, the RCs are stored at 4°C in buffer containing 0.25% LDAO. The DEAE fractionation can be repeated if necessary. RC has been purified from wild-type strain Y by Rivas *et al.* (1980), after the method of Jolchine and Reiss-Husson (1974), who employed 0.25% LDAO and procedures otherwise similar to those of Okamura *et al.* (1974).

Vadeboncoeur *et al.* (1979b) purified the RC from wild-type *Rp. sphaeroides* 2.4.1. These authors employed 0.25% LDAO for the initial extraction and then lowered the concentration to 0.1% prior to differential centrifugation. Ammonium sulfate fractionation was followed by filtration on filter paper and resuspension in buffer with 0.1% LDAO. Following dialysis the sample was fractionated on DEAE equilibrated with buffer containing 0.1% LDAO. The RC was eluted with 125 mM NaCl and dialyzed against buffer containing 0.05% LDAO and 1 mM EDTA. Final purification was achieved by molecular sieve chromatography over Sepharose 6B.

Reaction centers have also been prepared using LDAO from the carotenoidless mutant *Ala*⁺ of *Rp. capsulata* by Prince and Crofts (1973) and Nieth *et al.* (1975), who employed the method of Clayton and Wang (1971).

Vadeboncoeur *et al.* (1979a) published methods for the isolation of RC from both wild-type and the G-9 carotenoidless mutant of *Rs. rubrum*. For wild type, these investigators used a modification of Noël *et al.* (1972). Nishi *et al.* (1979), employing cholate-deoxycholate extraction of *Rs. rubrum* chromatophores, prepared an RC preparation similar but not identical to those reported earlier.

b. Bacteriochlorophyll *b* Containing Species. For the BChl *b*-containing species, *Rp. viridis* and *Th. pfennigii*, modifications of the LDAO extraction procedures described earlier have been employed. For *Rp. viridis*, a modification of the procedure of Pucheu *et al.* (1976) was successfully employed by Thornber *et al.* (1978a). The isolated RC have firmly bound Cyt *c* unlike those described earlier (see this section). For *Th. pfennigii*, the preparation has not yet been satisfactorily resolved from contaminating materials.

c. Chromatiaceae. For the isolation of RC from *Chr. vinosum*, several alternative methods are available. Lin and Thornber (1975), employing either wild-type or a carotenoidless strain, extracted chromatophores with 1% LDAO. Solubilized material was fractionated over hydroxylapatite, and the RC was precipitated from the eluate with ammonium sulfate. Following resuspension, the RC were chromatographed on Sepharose-6B. Romijn and Ames (1977) began their RC isolation from *Chromatium* with "AUT-particles" (Loach *et al.*, 1970) involving the treatment of chromatophores with alkaline-urea-Triton X-100. The particles were extracted with cold 90% acetone removing most of the bulk BChl. Finally, hydroxylapatite chromatography was used to obtain RC particles. Tiede *et al.* (1978), starting with a Triton X-100 subchromatophore particle, removed bulk BChl and carotenoids to generate an RC complex.

d. Chlorobiaceae. For the green bacteria, the isolation of the RC is quite complicated, and it is as yet uncertain as to whether or not this goal has been achieved, despite the considerable progress already made. *Chl. limicola f. thiosulfatophilum* was the source for the preparation of complex I (Fowler *et al.*, 1971; Olson *et al.*, 1973), which consists primarily of unit membrane vesicles (Olson *et al.*, 1977). Complex II (Olson *et al.*, 1976) can be prepared from complex I by treatment with 2 M guanidine·HCl followed by Sepharose 4B chromatography and is enriched in primary photochemical activity relative to complex I, although the activity is low (Whitten *et al.*, 1979). Swarthoff and Amesz (1979) employed *Prosthecochloris aestuarii* 2K to prepare a RC complex of considerable activity, and more highly resolved than the complex II reported earlier. A complex I preparation was treated with 1% Triton X-100, diluted, and applied to a sucrose gradient containing 0.05% Triton X-100. Of the three pigmented fractions, that banding at the 40–50% interface was removed and referred to as the photosystem–protein complex and has a particle weight of 600 kD. This fraction was further treated by centrifugation over a step sucrose gradient in which the 30% layer contained guanidine·HCl. The band at the 40–50% interface contained RC activity. This fraction has a particle weight of 350 kD and is lacking in antenna BChl *a*-protein.

Before proceeding to an analysis of the RC complexes, i.e., their composition, stoichiometry, and organization, it is worthwhile mentioning that Loach and co-workers (Hall *et al.*, 1973; Loach, 1980) have made considerable effort in the isolation of the photoreceptor complex (PRC) preparations, which involve the use of alkaline–urea–Triton X-100 extraction of chromatophores. Such complexes are quite large and have in addition to RC activity, carotenoids and bulk BChl–protein complexes.

2. REACTION CENTER COMPOSITION AND STRUCTURE

a. Rhodospirillaceae. The RC derived from *Rp. sphaeroides* R-26 (Okamura *et al.*, 1974) has been the most extensively studied RC preparation. Recent detailed studies on the physicochemical properties of R-26 and wild-type *Rp. sphaeroides* RC reveal that the RC are present as monomers with a particle weight of approximately 80 kD. Vadeboncoeur *et al.* (1979b) obtained a molecular value of 87 kD for the intact RC. The RC consists of three separable polypeptide chains, designated L (light), M (medium), and H (heavy) with subunit molecular weights on SDS-PAGE of 21, 24, and 28 kD, respectively (Feher and Okamura, 1977); these values have been recently revised to 24, 28, and 32 kD by Feher. The H subunit is easily dissociable and not required for photochemical activity (Feher and Okamura, 1978). The intact RC contains

4 BChl and 2 bacteriopheophytin (Bph) (Reed and Mayne, 1971; Straley *et al.*, 1973). Removal of the H subunit does not result in the loss of tetrapyrrole binding. The RC also contains two UQs, one easily removed and the other more tightly bound and apparently interacting with ferrous ion (Feher, 1971; Cogdell *et al.*, 1974; Okamura *et al.*, 1975; Tiede *et al.*, 1978). The binding site of the primary quinone is apparently the M subunit or within 5 Å of the M subunit (Marinetti *et al.*, 1979). However, interaction with the L subunit cannot be eliminated. Since this primary quinone is strongly coupled to the Fe^{2+} of the RC (Feher and Okamura, 1978), we can assume that these components interact strongly with and are in close relationship to the M and the L subunits of the RC. Furthermore, other results (Cogdell *et al.*, 1976) indicate that the RC from 2.4.1 contains a single molecule of spheroidene, which is bound into the L and M subunits. A similar observation was made earlier for strain Y. However, the location of the carotenoid was estimated to be on the periphery of the BChl complex (Jolchine and Reiss-Husson, 1975) and energy transfer from the carotenoid to BChl is possible with an efficiency of 80%. Agalidis *et al.* (1980) added isolated carotenoids back to the R-26-derived RC. Spheroidene or spheroidenone was bound in a ratio of 1 : 1 with the RC, exclusively as the cis isomer, even if the all-trans form was added to the reaction mixture. Given this list of ligands, i.e., 4 BChl, 2 BPh, 2 UQs, 1 Fe^{2+} , and 1 carotenoid, it is remarkable that the L and M subunits are capable of such an extensive array of interaction. That the environment of the L and M subunits within the membrane is special is best demonstrated by the 2-mercaptoethanol-promoted oligomerization of these polypeptides when present with isolated chromatophores or following the addition of isolated subunits to intact chromatophores (Shepherd and Kaplan, 1978). Support comes from the work of Kendall-Tobias (1980). It was determined that isopropanol was just as effective as 2-mercaptoethanol. Finally, these polypeptides are extremely hydrophobic integral membrane proteins (Feher and Okamura, 1977), with the L and M subunits containing approximately 70% apolar residues (Olson and Thornber, 1979).

The observations made to date with LDAO-derived RC from *Rp. capsulata* (Prince and Crofts, 1973; Nieth *et al.*, 1975) indicate the presence of three polypeptides with molecular weights of 28, 24, and 20.5 kD in a molar ratio of 1 : 1 : 1. The smaller two subunits are responsible for pigment binding and can be readily dissociated from the larger subunit.

The RC isolated from *Rs. rubrum* (Vadeboncoeur *et al.*, 1979a,b) when in solution was found to consist of a photoreactive dimer and a free polypeptide. The dimer molecular weight is 60 kD and corresponds to the L and M subunits of *Rp. sphaeroides*, and together with the H subunit,

the molecular weight of the complex is 90 kD. The RC is 90% protein, 0.6% pigment, and contains small amounts of phospholipid but no Cyt. The amino acid composition, like that for *Rp. sphaeroides*, is 65% apolar amino acids. The RC has at least one UQ and one iron atom. The SDS-PAGE profile of the individual polypeptide subunits yields apparent molecular values of 30.5, 24.5, and 21.0 kD. The pigment composition is found to consist of 4 BChl, 2 BPh, 1 spirilloxanthin (van der Rest and Gingras, 1974) in wild-type, and no carotenoid in preparations from the G-9 mutant. Antisera prepared against the various RC show no cross-reactivity among *Rp. sphaeroides*, *Rp. capsulata*, and *Rs. rubrum*. Boucher *et al.* (1977) also demonstrated that the RC isolated from the G-9 carotenoidless strain of *Rs. rubrum* can bind 1 mole of spirilloxanthin per mole of RC. Although other carotenoids will bind into the RC, only spirilloxanthin and sphaeroidene provide a photoprotection efficiency of 1.0 for the RC-BChl. Snozzi and Bachofen (1979) suggest that the phospholipids associated with the isolated RC from *Rs. rubrum* are not representative of the bulk chromatophore phospholipid composition with diphosphatidylglycerol being enriched in the complex. They suggest that as the phospholipid concentration within the isolated RC is decreased, the instability of the complex increases (see also Kendall-Tobias, 1980). The RC complex isolated by Nishi *et al.* (1979) had in addition to the L, H, and M protein subunits, a 10 kD protein subunit. They further reported the isolation of UQ-10 protein complex of mass 11 kD, which, when added back to their RC complex, results in the light-induced oxidation of reduced Cyt c_2 .

Finally, a photosynthetically competent revertant of a photosynthetic minus mutant of *Rs. rubrum* (Picorel *et al.*, 1977) has been isolated and, although possessing the special photoactive [BChl]₂ dimer, it is missing the P800 species associated with the wild-type RC. Investigation of the composition and structure of mutant F24.1 would be useful in determining the role of the other BChl species of the RC.

b. Other Reaction Center Preparations. Clayton and Clayton (1978) observed that the RC isolated from *Rp. gelatinosa* contains only two protein subunits with molecular values of 25 and 33 kD. Because of the ease with which the H subunit can be lost (see earlier), it is premature to conclude that an additional protein subunit is not present in situ.

The composition and structure of the RC isolated from the BChl *b* containing *Rp. viridis* is not well resolved. There appears to be at least four protein subunits with molecular weights of 45, 37, 29, and 23 kD. The RC contains per P960, two Bph *b*, 2 Cyt *c-558*, and 2 Cyt *c-553*, and a menaquinone-like species (Pucheu *et al.*, 1976; Trosper *et al.*, 1977;

Thornber *et al.*, 1978a). The interaction of a semiquinone-Fe complex has been reported, although its precise identity and location is unknown.

Like the *Rp. viridis* RC, the RC preparation from *Chr. vinosum* contains two pairs of both low potential (*c*-553) and high potential (*c*-555) Cyts (Tiede *et al.*, 1978). The RC contains what is believed to be menaquinone, BChl, Bph, and a carotenoid resembling spirilloxanthin (Romijn and Amesz, 1977). Five polypeptides have been observed (Lin and Thornber, 1975) in LDAO prepared RC with three having molecular weights of 300, 270, and 220 kD as well as two additional species (Halsey and Byers, 1975; Rutherford and Evans, 1979).

There has been very little reliable data on the structure and organization of the RC from the Chlorobiaceae. However, the experiments of Swarthoff and Amesz (1979) have shed light on this subject. RC preparations of approximately 350 kD have been isolated; they contain two LH BChl *a*-protein complexes per RC. These preparations contain many polypeptides whose masses are 46, 45, 43, 36, 30, and 22 kD. BChl *a* and Bph *a* are present as well as a pair of low potential Cyt *c*.

3. LIGHT-HARVESTING COMPLEXES

Although the bulk (20-fold or greater) of the BChl associated with the PMS of the photosynthetic bacteria exists as BChl-protein complexes, except in the case of the water soluble BChl *a*-protein complex from the green bacteria (Sybesma and Olson, 1963), these complexes are not as well-defined as the previously discussed RC complexes (see Thornber *et al.*, 1978b for a review). These functional BChl-protein complexes can be identified *in situ* by virtue of their unique absorption spectra and circular dichroism spectra. The spectra reflect specific BChl-protein interactions as well as protein-protein and BChl-BChl interactions. As such, they can be used, as in the case of the RC complex, to follow the isolation of the smallest functional and structural entities able to project these spectral properties. A scheme for the identification and isolation of such complexes has been presented by Cogdell and Thornber (1979). They have divided the LH-BChl spectra into three general groups (excepting the water-soluble complex from the green bacteria). The first group has one kind of complex designated B870-B890 with *Rs. rubrum* a prototype. The second group represented by *Rp. sphaeroides* has the B800, B850, and B870-B890 spectral forms. The last group, represented by *Chr. vinosum*, has in addition to the B800, B850, and B870-B890 forms, other BChl-protein species absorbing maximally at 820 nm. These complexes invariably have associated with them carotenoids specific for the organism under investigation.

The basic rationale for the isolation of spectrally competent LH com-

plexes is not too dissimilar from the protocols described earlier for active RC complexes. Following the isolation of chromatophores, these are disrupted by the use of detergents. The nature of the detergent, its concentration, buffer system, and pH, must be determined for each individual strain and spectral component. Once disrupted, the particular LH complex can be fractionated using one or a combination of the methods previously described such as: differential and gradient centrifugation, ammonium sulfate fractionation, molecular sieve and adsorption chromatography, and polyacrylamide or isoelectric electrophoresis. It is likely, based upon past experience, that the LH complexes will fractionate as a number of multimeric forms. These forms can most probably be subdivided to some functional complex of minimal molecular size upon additional detergent treatment of the isolated multimer(s). When subject to polyacrylamide gel electrophoresis the complexes display a mass of 100 kD (Thornber, 1970) for the *Chromatium* B800–B850 complex and >100 kD for the B800–B850 complex from *Rp. sphaeroides* (Clayton and Clayton, 1972). The B800–B850 complexes which have been isolated have BChl/carotenoid ratios of approximately 3.00 : 1.00 and the B890 complexes have a ratio of approximately 2.00 : 1.00. Upon SDS-PAGE following heating and reduction, the polypeptides are generally small, e.g., 14 kD or less. Often times the complexes will contain lipid material as well as low level RC contamination, which can usually be removed.

4. STRUCTURE AND ORGANIZATION OF LIGHT-HARVESTING COMPLEXES

A variety of LH spectral forms have been isolated, most notably from *Rp. sphaeroides* (Loach *et al.*, 1970; Clayton and Clayton, 1972; Fraker and Kaplan, 1972), *Rp. sphaeroides* R-26 (Reed *et al.*, 1970; Clayton and Clayton, 1972); *Rs. rubrum* (Garcia *et al.*, 1966a; Loach *et al.*, 1970; van der Rest *et al.*, 1974); *Rp. palustris* (Garcia *et al.*, 1968); *Chr. visonsum* D (Garcia *et al.*, 1966b; Thornber, 1970; Halsey and Byers, 1975); *Th. roseopersicina* (Takacs and Holt, 1971a); and *Rp. viridis* (Thornber *et al.*, 1969; Pucheu *et al.*, 1974; Trosper *et al.*, 1977).

Moskalenko and Erokhin (1978) demonstrated that the B800–B850 complex from *Rp. sphaeroides* as well as LH complexes from several other photosynthetic bacteria contain two polypeptides of masses of 9 and 12 kD by SDS-PAGE. Further, they showed that high molecular weight aggregates of LH complexes could be isolated on SDS-PAGE when the samples are not heated and when applied to the gel (also see Shepherd and Kaplan, 1978). They further revealed that the resolution of these two polypeptides is very dependent upon the gel system employed. This

is also true for LH preparations of *Chr. minutissimum*, *Th. roseopersicina*, *Rp. palustris*, and apparently *Rs. rubrum*.

The resolution of the number and kinds of polypeptides involved in the formation of the LH complex is essential in interpreting the experiments of Cogdell and Crofts (1978) and Sauer and Austin (1978). From studies with wild-type *Rp. sphaeroides* and strains G1C and Ga, Cogdell and Crofts concluded that the smallest functional unit of the B800–B850 pigment–protein complex is 3 BChl and 1 carotenoid, with the latter showing no species selectivity within the complex. Sauer and Austin employing a combination of Triton X-100 and Triton X-100–SDS extraction procedures isolated a B800–B850 complex from *Rp. sphaeroides* 2.4.1 and B855 from mutant R-26. They found that the initial Triton X-100 extracted complexes had particle masses of approximately 400 kD, and when SDS was employed, the particle weight was reduced to approximately 220 kD. Further treatment yielded polypeptide(s) of approximately 10kD. Within these complexes, they found that there was 1.5 BChl per polypeptide of 10 kD for the wild-type complex and one BChl per polypeptide for the R-26 complex. Furthermore, they concluded that the B850 spectral form in wild-type results from the strong interaction of two BChl, one for each of the two 10-kD polypeptides in the complex. The B800 spectral form results from a third BChl, shared between the two polypeptides. In the case of R-26, the B855 spectral species results from the interaction of two BChl on each of two polypeptides, but the third BChl is absent, resulting in the absence of B800. This alteration may result from the fact that either one or both of the low molecular weight polypeptides of the complex is altered. Finally, the isolated complexes contain a considerable fraction, approximately 15% by weight of phospholipid.

Brogie *et al.* (1980) applied the method of Delepelaire and Chua (1979) employing LDS for the solubilization of photosynthetic membranes at low temperatures in order to prepare and electrophoretically separate a series of pigmented, high molecular weight complexes from chromatophores obtained from *Rp. sphaeroides*. Two particular complexes were of interest. One complex contained the B800–B850 spectral form and the other contained the B875 spectral form. The remainder of the complexes were either combinations of these two or combinations of these with RC complex. The B800–B850 complex contains three BChl and a single carotenoid. SDS-PAGE analysis of the polypeptide profiles of these spectral forms reveals the B800–B850 to contain a 10 and an 8 kD polypeptide. The B875 contains a 12 and an 8 kD polypeptide. It should be pointed out that although these were the major polypeptides present, there were a number of other polypeptides, particularly in the

B875 preparation. Likewise, it was not possible to compare the stoichiometry of the major polypeptides to one another. However, these results are exciting and in addition to describing what might be the basic substructure of both the B875 and B800–B850 complexes of *Rp. sphaeroides*, they also reveal the presence of numerous multimeric forms of these basic LH units, particularly, as they might relate to one another within the PMS.

Our (S. K.) laboratory has taken a somewhat different approach to this same problem. The chromatophores of *Rp. sphaeroides* have been completely solubilized without the use of detergents (Cohen and Kaplan, 1981a,b) and three polypeptides, which may be homologous to those described by Broglie *et al.* (1980), have been purified. The assays for these polypeptides have been: (1) their abundance; and (2) their migration in SDS-PAGE. Of the three polypeptides, one has a molecular value of 13.7 kD by both Ferguson plots (Hedrick and Smith, 1968) and ultracentrifugation (Bothwell *et al.*, 1978). This polypeptide has an NH₂-terminal L-aspartic acid. The other two polypeptides have an identical molecular value of 9.5 kD and blocked NH₂-termini. However, these two polypeptides are immunochemically unrelated. The two smaller polypeptides have isoelectric points of approximately 6.0 and 5.4, and the large polypeptide has an isoelectric point of approximately 5.0. Migration in SDS-PAGE yields apparent molecular values of 12, 10, and 8 kD for the large and two small polypeptides, respectively. Together, these three polypeptides account for 40–50% of the chromatophore protein. During the early stages of purification, there are between 6–10 additional polypeptides of different isoelectric points, but whose migration in SDS-PAGE is identical to the three major species, i.e., approximately in the 10 kD range. These minor species, separately, do not account for more than a few percentage each of the individual major species that have been purified. However, cumulatively these minor species make up 3–6% of the total chromatophore protein. Some of these polypeptides may reflect microheterogeneity of the three major polypeptides that have been purified. When the organic solvent extraction technique of Tonn *et al.* (1977) is employed, selective extraction of the two 9.5 kD polypeptides, together with at least 8–12 additional polypeptides, occurs. Many of these additional polypeptides are identical, by isoelectric focusing, to the minor species that are observed employing Kaplan's purification method. The 13.7-kD species is not extractable by chloroform–methanol (1:1). Finally, antisera prepared against these individual polypeptides are active against the appropriate BChl–protein complexes.

Feick and Drews (1978, 1979) used a combination of SDS or LDAO extraction procedures to isolate B875 and B800–B850 complexes from

Rp. capsulata. The B875 complex is isolated from mutant strain Ala⁺ lacking carotenoids and B800–B850 complex. The latter complex was isolated from mutant strain Y5 lacking RC and the B875 complex. The B875 complex contains one polypeptide by SDS-PAGE of 12 kD. It has associated with it at least one and possibly two BChl. The B800–B850 complex has three polypeptides of 14, 10, and 8 kD and three BChl plus carotenoid. The three BChl are associated only with the two smaller subunits. These proteins are not as hydrophobic as other LH- polypeptides, which have been reported (Fraker and Kaplan, 1972; Tonn *et al.*, 1977; Sauer and Austin, 1978).

Cuendet and Zuber (1977) and Cuendet *et al.* (1978) have isolated a BChl-protein-lipid complex (LH complex) from the carotenoidless mutant, G-9, of *Rs. rubrum*. The complex has a molecular value of 68 kD and is 66% protein, 29% phospholipid, and 5% BChl on a dry-weight basis. SDS-PAGE analysis reveals the presence of a single polypeptide of 14 kD. The protein stains positively with the periodic acid-Schiff reagent suggesting that it is a glycoprotein. It is readily extractable from the complex or RC-depleted chromatophores with chloroform-methanol (see Tonn *et al.*, 1977) and is approximately 50% of the chromatophore protein. Tonn *et al.* (1977) revealed that this protein has a blocked NH₂-terminus and COOH-terminal glycine. Their molecular weight estimates differ from that of Cuendet and Züber (1977). The protein has an isoelectric point of 7.1, and they confirm the presence of 1.5 g of carbohydrate per 100 g of protein. It is estimated that there are between 3–7 BChl and 1–2 carotenoids per organic solvent-extractable polypeptide. Organic solvent extractable polypeptides have also been isolated from *Chromatium* (Halsey and Byers, 1975). However, these polypeptides are more variable in size. It has also been determined that this protein from *Rs. rubrum* is primarily in the α -helical form (Kopp *et al.*, 1979), and if it is the same protein isolated by Miyake *et al.* (1978), it binds 3–4 times the level of SDS normally associated with SDS protein binding. An additional pigment-protein complex was isolated from *Rs. rubrum* (Schwenker and Gingras, 1973; Schwenker *et al.*, 1974) and found to be 10% of the chromatophore protein. This complex contains carotenoid (spirilloxanthin) noncovalently bound to a 11 kD polypeptide. This protein contains carbohydrate and L-tyrosine, but neither L-histidine nor L-cysteine, making it quite different from the BChl-protein complex (Tonn *et al.*, 1977). A similar protein has not been isolated from *Rp. sphaeroides*.

The best studied LH-BChl-protein complex is that isolated from the green bacterium *Prosthecochloris aestuarii* (Matthews *et al.*, 1979), and it can be readily distinguished from previously discussed BChl-protein complexes due to its solubility in water. The complex consists of three identical polypeptide chains and 21 BChl for a molecular value of 150

kD. Each subunit of 39 kD contains 7 BChl. The three chains are closely arranged around a threefold axis of symmetry. Each chain represents an extensive β -sheet, and the chains are arranged relative to one another such that the complex forms an amphipathic shell with the BChl on the inside and aqueous environment on the outside. The phytol side chains of the 7 BChl, within one polypeptide chain, interact extensively but the head groups do not. However, it has been concluded the 7 BChl of one subunit act as a single unit when considering the delocalization of excitation energy. For previous reviews see Olson (1978) and Pierson and Castenholz (1978).

5. COUPLING FACTOR

The most extensively studied ATPase of the photosynthetic bacteria is that from *Rs. rubrum*. For further details on the structure and function of ATPases, see McCarty and Carmeli, Chapter 14, this volume. Several research groups have reported the isolation, composition, and organization of both the F_1 and F_0F_1 complexes from this organism. Johansson and Baltscheffsky (1975) and Lücke and Klemme (1976) reported the isolation of the purified F_1 portion of the ATPase. The mass of the complex was approximately 350 kD and it contains five subunits of 54 (α), 50 (β), 32 (γ), 13 (δ), and 7.5 (ϵ) kD.

The F_0F_1 portions of the chromatophore-derived ATPase from *Rs. rubrum* have also been reported. The presence of the F_0 portion of the complex together with the F_1 portion can be determined by oligomycin sensitivity and DCCD sensitivity of the total complex. Three different preparations have been isolated and characterized (Bengis-Garber and Gromet-Elhanan, 1979; Müller and Baltscheffsky, 1979; Oren and Gromet-Elhanan, 1979; Schneider *et al.*, 1979). The preparation by Schneider *et al.* (1979) contains 14 polypeptide chains, yielding a mass for the complex of nearly 500 kD. The activity is not completely inhibited by DCCD. The original preparation of Oren and Gromet-Elhanan (1979) contains 13 subunits, but another preparation contains 8 subunits (Bengis-Garber and Gromet-Elhanan, 1979) and is almost completely inhibited by oligomycin or DCCD, when the complex is incorporated into liposomes. The preparation of Müller and Baltscheffsky (1979) contains 9 subunits and is inhibited by oligomycin.

All of the purified complexes are stimulated by either Mg^{2+} or Ca^{2+} . Soe *et al.* (1978) demonstrated the conversion of the Ca^{2+} -activated form to the Mg^{2+} -activated form by the inclusion of C16 and/or C18 fatty acids in the incubation mixture. However, this enzyme is purified from acetone powders of chromatophores whereas the other preparations are purified from aqueous extracts of chromatophores. It would be

of interest to determine if these preparations require trace amounts of specific fatty acids for activity.

With the exception of the F_1 portion of the coupling factor from *Chromatium* (Gepshtein and Carmeli, 1978) coupling factor preparations from other photosynthetic bacteria have not been purified or as well characterized as the *Rs. rubrum* complex and these will not be discussed here.

E. Topological and Vectorial Organization of the Photosynthetic Membrane and Its Components

1. PHOSPHOLIPID AND PROTEIN DISTRIBUTION

In an earlier section, evidence was provided that strongly indicates that the PMS of the Rhodospirillaceae and Chromatiaceae are continuous with the cell membrane. Evidence was also presented that demonstrated that the overall composition, both qualitative and quantitative, of these "domains" within an otherwise continuous membrane, differs substantially, particularly when care is taken to separate these domains. Whether or not the last traces of the PMS in the envelope fraction, isolated from phototrophically growing cells, represents contamination or specific insertions of photosynthetic units within the continuum of the CM remains to be determined. Further support for the continuity of these "domains" within a single bilayer is provided by Shimada and Murata (1977). Employing whole cells of *Chr. vinosum*, they are able to demonstrate that the PE of isolated chromatophores is accessible from the cell exterior by use of the chemical modifying agent TNBS. These results can best be interpreted as demonstrating the continuity of the periplasmic space within the interior of the chromatophore. Furthermore, their results indicate that PE is equally distributed between the two leaflets of the bilayer. We (S. K.) have performed similar experiments with *Rp. sphaeroides*, and although we find the distribution of PE in the chromatophores to be approximately 1:2, periplasmic face to cytoplasmic face, there is no doubt that the periplasmic face is completely accessible from outside the cell. If the PMS were inaccessible to the periplasm or existed as chromatophore vesicles in situ, then the results obtained using TNBS would be inexplicable.

There is considerable evidence demonstrating that the protein to phospholipid ratio (w/w) of the chromatophores is approximately 3.2:1 (see earlier). As described later, this ratio can be as low as 2:1 and as high as 5:1, at least for *Rp. sphaeroides*. In any case, the PMS is protein rich, and this has very significant implications as to the structure and

function of the PMS. Sauer (1978) has taken this into account and suggests that the PMS be considered a "pebble-mosaic membrane" model (Sauer, 1975) in contrast to the "fluid-mosaic membrane" model of Singer and Nicolson (1972). In the former model, the membrane is composed of a mosaic of functional and structural units. These units, relatively large in size, are not freely mobile in the plane of the membrane. Support for a lack of "fluidity" within the chromatophores of *Rp. sphaeroides* and the large amount of "boundary" lipid comes from work by Fraley *et al.* (1978a) and by Birrell *et al.* (1978). Fraley *et al.* (1978a) employed the fluorescent dye α -parinaric acid in order to measure the fluorescence polarization of the dye in the chromatophores of the carotenoidless mutant R-26. These investigators estimate that approximately 62% of the probe is in the "boundary" form. Similar measurements were made by Birrell *et al.* (1978) using lipid spin-labels, which were followed by ESR analyses, a method quite different from that employed by Fraley *et al.* (1978b). Birrell *et al.* (1978) estimate that 59% of the probe is in the "boundary" form. The agreement between these observations is not only remarkable, but also demonstrates the "rigidity" of the chromatophore bilayer in *Rp. sphaeroides*. It was further estimated that as the amount of LH complex increases in the membrane, the amount of free probe decreases. This will be discussed later in more detail.

2. TOPOLOGICAL ORGANIZATION

With respect to the general organizational arrangements of the PMS, major uncertainty exists, although there has been increased interest in this area of late. Takemoto and Bachman (1979) employed isolated chromatophores (inside-out orientation), intact spheroplasts and spheroplast-derived vesicles (containing both CM and ICM) of right-side-out orientation in order to investigate the localization of a number of components and activities associated with the CM and PMS. They concluded that the ATPase, SDH, L-LDH, and NADH dehydrogenase activities are localized on the outside of isolated chromatophores. For ATPase and SDH, these activities are localized on the inside of isolated spheroplast-derived vesicles. These data are in accord with previously described results, but they serve the added need of a series of biochemical markers, which can be used to assess the orientation of any preparation of chromatophores and spheroplast-derived vesicles from phototrophically grown cells. Unfortunately, this approach, as well as those to be described, suffers from the fact that many of the activities in question are found in both CM (isolated from chemotrophically grown cells) and isolated chromatophores, and as a result, most measurements represent

differences between the levels of a common or shared activity or component. What is required are activities or components unique to the CM, even in phototrophically growing cells, as well as a method for the preparation and isolation of chromatophores of right-side-out orientation.

Oelze (1978) employed a combination of protease digestion and enzyme-catalyzed iodination for localization studies of isolated chromatophores prepared by either French Press or osmotic lysis of spheroplasts of *Rs. rubrum*. Chromatophores prepared by either method gave similar results. The heavy subunit of SDH, portions of the F_1 -ATPase complex, the H subunit of the RC, and the protein portion of the LH complex have some segment of their structure exposed at the outer surface of the chromatophore by either iodination or protease digestion. It was further revealed that a polypeptide of 41 kD is also exposed at the outer surface of the chromatophore. This protein is suggested to be equivalent to the major OM protein, although no evidence is cited to confirm this identification except migration in SDS-PAGE. Zürrer *et al.* (1977) also observed the iodination of the H subunit of the RC in isolated chromatophores. From pronase treatment of *Rp. sphaeroides* chromatophores, Kaplan and co-workers observed an alteration in molecular weight of the H subunit of the RC complex, a slight but noticeable diminution in LH-protein, but most striking is the almost total alteration, but not disappearance, of, the banding pattern in the region of the SDS-PAGE gel above 30 kD. Pronase is a much more severe protease than chymotrypsin used by Oelze. Whereas Oelze used very high ratios of enzyme to chromatophore protein, Kaplan and his group use less than 2% self-digested pronase per milligram chromatophore protein. Using radioactively labeled chromatophores, it is estimated that 30% of the total protein of the chromatophore is removed following pronase digestion. Similar results were obtained by Shimada and Murata (1977). Because of these studies we concluded that a major portion of the chromatophore protein exists on the outer surface. The remainder of the polypeptide material is either within the bilayer or transmembrane. Lactoperoxidase catalyzed iodination of chromatophores supports the studies with pronase.

3. IMMUNOCHEMICAL CHARACTERIZATION

Collins *et al.* (1979) and M. L. P. Collins (personal communication), employed crossed immunoelectrophoresis (CIE) (Owen and Salton, 1977) to investigate the location of chromatophore proteins. Using whole chromatophores, they demonstrated at least 31 immunologic species, 2 of which were identified as NADH and LDH. Antibody against purified RC complex revealed a unique immunoprecipitate, and the

presence of BChl served to identify the LH complex. Extending this approach, together with specific cross-absorption experiments, employing different antigenic species, it was concluded that L-lactate and SDH dehydrogenases, LH complex or a portion thereof, as well as the RC complex are all exposed to the cytoplasmic aspect of the chromatophore membrane. Furthermore, the RC appears to be trans-membrane. Numerous, as yet unidentified, polypeptides either span the membrane or are localized on the periplasmic side. Finally, charge-shift CIE reveals the amphipathic nature of many of the chromatophore proteins as well as the presence of protein species not previously described by this technique. A similar approach has been undertaken by Konings and collaborators (Elferink *et al.*, 1979) who have estimated, by determining the distribution of ATPase, SDH, and NADH dehydrogenase, that at least 75% of their spheroplast derived membrane vesicles are right-side-out and greater than 90% of their chromatophores are inside-out. A total of 52 immunoprecipitates were observed with membrane vesicles and the homologous antibody and 59 precipitates with chromatophores and antichromatophore antibody. Heterologous reactions indicate that the antigenic composition of the membrane vesicles and chromatophores are very similar. This is not unexpected since both the chromatophore and membrane vesicle preparations used as immunogen were isolated as a precipitate from a high speed supernatant of a crude cell extract in the presence of Mg^{2+} . Under these conditions the chromatophore preparation is not less than 10% contaminated with soluble as well as particulate protein (Fraker and Kaplan, 1972). The same is probably true for the membrane vesicle preparation. It is not intended to imply that the chromatophores and membrane vesicles do not share many protein components; in fact, they do share several components. However, the kind of preparation used as immunogen makes the analysis and interpretation of the data more complex.

4. LOCALIZATION OF MEMBRANE COMPONENTS

Although it has been difficult to determine, because of the absence of pure chromatophores of reverse orientation, what components exist on the periplasmic face of the PMS, there is good evidence that the Cyt c_2 from *Rp. sphaeroides* and *Rp. capsulata* are localized on that aspect of the PMS. Prince *et al.* (1975) using antibody against purified Cyt c_2 from *Rp. sphaeroides* and *Rp. capsulata* localized this cytochrome on the periplasmic side of the PMS. A similar localization of Cyt c_2 has been inferred by others (Orlando *et al.*, 1961; Hochman *et al.*, 1975). Because Cyt c_2 is responsible for the reduction of the oxidized special BChl pair of the

RC, we anticipate that this portion of the RC should be situated at or near the periplasmic aspect of the PMS. Similarly, the light-induced uptake of protons by isolated chromatophores mediated by UQ provides evidence that a portion of the RC complex is localized at or near the cytoplasmic aspect of the PMS thus revealing the asymmetric or vectorial relationship of the RC complex and cyclic electron transport chain. Reed *et al.* (1975), using ferritin-antibody conjugates, were able to show that following the removal of the ATPase from isolated chromatophores of R-26, antibody against the RC-complex was able to interact with the chromatophore surface. It was estimated that on the average, one RC exists per 175 nm² membrane surface. Because no reaction is observed with intact spheroplasts, it is further concluded that the RC does not extend to the periplasmic face of the PMS. A similar approach by Feher and Okamura (1977) confirmed and extended the results of Reed *et al.* (1975). This group demonstrated that the H component of the RC was on the chromatophore surface, and the LM components span the membrane and can be identified on the periplasmic face of the PMS. Zürrer *et al.* (1977), employing enzymatic iodination of chromatophores and spheroplasts of *Rs. rubrum* followed by RC isolation, conclude that the H subunit is accessible from the outside of the chromatophore. Neither the L nor M subunit is significantly labeled under any condition. This is also true of the H subunit when approached using spheroplast preparations. Hall *et al.* (1978) employed protease digestion of *Rp. sphaeroides* chromatophores in order to localize the RC subunits. They observed the complete disappearance of the H subunit, thereby extending the evidence regarding its location on the outer surface of the chromatophore. When examining their SDS-PAGE profile of the pronase-treated sample, there is the total absence of the H subunit as well as most polypeptide species above 30 kD. Similar experiments, described earlier, using self-digested or untreated pronase, show that the H subunit is only "clipped." On SDS-PAGE analysis, the H subunit migrates as if it were 1–1.5 kD smaller, thereby suggesting that only a portion of the H subunit is exposed to the outer surface of the chromatophore and that this portion is either the amino or carboxyl end of the molecule. Although we cannot explain the basis for the discrepancy between these results and those of Hall *et al.*, we have observed that following extensive pronase digestion, the chromatophores do not solubilize in the normal manner, and it is possible to obtain SDS-PAGE patterns indential to those observed by Hall *et al.* However, rigorous solubilization procedures, involving heat at 100°C and 5% SDS result in an SDS-PAGE profile revealing the presence of a clipped H subunit. These results suggest to us that the end result of chromatophore solubilization in detergents is deter-

mined by protein–detergent, protein–protein, and protein–lipid interactions. Alteration of the intrinsic interactions such as by protease digestion will affect subsequent extrinsic interactions.

There is additional evidence that a portion, at least, of the LH complex may also be exposed to the outer surface of the chromatophore. Feick and Drews (1979) employed trypsin digestion of chromatophores isolated from mutant Y5 of *Rp. capsulata* possessing only LH(II) and observed the gradual disappearance of the 8 kD polypeptide accompanied by a proportional loss in absorbance at 802 nm. As a result of the TNBS treatment of whole cells and isolated chromatophores of *Chr. vinosum* described earlier, Shimada and Murata (1977) observe the modification of a protein on the chromatophore surface which is ultimately extractable with chloroform–methanol. This protein could not be approached by TNBS from outside the cell. Although this protein was not identified, its behavior in chloroform–methanol is similar to the behavior of the low molecular weight portion of the LH-complex (Tonn *et al.*, 1977).

Therefore, we conclude that the PMS is most likely continuous with the CM, and the interior of the invagination is continuous with the periplasmic space. Cyt c_2 or its functional equivalent is bound at the surface of this face and interacts with one or both smaller subunits of the RC complex, which, in turn, extend through the bilayer, interacting with the H subunit that has a small portion exposed to the cytoplasm. A part of the LH(II) complex is also exposed to the cytoplasmic side of the PMS. The cytoplasmic side of the PMS is rich in exposed protein relative to the periplasmic side of the PMS. Whether or not the L and/or M subunit is exposed at either face is not yet clear since the evidence is conflicting. The large UQ pool, a portion of which must be oriented towards the cytoplasmic face of the PMS, is able to interact with Cyt b , which through Qz is coupled to Cyt c_2 (also consult Fig. 1 in Chapter 2 by Wraight). We do not know if a UQ–protein complex exists within the PMS. At this time, this section of the chain seems less well organized, undoubtedly expressing the inadequacy of our information. The isolation of the Q– b – c_2 oxidoreductase portion of the chain would shed considerable light on this problem.

The organization of the LH complexes relative to both one another and to the RC complex is of intense interest, and an increase in the understanding of the structure of the isolated complexes will indeed facilitate the interpretation of the physicochemical data obtained.

Monger and Parsons (1977) using a variety of *Rp. sphaeroides* strains under several conditions of growth examined BChl singlet interactions

with either the BChl triplet or the carotenoid triplet in order to gain insight into the movement of singlet excitations within the LH complexes. They conclude that singlet excitations could migrate throughout the antenna pool and are rapidly concentrated in the B870 complex. Therefore the B870 complexes are not restricted to a single RC, but can interact with more than one RC. The B800–B850 complexes are peripheral to the B870 complex but in such a way as to facilitate the transfer of excitations. Bolt and Sauer (1979) have oriented LH complexes from *Rp. sphaeroides* and R-26 in polyvinyl alcohol in which the stretching of the substratum induces orientation of the complexes. Spectral analysis of these complexes provides only preliminary information on the orientation of the LH pigments present in the isolated complexes. However, the B800 species present in wild type and absent in R-26 can be easily distinguished from the B850 complex. Furthermore, Rafferty *et al.* (1979) have shown that the two BChl molecules associated with the R-26, LH complex undergo strong exciton coupling. In *Rp. viridis*, Paillotin *et al.* (1979) estimates that the antenna BChl molecular plane is almost perpendicular to the membrane and Abdourakhmanov *et al.* (1979) concluded that the RC complex is oriented in the membrane and lies nearly parallel to the membrane plane. However, the special BChl donor pair in *Rs. rubrum* is nearly perpendicular to the membrane plane, with the plane of each BChl monomer parallel to one another. The primary UQ acceptor is perpendicular to the special pair and is coplanar with the membrane (Hales and Gupta, 1979). Still other approaches are in progress in order to obtain a precise description of not only the orientation of each component of the photochemical unit to the membrane plane, but of each component to one another (Tiede *et al.*, 1978; Frank *et al.*, 1979a,b; Rafferty and Clayton, 1979). (For a complete discussion on the orientation of pigments and complexes, see Breton and Vermeglio, Chapter 4, this volume.)

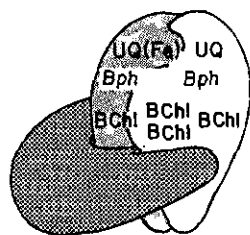

FIG. 2. Hypothetical model of the RCs of photosynthetic bacteria, showing the association of 4 BChl and 2 Bph with 3 peptides and an iron–UQ complex. (Reprinted with kind permission from Sauer, K. (1978). *Acc. Chem. Res.* 11, 257–264. Copyright 1978 American Chemical Society.)

REACTION CENTER

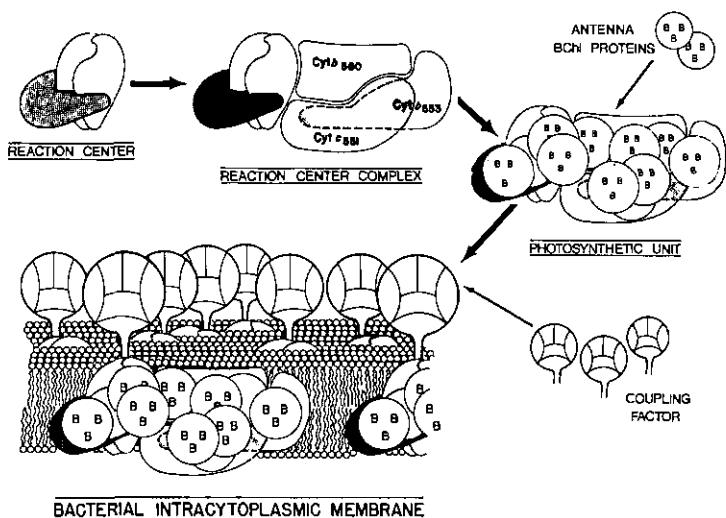

FIG. 3. Model of the assembly of intracytoplasmic membranes of photosynthetic bacteria. Reaction centers (left, top) form complexes with Cyt and, with 12–15 antenna BChl (labeled with 3B's)—proteins attached, make up a basic photosynthetic unit of the active membranes. Insertion of coupling factor protein, involved in phosphorylation, is also shown. The units are assembled with lipids in a two-dimensional sheet that possesses the asymmetry required for ion pumping and electric-field formation. The subscript on Cyt *b* and *c* indicate the wavelength, in nm, of one of their absorption bands. (Reprinted with the kind permission of the American Chemical Society and K. Sauer. From Sauer, 1978.)

Figures 2 and 3 schematically represent an RC complex and a segment of the PMS containing a photosynthetic unit respectively. Although the H subunit depicted as a tongue in Fig. 2 is apparently not required for primary photochemistry, its association with M and L is deemed to be something more than gratuitous. In Fig. 3, the RC complex is shown to interact with a complex of Cyts, which when surrounded by LH complexes forms the intact photosynthetic unit. In general, all of the work cited is in conformity with this model. However, the precise details of the structure of the PMS await the kinds of resolution alluded to earlier.

F. Reconstitution Studies

Experimental evidence is accumulating that demonstrates the ability to reconstitute the whole or portions of the cyclic electron transport chain together with light-driven ATP formation and energy transfer. Jones and Plewis (1974) and Garcia *et al.* (1974, 1975) demonstrated the reconstitution of light-dependent electron transport and photophos-

phorylation. In these systems, RC complexes were added to membrane or envelope fractions derived from photosynthetically incompetent mutants of either *Rp. sphaeroides* or *Rp. capsulata* and the light-dependent reactions monitored.

Hunter and Jones (1979a,b) attempted to optimize the reconstitution procedure and to accurately ascertain the nature of the events taking place. Light-harvesting and/or RC complexes are mixed together with the membranes from aerobically grown cells of a photosynthetic mutant (01) of *Rp. sphaeroides*. The mixture is incubated in the presence of 1% cholate and soybean phospholipid. Membranes are resolved, together with RC and LH complexes, by isopycnic sucrose density-gradient centrifugation. The reconstituted system demonstrates the light-dependent Cyt changes as described for the intact organism. However, the rates of these changes are generally slower than those observed *in vivo*, although significant heterogeneity exists. Electron flow between Cyt *b* and c_2 is slow and the photo-oxidation of Cyt c_2 is biphasic. When membranes derived from strain PM8 are used, electron flow between Cyt *b* and c_2 is fast, but overall, the kinetics are not as satisfactory as when using membranes from strain 01 (it was also possible to measure the energy transfer from LH to RC BChl in these experiments).

A complementary, but different, approach has been developed by Matsuura and Nishimura (1977), who reconstituted proteoliposomes using detergent-solubilized complexes from *Rp. sphaeroides* and soybean phospholipids. An SDS-solubilized chromatophore preparation is fractionated and a fraction containing B800–B850, carotenoids, Cyts, etc., is incorporated into proteoliposomes. Photooxidation of RC and light-induced band shifts of carotenoids were measured, and the effects of valinomycin and K^+ on the carotenoid band shifts were studied; results indicate that the organization within the proteoliposome is the same as in intact cells.

Very recent work by Yen *et al.* (1982), employing the fusion of chromatophore vesicles, opens the possibility for the study of physiological complementation between membrane vesicles derived from mutant organisms.

It seems clear, that as the isolation and characterization of the functional and structural components of the PMS becomes increasingly well defined, *in vitro*, reconstitution experiments of the form described earlier will yield more information on these components.

G. Membrane Biosynthesis

The control of photosynthetic membrane biosynthesis in the photosynthetic bacteria has been reviewed (Oelze and Drews, 1972; Drews,

1978; Kaplan, 1978; Drews and Oelze, 1981) extensively over the past several years and very little can be added to these excellent reviews. (For a complete review of this field, the reader should consult Chapter 5 by I. Ohad and G. Drews in Volume II, also edited by Govindjee (1982).) The discussion here will center about the work in one of the author's (S. K.) laboratory, both published and unpublished. In particular, the implications that this work has on many of the subjects discussed earlier will be brought into focus.

Employing synchronous cell cultures of *Rp. sphaeroides* the steady state biosynthesis of the PMS is followed. In the first series of articles (Fraley *et al.*, 1978a,b; Lueking *et al.*, 1978; Wraight *et al.*, 1978), it was demonstrated unequivocally that the PMS is noncoordinately synthesized. On the one hand, the bulk of the protein, BChl, carotenoids, Cyts are made at a constant rate and continuously inserted into pre-existing PMS. As a result, the accumulation of both RC and LH complexes is continuous throughout the cell cycle. Two enzyme activities, SDH and NADH oxidase, were observed to increase discontinuously during the cell cycle. On the other hand, bulk phospholipid synthesis at the whole cell level was demonstrated to be discontinuous, i.e., stepwise.

Because these earlier studies employed D_2O as a means of following PMS biosynthesis, it was not possible to study intrinsic alterations in chromatophore density. Therefore, a second series of experiments (Fraley *et al.*, 1979a,b) were undertaken in order to monitor intrinsic changes and to more accurately assess the temporal regulation of phospholipid insertion into the PMS. In these studies, we were able to demonstrate that as a result of the discontinuous accumulation of phospholipid into the PMS, together with the continuous insertion of other PMS components, the protein-to-phospholipid ratio of the isolated chromatophores undergoes cyclical increases and decreases coordinate with the cell cycle. These ratios reach a low point of approximately 2.0 : 1.0 following cell division and reach a high point of nearly 5.0 : 1.0 just prior to cell division, i.e., in steady state phototrophic cells the PMS can vary continuously from 67% protein–33% phospholipid to greater than 83% protein–17% phospholipid. Expressed another way, this variation is from a low of 26 RC complexes per chromatophore to a high of 66 RC complexes per chromatophore or from one RC complex per 320 nm² to one RC complex per 130 nm². When considering these results, in light of the model presented by Sauer in Fig. 3, the “islands” of photochemical units in a “sea” of lipid progressively become “lakes” of lipid in a “continent” of photochemical units. These changes, in addition to being monitored by protein-to-phospholipid ratio, were also monitored by the actual change in density of the isolated chromatophores resulting from

their changing compositions. The maximum intrinsic density change is greater than 0.01 g/cm^3 . Further analysis of the physical state of the phospholipids present in chromatophores composed of low through high protein-to-phospholipid ratios was undertaken with the use of α -parinaric acid as previously described for asynchronously growing cells (Fraleley *et al.*, 1978a). The data show clearly that the magnitude of the polarization change in the probe is quite substantial and equivalent to what would be observed for at least a 20°C change in temperature. In practical terms, the phospholipids of the PMS become less mobile, to the point where nearly all phospholipid is in the "boundary" form. The membrane is extremely rigid at this point. Because the decrease in membrane fluidity is coincident with the step in the activity profile of SDH and NADH oxidase, it is tempting to consider the possibility that the activity of these enzyme systems are sensitive indicators of the bulk membrane viscosity.

These results may have significant implications relative to some of the work described earlier. The chromatophores routinely isolated from *Rp. sphaeroides* are clearly heterogeneous in their bulk protein to phospholipid composition and although this may present no problem for many routine studies, e.g., RC, LH, and enzyme isolation, it may be a significant problem when considering measurements on enzyme activity, and photophosphorylation rates. Further, structural studies such as freeze fracture of vesicles or PMS, particle density, topology of membrane components, nearest-neighbor analyses, protein-protein or protein-phospholipid interactions, and chromatophore orientation may vary dramatically depending upon the protein-to-phospholipid composition of the chromatophores.

Many of the studies so far undertaken to assess the bilayer distribution of various membrane components, such as the H subunit of the RC complex, have been qualitative. Scant attention has been paid to the stoichiometry of the reactions being studied. For a chromatophore population representing a continuum of composition and structure, such studies may only approximate, at least, the *in situ* state. Because our experiments have only been performed with *Rp. sphaeroides* strains 2.4.1 and 2.4.7 or their derivatives, we are not in a position to generalize for other photosynthetic bacteria.

From our studies cited earlier, we have also learned that it is the accumulation of phospholipid into the PMS that is being regulated in a cell cycle specific fashion. Cain *et al.* (1981) provided us with the answer as to the mechanism of phospholipid accumulation. We have demonstrated that despite the physical continuity of CM and PMS in *Rp. sphaeroides*, these two membrane systems are, for all practical purposes,

separable domains. Phospholipid synthesis, although taking place at the whole cell level throughout the cell cycle, does not find its way into the PMS until the time of cell division. Therefore, we can conclude that the free movement of phospholipid in the plane of the bilayer from its site of synthesis, presumably the cell membrane, into the PMS is restricted. We can only speculate at this time as to the mechanism of restriction. However, at cell division, when phospholipid is accumulated into the PMS, it is not new synthesis that is being turned-on, but instead phospholipid is transferred from outside the PMS into the PMS. Although there are many possible mechanisms that can be imagined to account for the transfer of phospholipid within or between membranes, we have no evidence to favor one over the other.

There is an additional and significant implication of these data. Because we know that new protein, and BChl are inserted into pre-existing PMS, that the amount of PMS is constant for a particular steady state (determined by the incident light intensity), and that the transfer of phospholipid to the PMS at the time of cell division is into these pre-existing invaginations, we can only conclude that the invaginations *themselves* are replicated as a means of conserving the specific cellular PMS content. This is in opposition to the formation of new invaginations as a means of maintaining the specific cellular PMS content. It may be suggested that the formation of PMS invaginations is a specialized case of septum formation, which also takes place at a particular time in the cell cycle.

We have other data, which, in light of the preceding discussion, can finally be interpreted. Following a shift-down in light intensity (600–30 fc) pre-existing PMS continues to replicate as if no alteration in light intensity has taken place, except for the derepressed accumulation of LH(II) complexes. In addition, entirely new invaginations are formed. These experiments were performed using asynchronous cell populations, but through the use of synchronous cell cultures, we should be able to precisely define these changes.

Finally, there is one additional observation of major significance. The ability to demonstrate the existence of proteins that are quantitatively unique to either the PMS (BChl–protein complexes) or to the CM (penicillin-binding proteins; Shepherd *et al.*, 1981) within the same cell implies that the information necessary for insertion of a protein into a particular membrane system resides not only with the protein in question, but also with the membrane system. This observation is important when considering the biosynthesis of cell membranes in general. Just as specific receptor molecules exist on the outer surface of cells, they must also exist on the inner surface of cellular membranes.

III. Chloroplasts

A. Enzymatic Properties and Polypeptide Composition of Thylakoid Functional Complexes

Chloroplast thylakoids consist of pigments and enzymes capable of light trapping and energy conversion via two photochemical reactions, using associated electron-transport processes and energy-coupling reactions involved in ATP synthesis. (For a general background, see Govindjee and Govindjee, 1975.) Noncyclic electron flow is mediated by the two reactions acting in series. It is now becoming increasingly evident that the primary photochemistry of PSII shares many properties with the RCs of the purple sulfur bacteria, whereas PSI has properties similar to the RCs of the green bacteria (see Wraight, Chapter 2, this volume, and for further details, Okamura *et al.*, Chapter 5, this volume). The electron transport carriers, which interconnect the two photosystems, include a complex of enzymes with striking similarity to the Cyt *b-c*₁ complex of mitochondria and to the Cyt complex of photosynthetic bacteria. The ATPase of chloroplast thylakoids has numerous similar properties to the corresponding energy-coupling enzyme complex of mitochondria and bacteria. The uniqueness of green-plant photosynthetic membranes is therefore not in the special character of their components, but in the ways in which these components have been modified and structurally organized to create the successful coordination of a multistep, two RC energy-conversion process with high quantum efficiency. For an earlier picture, see Arntzen and Briantais (1975).

1. PHOTOSYSTEM II

A working definition of PSII is 'an assemblage of proteins which binds Chls (and other pigments), which is capable of light-induced reduction of plastoquinone, and which can generate a strong oxidant that recovers electrons from water.' The electron transport components are known to include a RC Chl *a* P680, two or more electron donors that act on the oxidizing side of the center, an intermediate electron acceptor (A_{II,1},* probably a pheophytin) and two bound quinones (Q and B) which act as primary and secondary stable electron acceptors. (See Parson and Ke, Chapter 8, and Cramer and Crofts, Chapter 9, this volume.)

Highly purified PSII preparations have now become available for

*An electron acceptor (A) of PSII that is the first one (1) in the sequence. There is already an indication (see Wraight, Chapter 2, this volume) that pheophytin may be preceded by another intermediate labeled as "C."

correlative polypeptide-function analysis. The polypeptide complement of a PSII preparation obtained from pea (*Pisum sativum*) chloroplasts is shown in Fig. 4. The isolation procedure for this preparation, which attempted to retain "native" PSII properties (including RC activity plus associated secondary electron donors-acceptors as well as antennae pigment-proteins), contains more than 10 polypeptides. Several of these have been assigned functional roles.

Polypeptide species of 40–50 kD are now generally accepted to be components of the RC (see von Wettstein *et al.*, 1980). These are absent in a *Chlamydomonas* mutant blocked in PSII photochemistry (Chua and Bennoun, 1975). A barley mutant lacking PSII activity is deficient in a 46 kD polypeptide (Simpson *et al.*, 1978). Polypeptides of 45–50 kD have been shown to bind Chl when separated upon nondenaturing SDS polyacrylamide gels (Delepelaire and Chua, 1979). The bound pigments presumably include a portion or all of the 40–50 Chl *a*, which is associated with the PSII "core" complex (Satoh, 1979; Diner and Wollman, 1980), as well as the RC P680 Chl. Vigorous detergent treatments coupled with specific purification procedures have been utilized to obtain preparations with only 2–3 major polypeptides primarily in the 40–50 kD size class (Satoh, 1979; Diner and Wollman, 1980). These retain PSII functional activity.

The biochemical nature of electron transport carriers acting on the donor side of PSII is not known (also see Wydrzynski, Chapter 10, this volume). Evidence with mutants of *Chlamydomonas* (Diner and Wollman, 1980) indicated that polypeptides in the 18- and 21-kD size classes are required for PSII donor side components. In submembrane particles prepared from *Chlamydomonas* mutant chloroplasts, Diner and Bowes (1981) gathered spectral evidence for two electron donors ($D_{II,1}$, $D_{II,2}$) to the PSII RC Chl *a*. Only the tertiary donor $D_{II,3}$ was removed from the particles as polypeptides including the 18- and 21-kD size classes were depleted by fractionating the particles on a DEAE-Sephadex column. The secondary electron donor $D_{II,2}$ may, therefore, be associated with the 40–50 kD reaction center polypeptides.

The primary and secondary stable electron acceptors for PSII are quinones bound to proteins (see Wraight, Chapter 2; Parson and Ke, Chapter 8; Cramer and Crofts, Chapter 9, this volume). (For a review on the acceptor side of PSII, see Vermaas and Govindjee, 1981.) It seems likely that the primary quinone acceptor Q is associated with the 40–50-kD RC polypeptides, although this has not been rigorously demonstrated. A polypeptide of 32 kD is absent in PSII-blocked mutants of maize (Leto and Miles, 1980). This 32-kD polypeptide was suggested to

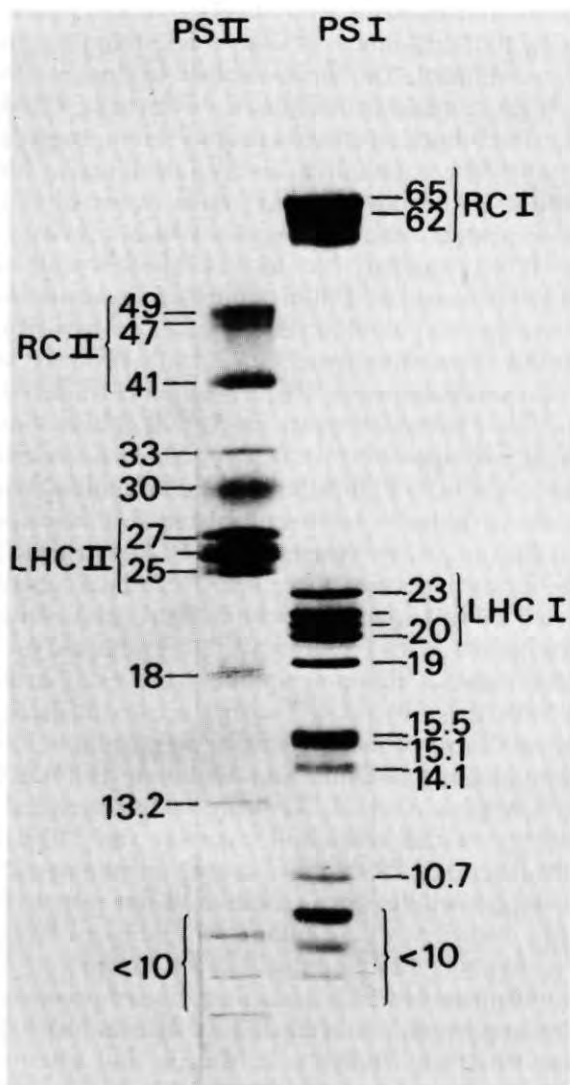

FIG. 4. The polypeptide profiles of isolated PSII and PSI complexes. The PSI preparation was as described by Mullet *et al.* (1980a) for the "PSI-110" complex. The PSII preparation was as described by Mullet and Arntzen (1980). In both cases, the samples were derived from pea (*Pisum sativum* L.) chloroplasts. The SDS-polyacrylamide slab gel was prepared using 8 M urea as also described by Mullet and Arntzen (1980). The numbers indicate the molecular size of peptides in kilodaltons (kD); RC stands for reaction center complex, and LHC for light-harvesting complex.

be the apoprotein of the secondary PSII electron acceptor B (\equiv R) (Pfister and Arntzen, 1979). Removal of this protein from intact membranes by trypsin treatment blocks the function of B but does not interfere with electron flow from water to Q (Steinback *et al.*, 1981). The high affinity binding site for PSII-directed triazine herbicides has been demonstrated to be in the 32–34-kD polypeptides (Mullet and Arntzen, 1980; Pfister *et al.*, 1981).^{*} These herbicides alter the redox potential of the quinone cofactor of B coincident with binding. Data of Matoo *et al.* (1981) and Steinback *et al.* (1981) indicate that the 32 kD polypeptide determinants of B function are identical to a chloroplast encoded “photogene” product, which is synthesized as a larger size-class precursor and which is “processed” in the membrane from 34 to 32 kD (reviewed by Steinback, 1980). This polypeptide species undergoes more rapid synthesis and turnover than other thylakoid proteins (Edelman and Reinfeld, 1980); the functional significance of this turnover remains unclear.

Cytochrome *b-559* is a tightly bound constituent of PSII submembrane preparations. This Cyt has been isolated and was found to have a value of 45 kD for the protein (Garewal and Wasserman, 1974) or 37 kD for the polypeptide (Lach and Böger, 1977). Zielinski and Price (1980) indicated that a 6 kD subunit of Cyt *b-559* is detected on dissociating SDS polyacrylamide gels.

In summary, most of the polypeptides recovered in isolated PSII preparations have been correlated with electron transport functions. The relatively small size of the particulate preparations, as well as their apparent homogeneity (see Diner and Wollman, 1980) indicate a uniform structural organization of the “core” photochemical complex of PSII. The identity of the exoplasmic fracture face (EF) particle visualized in freeze-fractured membranes as the morphological counterpart of this core complex will be detailed later.

2. PHOTOSYSTEM I

A working definition of PSI is ‘an assemblage of proteins which binds Chls (and other pigments) and is capable of light-induced generation of a weak oxidant that can oxidize plastocyanin and a strong reductant which can transfer electrons to ferredoxin.’ The electron transfer components involved in these reactions are known to include P700 (the RC Chl), an intermediate electron acceptor A_{L1} (probably a Chl), and three stable electron acceptors (Designated as X, FeS–B, FeS–A), which are iron–sulfur proteins of low redox potential (to E_m (pH 10) = -0.73 V;

^{*}The binding of CO₂, which regulates electron flow in PSII, is also in the B region (Vermaas and Govindjee, Chapter 16, Vol. II, 1982).

Ke *et al.*, 1977). The functional properties of these components are reviewed by Parson and Ke, Chapter 8, and Cramer and Crofts, Chapter 9, in this volume, and by Sauer (1979).

Photosystem I preparations of relatively high purity have been obtained by detergent fractionation since 1964 (Boardman and Anderson, 1964; Vernon *et al.*, 1966; Wessels and Voorn, 1972; see Arntzen and Briantais, 1975). In these early preparations, the PSI units maintained a relatively large complement of LH Chl antennae; Chl/P700 ratios ranged from 80 to 150 (Boardman and Anderson, 1964; Wessels and Voorn, 1972). Numerous attempts have been made to isolate "RC" preparations of PSI that are extensively depleted in antennae Chls; in such preparations, Chl/P700 ratios have ranged from 7:1 (Ikegami, 1976), 15:1 (Vacek *et al.*, 1977), to 40:1 (Bengis and Nelson, 1977).

An example of the polypeptide composition of a PSI preparation, which retained the LH antennae Chl, is shown in Fig. 4. This preparation, which contained 110 Chls/P700, exhibited at least 13 polypeptides (Mullet *et al.*, 1980a). Functional roles for several of these components can now be put forward.

The RC polypeptides of PSI can be isolated through the use of sodium dodecyl sulfate (SDS), lithium dodecyl sulfate (LDS), or Triton X-100. These preparations, sometimes called the P700 chlorophyll *a*-protein, were reported to have a value of 110 kD in a partially denatured form (Thornber, 1975). The samples prepared in SDS bind approximately 40 Chl/P700. When run on denaturing polyacrylamide gels, these PSI RC preparations are characterized by polypeptides of 65–70 kD (Bengis and Nelson, 1977; Hauska *et al.*, 1981; Rutherford and Mullet, 1981) (size differences are due to varying gel procedures between laboratories and/or plant species differences). It is not yet resolved as to whether the RC preparations contain one or two different polypeptides species or minor structural variants of a single polypeptide. Photosystem I RC preparations containing only one polypeptide species of 70 kD demonstrated a light-induced absorbance change due to the oxidation of P700 (Bengis and Nelsen, 1975). A similar preparation, which contained a polypeptide of ~ 68 kD, demonstrated a light-induced spin-polarized triplet signal observed by ESR. This signal was attributed to the triplet state of P700 formed by recombination of the light-induced radical pair $P700^+ \cdot A_{1,1}^+$ (Rutherford and Mullet, 1981).

In related studies, Chua and Bennoun (1975) demonstrated that a *Chlamydomonas* mutant deficient in PSI activity lacked a polypeptide of 66 kD. A nuclear gene mutant of barley designated *viridis-n³⁴* has normal PSII activity but lacks PSI as judged by the absence of chemically induced P700 spectral changes. This mutant was found to be deficient in

the 110-kD P700 chlorophyll *a*-protein (Møller *et al.*, 1980; von Wettstein *et al.*, 1982). Both genetic studies support the concept of a 110 kD (65–70-kD apoprotein) PSI RC protein.

When isolated from chloroplast membranes via detergent techniques, PSI exists as an aggregate complex containing 13 or more polypeptides (see Fig. 4). Analysis of mutants of both algae and higher plants have supported the concept that PSI requires the concerted interaction of multiple polypeptides for both functional expression as well as physiological stability within the membrane. Girard *et al.* (1980) conducted a genetic analysis of 25 nuclear mutants, which were deficient in the 110 kD P700 Chl *a* polypeptide. These mutants belonged to 13 complementation groups scattered throughout the nuclear genome. In all cases, in addition to the lack of the 110 kD polypeptide, each mutant also was deficient in a specific set of 6 low molecular weight thylakoid polypeptides of apparent values near 20, 19, 14, 10, 4, and 3 kD. All of these polypeptides were recovered in a detergent-derived PSI preparation similar to that shown in Fig. 4. Girard *et al.* (1981) concluded that a reason for the pleiotropic deficiency of a specific set of thylakoid polypeptides in all mutants lacking PSI activity could be that all polypeptides in question were part of the multisubunit complex required for PSI. By this concept, the absence of one or more constituent polypeptides would block either the synthesis or assembly of the other components of the same complex. A very similar conclusion was reached by Hiller *et al.* (1980) in the characterization of barley mutant chloroplasts that lack PSI activity. In their studies, several nonallelic mutants lacked or were deficient in the "P700 Chl *a*-protein" as well as several lower molecular values (18.3, 15.2, and 13.5 kD) of polypeptides. (We should note that there are significant differences in molecular weight species of polypeptides in thylakoids of different plant species; it is therefore impossible to make direct correlations between the exact polypeptide size classes between most species).

A PSI preparation, which has been extensively utilized for characterization of individual polypeptide function, was described by Bengis and Nelson (1975). SDS-Polyacrylamide disk gels of this preparation were able to resolve six polypeptides, including a PSI RC polypeptide of 70 kD and five subunits of values in the range of 5–20 kD. These were designated as subunits 2–6. Various extraction procedures and/or immunochemistry techniques were used to identify the function of the various components. Subunit 3 has been implicated as functioning on the electron donor side of the RC (Bengis and Nelson, 1977; Nelson and Natsani, 1977). Haehnel *et al.* (1980) supported this idea by demonstrating that subunit 3 was involved in binding of plastocyanin to the RC complex. It was discovered that mild treatment of the PSI preparations

with an anionic detergent lead to the release of subunits 4, 5, and 6 with a parallel loss of ESR signals from iron-sulfur proteins known to act as stable PSI electron acceptors. A similar technique for depletion of PSI particles by detergents was adopted by Rutherford and Mullet (1981); the detergent-derived photosystem RC complexes were depleted in polypeptides of approximately 19, 14, 15, and 10-kD, which was parallel with the loss of ESR-detected iron-sulfur centers. In the studies of Rutherford and Mullet, a light-induced spin-polarized triplet signal could be observed by ESR in the PSI RC preparation, which was depleted of iron-sulfur polypeptides. This indicates that the primary electron acceptor, $A_{1,1}$, must be a component of the 65–70 kD polypeptide, which serves as an apoprotein for P700.

The involvement of polypeptides acting as iron-sulfur centers on the electron acceptor side of PSI have been investigated in barley chloroplasts that were allowed to develop in the presence of radiolabeled ^{59}Fe . Under these conditions, two polypeptides (16 and 17 kD) were found to incorporate radioactivity (von Wettstein *et al.*, 1980). In total, the data available clearly indicate that at least two polypeptides of ~15–17 kD are involved as iron-sulfur center apoproteins and that a third polypeptide in this general molecular-weight size is further involved in electron transport activities on the acceptor side of PSI.

It should be noted from the studies of Rutherford and Mullet (1981) and Nelson and collaborators (Bengis and Nelson, 1977; Nelson and Natsani, 1977) that subunit 2, a polypeptide near 22 kD, was tightly associated with the P700 Chl *a*-apoprotein. Nelson and Natsani (1977) deduced that subunit 2 was a nearest neighbor of the 70 kD P700 apoprotein. The specific function of this polypeptide has not been determined. Studies of PSI preparations, using high resolution polyacrylamide slab-gel techniques, have now resolved several additional polypeptides in the low molecular weight range that were not detected in the earlier studies by Nelson and collaborators. The possible functional importance of these components has not been evaluated.

The functional activity of the P700 Chl *a*-protein, with its associated antennae Chls, can be maintained even in the isolated protein subunit. Hauska (1980) incorporated the P700 RC protein (subunit I as defined by Bengis and Nelson, 1975) into liposomes and observed a light-induced quenching of 9-aminoacridine. This quenching was uncoupler sensitive, which reflected an acidification inside the lipid vesicles. It can therefore be concluded that subunit 1 will span the lipid bilayer and can mediate light-induced charge separation across it.

A further discussion of the comparison of the Bengis and Nelson (1975) preparation with more recent PSI preparations has been provided by Hauska *et al.* (1981).

3. CYTOCHROME b_6-f COMPLEX

A series of electron transport carriers are known to interconnect the reactions of PSII and PSI. Of these, plastoquinone (PQ) is known to accept electrons from the bound quinones acting on the acceptor side of PSII. The lipid-soluble PQ acts as a shuttle to transfer electrons and protons laterally along the lipid bilayer. It is now well accepted that fluorescence chl *a* transients allow the estimation of the electron acceptor pool size (primarily oxidized PQ) as a function of the number of PSII centers active in photochemistry (see Zankel and Kok, 1972). The quinone mobility in chloroplast membranes will be discussed in detail by Cramer and Crofts, Chapter 9, this volume.

The physiological electron acceptor for PQH_2 is a complex of enzymes sometimes referred to as the Cyt b_6-f complex. This nonpigmented protein complex was first isolated and characterized from chloroplasts by Nelson and Neumann (1972). In most respects, the complex appears very similar to the mitochondrial respiratory chain component designated complex III (the UQ:Cyt *c* reductase; von Jagow and Sebald, 1980). Complex III of mitochondria appears to form a discrete structural and functional subunit of the mitochondrial inner membrane (Hatefi and Stiggal, 1976).

The isolated protein complex obtained by Nelson and Neumann (1972), was found to contain Cyt b_6-f non-heme iron, and phospholipids. Ke *et al.* (1975) described the isolation of a similar complex using the detergent Triton X-100; this complex reportedly contained a Cu-containing protein, which was similar to plastocyanin. Hauska *et al.* (1981) and Hurt and Hauska (1981) reported a new procedure to obtain a highly resolved Cyt complex. Their preparation was found to contain five polypeptide components with molecular values of 34, 33, 23, 20, and 17.5 kD. The complex contained two Cyts b_6 and 2 non-heme irons per Cyt *f*. ESR spectra clearly showed a Rieske iron-sulfur center ($g = 1.89$). The isolated complex demonstrated plastoquinol-plastocyanin oxidoreductase activity, which was inhibited by the quinone analogue dibromothymoquinone (DBMIB), and UHDBT (a hydroxy quinoline-quinone). (Also see chapter by Cramer and Crofts, Chapter 9, this volume.) Hauska *et al.* (1981) demonstrated that Cyt b_6-f complex can be reconstituted into liposomes together with an isolated PSI complex. This artificial membrane system was capable of mediating the photooxidation of Cyt *f*; this reaction was totally dependent upon the addition of plastocyanin to the preparation. The membrane system could also catalyze the photoreduction of Cyt b_6 by PSI RC.

A procedure for the direct identification of heme proteins in thylakoid polypeptide patterns of polyacrylamide gels has been developed

by Høyer-Hanson (1980). The technique is based upon the preferential staining of gels with 3,3',5,5'-tetramethylbenzidine- H_2O_2 . Cytochrome *f* was identified as having a mass of 33 kD and a subunit of Cyt *b*₆ as having a molecular value of 20 kD; these molecular values compare closely with the components of the preparation obtained by Hauska *et al.* (1981). The molecular weight of the Rieske iron-sulfur protein has not been established. In addition, the two other polypeptides, which are contained in the Cyt *b*₆-*f* complex of Hauska *et al.* (1981), have not been identified, although it is tempting to speculate that one of these may be a Q-binding protein analogous to the UQ-binding protein of complex 3 in mitochondria (Yu and Yu, 1980).

4. THE ATPase

Chloroplast thylakoid membranes contain a protein capable of utilizing energy derived from electron transport to form ATP from ADP and inorganic phosphate. The protein complex, which is highly analogous to that from mitochondrial inner membranes and bacterial membranes, has been variously referred to as an ATPase complex, a proton-translocating ATPase, a *N,N'*-dicyclohexylcarbodiimide (DCCD) sensitive ATPase, or a coupling factor (Shavit, 1980). (See McCarty and Carmeli, Chapter 14, this volume, for details.) The membrane-bound complex can be assayed by following ATP hydrolysis or other ATP dependent functions, as well as ATP synthesis. The complex is localized both within and upon the surface of the chloroplast membranes. The extrinsic (surface-exposed) portion of the ATPase complex is termed CF₁. This binds to a hydrophobic component designated as CF₀, which serves as a proton channel and is the site of binding of DCCD, an inhibitor of ATP synthesis and proton transport.

CF₁ contains five subunits and has an aggregate value of approximately 325 kD (Shavit, 1980). The mass of the individual subunits varies with plant species. For example, the CF₁ from pea thylakoids contains five polypeptides (α , β , γ , δ , ϵ = 58, 55, 37, 18, and 13.5 kD, respectively; Mullet *et al.*, 1981c). The isolated CF₁ from chloroplast thylakoids can be clearly distinguished by electron microscopy as a subunit of approximately a 110 Å in diameter (Moudrianakis, 1968; Carmeli and Racker, 1973; Miller and Staehelin, 1976; Mullet *et al.*, 1981c).

The hydrophobic portion of the ATPase complex was first isolated by Younis and Winget (1977). Pick and Racker (1979) reported the isolation of an ATPase complex that contained both the five-subunit CF₁ as well as the hydrophobic CF₀ portion. The entire complex contained the five polypeptides associated with CF₁ as well as four additional polypeptides (17.5, 15.5, 13.5, and 7.5 kD). The 7.5-kD polypeptide is known to

be the DCCD-binding proteolipid (Nelson *et al.*, 1977), which functions as a proton channel.

The isolated ATPase complex, prepared by the procedure of Pick and Racker (1979), has been reconstituted together with a PSI complex into phospholipid vesicles by Hauska *et al.* (1980). In this reconstituted system, light-induced ATP synthesis was observed that was sensitive to uncouplers and DCCD. A structural analysis of the reconstituted ATPase complexes in phospholipid vesicles has revealed the surface exposed CF_1 , as well as an intrinsic membrane protein complex, which was interpreted to be the structural unit of the CF_0 (Mullet *et al.*, 1981c). The structural interpretation of the hydrophobic portion of the ATPase implies that several DCCD-binding proteolipids are structurally associated in the CF_0 together with the three additional polypeptides; these exist as particles that average 96 Å in diameter when examined by the freeze fracture technique.

5. SUMMARY

Four classes of enzymatically active protein complexes can be solubilized from chloroplast membranes. Each contains five or more polypeptides. In total, these complexes represent the entire energy-coupling reactions of photosynthesis: PSII generates a strong oxidant to remove electrons from water and catalyzes the reduction of PQ; the Cyt b_6-f complex oxidizes PQH₂ and reduces plastocyanin; PSI generates an oxidant that removes electrons from plastocyanin and concomitantly generates a strong reductant that provides electrons to ferredoxin; an ATPase utilizes a proton motive force to catalyze ATP synthesis. The highly defined functional properties and polypeptide composition of each of these complexes implies a precise structural organization of each of the protein complexes. Our interpretation of their gross pattern of organization within the chloroplast membrane, and the resultant pattern of electron flow in the membrane is indicated in Fig. 5. This model does not attempt to interpret the organization of individual polypeptides within each of the functional complexes of the membrane. Several reviews have assessed the vectorial organization of the electron carriers within these complexes (Trebst, 1974, 1980; Arntzen, 1978); unfortunately, an understanding of how individual proteins interact or are oriented within any of these complexes remains almost totally unknown. The reader is encouraged to read various chapters that deal with the details of the reactions summarized earlier. For example, see in this volume, Parson and Ke (Chapter 8) and Cramer and Crofts (Chapter 9) for electron flow; Wydrzynski (Chapter 10) for O₂ evolution; Ort and Melandri (Chapter 12), Junge and Jackson (Chapter 13), and McCarty and Carmeli (Chapter 14) for steps leading to ATP synthesis.

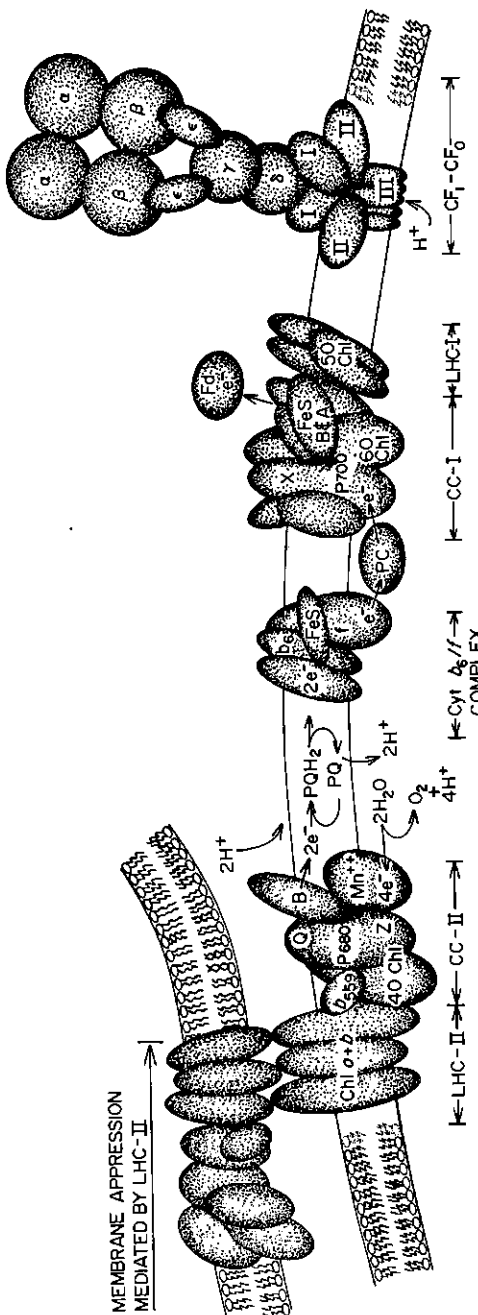

FIG. 5. A stylized model of the four structural units of function, which catalyze the light-harvesting, electron transport, and energy-coupling reactions of photosynthesis. PSII consists of two parts: a LH pigment-protein complex [LHC(II)] and a core complex (CCII), which catalyzes electron transfer from water to plastoquinone (PQ). A Cyt *b₆-f* complex [also containing a Rieske iron-sulfur (Fe-S) center] oxidizes the plastoquinone (PQH₂) and donates electrons to plastocyanin (PC), PSI, consisting of a LH pigment-protein complex [LHC(I)] and a core complex (CCI) oxidizes plastocyanin and transfers electron to NADP⁺ (via ferredoxin). The ATPase, which uses a proton gradient to drive ATP synthesis, consists of a hydrophobic CF₀ and a surface-bound CF₁.

B. Thylakoid Pigment-Proteins

The radiant energy that drives the light reactions of photosynthesis is largely absorbed by antenna chlorophylls, which transfer energy to the reaction center pigments of PSI and PSII. The concepts of how these antenna pigments are organized have evolved rapidly in recent years. Within the last 10 years, the view that Chl is arranged in extended sheet-like aggregates associated with the lipid bilayer has given way to the concept that all Chl is noncovalently associated with protein (see Thornber, 1975; Matthews and Fenna, 1980). Over a slightly longer time frame, the picture of a "photosynthetic unit" has also undergone a change. In 1932, Emerson and Arnold found that a minimum of 2500 Chls participate in photochemistry leading to the production of one molecule of O₂ (see Govindjee and Govindjee, 1975, for a discussion). This implied that 600 Chls act in concert as a "photosynthetic unit" for transfer of one electron through the chain (see Park, 1965). In 1964, Park and Biggins introduced the idea that there could be a structural counterpart for the functional unit; a "quantaosome" was hypothesized to be a membrane subunit housing the pigments and enzymes participating in the transfer of one electron through one chain. The concept of a photosynthetic unit has evolved into (or reverted to) a general definition according to which a photosynthetic RC and its associated antenna Chls form one unit (i.e., separate photosynthetic units or a "separate package model" for PSI and PSII; see discussion in Arntzen *et al.*, 1977). The following information will deal with the organization of LH Chl proteins within each of the units of PSI and PSII. We should emphasize, however, that the functional evaluation of a photosynthetic unit in intact membranes is largely a measure of statistical entities, not structural components (see e.g., Arntzen *et al.*, 1977).

Our understanding of pigment proteins has largely been dependent upon the techniques used to isolate these entities. Unfortunately, our ability to compare the findings of many laboratories has been hampered by the fact that there is no uniform nomenclature to describe the data obtained via the numerous methodologies. A simplistic terminology, based in part upon that used for photosynthetic bacteria (Loach, 1980), will be used in the following discussion. The conceptual basis for the terminology is shown in Fig. 6 (from Mullet *et al.*, 1981b). The model recognizes that both photosystems exist as structural entities within the chloroplast membrane. These structural entities can be released as monomeric units from the lipid bilayer with mild, neutral detergents such as digitonin or Triton X-100. As will be discussed later, both photosystems appear to have a pigmented "core complex" (polypeptides containing 40–60 Chls plus the RC and electron donors and acceptors).

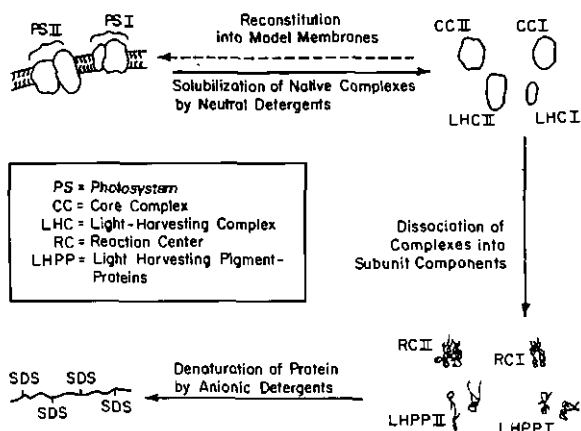

FIG. 6. A summary of the procedures utilized to dissociate photosystems in chloroplast membranes into protein complexes, then into pigment-proteins and RCs, and finally into individual polypeptides. The nomenclature used to describe each step is indicated in the inset.

This “core” can be considered as the minimal functional unit of a photosystem in a physiological context. The term *photosystem* (PS) is used to identify the entire structural unit of PSI or PSII—both the core complex and a specific quantity of antenna pigment-proteins. The latter are organized in LH complexes, with one or more complex per PS. Through the use of charged detergents such as LDS or SDS, either core or LH complexes may be subdivided to release the pigmented RC polypeptides or LH Chl proteins. Each of these may, in turn, be totally dissociated under denaturing conditions to yield individual apoproteins that may be characterized by techniques such as polyacrylamide gel electrophoresis.

1. LIGHT-HARVESTING COMPLEX (II)

Polypeptides, which bind both Chl *a* and *b* and which largely serve as antenna for PSII, have received nearly continuous attention for 15 years. Their discovery relates only to that portion of Fig. 6 that relates to the dissociation of membranes into pigment proteins.

In the earliest report on separation of pigment proteins, Ogawa *et al.* (1966) resolved a SDS-solubilized, pigmented species on polyacrylamide gels as a green band of approximately 30 kD (apparent molecular mass). This observation has been repeated in many laboratories; the complex is now usually designated as Chl-protein complex II (CPII) or the “light-harvesting chlorophyll *a*-*b* protein” (Thornber, 1975). In recent years, a large number of innovations have been introduced for the methodology of separating pigment-proteins upon gels (summarized by Machold *et*

al., 1979); with respect to CPII, it has been routinely observed that Chl *a-b* proteins of lower electrophoretic mobility are derived under milder solubilization conditions. The Chl *a-b*-containing polypeptides, observed with these conditions at apparent molecular values of approximately 50, 71, and 107 kD, are thought to be multimers of the individual CPII proteins (see Machold *et al.*, 1979).

The multimers of CPII polypeptides observed on gels may be equivalent to subunits of the aggregate forms of the pigment-proteins that exist in the intact membrane. Washing thylakoids in "low-salt" medium was found to predispose thylakoids to easy solubilization by low levels of uncharged detergents such as digitonin or Triton X-100 (Arntzen and Ditto, 1976; Burke *et al.*, 1978); this resulted in the release of pigment-protein complexes, which could be purified upon sucrose gradients. This technique was used to isolate an LH complex, which is functionally associated with PSII; this is designated LHC(II). Upon exposure to anionic detergents, LHC(II) may be dissociated into constituent LH Chl *a-b* pigment-proteins.

LHC(II) has no enzymatic or photochemical activity. When incorporated into phospholipid vesicles it can be observed as an 80 Å membrane subunit (Steinback *et al.*, 1978; McDonnell and Staehelin, 1980; Mullet and Arntzen, 1980; Rytic and Anderson, 1980). The purified complex contains a major polypeptide of 27 kD and three polypeptides of 29, 26, and 25 kD (Mullet *et al.*, 1981a). It was estimated that one LHC(II) structural unit would consist of 4-6 individual polypeptides, each of which binds 10-13 Chls *a + b* in the native complex (Burke *et al.*, 1978; Mullet *et al.*, 1981a).

It is likely that the various polypeptides of the LHC(II) are structurally related. The two major CPII polypeptides of *Chlamydomonas* are immunologically cross-reactive (Chua and Blomberg, 1979). One major LHC(II) polypeptide is absent in a Chl *b*-less barley mutant (Boardman *et al.*, 1978; Burke *et al.*, 1979); this is evidence for separate developmental controls for integration and/or turnover for individual LHC(II) polypeptides. At present, the mechanisms influencing protein-protein interaction within one LHC(II) complex are unknown.

2. LIGHT-HARVESTING COMPLEX (I)

Whereas the existence of LHC(II) (or CPII) has been known for many years, the existence of an analogous antenna-protein assemblage associated with PSI has only been a hypothesis. Mullet *et al.* (1980a,b) prepared a "native" PSI particle, which contained 110 Chls per P700. Triton X-100 extraction of this preparation caused the removal of nearly one-half of these antenna pigments together with four polypep-

tides of 21–24 kD. These polypeptides were suggested to bind Chl and act as a LH complex serving as the peripheral antenna of PSI [LHC(I)].

Two additional lines of evidence support the existence of a LHC(I). First, studies of developing and mutant membranes demonstrate a correlation between the absence of the 21–24 kD polypeptides and Chl *a* fluorescence properties of the thylakoids associated with PSI antenna (Mullet *et al.*, 1980b). A barley mutant, *viridis-zb⁶³*, presents the opposite example; the LHC(I) polypeptides are present and long wavelength Chl *a* fluorescence associated with the PSI antenna is present, whereas the PSI core complex polypeptides and especially the 66–68 kD CPI proteins are absent (Hiller *et al.*, 1980; Mullet *et al.*, 1981b). A second line of evidence for the existence of the LHC(I) is the fact that the complex can be isolated and purified (Haworth *et al.*, 1981; Mullet *et al.*, 1981b). The isolated complex binds both Chls *a* and *b*, with an *a*–*b* ratio near 4 (Haworth *et al.*, 1981). It retains long wavelength Chl fluorescence (peak emission at 735 nm at 77°K). This pigment–protein is highly unstable in anionic detergents.

In summary, both photosystems are comprised of a “core complex,” which binds approximately 40–60 Chls per RC. In addition, each photosystem contains LH pigment–proteins organized as a complex. Both LHC(I) and LHC(II) have been isolated and the pigment–proteins of LHC(II) have been extensively characterized. Unlike photosynthetic bacteria, RC Chl complexes P700 and P680 have not yet been isolated.

C. Structural Morphology of Thylakoid Membranes

1. REVERSIBLE MEMBRANE APPRESSION (GRANA STACKING)

Intact chloroplasts can be readily isolated from many green eukaryotic organisms. These intact plastids will carry out light-driven CO₂ fixation. When the intact organelles are osmotically shocked, the soluble enzymes, which catalyze the dark reactions (CO₂ fixation), are released, and the remaining internal membranes (thylakoids) can be easily isolated and purified.

Isolated chloroplast lamellae, when maintained in the presence of ≥ 3 mM divalent cations or ≥ 150 mM monovalent cations retain their in situ structural differentiation; single membranes (stromal lamellae) interconnect grana stacks. The latter are a series of 2–25 tightly appressed membrane vesicles resembling a stack of coins. If the isolated thylakoids are washed in low-salt medium (10–30 mM monovalent cations), grana stacks are lost, and a system of connected, unappressed thylakoid vesicles form. Upon readdition of cations, the unstacking process is reversed

to give rise to new regions of membrane contact, which often resemble the original grana stacks. The components of the chloroplast membrane, which are responsible for the reversible membrane-membrane interactions, as well as the involvement of cations in regulating these interactions, will be discussed in the next sections.

2. SUPRAMOLECULAR THYLAKOID STRUCTURE

The organization of enzyme complexes within and upon the thylakoid membranes can be examined by electron microscopy. The techniques of deep-etching and negative staining allow visualization of surface-exposed portions of the thylakoid membrane (see reviews by Staehelin *et al.*, 1977 and Arntzen, 1978). Particles that extend out from the membrane surface are largely restricted to unstacked, stroma lamellae (Miller and Staehelin, 1976) and are in size classes of ~ 100 – 120 Å in diameter. Based on differential removal after washing thylakoid preparations in solutions of varying ionic strength and/or EDTA, it has been demonstrated that these surface-exposed membrane particles represent ribulose bisphosphate (RUBP) carboxylase and CF_1 (the extrinsic membrane component of the chloroplast ATPase). When chloroplasts are unstacked by transfer of thylakoid lamellae to low-salt solutions, the surface-exposed subunits representing CF_1 become uniformly distributed over the exposed, unappressed membrane surfaces indicating a lateral mobility of the CF_0 (hydrophobic portion of the chloroplast ATPase) throughout the lipid phase of the membrane (Miller and Staehelin, 1976).

Intrinsic protein complexes of chloroplast thylakoids can be visualized by freeze-etching techniques for electron microscopy. An example of such a preparation is shown in Fig. 7. Four types of fracture faces can be visualized in a membrane preparation containing grana stacks. Based upon the knowledge that the freeze-fracture technique causes a membrane to split through the hydrophobic interior of the membrane, the outer-half membrane leaflet of the thylakoids, which is revealed during fracturing, is termed the *protoplasmic face*. It is indicated as either the PF_S (protoplasmic face in stacked regions) or PF_U (protoplasmic face in unstacked stroma lamellae regions). The inner-half membrane leaflet, or exoplasmic face, is similarly indicated as EF_S (*exoplasmic face* of the stacked lamellae region) or EF_U (exoplasmic face in unstacked stroma lamellae; Branton *et al.*, 1975). It can readily be observed from Fig. 7 that in the partition regions (the area of membrane-membrane contact) the PF_S surface is composed of relatively tightly packed but rather indistinct small particles. These average about 80–90 Å in diameter. The opposing half of the partition membrane, the EF_S face, contains rela-

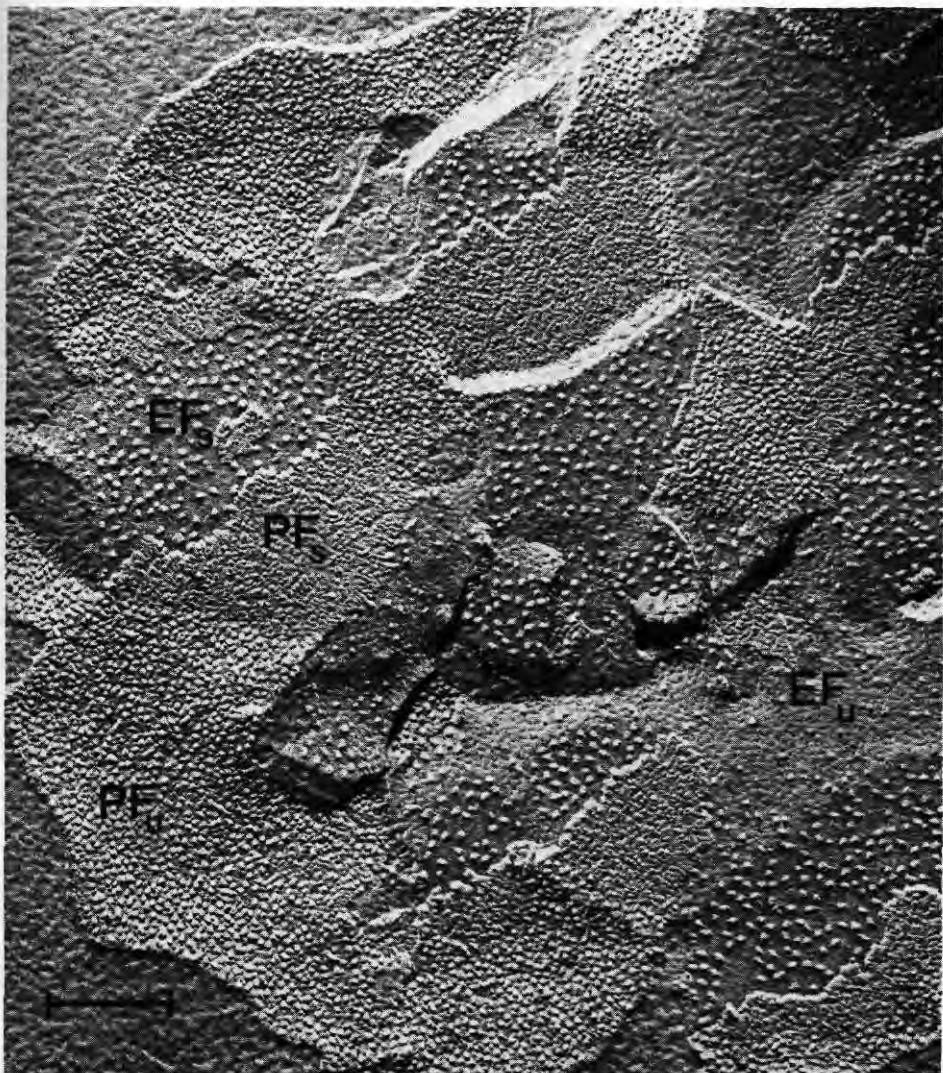

FIG. 7. An isolated chloroplast thylakoid preparation, maintained in a divalent cation solution to preserve grana stacking, as revealed by the freeze-etch procedure. EF_S and EF_U refer to exoplasmic fracture face in stacked and unstacked regions of chloroplast lamellae, respectively; and PF_S and PF_U refer to protoplasmic fracture face in stacked and unstacked regions of chloroplast lamellae, respectively. Bar equals $0.25 \mu\text{m}$. (Micrograph courtesy of L. Andrew Staehelin.)

tively large particles interrupting a smooth lipid bilayer. These particles, which range in size from less than 100 to greater than 180 Å in diameter, are observed at a higher density than the particles on the contiguous membrane surfaces in unstacked regions (the EF_U face). The PF_U face is distinguished from its contiguous PF_S face within the grana stacks by having much more distinct small particles. The particle density of the PF_U and PF_S are approximately equal; those of the PF_U are of two size classes: 80 and 118 Å (Staehelin, 1976; Arntzen, 1978).

When chloroplast thylakoids are unstacked by incubation of the membranes in a solution of low-salt concentration, the particles on the fracture faces become uniformly distributed (Ojakian and Satir, 1974). This is most noticeably evident in an examination of the EF face in Fig. 8. Whereas the large freeze-fracture particles were primarily restricted to the partition region of stacked membranes, these membrane subunits

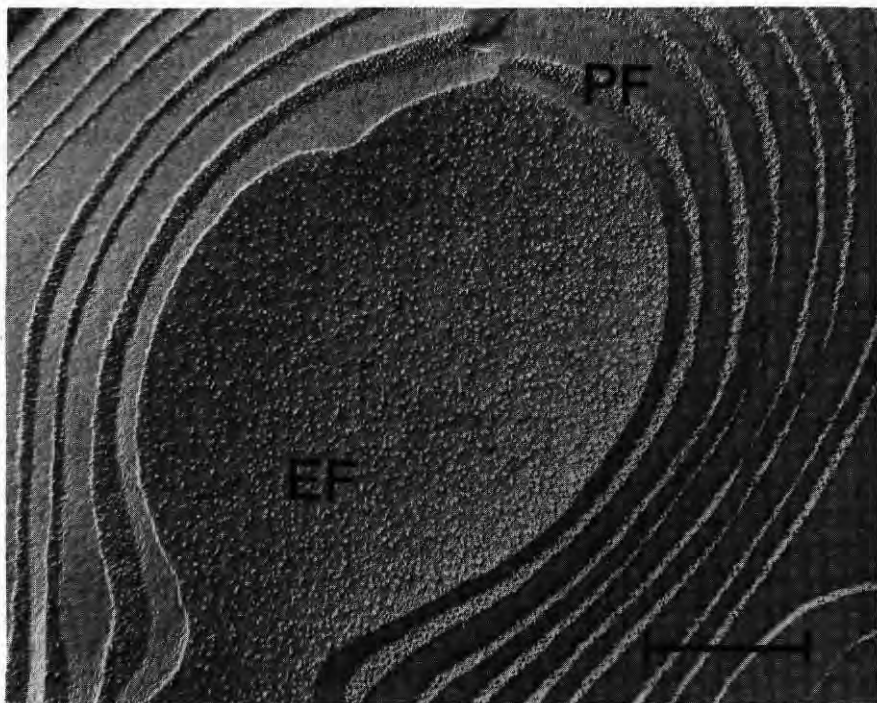

FIG. 8. The freeze-fracture image of isolated thylakoids suspended in a "low-salt" solution, which causes unstacking of grana (note the concentric rings of nonappressed lamellae). The particles of the EF face in this micrograph are rather uniformly distributed as compared to the increased particle density on the EF_S versus the EF_U of Fig. 7. Bar equals 0.5 μm . (Micrograph courtesy of L. Andrew Staehelin.)

become rather uniformly distributed throughout unstacked membranes. As has been previously noted, this excellently demonstrates the mobility of the particles (protein complexes) within the lipid phase of the chloroplast membrane. It has been well documented that addition of either divalent or monovalent cations to unstacked chloroplast membranes results in a reassociation of membrane surfaces to form grana stacks; in concert with this restacking reprocess there is a redistribution of freeze fracture particles giving rise to an increased density of the EF particles within the partition regions (Staehelin, 1976).

D. Distribution and Stoichiometry of Pigment-Protein and Electron Transport Components between Stacked and Unstacked Membranes

The fact that the intrinsic membrane protein complexes, as visualized by freeze-fracture electron microscopy, are unequally distributed in the lateral fashion within the membrane, suggests a difference in the distribution of the main intrinsic macromolecular functional complexes of thylakoid lamellae. It was early demonstrated that fractionation of thylakoids into grana and stroma lamellae fractions by either detergents or mechanical methods gives rise to grana stacks which are enriched in the enzymatic components of PSII, whereas the small vesicles derived from stromal lamellae are correspondingly enriched in PSI (see review in Arntzen, 1978). The stroma lamellae-derived vesicle preparations prepared by either technique have been found to contain approximately 10–15% of the total chloroplast PSII activity. These estimates were based upon partial reactions of electron transport (Armond and Arntzen, 1977) and quantitation of the pigment-protein complex of the preparations (Andersson and Anderson, 1980). The PSII of the stroma lamellae has less associated LH pigment-proteins than PSII within partition regions, based upon analysis of electron transport at various light intensities (Armond and Arntzen, 1977). The distribution of EF particles along the thylakoid membranes corresponds well to the distribution of PSII within these thylakoids (Armond and Arntzen, 1977). It has been hypothesized that the smaller EF_U particles represent PSII centers with a limited amount of associated LH pigment-proteins, whereas the larger EF_S particles represent PSII with a full compliment of LH pigment-proteins (Armond *et al.*, 1977; Staehelin *et al.*, 1977).

The distribution of PSI along thylakoid membranes has also been analyzed in the stroma lamellae preparations as compared to the isolated grana stacks. In most studies, PSI activity has been found in both preparations, although it is relatively enriched in the stroma lamellae when activity is presented on a Chl basis. Andersson and Anderson (1980)

have suggested that there is even more extreme lateral heterogeneity. By analysis of pigment-protein composition using nondissociating SDS-polyacrylamide gel electrophoresis, these authors found a very low level of PSI-associated pigments in highly purified grana partitions. Anderson (1981) has hypothesized that virtually all of PSI is excluded from the grana partitions and is found only in the end regions of a grana thylakoid as well as in the unstacked membranes, whereas PSII and its associated LH complex are highly concentrated in the grana partitions.

It should be emphasized that the stoichiometry and location of functional units along the membrane is not a static property of chloroplasts. Melis and Brown (1980) have carefully demonstrated that the stoichiometric ratio of PSII-PSI centers varies dramatically in chloroplast samples of different developmental state. In chloroplasts with a low LHC(II) content, PSII-PSI ratios over 3 could be observed, whereas values less than unity were found for fully developed chloroplasts. Within mature grana stacks, these authors found ratios of PSII-PSI of approximately 2.

E. Identification of Freeze-Fracture Particles

1. THE EXOPLASMIC FRACTURE FACE PARTICLES

The unequal distribution of both PSII activity and EF particles between stroma lamellae and grana stacks has strongly suggested a correlation that indicates that the EF particles are the morphological counterparts of the PSII enzymatic complex. This hypothesis has been supported by several lines of evidence. The earliest approach to this function-structure correlation has relied on the use of detergents to isolate purified PSII preparations.

Structural analysis of the subfractions from digitonin-treated chloroplast membranes revealed that the PSII preparation was enriched in the large size class of EF particles (Arntzen *et al.*, 1969). Subsequent studies have utilized techniques for initial isolation of grana followed by a subfractionation of the grana-enriched fractions to further separate PSI and PSII. Again, in these preparations, large freeze-fracture particles, which are morphologically identical to the EF_S particles of intact thylakoids, were found in the PSII preparations (Arntzen *et al.*, 1972; Popov *et al.*, 1980). It should be pointed out that these preparations of PSII were enriched in the LH proteins, which bind both Chl *a* and *b*. Like the purification procedure, which caused an enrichment of PSII activity, there was a decrease in the number of small freeze-fracture particles contained in the preparations.

A second major approach to the analysis of the morphological expression of PSII function has been through the use of developing chlo-

roplasts. In developing chloroplasts of *Euglena*, Ophir and Ben-Shaul (1974) found an increase in the size of the particles of the EF face during greening. In a series of studies with developing pea chloroplasts, Armond *et al.* (1977) found that the appearance of the LH Chl *a-b* pigment-protein corresponded with an increase in the size of the EF particles and an onset of grana stacking. These authors hypothesized that an EF particle is a morphological equivalent of a complete PSII complex, which consists of a photochemically active core complex that, in turn, is surrounded by discrete aggregates of the LH complex. Dubertret and Lefort-Tran (1981) conducted similar, independent studies with greening membranes of *Euglena* under intermittent illumination. They also concluded that the PSII core complex is an approximately 80 Å particle of the EF face and that this increases in size as additional LH pigment-proteins for PSII are structurally and functionally added to the complex.

A third approach to the correlation of EF particles with PSII activity has come through studies of various photosynthetic mutants (Simpson *et al.*, 1978; Miller and Cushman, 1979; Olive *et al.*, 1979; Ladygin *et al.*, 1980; Wollman *et al.*, 1980). In general, it can be concluded that in mutants in which there are alterations in the polypeptides associated with the photosystem core complex, there is an alteration either in size or a total absence of particles in the EF fracture face. As an example, in barley mutant *viridis-zd⁶⁹* PSII activity is lacking, although PSI dependent reactions can be measured, and very few freeze-fracture particles are present on the EF_s face, whereas normal-size particles are found on the PF faces (Simpson *et al.*, 1978). In *Chlamydomonas* membranes deficient in PSII, a partial or nearly complete loss of the EF particles has been observed (Ladygin *et al.*, 1980; Wollman *et al.*, 1980).

In most of the previously mentioned studies, the data have been consistent with a model in which EF_s particles are composed of a core RC complex for PSII surrounded by aggregates of the LH complex (Armond *et al.*, 1977; Staehelin *et al.*, 1977; Arntzen, 1978). This concept has been challenged in studies by Simpson (1979) based upon analyses of a *chlorina-f2* mutant of barley. The EF_s particles in this mutant were found to be only about 12% smaller in diameter than those of the wild type (this corresponds to a larger percentage particle volume decrease). Since the mutant does not contain Chl *b*, it was assumed that this data was inconsistent with a portion of the size of the EF particles being due to the LH complex for PSII. In other studies, however, it has been established that the Chl *b*-less mutant of barley is missing only one of the two major polypeptides of the LH complex for PSII (Boardman *et al.*, 1978; Burke *et al.*, 1979). This is consistent with only a partial decrease in the size of the EF particles in the mutant.

Membrane studies, which have altered the organization of the chlo-

roplast thylakoid, also support the concept that the EF_S particles consist of both a core complex and associated LH pigment-protein units. In chloroplasts isolated from the leaves of *Nerium oleander*, Armond *et al.* (1980) studied high temperature-induced alteration of membrane structure. Quantitative analysis of electron micrographs obtained from freeze-fractured, treated membranes revealed that the EF particles were modified by heat pretreatment. The alterations primarily consisted of a decrease in the large size-class of EF particles (i.e., those particles which the researchers concluded to consist of both a core complex plus associated LH components). The decrease in the size of the EF particles corresponded to a change in LH efficiency of PSII and an increase in Chl *a* fluorescence associated with the LH complex. In total, these data indicated that structural and functional associations of the LH complex with the PSII core exist in unmodified membranes but can be altered in the heat-treated samples. A somewhat analogous set of observations has been provided by Siegel *et al.* (1981). These authors have induced fusion of liposomes with chloroplast membranes. The resultant lamellae expressed high chlorophyll fluorescence at 685 nm [derived from the LHC(II)*] and an altered membrane subunit structure. In particular, the size of the EF particles was reduced and crystalline aggregates of smaller subunits appeared on the PF fracture face. The authors concluded that phospholipid incorporation into the chloroplast thylakoid results in both a functional and structural disruption of LHC(II) association with the PSII core complex, thereby resulting in the production of small EF particles, which represent the remaining core of PSII, as well as free and functionally disassociated LH complexes that self-aggregate and fracture to the PF face of the membrane.

The structural model presented by Armond *et al.* (1977) implied that EF particles contained the RC polypeptides and associated enzymatic constituents of PSII, (i.e., the core complex), as well as *all* of the LH pigment-proteins serving PSII. This may have been an incorrect implication. The study of *Chlamydomonas* mutant membranes by Wollman *et al.* (1980) indicate that some of the LHC(II) is probably associated with PF particles. This is not as divergent a view as that expressed by Simpson (1979), who proposed that all LHC(II) is associated with PF particles and not the EF subunits.

The identification of EF particles as supermolecular complexes containing PSII RCs raises the question of the number of centers that exist per EF particle. This question has been carefully analyzed by Wollman *et*

*There appears to be some disagreement in the literature about the source of this fluorescence; it could also arise from the core of PSII—editor.

al. (1980). These authors have used Chl *a* fluorescence-induction transients to determine the interactions among PSII centers in wild type as well as mutant membranes that were partially depleted in PSII traps. Their data clearly favored the idea that there is only one PSII center per EF particle; the known interactions among PSII centers could thereby be explained if there were interactions between individual EF particles. This model was also supported in studies by Dubertret and Lefort-Tran (1981); measurement of PSII interactions in greening *Euglena* chloroplasts indicated that PSII units are organized as individual and discrete entities and the energy transfer among PSII units is only brought about by bringing particles into contact. It should be noted that this is consistent with the effect of cations upon intersystem II energy transfer (previously reviewed in Arntzen, 1978). In cation-depleted thylakoids, excitation energy transfer among PSII units is inhibited as chloroplast membrane unstacking occurs. Under these conditions, there is no disruption or reorganization within EF_s particles. However, physical separation of individual PSII reaction centers, each localized within the EF_s particles that disperse uniformly into the unstacked membranes, corresponds to a loss of functional interaction among the PSII centers.

In summary, existing data overwhelmingly indicates that EF particles of chloroplast membranes consist of a PSII core complex (RC polypeptides plus closely associated electron carriers) as well as some, but perhaps not all, of the LH pigment-protein [LHC(II)], which functions to absorb light energy and act as an antenna for the PSII complex.

2. THE PROTOPLASMIC FRACTURE FACE PARTICLES

Arntzen (1978) has pointed out that the biochemical identity of the PF particle was much more problematic than that of the EF particle. This remains true today. We can only present a summary of the possible approaches to correlation of structure and function with respect to this membrane component.

In early detergent fractionation studies, purified PSI fractions were found to contain only particles of the PF-size class, with no large EF particles. This led to the idea that the PF particles are morphological equivalents of PSI units (Arntzen *et al.*, 1969). This view was later broadened to suggest that PF particles actually represent a mixed population of several types of functional units including PSI units, the Cyt *b₆-f* complex, and the hydrophobic portion of the ATPase (Arntzen, 1978).

There are two distinct size classes of PF particles in most higher plant chloroplasts. These average 80–85 and 105 Å in diameter (Staehelin, 1976; Armond *et al.*, 1977; Staehelin *et al.*, 1977). The larger size class, which is localized in unstacked membranes, has been suggested to repre-

sent the core complex of PSI with an associated LH complex (Staehelin *et al.*, 1977), possibly the LHC(I). The large size class particles are not present in partially developed chloroplasts (Armond *et al.*, 1977) or in certain algal chloroplasts (Staehelin *et al.*, 1977; Giddings *et al.*, 1980).

Analysis of PSI-deficient mutants has supported the concept that some PF particles represent PSI structural units. In membrane samples deficient in the RC polypeptides, the number of PF particles was found to be reduced (Ladygin *et al.*, 1980).

As a final piece of evidence in favor of the idea that some PF particles are PSI centers, Mullet *et al.* (1980a) have examined purified PSI preparations reconstituted into liposomes; the observed particles averaged 106 Å, nearly the size of the large size class of PF particles.

The ratio of PF to EF particles in higher plant thylakoids has been reported to be approximately 3 : 1 (Staehelin, 1976). Since normal, mature chloroplasts have PSI-II ratios only slightly greater than unity (Melis and Brown, 1980), and since it is argued that one EF particle is equivalent to one PSII center (see the preceding section), it is evident that some PF particles must represent protein complexes other than PSI. Mullet *et al.* (1981c) have reconstituted the isolated CF₁-CF₀ complex into liposomes and observed a homogeneous population of 96 Å particles interrupting the lipid bilayer. These data could be interpreted to support a membrane model (Arntzen, 1978) in which a portion of the subunits of the PF face are the hydrophobic portion of the coupling factor.

The membrane model of Arntzen (1978) suggested that the Cyt *b*₆-*f* complex corresponds to a one-third portion of the PF particle population. Staehelin (personal communication) has recently examined the isolated, reconstituted protein complex in phospholipid vesicles and has observed 85 Å particles, which appear similar to PF particles. To date, no Cyt mutant or developmental system has been used for structural analysis relating to this particular concept.

As was discussed in the preceding section, some PF particles in partition regions may represent the LHC(II) (Simpson, 1979; Wollman *et al.*, 1980). The isolated, purified LHC(II), when reconstituted into lipid vesicles, was found to be a uniform population of 80 Å particles (Mullet and Arntzen, 1980). The factor(s) that control the structural fractionation of the LHC(II) with the PF face, as opposed to allowing it to remain associated with the core EF particle (Armond *et al.*, 1977) remains unknown.

In summary, particles of the PF fracture face appear to represent several functional constituents of the membrane including PSI, a Cyt *b*₆-*f* complex, the CF₀, and a portion of the population of LHC(II).

F. The Membrane Component Which Determines Grana Stacking

Arntzen (1978) has reviewed the now compelling evidence, which indicates that the LH Chl *a-b* protein, or its *in vivo* organized form as LHC(II), is required for grana stacking. Briefly, the observations supporting this statement are as follows. First, organisms or mutants which lack LHC(II) do not exhibit stacked thylakoids. This is true for the prokaryotic cyanobacteria (Giddings and Staehelin, 1979), with the exception of *Prochloron*, which does contain LHC(II) and grana (Giddings *et al.*, 1980). Developing chloroplasts form grana stacks in direct concert with the appearance of LHC(II) (Armond *et al.*, 1976; Argyroudi-Akoyunoglou, 1977). A Chl *b*-less barley mutant with a reduced complement of LHC(II) polypeptides has grana stacks of lowered stability (Burke *et al.*, 1979). Second, selective proteolytic alteration of the surface-exposed segments of the LHC(II) polypeptides in intact membranes blocks grana stacking (Gerola *et al.*, 1977; Jennings *et al.*, 1978; Steinback *et al.*, 1978, 1979). Third, a reconstituted LHC(II)-liposome system was found in initial studies (Steinback *et al.*, 1978) to undergo reversible, cation-dependent vesicle appression mimicking grana stacking. This observation has now been verified in several laboratories and warrants further discussion.

The grana stacking simulation experiments are diagrammed in Fig. 9.

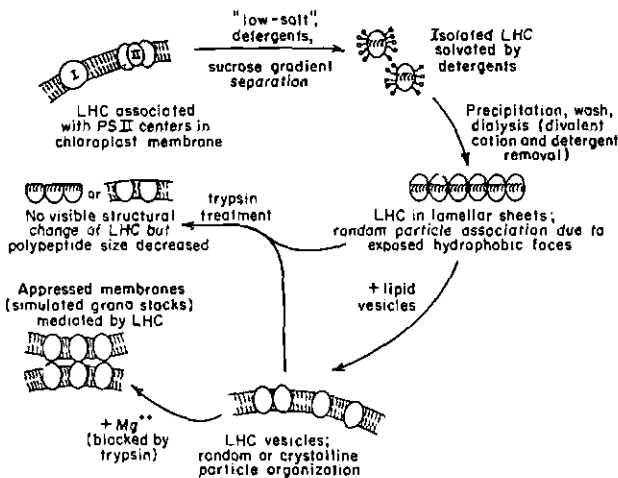

FIG. 9. A diagrammatic summary of the procedures used to isolate LH complex (LHC) of PSII and to reconstitute it into phospholipid vesicles that demonstrate cation-mediated membrane appression (simulated grana stacking). (Diagram is modified from Mullet and Arntzen, 1980.)

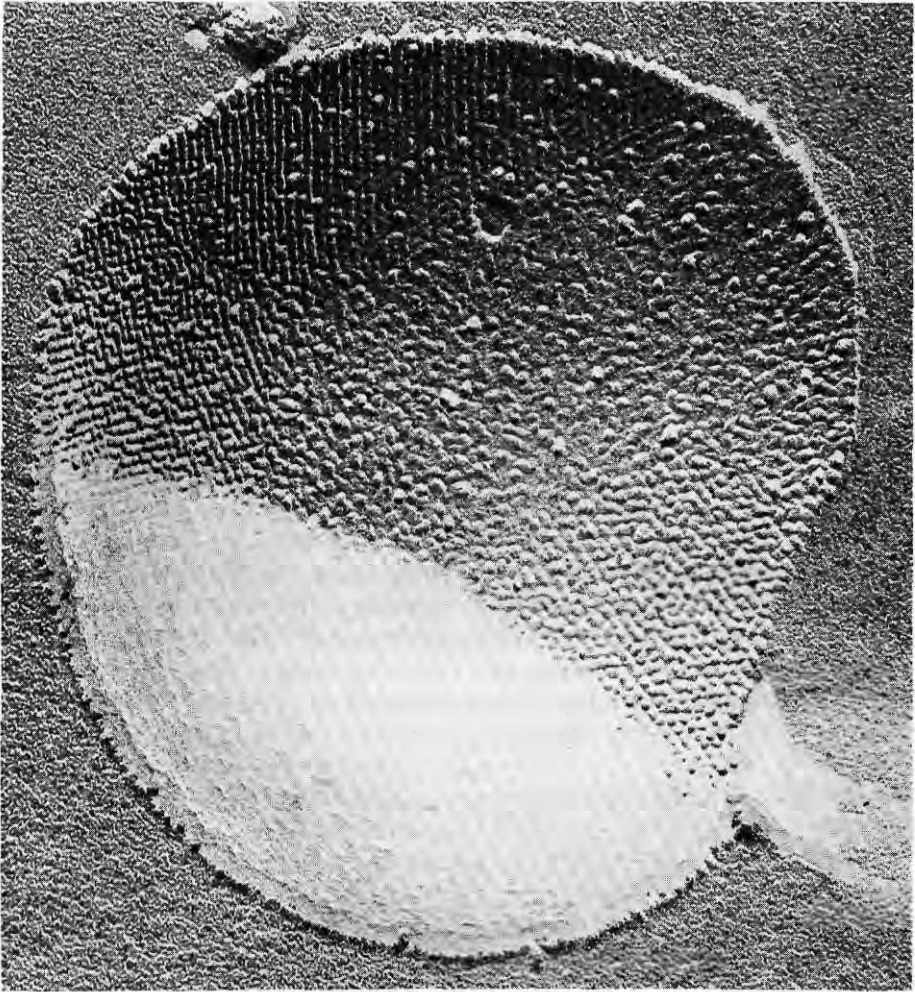

FIG. 10. An electron micrograph showing the freeze–fracture image of isolated LHC(II) reconstituted into a unilamellar phospholipid vesicle. The subunits visible in the membrane bilayer average 80 Å in diameter and represent one LHC(II) (i.e., the aggregate of 4–6 individual LH Chl *a-b* proteins plus associated pigments). (Micrograph courtesy of John Mullet.)

Light-harvesting complex II is isolated and purified by mild detergent techniques (start at the right top of the Fig.). The complexes are depleted of bound detergent to give rise to lamellar sheets of subunits which can then be introduced into lipid membranes. An example of such a preparation is shown in Fig. 10. Addition of cations to these reconstituted vesicles causes formation of appressed membranes (simulated

grana stacks) (McDonnell and Staehelin, 1980; Mullet and Arntzen, 1980; Rytie and Anderson, 1980). The stacking process cannot be induced by other reconstituted pigment proteins such as the PSI complex. With LHC(II) vesicles, stacking is irreversibly blocked by modification of the surface-exposed LHC(II) polypeptides by trypsin (Mullet and Arntzen, 1980). Model membranes, in which LHC(II) is the only functional constituent, can undergo cation-dependent, reversible "grana stacking."

G. The Function of Grana Stacking

It is now well documented that grana stacks are not a prerequisite for any aspect of electron transport or energy coupling activities of chloroplasts (Arntzen, 1978). (Cyanobacteria do not have grana and perform all reactions.) Evidence has also been provided to demonstrate that the stacking process, per se, is not directly correlated to cation-induced changes in the distribution of absorbed excitation energy between PSII and PSI, as measured by changes in Chl *a* fluorescence (Staehelin and Arntzen, 1979; Wollman and Diner, 1980), although the underlying mechanisms influencing both phenomena may be related (Mullet *et al.*, 1981a). The obvious question remaining is why the unique pattern of membrane appression should occur as a constant feature of all higher plant chloroplasts if it is not essential for any specific function. The most likely answer is that membrane appression allows a physical "sorting out" of membrane functional complexes to regulate interactions and thereby control the *efficiency* of LH and photochemical reactions. To elaborate upon this point, we must consider the mechanism of grana formation and the functional properties of components within and outside the stacked membrane regions.

1. THE MOLECULAR BASIS OF THYLAKOID ADHESION

Isolated chloroplast membranes have a net negative surface charge (Barber, 1979). The approach of two surfaces during formation of appressed membranes involves a balance of long-range repulsive forces and short-range attractive forces (primarily electrostatic and van der Waals, respectively). Barber and co-workers (see Barber, 1980) have noted that there is a nonspecific requirement for cations to bring about membrane appression. This has led to the idea that the stacking process requires a general electrostatic shielding, which is consistent with standard Gouy-Chapman theoretical treatments; this basic concept requires no specific chemical mechanism for membrane appression (Barber, 1980).

Scully *et al.* (1980) have also analyzed the electrostatic screening mech-

anisms which control stacking. They agree that cations are involved in charge screening, but argue that the 10–40 Å approach distances that must be achieved if grana stacking is to occur could not be achieved at physiological cation concentrations. To overcome this difficulty, they have proposed that negatively charged groups must move into unstacked membrane regions during the formation of stacked thylakoids.

Barber (1980) has also proposed that neutralization of surface charge would lead to formation of pigment–protein “domains” with the PSII–LHC(II) localized in grana partitions and PSI largely in the stroma lamellae. This conclusion was based, in part, upon measurements of the apparent lack of LHC(II) contribution to total membrane surface charge, since Nakatani *et al.* (1978) found that the Chl *b*-less barley mutant (which is partially deficient in LHC(II) polypeptides) did not have an appreciably different surface charge density than the wild-type membranes.

Rubin *et al.* (1981) have reanalyzed the theoretical and experimental data on cation-induced stacking. They state that a reduction in local surface charge density (to give a site of membrane adhesion) due to lateral diffusion alone is insufficient to realize grana stacking. They argue that an increase in van der Waals attractive forces must be necessary to stabilize adhesion.

A model by Mullet *et al.* (1981a) for the “contact mechanism” of grana stacking is consistent with the previously mentioned data of Rubin *et al.* (1981), as well as the lateral diffusion of membrane components during stacking. Mullet *et al.* recall that the mechanism regulating the stacking process must account for both the data with intact membranes and the LHC(II)–liposome system, both of which follow very similar cation dependencies. Second, they note the extensive data showing that a surface exposed segment of the LHC(II) polypeptides is *essential* for physiological membrane appression. Last, they recognize that the requirement for dispersal of negative charged components of the membrane into stroma lamellae (Barber, 1980; Scully *et al.*, 1980) must occur prior to stable membrane adhesion; the mechanism for this dispersal without adhesion is not evident.

Mullet *et al.* (1981a) have determined the amino acid composition of the surface-exposed segment of the LHC(II) polypeptide, which is removed by trypsin and which is required for grana stacking. It primarily contains positively charged amino acids (lysine and arginine). Since this positively charged polypeptide segment is externally exposed, it is accessible to an adjacent membrane and could, in fact, extend tens of Å out from the LHC(II). Mullet *et al.* therefore proposed that this segment is necessary for the stabilization of membrane–membrane interactions, which allow reorganization of charged groups along the membrane.

The principle features of the Mullet *et al.*'s "contact mechanism" are: (a) Cations are required to give electrostatic shielding to allow close approach of two membranes; and (b) surface-exposed, positively charged segments of LHC(II) bridge the space between approaching membranes and stabilize the association via van der Waals forces and/or electrostatic interaction. The key point of this model is that there is a chemical mechanism requirement. Since LHC(II) interacts with itself in model membrane systems (see Section III,F), it is likely that there is a specific association of the positively charged LHC(II) segment with another negatively charged region of the LHC(II) polypeptide "attachment site." This would be consistent with structural data in intact membranes which favors direct LHC-LHC interaction (Staehelin and Arntzen, 1979).

To review, existing evidence indicates that the formation of grana stacks requires cation shielding of net negative membrane surface charge, as well as specific interactions among LHC(II) polypeptides on opposing membranes. "Entropic ordering" of the associated LHC units (see Staehelin and Arntzen, 1979) and creation of domains with small or large negative surface charge (in grana or stroma lamellae, respectively) due to lateral displacement of protein complexes (see Barber, 1980) gives rise to enrichment of PSII in the grana and PSI in the stroma lamellae.

2. REGULATION OF ENERGY DISTRIBUTION BETWEEN PHOTOSYSTEM II AND I

The distribution of absorbed excitation energy between PSII and I can be experimentally manipulated by changing the cation concentration around isolated thylakoids (see Barber, 1976; Williams, 1977; Arntzen, 1978; Wong, 1979). In unstacked, "low-salt" chloroplasts there is preferential energy distribution to PSI. Readdition of cations causes grana stacking and a shift in energy distribution in favor of PSII. In addition, energy transfer among PSII particles was low or nonexistent in unstacked membranes but maximal in stacked membranes.

It has been hypothesized that the lateral distribution of the photosystems that occurs concomitantly with grana stacking is important in determining the probability of energy transfer among structural PS units (Arntzen, 1978; Barber, 1980). In the PSII-enriched partitions of stacked chloroplasts, inter PSII energy transfer would effectively compete for excitation energy loss to PSI. In addition, evidence has been presented for a cation-mediated change in physical coupling (Arntzen and Ditto, 1976) and functional coupling (Butler, 1978; Wong and Govindjee, 1981) of PSII core complexes and the LHC(II) as grana stacks

form. As described by Butler (1978; also see Wong *et al.*, 1981). The increase in functional coupling induced by cations will increase the rate of energy transfer between LHC(II) and PSII while decreasing energy transfer from PSII to PSI. Both concepts require the participation of LHC(II) and changing membrane properties associated with membrane stacking.

3. PHOSPHORYLATION OF LIGHT-HARVESTING COMPLEX (II) POLYPEPTIDES

For maximum efficiency of noncyclic electron transport, the two photosystems must operate in synchronization. This requires equal rates of excitation of the two RCs. In 1969, Murata, and Bonaventura and Myers independently gained evidence for an *in vivo* regulatory mechanism, which ensures this balanced pattern of excitation. The process is referred to as a "state" change process meaning that the pigment bed can alter in function to direct excitation energy to either of the photosystems. Only recently has the biochemical mechanism for this regulatory phenomenon been elucidated.

Bennet (1977, 1979, 1980), in an elegant series of papers, demonstrated that chloroplasts contain a membrane bound kinase and phosphatase, which catalyze the reversible phosphorylation of certain thylakoid proteins. The preferred substrate for these reactions was the surface exposed segment of LHC(II) (which has been demonstrated to function in grana stacking; see Section III,G,1). The activation of the kinase has been found to be dependent upon the oxidation-reduction state of the PQ pool (Fig. 11) (Horton and Black, 1980; Allen *et al.*, 1981). Under conditions where the PQ pool is reduced, the kinase is activated and phosphorylation of the LHC(II) polypeptides occurs. Re-oxidation of the PQ pool leads to kinase inactivation and subsequent dephosphorylation of the protein by the membrane-bound phosphatase.

The functional significance of the protein phosphorylation was revealed by Bennett *et al.* (1980). Phosphorylation of the LHC(II) proteins leads to an alteration in excitation energy distribution (that was not related to any alteration of cation concentrations). In the phosphorylated "state," excitation energy was preferentially directed to PSI. In dephosphorylated samples, energy was preferentially directed to PSII. The redox state of the electron transport chain connecting the two photosystems can therefore directly regulate the turnover rate of the two RCs via LHC(II) phosphorylation. It was proposed that this is the regulating mechanism by which plants adapt to changing wavelengths of light (Allen *et al.*, 1981).

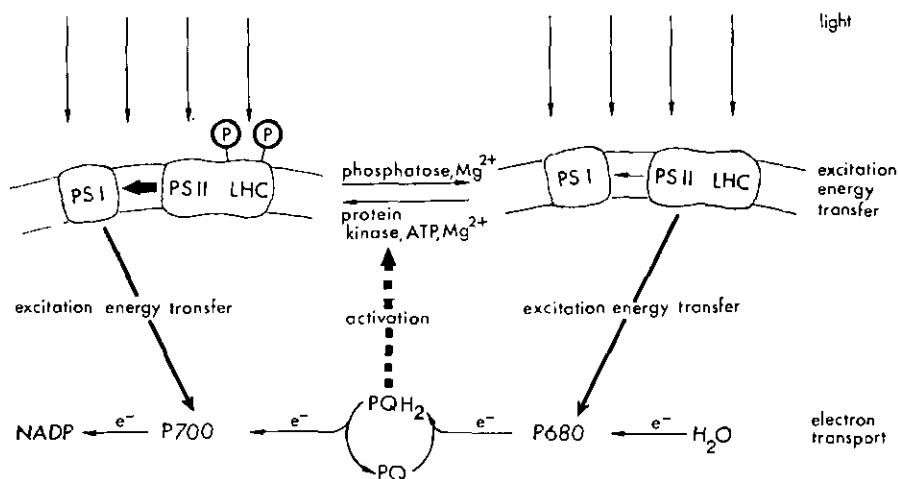

FIG. 11. A model for control of distribution of excitation energy in photosynthesis, in which reversible phosphorylation of LHC couples the redox state of plastoquinone (PQ) to the distribution of excitation energy between the two photosystems (PS I and PS II). The mechanism guarantees maximal quantum efficiency of noncyclic electron transport from water to NADP^+ , mediated by P680 and P700, the RCs of PS II and PS I, respectively. Reduction of PQ by PS II leads to kinase activation and LHC(II) phosphorylation. This, in turn, brings about increased excitation of PS I. Conversely, oxidation of PQH_2 inactivates the kinase; the phosphatase then dephosphorylates LHC(II) and hence excitation of PS II is increased relative to that of PS I. Since the redox state of PQ will be determined in part by the distribution of excitation energy between the two photosystems, reversible LHC(II) phosphorylation completes a feedback loop by means of which any imbalance in this distribution will tend to be self-correcting (after Allen *et al.*, 1981).

4. SUMMARY

The formation of grana stacks in higher plant chloroplasts is dependent upon the presence of LHC(II), and more specifically, upon the involvement of a positively charged, surface-exposed segment of the LHC(II) pigment proteins. Formation of grana stacks leads to an enrichment of PS II centers in the region of membrane appression, whereas PS I becomes enriched in the stroma lamellae. This distribution pattern of the functional pigment complexes influences the pattern of distribution of absorbed excitation energy.

Phosphorylation of the surface-exposed LHC(II) polypeptide, in response to reduction of the intersystem electron transport chain, causes an alteration in the properties of the pigment bed leading to increased PS I excitation. The function of grana stacks, therefore, is to establish a defined distribution of the individual structural complexes of PS I and PS II. This structural arrangement allows subtle regulatory control via

protein phosphorylation to ensure maximal efficiency of the two photosystems acting in series.

IV. Conclusions

In both photosynthetic bacteria and higher plant chloroplast membranes, the functional components that catalyze energy coupling reactions are organized as protein complexes. The identification of specific function for individual polypeptides is still at an early stage, but is progressing rapidly.

The pigment-proteins of bacteria display elaborate diversity. Certain water-soluble pigment-proteins have been well characterized. In contrast, the nature of pigment and protein association in lipophilic pigment-proteins of both bacteria and higher plants is poorly understood.

The similarity in structure and function of the cytochrome complex and the ATPase of bacteria and chloroplast membranes is very apparent; certain similar properties of bacterial RCs and chloroplast RCs are also becoming understood. The complexities and significance of membrane appression (grana stacking) in chloroplasts is now becoming evident; this feature serves to provide a structural order that permits the efficient operation of a two-step photosynthetic process in higher plants.

Acknowledgments

The authors would also like to thank those many investigators who provided information prior to publication. This research was supported in part, by DOE Contract DE-AC02-76ERO-1338 to C. J. A. and in part by grants from the NIH and NSF to S. Kaplan.

REFERENCES

- Aagaard, J., and Sistrom, W. R. (1972). *Photochem. Photobiol.* **15**, 209-225.
- Abdourakhmanov, I. A., Ganago, A. O., Erokhin, Y. E., Solov'ev, A. A., and Chugunov, V. A. (1979). *Biochim. Biophys. Acta* **546**, 183-186.
- Adams, M. W. W., and Hall, D. O. (1979). *Arch. Biochem. Biophys.* **195**, 288-299.
- Agalidis, I., Lutz, M., and Reiss-Husson, F. (1980). *Biochim. Biophys. Acta* **589**, 264-274.
- Allen, J. F., Bennett, J., Steinback, K. E., and Arntzen, C. J. (1981). *Nature (London)* **291**, 25-29.
- Amez, J. (1978). In "The Photosynthetic Bacteria" (R. K. Clayton and W. R. Sistrom, eds.), pp. 333-338. Plenum, New York.
- Anderson, J. M. (1981). *FEBS Lett.* **124**, 1-10.
- Andersson, B., and Anderson, J. M. (1980). *Biochim. Biophys. Acta* **546**, 426-439.

- Argyroudi-Akoyunoglou, J. H. (1977). In "Bioenergetics of Membranes" (L. Packer, G. Papageorgiou, and A. Trebst, eds.), pp. 85-96. Elsevier/North-Holland, Amsterdam.
- Armond, P. A., and Arntzen, C. J. (1977). *Plant Physiol.* **59**, 398-404.
- Armond, P. A., Arntzen, C. J., Briantais, J.-M., and Verrotte, C. (1976). *Arch. Biochem. Biophys.* **175**, 54-63.
- Armond, P. A., Staehelin, L. A., and Arntzen, C. J. (1977). *J. Cell Biol.* **73**, 400-418.
- Armond, P. A., Björkman, O., and Staehelin, L. A. (1980). *Biochim. Biophys. Acta* **601**, 433-442.
- Arntzen, C. J. (1978). *Curr. Top. Bioenerg.* **8**, 111-160.
- Arntzen, C. J., and Briantais, J.-M. (1975). In "Bioenergetics of Photosynthesis" (Govindjee, ed.), pp. 51-113. Academic Press, New York.
- Arntzen, C. J., and Ditto, C. L. (1976). *Biochim. Biophys. Acta* **449**, 259-274.
- Arntzen, C. J., Dilley, R. A., and Crane, F. L. (1969). *J. Cell Biol.* **43**, 16-31.
- Arntzen, C. J., Dilley, R. A., Peters, G. A., and Shaw, E. R. (1972). *Biochim. Biophys. Acta* **256**, 85-107.
- Arntzen, C. J., Armond, P. A., Briantais, J.-M., Burke, J. J., and Novitzky, W. P. (1977). *Brookhaven Symp. Biol.* **28**, 316-337.
- Baccarini-Melandri, A., and Melandri, B. A. (1977). *FEBS Lett.* **80**, 459-464.
- Baccarini-Melandri, A., Gest, H., and Pietro, A. S. (1970). *J. Biol. Chem.* **245**, 1224-1226.
- Baltscheffsky, M. (1977). In "Living Systems as Energy Converters" (R. Buvet, M. J. Allen, and J.-P. Massue, eds.), pp. 199-207. Elsevier/North-Holland, Amsterdam.
- Baltscheffsky, M. (1978). In "The Photosynthetic Bacteria" (R. K. Clayton and W. R. Sistrom, eds.), pp. 595-609. Plenum, New York.
- Baltscheffsky, H., and von Stedingk, L.-V. (1966). *Biochem. Biophys. Res. Commun.* **22**, 722-728.
- Barber, J. (1976). In "The Intact Chloroplast" (J. Barber, ed.), Vol. 1, pp. 89-134. Elsevier/North-Holland Biomedical Press, Amsterdam.
- Barber, J. (1979). *Ciba Found. Symp. (N.S.)* **61**, 283-304.
- Barber, J. (1980). *FEBS Lett.* **118**, 1-10.
- Barrett, J., and Jones, O. T. G. (1978). *Biochem. J.* **174**, 277-281.
- Bengis, C., and Nelson, N. (1975). *J. Biol. Chem.* **250**, 2783-2788.
- Bengis, C., and Nelson, N. (1977). *J. Biol. Chem.* **252**, 4564-4569.
- Bengis-Garber, C., and Gromet-Elhanan, Z. (1979). *Biochemistry* **18**, 3577-3581.
- Bennett, J. (1977). *Nature (London)* **269**, 344-346.
- Bennett, J. (1979). *Eur. J. Biochem.* **99**, 133-137.
- Bennett, J. (1980). *Eur. J. Biochem.* **104**, 84-89.
- Bennett, J., Steinback, K., and Arntzen, C. J. (1980). *Proc. Natl. Acad. Sci. U.S.A.* **77**, 5253-5257.
- Bergeron, J. A., and Fuller, R. C. (1961). In "Biological Structure and Function" (T. W. Goodwin and O. Lindberg, eds.), Vol. 2, pp. 307-324. Academic Press, New York.
- Birrell, G. B., Sistrom, W. R., and Griffith, O. H. (1978). *Biochemistry* **17**, 3768-3773.
- Boardman, N. K., and Anderson, J. M. (1964). *Nature (London)* **203**, 166-170.
- Boardman, N. K., Anderson, J. M., and Goodchild, D. J. (1978). *Curr. Top. Bioenerg.* **8**, 35-109.
- Bolt, J., and Sauer, K. (1979). *Biochim. Biophys. Acta* **546**, 54-63.
- Bonaventura, C., and Myers, J. (1969). *Biochim. Biophys. Acta* **189**, 366-383.
- Bothwell, H. A., Howlett, G. J., and Schachman, H. K. (1978). *J. Biol. Chem.* **253**, 2073-2077.
- Boucher, F., van der Rest, M., and Gingras, G. (1977). *Biochim. Biophys. Acta* **461**, 339-357.
- Bowyer, J. R., and Crofts, A. R. (1978). *Front. Biol. Energ.* **1**, 326-333.

- Bowyer, J. R., Tierney, G. V., and Crofts, A. R. (1979). *FEBS Lett.* **101**, 207–212.
- Branton, D., and Deamer, D. W. (1972). In "Protoplasmatologia" (M. Alfert, H. Bauer, W. Sandritter, and P. Sitte, eds.), pp. 1–70. Springer-Verlag, Berlin and New York.
- Branton, D., Bullivant, S., Gilula, N. B., Karnovsky, M. J., Moor, H., Mühlethaler, K., Northcote, D. H., Packer, L., Saitir, B., Saitir, P., Speth, V., Staehelin, L. A., Steere, R. L., and Weinstein, R. S. (1975). *Science* **190**, 54–56.
- Brogie, R. M., Hunter, C. N., Delepelair, P., Niederman, R. A., Chua, N.-H., and Clayton, R. K. (1980). *Proc. Natl. Acad. Sci. U.S.A.* **77**, 87–91.
- Buchanan, B. B., and Evans, M. C. W. (1969). *Biochim. Biophys. Acta* **180**, 123–129.
- Burke, J. J., Ditto, C. L., and Arntzen, C. J. (1978). *Arch Biochem. Biophys.* **187**, 252–263.
- Burke, J. J., Steinback, K. E., and Arntzen, C. J. (1979). *Plant Physiol.* **63**, 237–243.
- Butler, W. L. (1978). *Annu. Rev. Plant Physiol.* **29**, 354–378.
- Cain, B., Deal, C., Fraley, R., and Kaplan, S. (1981). *J. Bacteriol.* **145**, 1154–1166.
- Carithers, R. P., and Parson, W. W. (1975). *Biochim. Biophys. Acta* **387**, 194–211.
- Carithers, R. P., Yoch, D. C., and Arnon, D. I. (1977). *J. Biol. Chem.* **252**, 7461–7467.
- Carmeli, C., and Racker, E. (1973). *J. Biol. Chem.* **248**, 8281–8287.
- Cellarius, R. A., and Peters, G. A. (1969). *Biochim. Biophys. Acta* **189**, 234–244.
- Chua, N.-H., and Bennoun, P. (1975). *Proc. Natl. Acad. Sci. U.S.A.* **72**, 2175–2179.
- Chua, N.-H., and Blomberg, F. (1979). *J. Biol. Chem.* **254**, 215–223.
- Clayton, B. J., and Clayton, R. K. (1978). *Biochim. Biophys. Acta* **501**, 470–477.
- Clayton, R. K. (1962). *Biochem. Biophys. Res. Commun.* **9**, 49–53.
- Clayton, R. K. (1963). *Biochim. Biophys. Acta* **75**, 312–323.
- Clayton, R. K. (1978). In "Photosynthetic Bacteria" (R. K. Clayton and W. R. Sistrom, eds.), pp. 387–394. Plenum, New York.
- Clayton, R. K., and Clayton, B. J. (1972). *Biochim. Biophys. Acta* **283**, 492–504.
- Clayton, R. K., and Haselkorn, R. (1972). *J. Mol. Biol.* **68**, 97–105.
- Clayton, R. K., and Wang, R. T. (1971). In "Methods in Enzymology" (A. San Pietro, ed.), Vol. 23, pp. 696–704. Academic Press, New York.
- Cogdell, R. J., and Crofts, A. R. (1978). *Biochim. Biophys. Acta* **502**, 409–416.
- Cogdell, R. J., and Thornhor, J. P. (1979). *Ciba Found. Symp.* [N.S.] **61**, 61–79.
- Cogdell, R. J., Jackson, J. B., and Crofts, A. R. (1972). *J. Bioenerg.* **4**, 211–227.
- Cogdell, R. J., Brune, D. C., and Clayton, R. K. (1974). *FEBS Lett.* **45**, 344–347.
- Cogdell, R. J., Parson, W. W., and Kerr, M. A. (1976). *Biochim. Biophys. Acta* **430**, 83–93.
- Cohen, L. K., and Kaplan, S. (1981a). *J. Biol. Chem.* **256**, 5901–5908.
- Cohen, L. K., and Kaplan, S. (1981b). *J. Biol. Chem.* **256**, 5909–5915.
- Cohen-Bazire, G., Pfennig, N., and Kunisawa, R. (1964). *J. Cell Biol.* **22**, 207–225.
- Collins, M. L. P., and Niederman, R. A. (1976). *J. Bacteriol.* **126**, 1326–1338.
- Collins, M. L. P., Mallon, D. E., and Niederman, R. A. (1979). *J. Bacteriol.* **139**, 1089–1092.
- Crofts, A. R. (1970). In "Electron Transport and Energy Conservation" (J. M. Tager, S. Papa, E. Quagliariello, and E. C. Slater, eds.), pp. 221–228. Adriatica Editrice, Bari, Italy.
- Crofts, A. R. (1979). In "Light-Induced Charge Separation in Biology and Chemistry" (H. Gerischer and J. J. Katz, eds.), pp. 389–410. Verlag Chemie, Weinheim.
- Crofts, A. R., and Bowyer, J. (1977). In "The Proton and Calcium Pumps" (G. F. Azzone, M. Avron, J. C. Metcalfe, E. Quagliariello, and N. Siliprandi, eds.), pp. 55–64. Elsevier/North-Holland, Amsterdam.
- Crofts, A. R., Crowther, D., Bowyer, J., and Tierney, G. V. (1977). In "Structure and Function of Energy Transducing Membranes" (K. Van Dam and B. F. Van Gelder, eds.), pp. 139–155. Elsevier/North-Holland, Amsterdam.
- Cuendet, P. A., and Zuber, H. (1977). *FEBS Lett.* **79**, 96–100.

- Cuendet, P. A., Zürrer, H., Snozzi, M., and Zuber, H. (1978). *FEBS Lett.* **88**, 309–312.
- Cullis, P. R., and De Kruijff, B. (1979). *Biochim. Biophys. Acta* **559**, 399–420.
- Cusanovich, M. A., and Kamen, M. D. (1968). *Biochim. Biophys. Acta* **153**, 376–396.
- Davis, K. A., Hatefi, Y., Crawford, I. P., and Baltscheffsky, H. (1977). *Arch. Biochem. Biophys.* **180**, 459–464.
- Deleplaire, P., and Chua, N.-H. (1979). *Proc. Natl. Acad. Sci. U.S.A.* **76**, 111–115.
- Diner, B. A., and Bowes, J. M. (1981). *Proc. Int. Congr. Photosyn., 5th, 1980* pp. 875–884.
- Diner, B. A., and Wollman, F. A. (1980). *Eur. J. Biochem.* **110**, 521–526.
- Donohue, T. J., Cain, B. D., and Kaplan, S. (1982). *Biochemistry* **21**, 2765–2773.
- Drews, G. (1978). *Curr. Top. Bioenerg.* **8**, 161–207.
- Drews, G., and Oelze, J. (1981). *Adv. Microb. Physiol.* **22**, 1–92.
- Dubertret, G., and Lefort-Tran, M. (1981). *Biochim. Biophys. Acta* **634**, 52–69.
- Dutton, P. L., and Prince, R. C. (1978). In "The Photosynthetic Bacteria" (R. K. Clayton and W. R. Sistrom, eds.), pp. 439–450. Plenum, New York.
- Dutton, P. L., Petty, K. M., Bonner, H. S., and Morse, S. D. (1975). *Biochim. Biophys. Acta* **387**, 536–556.
- Dutton, P. L., Prince, R. C., Tiede, D. M., Petty, K. M., Kaufmann, K. J., Netzel, T. L., and Rentzepis, P. M. (1977). *Brookhaven Symp. Biol.* **28**, 213–237.
- Duysens, L. N. M. (1954). *Nature (London)* **173**, 692–693.
- Edelman, M., and Reinfeld, A. (1980). In "Genome Organization and Expression in Plants" (C. J. Leaver, ed.), pp. 353–362. Plenum, New York.
- Elferink, M. G. L., Hellingwerf, K. J., Michels, P. A. M., Seyen, H. G., and Konings, W. N. (1979). *FEBS Lett.* **107**, 300–307.
- Emerson, R., and Arnold, W. (1932). *J. Gen. Physiol.* **16**, 191–195.
- Evans, E. H., and Crofts, A. R. (1974). *Biochim. Biophys. Acta* **357**, 89–102.
- Evans, M. C. W., Lord, A. V., and Reeves, S. G. (1974). *Biochem. J.* **138**, 177–183.
- Feher, G. (1971). *Photochem. Photobiol.* **14**, 373–387.
- Feher, G., and Okamura, M. Y. (1977). *Brookhaven Symp. Biol.* **28**, 183–194.
- Feher, G., and Okamura, M. Y. (1978). In "The Photosynthetic Bacteria" (R. K. Clayton and W. R. Sistrom, eds.), pp. 349–382. Plenum, New York.
- Feick, R., and Drews, G. (1978). *Biochim. Biophys. Acta* **501**, 499–513.
- Feick, R., and Drews, G. (1979). *Z. Naturforsch., C: Biosci.* **34C**, 196–199.
- Fowler, C. F., Nugent, N. A., and Fuller, R. C. (1971). *Proc. Natl. Acad. Sci. U.S.A.* **68**, 2278–2282.
- Fraker, P. J., and Kaplan, S. (1971). *J. Bacteriol.* **108**, 465–473.
- Fraker, P. J., and Kaplan, S. (1972). *J. Biol. Chem.* **247**, 2732–2737.
- Fraley, R. T., Jameson, D. M., and Kaplan, S. (1978a). *Biochim. Biophys. Acta* **511**, 52–69.
- Fraley, R. T., Lueking, D. R., and Kaplan, S. (1978b). *J. Biol. Chem.* **253**, 458–464.
- Fraley, R. T., Lueking, D. R., and Kaplan, S. (1979a). *J. Biol. Chem.* **254**, 1980–1986.
- Fraley, R. T., Yen, G. S. L., Lueking, D. R., and Kaplan, S. (1979b). *J. Biol. Chem.* **254**, 1987–1991.
- Frank, H. A., Bolt, J., Friesner, R., Nairn, J. A., Dismukes, G. C., and Sauer, K. (1979a). *Biochim. Biophys. Acta* **547**, 484–501.
- Frank, H. A., Bolt, J., Friesner, R., and Sauer, K. (1979b). *Biochim. Biophys. Acta* **547**, 502–511.
- Frenkel, A. W. (1954). *J. Am. Chem. Soc.* **76**, 5568–5569.
- Fuller, R. C., and Boyce, C. (1976). In "Proceedings of the Second International Symposium on Photosynthetic Procarvates" (G. A. Codd and W. D. P. Stewart, eds.), pp. 61–63. Ciba Foundation Symposium 61 (new series), Dundee, Scotland.
- Futai, M., Sternweis, P. C., and Heppel, L. A. (1974). *Proc. Natl. Acad. Sci. U.S.A.* **71**, 4213–4216.

- Gantt, E., Lipschultz, C. A., and Zilinskas, B. A. (1977). *Brookhaven Symp. Biol.* **28**, 347-357.
- Garcia, A., Vernon, L. P., and Mollenhauer, H. (1966a). *Biochemistry* **5**, 2399-2407.
- Garcia, A., Vernon, L. P., and Mollenhauer, H. (1966b). *Biochemistry* **5**, 2408-2416.
- Garcia, A., Vernon, L. P., Ke, B., and Mollenhauer, H. (1968). *Biochemistry* **7**, 319-325.
- Garcia, A., Drews, G., and Kamen, M. D. (1974). *Proc. Natl. Acad. Sci. U.S.A.* **71**, 4213-4216.
- Garcia, A., Drews, G., and Kamen, M. D. (1975). *Biochim. Biophys. Acta* **387**, 129-134.
- Garewal, H. S., and Wasserman, A. R. (1974). *Biochemistry* **13**, 4072-4079.
- Gepshtein, A., and Carmeli, C. (1974). *Eur. J. Biochem.* **44**, 593-602.
- Gepshtein, A., and Carmeli, C. (1978). *FEBS Lett.* **85**, 219-223.
- Gerola, P., DeBenedetti, E., Rizzi, S., Forti, G., and Garlaschi, F. M. (1977). In "Bioenergetics of Membranes" (L. Packer, G. Papageorgiou, and A. Trebst, eds.), pp. 85-96. Elsevier/North-Holland, Amsterdam.
- Giddings, T. H., and Staehelin, L. A. (1979). *Biochim. Biophys. Acta* **546**, 373-382.
- Giddings, T. H., Withers, N. W., and Staehelin, L. A. (1980). *Proc. Natl. Acad. Sci. U.S.A.* **77**, 352-356.
- Gingras, G. (1978). In "The Photosynthetic Bacteria" (R. K. Clayton and W. R. Sistrom, eds.), pp. 119-129. Plenum, New York.
- Gingras, G., and Jolchine, G. (1969). *Prog. Photosyn. Res., Proc. Int. Congr. [1st], 1968* Vol. 1, pp. 209-216.
- Girard, J., Chua, N.-H., Bennoun, P., Schmidt, G., and Delosome, M. (1980). *Current Genetics* **2**, 215-221.
- Gitlitz, P. H., and Krasna, A. I. (1975). *Biochemistry* **14**, 2561-2568.
- Gloe, A., and Pfennig, N. (1974). *Arch. Microbiol.* **96**, 93-101.
- Gloe, A., Pfennig, N., Brockmann, H., Jr., and Trowitzsch, W. (1975). *Arch. Microbiol.* **102**, 103-109.
- Gogotov, I. N., Zorin, N. A., Serebriakova, L. T., and Kondratieva, E. N. (1978). *Biochim. Biophys. Acta* **523**, 335-343.
- Golecki, J. R., and Oelze, J. (1975). *J. Gen. Microbiol.* **88**, 253-258.
- Golecki, J. R., Drews, G., and Bühler, R. (1979). *Cytobiologie* **18**, 381-389.
- Govindjee, ed. (1982). "Photosynthesis: Development, Carbon Metabolism, and Plant Productivity." Vol. II. Academic Press, New York.
- Govindjee, and Govindjee, R. (1975). In "Bioenergetics of Photosynthesis" (Govindjee, ed.), pp. 1-50. Academic Press, New York.
- Guillotou, J., and Reiss-Husson, F. (1975). *Arch. Microbiol.* **105**, 269-275.
- Haehnel, W., Pröpper, A., and Krause, H. (1980). *Biochim. Biophys. Acta* **593**, 384-399.
- Hales, B. J., and Gupta, A. D. (1979). *Biochim. Biophys. Acta* **548**, 276-286.
- Hall, R. L., Kung, M. C., Fu, M., Hales, B. J., and Loach, P. A. (1973). *Photochem. Photobiol.* **18**, 505-520.
- Hall, R. L., Doorley, P. F., and Niederman, R. A. (1978). *Photochem. Photobiol.* **28**, 273-276.
- Halsey, Y. D., and Byers, B. (1975). *Biochim. Biophys. Acta* **387**, 349-367.
- Halsey, Y. D., and Parson, W. W. (1974). *Biochim. Biophys. Acta* **347**, 404-416.
- Hatefi, Y., and Stiggal, D. L. (1976). *Enzymes* **13**, 175-297.
- Hatefi, Y., Davis, K. A., Baltscheffsky, H., Baltscheffsky, M., and Johansson, B. C. (1972). *Arch. Biochem. Biophys.* **152**, 613-618.
- Hauska, G. (1980). *FEBS Lett.* **119**, 232-234.
- Hauska, G., Samoray, D., Orlich, G., and Nelson, N. (1980). *Eur. J. Biochem.* **111**, 535-543.
- Hauska, G., Orlich, G., Samoray, D., Hurt, E., and Sane, P. V. (1981). *Proc. Int. Congr. Photosynth., 5th, 1980* pp. 903-914.
- Haworth, P., Breton, J., and Arntzen, C. J. (1981). *Plant Physiol.* **67**, Suppl.; Book of Abstracts, 30.

- Hedrick, J. J., and Smith, A. J. (1968). *Arch. Biochem. Biophys.* **126**, 155-164.
- Hiller, R. G., Møller, B. L., and Høyer-Hansen, G. (1980). *Carlsberg Res. Commun.* **45**, 315-328.
- Hochman, A., Fridberg, I., and Carmeli, C. (1975). *Eur. J. Biochem.* **58**, 65-72.
- Holmqvist, O. (1979). *FEMS Lett.* **6**, 37-40.
- Holt, S. C., and Marr, A. G. (1965). *J. Bacteriol.* **89**, 1413-1420.
- Holt, S. C., Truper, H. G., and Takacs, B. J. (1968). *Arch. Mikrobiol.* **62**, 111-128.
- Horton, P., and Black, M. T. (1980). *FEBS Lett.* **119**, 141-144.
- Høyer-Hansen, G. (1980). *Carlsberg Res. Commun.* **45**, 167-176.
- Hunter, C. N., and Jones, O. T. G. (1979a). *Biochim. Biophys. Acta* **545**, 325-338.
- Hunter, C. N., and Jones, O. T. G. (1979b). *Biochim. Biophys. Acta* **545**, 339-351.
- Hurlbert, R. E., Golecki, J. R., and Drews, G. (1974). *Arch. Microbiol.* **101**, 169-186.
- Hurt, E., and Hauska, G. (1981). *Eur. J. Biochem.* **117**, 591-599.
- Ingledeu, W. J., and Prince, R. C. (1977). *Arch. Biochem. Biophys.* **178**, 303-307.
- Ikegami, J. (1976). *Biochim. Biophys. Acta* **449**, 245-258.
- Jackson, J. B., and Crofts, A. R. (1969). *FEBS Lett.* **4**, 185-189.
- Jacobs, E., Heriot, K., and Fisher, R. R. (1977). *Arch. Microbiol.* **115**, 151-156.
- Jennings, R. C., Forti, G., Gerola, P. D., and Garlaschi, F. M. (1978). *Plant Physiol.* **62**, 879-884.
- Johansson, B. C., and Baltscheffsky, M. (1975). *FEBS Lett.* **53**, 221-224.
- Johansson, B. C., Baltscheffsky, M., and Baltscheffsky, H. (1972). *Photosynth., Two Centuries Its Discovery Joseph Priestley, Proc. Int. Congr. Photosynth. Res., 2nd, 1971*, pp. 1203-1209.
- Jolchine, G., and Reiss-Husson, F. (1974). *FEBS Lett.* **40**, 5-8.
- Jolchine, G., and Reiss-Husson, F. (1975). *FEBS Lett.* **52**, 33-36.
- Jones, O. T. G. (1977). *Symp. Soc. Gen. Microbiol.* Number 27, 151-183.
- Jones, O. T. G., and Plewis, K. W. (1974). *Biochim. Biophys. Acta* **357**, 204-214.
- Jones, O. T. G., and Saunders, V. A. (1972). *Biochim. Biophys. Acta* **275**, 427-436.
- Kaplan, S. (1978). In "The Photosynthetic Bacteria" (R. K. Clayton and W. R. Sistrom, eds.), pp. 809-835. Plenum, New York.
- Ke, B., Sugahara, K., and Shaw, E. R. (1975). *Biochim. Biophys. Acta* **408**, 12-25.
- Ke, B., Dolan, E., Sugahara, K., Hawkrige, F. M., Demeter, S., and Shaw, E. R. (1977). *Plant Cell Physiol., Spec. Issue* **3**, 187-189.
- Keister, D. L., and Yike, N. J. (1967). *Arch. Biochem. Biophys.* **121**, 415-422.
- Kendall-Tobias, M. (1980). Ph.D. Thesis, University of Bristol, United Kingdom.
- Kenyon, C. N. (1978). In "The Photosynthetic Bacteria" (R. K. Clayton and W. R. Sistrom, eds.), pp. 281-310. Plenum, New York.
- Kirk, J. T. O., and Tilney-Bassett, R. A. E. (1978). "The Plastids." Elsevier/North-Holland, Amsterdam.
- Knaff, D. D., and Malkin, R. (1976). *Biochim. Biophys. Acta* **430**, 244-252.
- Kopp, F., Cuendet, P. A., Mühlethaler, K., and Zuber, H. (1979). *Biochim. Biophys. Acta* **553**, 438-449.
- Kuntz, I. D., Jr., Loach, P. A., and Calvin, M. (1964). *Biophys. J.* **4**, 227-249.
- Lach, H. J., and Böger, P. (1977). *Z. Naturforsch., C: Biosci.* **32C**, 877-879.
- Ladygin, V. G., Semenova, G. A., and Tageeva, S. V. (1980). *Fiziol. Rast. (Moscow)* **27**, 91-97.
- Lascelles, J. (1968). *Adv. Microb. Physiol.* **2**, 1-42.
- Leigh, J. S., Jr. (1978). In "The Photosynthetic Bacteria" (R. K. Clayton and W. R. Sistrom, eds.), pp. 431-436. Plenum, New York.
- Lester, R. L., and Crane, F. L. (1959). *J. Biol. Chem.* **234**, 2169-2175.
- Leto, K. J., and Miles, D. (1980). *Plant Physiol.* **66**, 18-24.
- Lin, L., and Thornber, J. P. (1975). *Photochem. Photobiol.* **22**, 37-40.

- Loach, P. A. (1980). In "Methods in Enzymology" (A. San Pietro, ed.), Vol. 69, pp. 155-171. Academic Press, New York.
- Loach, P. A., Sekura, D. L., Hadsell, R. M., and Stemer, A. (1970). *Biochemistry* **9**, 724-733.
- Lommen, M. A. J., and Takemoto, J. (1978a). *Arch. Microbiol.* **118**, 305-308.
- Lommen, M. A. J., and Takemoto, J. (1978b). *J. Bacteriol.* **136**, 730-741.
- Lücke, F.-K., and Klemme, J.-H. (1976). *Z. Naturforsch., C: Biosci.* **31C**, 272-279.
- Lueking, D. R., Fraley, R. T., and Kaplan, S. (1978). *J. Biol. Chem.* **253**, 451-457.
- McDonnell, A., and Staehelin, L. A. (1980). *J. Cell Biol.* **84**, 40-56.
- Machold, O., Simpson, D. J., and Lindberg Møller, B. (1979). *Carlsberg Res. Commun.* **44**, 235-254.
- Marinetti, T. D., Okamura, M. Y., and Feher, G. (1979). *Biochemistry* **18**, 3126-3133.
- Matoo, A. K., Pick, U., Hoffman-Falk, H., and Edelman, M. (1981). *Proc. Natl. Acad. Sci. U.S.A.* **78**, 1572-1576.
- Matsuura, K., and Nishimura, M. (1977). *Biochim. Biophys. Acta* **462**, 700-705.
- Matthews, B. W., and Fenna, R. E. (1980). *Acc. Chem. Res.* **13**, 309-353.
- Matthews, B. W., Fenna, R. E., Bolognesi, M. C., Schmid, M. F., and Olson, J. M. (1979). *J. Mol. Biol.* **131**, 259-285.
- Melandri, A. B., and Zannoni, D. (1978). *J. Bioenerg. Biomembr.* **10**, 109-138.
- Melis, A., and Brown, J. S. (1980). *Proc. Natl. Acad. Sci. U.S.A.* **77**, 4712-4716.
- Michels, P. A. M., and Konings, W. N. (1978). *Biochim. Biophys. Acta* **507**, 353-368.
- Miller, K. R., and Cushman, R. A. (1979). *Biochim. Biophys. Acta* **546**, 481-497.
- Miller, K. R., and Staehelin, L. A. (1976). *J. Cell Biol.* **68**, 30-47.
- Mitchell, P. (1966). *Biol. Rev. Cambridge Philos. Soc.* **41**, 445-502.
- Miyake, J., Ochiai-Yanagi, S., Kasumi, T., and Takagi, T. (1978). *J. Biochem. (Tokyo)* **83**, 1679-1686.
- Møller, B. L., Smillie, R. M., and Høyer-Hansen, G. (1980). *Carlsberg Res. Commun.* **45**, 87-99.
- Monger, T. G., and Parson, W. W. (1977). *Biochim. Biophys. Acta* **460**, 393-407.
- Moskalenko, A. A., and Erokhin, Y. E. (1978). *FEBS Lett.* **87**, 254-256.
- Moudrianakis, E. N. (1968). *Fed. Proc., Fed. Am. Soc. Exp. Biol.* **27**, 1180.
- Müller, H. W., and Baltscheffsky, M. (1979). *Z. Naturforsch., C: Biosci.* **34C**, 229-232.
- Mullet, J. E., and Arntzen, C. J. (1980). *Biochim. Biophys. Acta* **589**, 100-117.
- Mullet, J. E., Burke, J. J., and Arntzen, C. J. (1980a). *Plant Physiol.* **65**, 814-822.
- Mullet, J. E., Burke, J. J., and Arntzen, C. J. (1980b). *Plant Physiol.* **65**, 823-827.
- Mullet, J. E., Leto, K., and Arntzen, C. J. (1981a). *Proc. Int. Congr. Photosynth., 5th, 1980* pp. 557-568.
- Mullet, J. E., Pick, U., and Arntzen, C. J. (1981b). *Biochim. Biophys. Acta* **642**, 149-157.
- Mullet, J. E., Baldwin, T. O., and Arntzen, C. J. (1981c). *Proc. Int. Congr. Photosynth., 5th, 1980* pp. 577-582.
- Murata, N. (1969). *Biochim. Biophys. Acta* **189**, 171-181.
- Nakatani, H. Y., Barber, J., and Forrester, J. A. (1978). *Biochim. Biophys. Acta* **504**, 215-225.
- Nelson, N., and Natsani, B. (1977). In "Bioenergetics of Membranes" (L. Packer, G. Akoyonoglou, and A. Trebst, eds.), pp. 233-244. Elsevier/North-Holland, Amsterdam.
- Nelson, N., and Neumann, J. (1972). *J. Biol. Chem.* **247**, 1817-1824.
- Nelson, N., Eyton, E., Natsani, B. E., Sigrist, H., Sigrist-Nelson, K., and Gitler, C. (1977). *Proc. Natl. Acad. Sci. U.S.A.* **74**, 2375-2378.
- Netzel, T. L., Rentzepis, P. M., and Leigh, J. (1973). *Science* **182**, 238-241.
- Niederman, R. A., and Gibson, K. D. (1978). In "The Photosynthetic Bacteria" (R. K. Clayton and W. R. Sistrom, eds.), pp. 79-113. Plenum, New York.

- Nieth, K. F., Drews, G., and Feick, R. (1975). *Arch. Microbiol.* **105**, 43–45.
- Nishi, N., Kataoka, M., Soe, G., Kakuno, T., Ueki, T., Yamashita, J., and Horio, T. (1979). *J. Biochem. (Tokyo)* **86**, 1211–1224.
- Noël, H., van der Rest, M., and Gingras, G. (1972). *Biochim. Biophys. Acta* **275**, 219–230.
- Nordlund, S., and Eriksson, U. (1979). *Biochim. Biophys. Acta* **547**, 429–437.
- Norris, J. R., and Katz, J. J. (1978). In "The Photosynthetic Bacteria" (R. K. Clayton and W. R. Sistrom, eds.), pp. 397–416. Plenum, New York.
- Oelze, J. (1978). *Biochim. Biophys. Acta* **509**, 450–461.
- Oelze, J., and Drews, G. (1972). *Biochim. Biophys. Acta* **265**, 209–239.
- Ogawa, T., Obata, F., and Shibata, K. (1966). *Biochim. Biophys. Acta* **112**, 223–234.
- Ojakian, G. K., and Satir, P. (1974). *Proc. Natl. Acad. Sci. U.S.A.* **21**, 2052–2056.
- Okamura, M. Y., Steiner, L. A., and Feher, G. (1974). *Biochemistry* **13**, 1394–1403.
- Okamura, M. Y., Isaacson, R. A., and Feher, G. (1975). *Proc. Natl. Acad. Sci. U.S.A.* **72**, 3491–3495.
- Okayama, S., Yamamoto, N., Nishikawa, K., and Horio, T. (1968). *J. Biol. Chem.* **243**, 2995–2999.
- Olive, J., Wollman, F. A., Bennoun, P., and ReCouver, M. (1979). *Mol. Biol. Rep.* **5**, 139–143.
- Olson, J. M. (1978). In "The Photosynthetic Bacteria" (R. K. Clayton and W. R. Sistrom, eds.), pp. 161–177. Plenum, New York.
- Olson, J. M., and Thorner, J. P. (1979). In "Membrane Proteins in Energy Transduction" (R. A. Capaldi, ed.), pp. 279–340. Dekker, New York.
- Olson, J. M., Philipson, K. D., and Sauer, K. (1973). *Biochim. Biophys. Acta* **292**, 206–217.
- Olson, J. M., Giddings, T. H., Jr., and Shaw, E. K. (1976). *Biochim. Biophys. Acta* **449**, 197–208.
- Olson, J. M., Prince, R. C., and Brune, D. C. (1977). *Brookhaven Symp. Biol.* **28**, 238–246.
- Ophir, J., and Ben-Shaul, Y. (1974). *Protoplasma* **80**, 109–127.
- Oren, R., and Gromet-Elhanan, Z. (1979). *Biochim. Biophys. Acta* **548**, 106–118.
- Orlando, J. A., Levine, L., and Kamen, M. D. (1961). *Biochim. Biophys. Acta* **46**, 126–133.
- Owen, P., and Salton, M. R. J. (1977). *J. Bacteriol.* **132**, 974–985.
- Oyewole, S. H., and Holt, S. C. (1976). *Arch. Microbiol.* **107**, 167–182.
- Pailloin, G., Vermeglio, A., and Breton, J. (1979). *Biochim. Biophys. Acta* **545**, 249–264.
- Park, R. B. (1965). In "Plant Biochemistry" (J. Bonner and J. E. Varner, eds.), pp. 124–156. Academic Press, New York.
- Park, R. B., and Biggins, J. (1964). *Science* **144**, 1009–1012.
- Parks, L. C., and Niederman, R. A. (1978). *Biochim. Biophys. Acta* **511**, 70–82.
- Parson, W. W. (1978). In "The Photosynthetic Bacteria" (R. K. Clayton and W. R. Sistrom, eds.), pp. 455–466. Plenum, New York.
- Peters, G. A., and Cellarius, R. A. (1972). *Bioenergetics* **3**, 345–359.
- Petty, K. M., and Dutton, P. L. (1976). *Arch. Biochem. Biophys.* **172**, 335–345.
- Petty, K. M., Jackson, J. B., and Dutton, P. L. (1977). *FEBS Lett.* **84**, 299–303.
- Petty, K. M., Jackson, J. B., and Dutton, P. L. (1979). *Biochim. Biophys. Acta* **546**, 17–42.
- Pfennig, N. (1977). *Annu. Rev. Microbiol.* **31**, 275–290.
- Pfennig, N. (1978). In "The Photosynthetic Bacteria" (R. K. Clayton and W. R. Sistrom, eds.), pp. 3–14. Plenum, New York.
- Pfennig, N., and Trüper, H. G. (1974). In "Bergey's Manual of Determinative Bacteriology" (C. R. E. Buchanan and N. E. Gibbons, eds.), 8th ed., pp. 24–75. Williams & Wilkins, Baltimore, Maryland.
- Pfister, K., and Arntzen, C. J. (1979). *Z. Naturforsch* **34C**, 996–1009.

- Pfister, K., Steinback, K. E., Gardner, G., and Arntzen, C. J. (1981). *Proc. Natl. Acad. Sci. U.S.A.* **78**, 981-985.
- Pick, U., and Racker, E. (1979). *J. Biol. Chem.* **254**, 2793-2799.
- Picorel, R., del Valle-Tascon, S., and Ramirez, J. M. (1977). *Arch. Biochem. Biophys.* **181**, 665-670.
- Pierson, B. K., and Castenholz, R. W. (1978). In "The Photosynthetic Bacteria" (R. K. Clayton and W. R. Sistrom, eds.), pp. 179-194. Plenum, New York.
- Popov, V. J., Kaurov, B. S., Finakov, G. Z., Gulyaev, B. A., Kukarskikh, G. P., Allakhverdov, B. L., and Tageeva, S. V. (1980). *Photosynthetica* **14**, 343-354.
- Prince, R. C., and Crofts, A. R. (1973). *FEBS Lett.* **35**, 213-216.
- Prince, R. C., and Dutton, P. L. (1976). *FEBS Lett.* **65**, 119-177.
- Prince, R. C., and Dutton, P. L. (1977). *Biochim. Biophys. Acta* **462**, 731-747.
- Prince, R. C., and Dutton, P. L. (1978). In "The Photosynthetic Bacteria" (R. K. Clayton and W. R. Sistrom, eds.), pp. 439-450. Plenum, New York.
- Prince, R. C., and Olson, J. M. (1976). *Biochim. Biophys. Acta* **423**, 357-362.
- Prince, R. C., Leigh, J. S., Jr., and Dutton, P. L. (1974). *Biochem. Soc. Trans.* **2**, 950-953.
- Prince, R. C., Baccarini-Melandri, A., Hauska, G. A., Melandri, B. A., and Crofts, A. R. (1975). *Biochim. Biophys. Acta* **387**, 212-227.
- Pucheu, N. L., Kerber, N. L., and Garcia, A. F. (1974). *Arch. Microbiol.* **101**, 259-272.
- Pucheu, N. L., Kerber, N. L., and Garcia, A. F. (1976). *Arch. Microbiol.* **109**, 301-305.
- Rafferty, C. N., and Clayton, R. K. (1979). *Biochim. Biophys. Acta* **546**, 189-206.
- Rafferty, C. N., Bolt, J., Sauer, K., and Clayton, R. K. (1979). *Proc. Natl. Acad. Sci. U.S.A.* **76**, 4429-4432.
- Rao, P. V., and Keister, D. L. (1978). *Biochem. Biophys. Res. Commun.* **84**, 465-473.
- Reed, D. W., and Clayton, R. K. (1968). *Biochem. Biophys. Res. Commun.* **30**, 471-475.
- Reed, D. W., and Mayne, B. C. (1971). *Biochim. Biophys. Acta* **226**, 477-480.
- Reed, D. W., and Raveed, D. (1972). *Biochim. Biophys. Acta* **283**, 79-91.
- Reed, D. W., Raveed, D., and Israel, H. W. (1970). *Biochim. Biophys. Acta* **223**, 281-291.
- Reed, D. W., Raveed, D., and Reporter, M. (1975). *Biochim. Biophys. Acta* **387**, 368-378.
- Remsen, C. C. (1978). In "The Photosynthetic Bacteria" (R. K. Clayton and W. R. Sistrom, eds.), pp. 31-59. Plenum, New York.
- Rivas, E., Reiss-Hussen, F., and le Maire, M. (1980). *Biochemistry* **19**, 2943-2950.
- Romijn, J. C., and Amesz, J. (1977). *Biochim. Biophys. Acta* **461**, 327-338.
- Rubin, B. T., Chow, W. S., and Barber, J. (1981). *Biochim. Biophys. Acta* **634**, 174-190.
- Rutherford, A. W., and Evans, M. C. W. (1979). *FEBS Lett.* **100**, 305-308.
- Rutherford, A. W., and Mullet, J. E. (1981). *Biochim. Biophys. Acta* **635**, 225-235.
- Ryrie, I. J., and Anderson, J. M. (1980). *Eur. J. Biochem.* **107**, 345-354.
- Satoh, K. (1979). *Biochim. Biophys. Acta* **546**, 84-92.
- Sauer, K. (1975). In "Bioenergetics of Photosynthesis" (Govindjee, ed.), pp. 115-181. Academic Press, New York.
- Sauer, K. (1978). *Acc. Chem. Res.* **11**, 257-264.
- Sauer, K. (1979). *Annu. Rev. Phys. Chem.* **30**, 155-178.
- Sauer, K., and Austin, L. A. (1978). *Biochemistry* **17**, 2011-2019.
- Schneider, E., Müller, H.-W., Rittinghaus, K., Thiele, V., Schwulera, U., and Dose, K. (1979). *Eur. J. Biochem.* **97**, 511-517.
- Schwenker, U. A., and Gingras, G. (1973). *Biochem. Biophys. Res. Commun.* **51**, 94-99.
- Schwenker, U. A., St.-Onge, M., and Gingras, G. (1974). *Biochim. Biophys. Acta* **351**, 246-260.
- Schwenn, J. D., and Biere, M. (1979). *FEBS Lett.* **6**, 19-22.

- Scully, M. J., Duniec, J. T., Thorne, S. W., Chow, W. S., and Boardman, N. K. (1980). *Arch. Biochem. Biophys.* **201**, 339-346.
- Shavit, N. (1980). *Annu. Rev. Biochem.* **49**, 111-138.
- Shepherd, W. D., and Kaplan, S. (1978). *J. Bacteriol.* **135**, 656-667.
- Shepherd, W. D., Kaplan, S., and Park, J. T. (1981). *J. Bacteriol.* **147**, 354-362.
- Shimada, K., and Murata, N. (1977). *J. Biochem. (Tokyo)* **82**, 1231-1236.
- Siegel, C. O., Jordan, A. E., and Miller, K. R. (1981). *J. Cell Biol.* **91**, 113-125.
- Simpson, D. J. (1979). *Carlsberg Res. Commun.* **44**, 305-336.
- Simpson, D. J., Høyer-Hansen, G., Chua, N.-H., and von Wettstein, D. (1978). In "Photosynthesis '77" (D. O. Hall, J. Coombs, and T. W. Goodwin, eds.), pp. 537-548. Biochem. Soc., London.
- Singer, S. J. (1971). In "Structure and Function of Biological Membranes" (L. I. Rothfield, ed.), pp. 146-222. Academic Press, New York.
- Singer, S. J., and Nicolson, G. L. (1972). *Science* **175**, 720-731.
- Snozzi, M., and Bachofen, R. (1979). *Biochim. Biophys. Acta* **546**, 236-247.
- Soe, G., Nishi, N., Kakuno, T., and Yamashita, J. (1978). *J. Biochem. (Tokyo)* **84**, 805-814.
- Staehelin, L. A. (1976). *J. Cell Biol.* **71**, 136-158.
- Staehelin, L. A., and Arntzen, C. J. (1979). *Ciba Found. Symp.* [N.S.] **61**, 147-175.
- Staehelin, L. A., Armond, P. A., and Miller, K. R. (1977). *Brookhaven Symp. Biol.* **28**, 278-315.
- Staehelin, L. A., Golecki, J. R., and Drews, G. (1980). *Biochim. Biophys. Acta* **589**, 30-45.
- Stanier, R. Y., and Cohen-Bazire, G. (1977). *Annu. Rev. Microbiol.* **31**, 225-274.
- Steinback, K. E. (1980). In "The Biochemistry of Plants" (A. Marcus, ed.), Vol. 6, pp. 303-319. Academic Press, New York.
- Steinback, K. E., Burke, J. J., Mullet, J. E., and Arntzen, C. J. (1978). In "Chloroplast Development" (G. Akoyunoglou and J. H. Argyroudi-Akoyunoglou, eds.), Vol. 2, pp. 389-401. Elsevier/North-Holland Biomedical Press, Amsterdam.
- Steinback, K. E., Burke, J. J., and Arntzen, C. J. (1979). *Arch. Biochem. Biophys.* **195**, 546-557.
- Steinback, K. E., McIntosh, L., Bogorad, L., and Arntzen, C. J. (1981). *Plant Physiol.* **67**, Suppl., 64.
- Stoeckenius, W., Lozier, R. H., and Bogomolni R. A. (1979). *Biochim. Biophys. Acta* **505**, 215-278.
- Straley, S. C., Parson, W. W., Mauzerall, D. C., and Clayton, R. C. (1973). *Biochim. Biophys. Acta* **305**, 597-609.
- Swarthoff, T., and Amesz, J. (1979). *Biochim. Biophys. Acta* **548**, 427-432.
- Sybesma, C., and Olson, J. M. (1963). *Proc. Natl. Acad. Sci. U.S.A.* **49**, 248-253.
- Takacs, B. J., and Holt, S. C. (1971a). *Biochim. Biophys. Acta* **233**, 258-277.
- Takacs, B. J., and Holt, S. C. (1971b). *Biochim. Biophys. Acta* **233**, 278-295.
- Takamiya, K.-I., and Dutton, P. L. (1979). *Biochim. Biophys. Acta* **546**, 1-16.
- Takemoto, J., and Bachman, R. C. (1979). *Arch. Biochem. Biophys.* **195**, 526-534.
- Thornber, J. P. (1970). *Biochemistry* **9**, 2688-2698.
- Thornber, J. P. (1975). *Annu. Rev. Plant Physiol.* **26**, 127-158.
- Thornber, J. P., Olson, J. M., Williams, D. M., and Clayton, M. L. (1969). *Biochim. Biophys. Acta* **172**, 351-354.
- Thornber, J. P., Dutton, P. L., Fajer, J., Forman, A., Holten, D., Olson, J. M., Parson, W. W., Prince, R. C., Tiede, D. M., and Windsor, M. W. (1978a). In "Photosynthesis '77" (D. O. Hall, J. Coombs, and T. W. Goodwin, eds.), pp. 55-70. Biochem. Soc., London.

- Thornber, J. P., Trosper, T. L., and Strouse, C. E. (1978b). In "The Photosynthetic Bacteria" (R. K. Clayton and W. R. Sistrom, eds.), pp. 133–155. Plenum, New York.
- Tiede, D. M., Leigh, J. S., and Dutton, P. L. (1978). *Biochim. Biophys. Acta* **503**, 524–544.
- Tonn, S. J., Gogel, G. E., and Loach, P. A. (1977). *Biochemistry* **16**, 877–885.
- Trebst, A. (1974). *Annu. Rev. Plant Physiol.* **25**, 423–458.
- Trebst, A. (1980). In "Methods in Enzymology" (A. San Pietro, ed.), Vol. 69, pp. 675–715. Academic Press, New York.
- Trosper, T. L., Benson, D. L., and Thornber, J. P. (1977). *Biochim. Biophys. Acta* **460**, 318–330.
- Trüper, H. G., and Peck, H. D., Jr. (1970). *Arch. Microbiol.* **73**, 125–142.
- Trüper, H. G., and Pfennig, N. (1978). In "The Photosynthetic Bacteria" (R. K. Clayton and W. R. Sistrom, eds.), pp. 19–26. Plenum, New York.
- Vacek, K., Wong, D., and Govindjee (1977). *Photochem. Photobiol.* **26**, 269–276.
- Vadeboncoeur, C., Noël, H., Poirier, L., Cloutier, Y., and Gingras, G. (1979a). *Biochemistry* **18**, 4301–4308.
- Vadeboncoeur, C., Mamet-Bratley, M., and Gingras, G. (1979b). *Biochemistry* **18**, 4308–4314.
- van der Rest, M., and Gingras, G. (1974). *J. Biol. Chem.* **249**, 6446–6453.
- van der Rest, M., Noël, H., and Gingras, G. (1974). *Arch. Biochem. Biophys.* **164**, 285–292.
- Vermaas, W. F. J., and Govindjee (1981). *Photochem. Photobiol.* **34**, 775–793.
- Vermeiglio, A. (1977). *Biochim. Biophys. Acta* **459**, 516–524.
- Vernon, L. P., Ke, B., Katoh, S., San Pietro, A., and Shaw, E. R. (1966). *Brookhaven Symp. Biol.* **19**, 102–126.
- von Jagow, G., and Sebald, W. (1980). *Annu. Rev. Biochem.* **49**, 281–314.
- von Wettstein, D., Møller, B. L., Høyer-Hansen, G., and Simpson, D. (1982). In "On the Origins of Chloroplasts" (J. A. Schiff and H. Lyman, eds.), pp. 243–255. Am. Elsevier, New York.
- Wakim, B., Golecki, J. R., and Oelze, J. (1978). *FEMS Lett.* **4**, 199–201.
- Weiss, R. L. (1976). *J. Bacteriol.* **128**, 668–670.
- Wessels, J. S. C., and Voorn, G. (1972). *Photosynth., Two Centuries Its Discovery Joseph Priestly, Proc. Int. Congr. Photosynth. Res., 2nd, 1971* **2**, pp. 833–851.
- Whitten, W. B., Pearlstein, R. M., and Olson, J. M. (1979). *Photochem. Photobiol.* **29**, 823–828.
- Williams, W. P. (1977). In "Primary Processes in Photosynthesis" (J. Barber, ed.), Vol. 2, pp. 99–147. Elsevier/North-Holland, Amsterdam.
- Woese, C. R. (1979). *J. Mol. Evol.* **13**, 95–101.
- Woese, C. R., Gibson, J., and Fox, G. E. (1980). *Nature (London)* **283**, 212–214.
- Wollman, F. A., and Diner, B. A. (1980). *Arch. Biochem. Biophys.* **201**, 646–659.
- Wollman, F. A., Olive, J., Bennoun, P., and Recouvreur, M. (1980). *J. Cell Biol.* **87**, 728–735.
- Wong, D. (1979). Ph.D. Thesis in Biophysics, University of Illinois at Urbana-Champaign.
- Wong, D., and Govindjee (1981). *Photochem. Photobiol.* **33**, 103–108.
- Wong, D., Merkelo, H., and Govindjee (1981). *Photochem. Photobiol.* **33**, 97–101.
- Wraight, C. A. (1977). *Biochim. Biophys. Acta* **459**, 525–531.
- Wraight, C. A., Lueking, D. R., Fraley, R. T., and Kaplan, S. (1978). *J. Biol. Chem.* **253**, 465–471.
- Yen, G. S. L., Wraight, C. A., and Kaplan, S. (1982). *Biochim. Biophys. Acta* **688**, 605–621.
- Yoch, D. C., Carithers, R. P., and Arnon, D. I. (1977). *J. Biol. Chem.* **252**, 7453–7460.
- Yoshida, M., Sone, N., Hirata, H., and Kagawa, Y. (1977). *J. Biol. Chem.* **252**, 3480–3485.
- Younis, H. M., and Winget, C. D. (1977). *Biochem. Biophys. Res. Commun.* **77**, 168–174.

- Yu, C. A., and Yu, L. (1980). *Biochem. Biophys. Res. Commun.* **97**, 286–292.
- Zankel, K. L. (1978). In "The Photosynthetic Bacteria" (R. K. Clayton and W. R. Sistrom, eds.), pp. 341–346. Plenum, New York.
- Zankel, K. L., and Kok, B. (1972). In "Methods in Enzymology" (A. San Pietro, ed.), Vol. 24, pp. 218–238. Academic Press, New York.
- Zielinski, R., and Price, C. N. (1980). *J. Cell Biol.* **85**, 435–445.
- Zürcher, H., Snozzi, M., Hanselmann, K., and Bachofen, R. (1977). *Biochim. Biophys. Acta* **460**, 273–279.

Orientation of Photosynthetic Pigments in Vivo

JACQUES BRETON
ANDRÉ VERMEGLIO

I. Introduction.....	154
II. Methodology.....	157
A. General Approach.....	157
B. Techniques of Orientation.....	157
C. Interaction of an Electromagnetic Wave with Electronic, Vibrational, or Spin Transitions in an Oriented Sample.....	158
D. Spectroscopy of the Photosynthetic Components.....	164
III. Relative Orientation of Pigments within Isolated Photosynthetic Complexes.....	166
A. Isolated Reaction Centers.....	167
B. Isolated Antenna Complexes.....	174
IV. Orientation of Pigments with Respect to the Membrane Plane.....	178
A. Antenna Pigments.....	178
B. Reaction Centers.....	181
C. Other Constituents.....	185
V. Local Order between Complexes in Photosynthetic Membranes.....	187
VI. Conclusions.....	188
References.....	190

ABBREVIATIONS

A	Absorption
B890,B800-B850	Light-harvesting complexes in bacterial photosynthesis
BChl	Bacteriochlorophyll
Bph	Bacteriopheophytin
Car	Carotenoid
CD	Circular dichroism
Chl	Chlorophyll
<i>Chr</i>	<i>Chromatium</i>
CPI-P700	Chlorophyll <i>a</i> complex of PSI
CPII	Light-harvesting chlorophyll <i>a-b</i> complex
Cyt	Cytochrome
ESR	Electron spin (paramagnetic) resonance
FP	Fluorescence polarization
<i>I</i>	Intermediary acceptor in bacterial photosynthesis
IR	Infrared

LD	Linear dichroism
LHC	Light-harvesting complex
MCD	Magnetic circular dichroism
<i>P</i>	<i>Prosthecochloris</i>
P680	Primary donor of PSII
P700	Primary donor of PSI
PSI	Photosystem I
PSII	Photosystem II
Q_x, Q_y	Electronic transition moments
RC	Reaction center
<i>Rp.</i>	<i>Rhodospseudomonas</i>
<i>Rs.</i>	<i>Rhodospirillum</i>
SP, P870, P960	Special pair, primary donor in bacterial photosynthesis
X, A _{1,2}	Intermediary acceptor of PSI detected by ESR

ABSTRACT

During the past decade, spectroscopy with linearly polarized light has been extensively used to probe the organization of pigments and of electron transfer components in the photosynthetic membrane. This organization can be recognized at different levels.

First, the relative orientation between pairs of transition moments of molecules (pigments and electron transfer components) within an isolated pigment-protein complex can be investigated. As compared to systems derived from green plants, our knowledge is much more advanced in the case of photosynthetic bacteria for which purified complexes containing a small number of chromophores in their native form have been isolated. Various intrinsic limitations (overlap of absorption bands, unknown nature of the interactions between the chromophores, and complex character of the absorption changes) lead, however, to a situation where this organization can be described only in qualitative terms.

Second, an orientation of the transition moments of the various pigments and electron transfer components with respect to the plane of the photosynthetic membrane has been described. Precise values of these angles can be obtained only when the degree of orientation of the membranes themselves is known. A similarity in the organization of the photosynthetic components in green plants and in bacteria is observed.

Finally, the possibility of investigating the mutual orientation of chromophores belonging to adjacent complexes in the photosynthetic membrane is discussed. We also describe how the concomitant analysis of these different levels of order together with distance parameters derived from other measurements can lead to a more precise model of the photosynthetic apparatus.

I. Introduction

Photosynthesis is the overall process by which the electromagnetic energy of light is converted into chemical free energy. The earliest steps of this complex conversion involve the absorption of a photon by the light-harvesting (antenna) pigments, the migration of the excitonic en-

ergy among other antenna pigments until it is trapped by the specialized reaction center (RC). A charge separation then occurs at the level of the RC and the transport of electrons and protons is initiated.

For all known photosynthetic organisms, these processes occur at the level of a membrane, which, like other biological membranes, is mainly built out of hydrophobic proteins partly or entirely embedded in a bilayer of lipids. In addition, it contains a variety of pigments and electron carriers that are mostly noncovalently attached to the proteins. In the course of evolution, the best adapted components have been selected to accomplish each elementary step: (bacterio)chlorophyll (Chl or BChl) and carotenoid (Car) molecules for the capture of light energy and its funneling towards the RC, cytochromes (Cyt), iron-sulfur (Fe-S) proteins, and quinones to carry charges and protons. The high efficiency of the conversion of solar energy by plants and certain bacteria is furthermore due to the precise organization of these components into the photosynthetic membranes. Actually, the photosynthetic membrane, with its system of closed vesicles limited by a thin bilayer of ordered lipids in which are anchored pebbles of Chl-protein complexes, bears some resemblance to both a liquid crystal and a solid-state device. In these integrated structures, fast reactions can take place without the rate-limiting step of the diffusion of the reactants usually encountered in solutions. The selective permeability of these membranes allows the stabilization of the separated charges, the compartmentation of the chemical species, and the storage of free energy under the form of electric potential or of protons gradient.

The notion of structure and organization appears at two different levels. In the pigment-protein complexes, the distances and relative orientations of the chromophores are intrinsic features that prevent wasteful quenching processes (light-harvesting (LH) complexes) and back reactions of the separated charges (RC complexes). In the highly anisotropic membrane itself, the localization of the various complexes, the distances between them, and their relative orientations are of prime importance for the transfer of energy, electrons, and protons.

A complete description and understanding of the process of photosynthesis necessitates not only the determination of the nature and the function of each individual component and the kinetics and thermodynamics of their reactions, but also the knowledge of their localization, positioning, and relative orientation. In general, a chemical approach in elucidating the architecture of biological membranes at the molecular level is rendered difficult because of the heterogeneity of the constituents and of the weakness of the chemical bonding (hydrophobic

interactions, hydrogen bonds, etc.) between them. Therefore, different physical techniques related to several forms of spectroscopy have been extensively used for the analysis of the structure of biological membranes. For example electron microscopy (Staehelin *et al.*, 1977), X-rays (Sadler *et al.*, 1973), and neutron scattering (D. Sadler and D. Worcester, personal communication) have been performed on photosynthetic membranes to obtain a gross view of the structure. The molecular organization is more difficult to analyze, although photosynthetic membranes offer a special case in the sense that a large number of components directly involved in the photosynthetic process, such as Chls, Cars, RC pigments, Cys, and quinones, present characteristic electronic absorption spectra and/or ESR signals and can thus be used as intrinsic probes of the system. Absorption, fluorescence, flash spectroscopy, circular dichroism (CD), resonance Raman, as well as ESR techniques, have been widely used to determine the identity and concentration of the species present, their photochemical activity, and the interactions between them.

In Saclay, France, as well as in several other laboratories, different forms of spectroscopy involving plane-polarized light have been used on anisotropic samples to obtain information on the orientation of the chromophores in photosynthetic membranes and in systems derived from them. The purpose of this chapter is to critically discuss the structural information obtained by these techniques or by related approaches. Although a comprehensive review of the orientation of photosynthetic chromophores has not yet been published, several aspects of this subject have been partly covered in the following references: Hofrichter and Eaton (1976), Gregory (1977), Dutton *et al.*, (1979), Thornber and Barber (1979), Clayton (1980), and Hoff (1982).

In photosynthetic systems, different types of order can be outlined. The first type of order refers to the relative orientation between pairs of transitions belonging to distinct molecules in the same pigment-protein complex. The second type is related to the orientation of the transition moments of the various species (antenna pigments, RC chromophores, electron carriers, proteins) with respect to the membrane plane. Finally, a third degree of order is expected. It is called *local order* as it represents the mutual orientation of the chromophores in adjacent complexes (either of identical or different types). This last type of order represents a challenging area of research for which photosynthetic membranes, because of the unique property of extensive energy transfer among complexes, appear very promising. These three different types of order will be discussed in sequence in the following sections after the methodology underlying these determinations is described.

II. Methodology

A. General Approach

The determination of the orientation of some probes in a sample requires the use of a physical technique sensitive to the anisotropy of that probe and a sample that is oriented. The most straightforward technique is the X-ray crystallography. With photosynthetic material *in vivo* this has only been achieved so far for a BChl-protein complex (water soluble) isolated from *P. aestuarii* in which the BChl *a* molecules are very precisely positioned (2.8 Å resolution) with respect to the protein backbone (Matthews *et al.*, 1979). This technique however cannot be applied to the usual hydrophobic complexes, since they have not been crystallized. To circumvent this problem, the study of the orientation of different intrinsic probes has been performed on oriented particles or photosynthetic membranes by detecting their absorption, emission, or ESR anisotropic properties.

B. Techniques of Orientation

When the object to be investigated is optically resolvable, polarized spectroscopy (absorption or emission) can be performed on an immobile particle by using a microspectrophotometer. However, the lack of collimation in high resolution microscopes is an important source of potential errors (Hofrichter and Eaton, 1976). The objects must be oriented in a macroscopic array to overcome this problem or when they are too small to be seen in a microscope. This is achieved by using one of the following anisotropic properties of the object:

1. *Shape anisotropy.* A shear field can be applied to nonspherical (or deformable) particles. Flowing chloroplasts or bacteria in a narrow channel (Morita and Miyazaki, 1971; Breton *et al.*, 1973a) or in a special cylindrical cell (Sauer, 1965; Tjerneld *et al.*, 1977), and spreading intact chloroplasts, membranes, or particles with a small paint-brush (Breton and Roux, 1971; Penna *et al.*, 1975) will induce some orientation of the object. It is also possible to incorporate the particles in a plastic film (Rafferty and Clayton, 1978; Bolt and Sauer, 1979; Vermeglio *et al.*, 1980) and to stretch the film or to squeeze a polyacrylamide gel (Abdourakhmanov *et al.*, 1979). Another very straightforward and efficient way of orienting membranes is by air-drying a suspension on a flat surface (Morita and Miyazaki, 1971; Breton and Roux, 1971). Orientation of Chls (planar molecules) in liquid crystals has been reported (Journeaux and Viovy, 1978).

2. *Chemical anisotropy*. This has been used to orient isolated Chl either in collodion films (Breton *et al.*, 1972a), in lipids (Cherry *et al.*, 1972; Hoff, 1974), or in monolayers (Sperling and Ke, 1966; Breton *et al.*, 1972b).

3. *Magnetic anisotropy*. This elegant technique was first applied by Geacintov *et al.* (1972a) to chloroplasts and by Breton (1974) to photosynthetic bacteria. The membranes orient themselves so that their larger cross sections are perpendicular to the applied field direction. Details on the mechanisms and causes of the orientation of biological membranes in magnetic fields have been discussed (Hong *et al.*, 1971; Geacintov *et al.*, 1972b, 1974; Breton, 1974; Knox and Davidovich, 1978).

4. *Electric anisotropy*. This has been used on chloroplast fragments or chromatophores (Sauer and Calvin, 1962; Gagliano *et al.*, 1977) and also on isolated (bacterio)Chl-protein complexes (Whitten *et al.*, 1978; Gagliano *et al.*, 1979). Permanent and/or induced dipole moments are involved in this orientation process.

5. *Anisotropy of electronic absorption*. This interesting technique (photoselection) can be used on isolated molecules, complexes, or membranes. In this case the vectorial property of a polarized excitation beam is used to prepare an oriented sample. This technique will be described in more detail in a later section.

C. Interaction of an Electromagnetic Wave with Electronic, Vibrational, or Spin Transitions in an Oriented Sample

1. CASE OF PERFECT ORIENTATION

We will specifically examine the electronic absorption and then generalize for the other interactions. Electronic transitions usually correspond to changes in the distribution of the π -electron clouds in the molecules. For a fully allowed intense transition, this redistribution occurs in well-defined directions in the molecular framework along which the transition is said to be polarized. The geometric formula relating the anisotropic absorption of a molecule to the anisotropic absorption of a collection of these molecules fixed in crystals of different symmetry have been treated by Hofrichter and Eaton (1976). The usual case found for the orientation of the pigments *in vivo* is the case of uniaxial orientation. We will consider as an example an anisotropic particle containing one chromophore characterized by a single transition moment, which makes an angle θ with the long axis of the particle. We will further assume that all

the particles are mechanically aligned with their long axis parallel to the direction X of the mechanical force (Fig. 1). The absorption of the sample for light propagating perpendicular to X and polarized either parallel (A_{\parallel}) or perpendicular (A_{\perp}) to the direction X will be respectively:

$$A_{\parallel} = 3 A \cos^2 \theta; \quad A_{\perp} = \frac{3}{2} A \sin^2 \theta,$$

where A represents the absorption of the same ensemble of transition dipole moments randomly distributed in solution. The linear dichroism (LD), defined as $A_{\parallel} - A_{\perp}$, is then:

$$\text{LD} = 3 A \frac{3 \cos^2 \theta - 1}{2} \quad (1)$$

If a single transition is involved, the LD spectrum will have the same shape as the absorption spectrum but its intensity and sign will be modulated by the function $S = (3\cos^2\theta - 1)/2$. The dependence of S as a function of θ is represented in Fig. 2. Note that for values of S close to either 1 or -0.5 , the shape of the curve is such that a small imprecision in S will lead to a large uncertainty for θ ; an opposite effect is observed when S is close to 0 ($\theta \sim 55^\circ$). Other related expressions which can be found in the literature are the dichroic ratio $D = A_{\parallel}/A_{\perp} = \frac{1}{2} \cot^2 \theta$ and the reduced dichroism LD/A . For other cases of orientation (flow or spreading, magnetic field, air-drying), formula analogous to Eq. (1) have been derived (Breton *et al.*, 1973a). All these calculations can be generalized to circularly degenerated transitions by considering the normal to the plane in which these transitions are located.

In the case of fluorescence, the electric vector of the emitted light has the same direction as the emission transition dipole moment of the molecule. It is thus possible to measure the orientation of an emitting dipole

FIG. 1. Schematic representation of the measurement of LD ($A_{\parallel} - A_{\perp}$) on particles oriented along the axis X . Each particle contains one chromophore whose transition moment (represented by the arrow) makes an angle θ with the direction X .

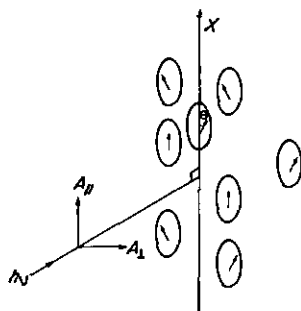

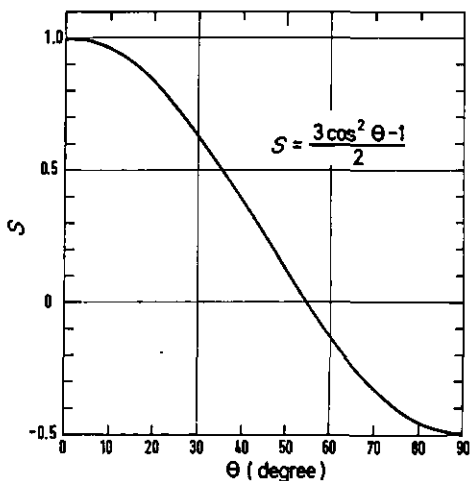

FIG. 2. Dependence of the quantity $S = (3 \cos^2 \theta - 1)/2 = (A_{\parallel} - A_{\perp})/3A$ on the angle θ between the direction of the transition moment and the orientation axis

by exciting with unpolarized light an oriented array of chromophores and monitoring the dichroism of the fluorescence (bifluorescence) with a polarizer. Under similar conditions the dichroism of some light-induced absorbance changes can be measured.

The interaction of light with an electronic transition dipole moment is only one form of a more general interaction of an electromagnetic wave with matter. When IR radiation interacts with molecules, the bonds between the atoms can undergo quantized transitions between several vibrational and rotational modes. If polarized IR light is used on oriented samples (IR dichroism), it is possible to monitor the orientation of some well-defined directions in the molecular framework.

Transitions between the different spin states of unpaired electrons can occur when microwaves are used to excite a sample. In this case, the magnetic vector of the radiation is involved in the interaction. For triplet states, it is possible to use optically detected magnetic resonance to monitor the transitions between the different spin sublevels. In ESR techniques, a permanent magnetic field is applied (usually parallel to the direction of propagation of the microwaves, although transverse modulation has also been used) in order to split the degenerated sublevels of the unpaired electron. When these anisotropic techniques are applied to an oriented sample, the orientation of paramagnetic probes rigidly bound to the system, and which possess g -tensor anisotropy can be determined.

2. DEGREE OF ORIENTATION

Most of the methods of orientation described earlier usually lead to an incomplete orientation of the sample. Even if a saturation is observed for the values of LD/A when increasing the orienting force, this behavior is not in itself a proof that a complete orientation is achieved, especially with heterogeneous systems. In such cases, it would be necessary to determine the final extent of orientation by another technique. X-rays and neutron scattering (Sadler *et al.*, 1973; D. Sadler and D. Worcester, private communication) are of a great potential use in this respect especially to determine the distribution of orientation of membranes (often called *mosaic spread*).

If the distribution of orientation of the objects is known, then one can calculate the exact θ angle by using Eq. (1). Otherwise uncorrected values of LD/A will lead to θ angles, which are always closer to 55° than the true values.

3. FLUCTUATIONS OF ORIENTATION

Owing to pigment-pigment as well as pigment-protein interactions, it is probable that the different chromophores in a well-defined pigment-protein complex are mutually oriented in a rather specific way (possibly including a complete disorder), and we will accordingly suppose that there is little variation in their relative orientation. In contrast, we do not know at the present time how unique is the orientation of the complexes themselves in the native membrane. This orientation can in principle fluctuate both in the time domain (especially if the membrane is fluid) and in space. Such fluctuations lead to the notion of a distribution of the orientation around an average position. It is worth mentioning that for a hydrophobic protein with polar region(s) protruding out of the bilayer, mostly lateral translation and/or rotation of the protein around the normal to the membrane plane can be thermodynamically expected (no "flip-flop" motion). However rocking motions could slightly change the orientation of the chromophores with respect to the membrane plane. For completely hydrophobic proteins, much larger fluctuations are possible.

When such fluctuations are present a measurement of the LD for a given chromophore will lead, after correction for the mosaic spread of the membranes, to a unique value of the order parameter $S = (3 \cos^2 \theta - 1)/2$. However this order parameter now includes the fluctuation of orientation, and the angle θ , which can be calculated, is only an apparent angle. This appears clearly in the limiting case where $S = 0$ (no LD); if

we deal with a single transition, two interpretations are possible: (1) the transitions are at random; (2) the transitions are perfectly oriented at 55° from the normal. For that reason the value of 55° is often referred to as the "magic" angle. It is only when the values of S are close to either 1 or -0.5 that the LD itself tells that the fluctuations are small.

In some cases the distribution of orientation of the probes can be estimated. ESR has been used for this purpose (Libertini *et al.*, 1969; Friesner *et al.*, 1979a) since paramagnetic species with anisotropic g tensor have resonance frequencies that are dependent upon the orientation of the principal axis with respect to the static magnetic field. With photosynthetic membranes, this information has also been obtained by optical techniques involving the Stark effect on the pigments (Paillotin and Breton, 1977).

4. PHOTOSELECTION

In this elegant technique outlined by Albrecht (1961), an excitation beam of linearly polarized light is used to create an anisotropy in a sample (isolated molecules, complexes, membranes). The sample is usually randomly oriented, but in some cases the objects are macroscopically oriented prior to the photoselection.

a. Photoselection on a Random Suspension of Chromophores. In this case the transition moments will be excited proportionally to the square of the cosine of their angle with respect to the direction of the electric vector of the polarized beam. Accordingly an anisotropy, corresponding to a known distribution of excited molecules, will be induced in the suspension. This anisotropy is probed by means of different physical properties: emission (the well-known polarization of fluorescence), absorption changes (photodichroism), or ESR spectroscopy (magneto-photoselection).

The photoselection techniques can give precise information on the relative angle between the transition implied in the absorption and the one involved in the detection, provided that several conditions are fulfilled. The rotational motion of the object must be much slower than the lifetime of the photoinduced species. (On the other hand, if the reverse condition is true, the rotational relaxation time can be followed.) Intermolecular energy transfer leading to a loss of the "memory" of the polarization of the excited species must be avoided. However this loss is of potential interest in studies of energy transfer and local order. Finally, excitation levels must be kept far below the saturation of the observed phenomenon.

A schematic representation of the usual right angle geometry used in photoselection experiments where fluorescence (I_{\parallel} , I_{\perp}) or absorbance changes (ΔA_{\parallel} , ΔA_{\perp}) are detected after excitation with vertically polarized light is given in Fig. 3a. If α is the angles between the absorbing dipole and the one involved in the emission (or the absorption change), the polarization value p is given by

$$p = \frac{I_{\parallel} - I_{\perp}}{I_{\parallel} + I_{\perp}} \quad \text{or} \quad \frac{\Delta A_{\parallel} - \Delta A_{\perp}}{\Delta A_{\parallel} + \Delta A_{\perp}} = \frac{3 \cos^2 \alpha - 1}{\cos^2 \alpha + 3}$$

The analogous representation for magnetophotoselection is given in Fig. 3b. The ESR spectra have to be compared to calculated spectra in order to estimate the angle α_i between the excited optical transition **A** and each of the three principal magnetic axes of the detected paramagnetic species (D_i).

In photodichroism experiments, a single transition is usually detected and the absorbing dipole can be only positioned on a cone, making an angle α around the detected transition. This usually precludes any determination of the relative angle between two spectrally distinct transitions used for the excitation. However such information can be obtained by photodichroism experiments if two (or more) nonparallel transitions are used for the detection.

Owing to an ambiguity as to the sign of the projection of each optical transition onto the three principal magnetic axes, magnetophotoselection usually gives a set of four possible values for the angle between two

FIG. 3. Schematic representation of photoselection experiments: (a) Polarization of fluorescence and photodichroism: the electric vector of the polarized excitation light is represented by **E**. **A** and **D** represent, respectively, the transition moment of the sensitizing and detected chromophores; (b) Magnetophotoselection: the electric vectors of the polarized excitation light are represented by E_{\perp} and E_{\parallel} which are, respectively, perpendicular and parallel to the permanent magnetic field **H**. **A** represents the optical transition moment of the sensitizing chromophore and D_i the detected ESR transitions.

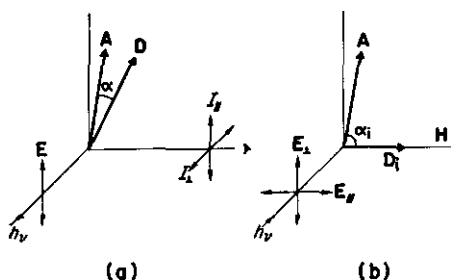

different transition moments used for the excitation (not including the complementary angles). Apart from this indetermination, the orientation of a given transition moment is fully determined with respect to the three magnetic axes. Consequently, it appears that the degrees of determination and of ambiguity are different in optical photoselection and in magnetophotoselection.

b. Photoselection of an Oriented Suspension of Objects. When the angle between the absorption and detected dipoles in the object is known, photoselection experiments can provide information on the distribution of the orientation of the pigments in the anisotropic system. This is due to the fact that the optical anisotropy is used twice, i.e., in the absorption and in the emission (or absorbance change) processes, and that there is a correlation between the two (Nishijima *et al.*, 1966). The distribution of orientation of the membranes of *Rp. viridis* in a magnetic field has been determined by a photodichroism experiment (Paillotin *et al.*, 1979).

D. Spectroscopy of the Photosynthetic Components

In order to relate the spectroscopic measurements described earlier to the orientation of the molecules *in vivo*, one must know the relationship between the studied transition (optical, vibrational, or magnetic) and the framework of the molecule. We will examine here some of the most interesting molecules in photosynthesis.

1. CYTOCHROMES

Because of the fourfold symmetry of the heme of these metalloporphyrins, the α , β , and γ transitions are predicted to be circularly degenerate in the heme plane (the X and Y axes being equivalent). However, imbalance along these two axes can arise from asymmetric potential fields and electrostatic effects of the binding protein (Hofrichter and Eaton, 1976). Such an effect has been demonstrated by MCD, by low temperature absorption spectroscopy (Sutherland and Klein, 1972), and by LD studies on Cyt *c* oriented in a stretched polyvinyl alcohol film (Vermeglio *et al.*, 1980).

ESR studies of a crystal of oxidized Cyt *c* (Mailer and Taylor, 1972) has permitted to relate the three principal axes g_x , g_y , and g_z to the framework of the heme; g_x and g_y are in the plane (along the $N-Fe-N$ directions), whereas g_z is normal to the heme.

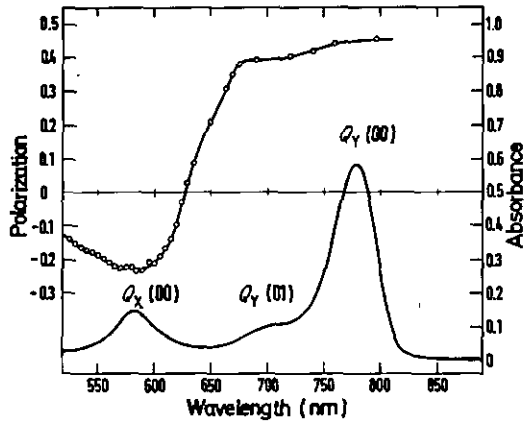

FIG. 4. Absorption (lower part) and fluorescence polarization (upper part) spectra of BChl *a* dissolved in cyclohexanol.

2. CHLOROPHYLLS

These molecules lack the high degree of symmetry of the porphyrins and their absorption bands are therefore associated with different directions in the molecular plane. The S_0 (ground) \rightarrow S_1 (first excited state) lowest energy transition named Q_Y has been predicted to lie along the *Y* molecular axis, which joins the nitrogen atoms of pyrrol I and III (Gouterman, 1961). This is consistent with the high polarization of the fluorescence observed for this transition, in the case of BChl *a* (Fig. 4), Chl *a* (Fig. 5), and Chl *b* ($p = +.42$). The second $S_0 \rightarrow S_2$ electronic transition, named Q_X , is expected to occur in the visible spectral range. This transition is clearly seen in the case of BChl *a* (~ 580 nm) and of

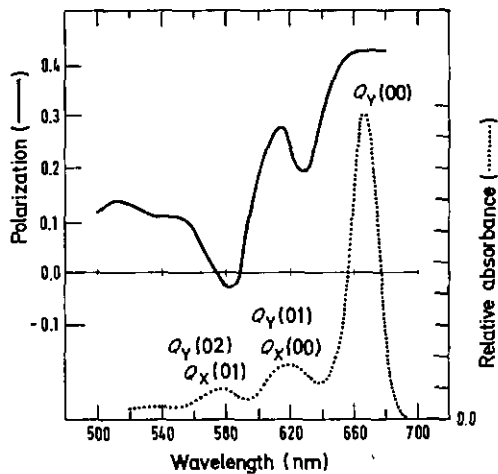

FIG. 5. Absorption (lower part) and fluorescence polarization (upper part) spectra of Chl *a* dissolved in castor oil. (Adapted with permission from Van Metter, 1977a.)

Bph *a* (~ 530 nm), and the p values of $-.23$ and $-.21$, respectively, indicate that these transitions are predominantly, although not entirely, directed along the *X* direction (perpendicular to *Y*). In the case of Chl *a* and *b*, the Q_x transition is very weak and not clearly resolved from vibrational components of the Q_y transition. For Chl *a*, a possible decomposition is indicated in Fig. 5. This decomposition is also consistent with the LD results of Chl *a* in stretched plastic film (Breton *et al.*, 1972a). Furthermore, recent calculations (Petke *et al.*, 1979) seem to indicate that the direction of the $S_0 \rightarrow S_2$ transition of Chl *a* is closer to the *Y* direction than to the *X* direction. Accordingly, the interpretation of the data obtained by polarized light spectroscopy will be more conclusive for photosynthetic bacteria than for green plants. The Soret region of the Chls is composed of a rather complex set of numerous overlapping transitions with various polarizations; from different LD experiments (Breton *et al.*, 1972a; Breton, 1974; Journeaux and Viovy, 1978), the longest wavelength component appears as *X* polarized and then the polarization oscillates between *Y* and *X* toward the shorter wavelengths.

Thurnauer and Norris (1977) applied magnetophotoselection to the triplet state of various monomeric Chls. The magnetic transition with the largest splitting has been assigned to the *z* axis, normal to the molecule plane. They have also shown that for all the Chls the triplet *y* axis is parallel or close ($< 35^\circ$) to the Q_y transition moment.

3. CAROTENOIDS

These molecules present absorption bands in the spectral range 400–500 nm. When they are in all trans configuration, these linear structures containing a large number of π electrons present electronic transitions, which are polarized along the molecular axis (Salem, 1966).

4. PROTEINS

In the UV, the aromatic amino acid residues present transitions polarized in the plane of the cycle. In the IR, the α -helices display characteristic vibrational modes polarized parallel (amide A, 3300 cm^{-1} and amide I, 1650 cm^{-1}) or perpendicular (amide 2, 1550 cm^{-1}) to the axis of the helix (Tsuboi, 1962).

III. Relative Orientation of Pigments within Isolated Photosynthetic Complexes

In vivo, the Chl molecules are generally associated with hydrophobic proteins, and the extraction and purification of these complexes (anten-

na and RC) require the use of detergents. These steps have been easier to achieve in photosynthetic bacteria than with higher plants or algae because of a greater (but unexplained) resistance to the denaturing effect of the detergents. Light-harvesting and RC complexes stable and apparently intact, as judged from several spectral characteristics or functional activities, have been purified from different photosynthetic bacteria species and chemically characterized. From a variety of green plants, two well-defined complexes have been obtained: a P700 Chl *a* complex (CPI) and a LH Chl *a,b* complex (CPII), whose true significance has been recently questioned (Thorner *et al.*, 1979). The analysis of various optical properties can give information on the structure of the different pigment-protein complexes, but it must be emphasized that the relevance of the proposed structures depends upon the retention of their *in vivo* characteristics.

A. Isolated Reaction Centers

1. PHOTOSYNTHETIC BACTERIA

All the RCs isolated from a variety of species contain four BChl molecules, two of them constituting the dimeric primary donor or special pair (SP), two Bph and one quinone (see Fig. 6 for their attributions in the absorption spectrum). (For details on RCs, see Okamura *et al.*, Chapter 5, this volume.) In some cases, one Car and/or several Cyts are also present. Both LD on oriented RC and photoselection studies have been performed to investigate the relative orientation of these various chromophores. There is good agreement between all the experimental results, and the controversy between the proposed models of RC structure arises mainly from the divergent attributions and interpretations of the RC spectral components and light-induced absorbance changes. In this section, we will summarize the LD results and emphasize those obtained by the more straightforward technique of photoselection, before presenting the controversial models of the structure of RC.

RCs from *Rp. sphaeroides* (R-26) have been oriented by a brush-spreading technique (Penna *et al.*, 1975), by stretching gelatin films (Rafferty and Clayton, 1978, 1979a), by squeezing polyacrylamide gels (Abdourakhmanov *et al.*, 1979), and by 8 kV, 3 msec pulsed electric field (A. Gagliano, A. Vermeglio, and J. Breton, unpublished results). Although the degree of orientation depends much on the technique (it is 100 times greater for stretched films than for the brush-spreading technique), the LD spectra present similar features. Figure 6 shows the polarized spectra of RC oriented in stretched films; large orientation ef-

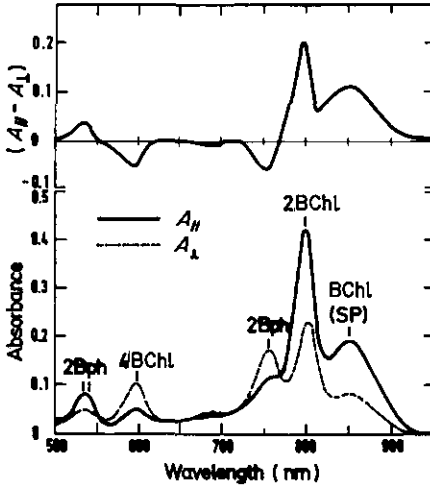

FIG. 6. Polarized absorption (A_{\parallel} and A_{\perp}) (lower part) and LD ($A_{\parallel} - A_{\perp}$) (upper part) spectra of RC from *Rb. sphaeroides* R-26 in stretched gelatin film. For the A_{\parallel} absorption spectrum measurement, the electric vector of the polarized measuring beam was parallel to both the film plane and the stretching direction. For the A_{\perp} measurement, the electric vector was parallel to the film plane and perpendicular to the stretching direction. (Adapted with permission from Rafferty and Clayton, 1979a.) For a "generic" schematic of a RC, see Fig. 2 in Kaplan and Arntzen, Chapter 3, this volume.

facts can be seen for all the transition moments. However, these different orientation techniques generally cannot reveal the mutual orientation between the chromophores, but rather orientation with respect to an unknown direction in the detergent-protein complex. Moreover, the degree of orientation is not known although some decomposition into ideally oriented and unoriented fractions can be made (Rafferty and Clayton, 1979a).

More conclusive results have been obtained by photoselection experiments: Polarization excitation spectra have been measured for both the fluorescence emitted from the 870 nm transition (Ebrey and Clayton, 1969) and the light-induced absorbance change related to this transition (Mar and Gingras, 1976; Shuvalov *et al.*, 1977; Vermeglio *et al.*, 1978) as shown in Fig. 7. A constant polarization value close to the theoretical limit was observed when exciting within the 870 nm band and detecting either the fluorescence ($p = +.5$) (Ebrey and Clayton, 1969) or the absorbance change occurring at 900 nm ($p = +.45, \pm .02$) (Vermeglio *et al.*, 1978; Rafferty and Clayton, 1979b). Previous reports of lower values of p ($p = +.22, +.25$) by Mar and Gingras (1976) and Shuvalov *et al.* (1977) have been shown by Vermeglio *et al.* (1978) to be due to an artifact arising from the saturation of a small fraction of RC with slow back-reactions, and the proper conditions for photoselection were thus strongly altered. After correction of the data of Shuvalov *et al.* (1977) for this artifact, there is good agreement between the polarization excitation spectrum reported by this group and the one by Vermeglio *et al.* (1978).

Several conclusions can be drawn from the spectra shown in Fig. 7. The constant p value ($p = +.45$) observed for the 870-nm band demon-

strates that this transition of the SP is due to either a single transition or to two parallel transitions and therefore constitutes a well-defined direction in the RC complex. A determination of the angle between this direction and a single pure transition is possible only (for *Rp. sphaeroides*, 2:4:1) upon excitation in three spectral regions: (a) 450–500 nm where the Car absorbs; a p value of -0.24 is obtained, leading to an angle of 75° . However, this value cannot be interpreted unambiguously as a (di)cis conformation has been demonstrated for the RC Car (Lutz *et al.*, 1978). (b) and (c) at ~ 530 and 546 nm where the Q_x of the two Bph molecules can be resolved at low temperature (Clayton and Yamamoto, 1976); these give p values of $+0.05$ ($\alpha_{530-870} = 50^\circ$) and -0.06 ($\alpha_{546-870} = 60^\circ$), respectively (Vermeglio *et al.*, 1978). In other spectral regions, where several absorption bands overlap, the p values are only related to the average angle between the different transitions and the 870-nm direction. The average angle between the Q_y transitions of the BChl molecules absorbing at 800-nm and the 870-nm transition is $\sim 30^\circ$, whereas values of $65-70^\circ$ can be calculated for the average angle of either the 4BChl Q_x transitions (around 600 nm) or the Q_y transitions of the two Bph molecules with the 870-nm transition. The preceding angular relationships are direct deductions from simple photoselection experiments and fully compatible with the LD results on mechanically oriented RC (Clayton *et al.*, 1979). Therefore, we believe that all models of the organi-

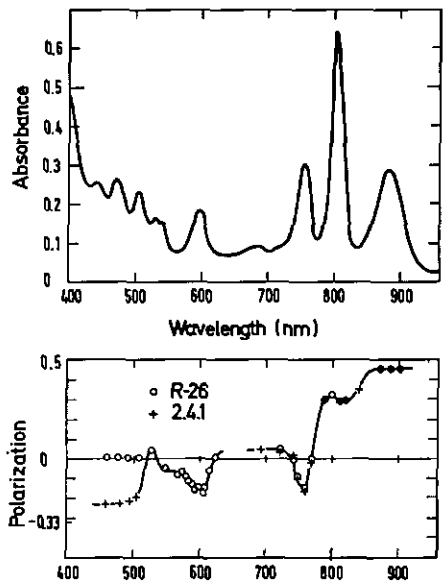

FIG. 7. (Upper part) Absorption spectrum of RC isolated from *Rp. sphaeroides* 2:4:1. (Lower part) Excitation polarization spectrum of the absorbance changes observed at 870 nm for RC from *Rp. sphaeroides* 2:4:1 (+) and R-26 (○). Both spectra were measured at 150° K. (From Vermeglio *et al.*, 1978.)

zation of the chromophores in RC should take into account these experimental results.

Additional information may be obtained upon excitation within a pure absorption band and observation of light-induced absorbance changes at different wavelengths. This is the case, for example; upon excitation within the two spectrally resolved Q_X transitions of the Bph molecules and observation of the shift of their Q_Y transition. From such an experiment, Vermeglio *et al.* (1978) were able to propose a model for the arrangement of the four transitions of the two Bph molecules relative to the 870-nm transition (Fig. 8). Excitation within the 870-nm band and detection of the absorbance changes of P^+ ($P870^+$) in the visible and near IR region has been reported by Shuvalov *et al.* (1977) and Vermeglio *et al.* (1978) and are shown in Fig. 9. After correction for the earlier artifact in the measurements of Shuvalov *et al.* (1977), the experimental results of both groups are in good agreement. However their interpretations of the spectra differed markedly. Shuvalov *et al.* (1977) proposed that the changes occurring around 800 nm upon photo-oxidation of the SP are linked to absorption band shifts of the two BChl molecules absorbing at this wavelength. These two BChl molecules are supposed to be in excitonic interaction because of the similar bandwidth of their respective contribution to the CD spectrum (Reed and Ke, 1973). In an alternative interpretation, Vermeglio *et al.* (1978) decomposed the absorbance changes occurring around 800 nm into an absorption band shift and the bleaching of a small band peaking at 805 nm, perpendicular to the 870-nm direction. This was taken to support the hypothesis of Vermeglio and Clayton (1976) that the 805 and 870-nm bands arise from excitonic coupling of the two BChl molecules of the SP. Both interpretations can explain the ΔCD (light-minus-dark) spectrum and the polarized absorbance changes depicted in Fig. 9.

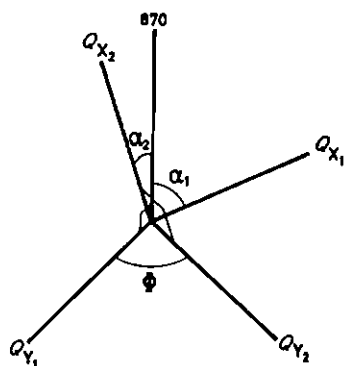

FIG 8. Schematic representation of the arrangement of the transition moments (870 nm, Bph 546 Q_{X1} , Q_{Y1} and Bph 530 Q_{X2} , Q_{Y2}) within a RC. $\alpha_1 = 60^\circ$, $\alpha_2 = 50^\circ$, and $\Phi = 55^\circ$ or 125° . [From Vermeglio *et al.* (1978).]

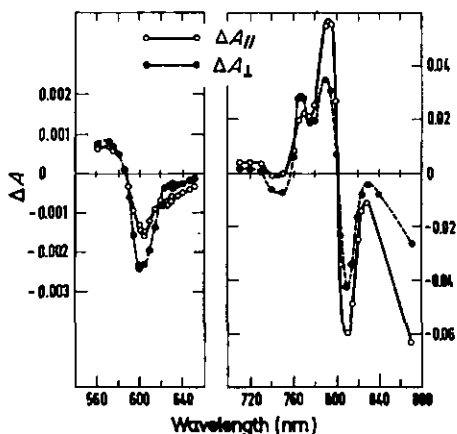

FIG. 9. Difference spectra induced by 900 nm vertically polarized light excitation for both parallel ($\Delta A_{||}$) and perpendicular (ΔA_{\perp}) polarization of the analyzing beam for RC isolated from *Rp. sphaeroides* R-26. [Visible part adapted with permission from Rafferty and Clayton (1979b); infrared part from Vermeglio *et al.* (1978).]

The interpretation of the polarized light-induced changes of the SP is less ambiguous in the Q_x region. Rafferty and Clayton (1979b) have detailed photoselection experiments in that region (Fig. 9) after their discovery of a weak band peaking at 630 nm in the polarized ΔA spectrum related to P^+ of RC in stretched gelatin films (Rafferty and Clayton, 1979a). They attributed the absorption bands peaking at 600 and 630 nm to the two excitonic components of the interacting Q_x transitions of the SP. Their photoselection experiments confirmed this hypothesis since they found an angle of $90^\circ \pm 15^\circ$ between the 600- and 630-nm transitions as predicted by the exciton theory. Further support of that interpretation can be seen in the ΔCD spectrum of oxidized minus reduced RC, which presents a S-shaped signal with maximum and minimum at 600 and 630 nm, respectively (Reed and Ke, 1973).

Frank *et al.* (1979b) and Boxer and Roelofs (1979) performed magnetophotoselection experiments on isolated RC from the mutant *R-26* of *Rp. sphaeroides*. They both agree with the earlier conclusions of Thurnauer and Norris (1976) that the 870-nm transition lies predominantly along one of the principal magnetic axes of the SP triplet state. However some differences, probably reflecting the divergent methods of data interpretation, can be seen in the papers of Frank *et al.* (1979b) and of Boxer and Roelofs (1979). Nevertheless, the data of Frank *et al.* (1979b) are in agreement with the 60° angle found by Vermeglio *et al.* (1978) for the angle between the 550-nm transition (Q_x of Bph) and the 870-nm transition of the SP. The data of Boxer and Roelofs (1979) are in agreement with the observation of Rafferty and Clayton (1979b) of the composite nature of the 600–650 nm absorbing region.

The different interpretations of the light-induced absorption changes

occurring in the 800-nm region proposed by Shuvalov *et al.* (1977) and Vermeiglio *et al.* (1978) lead to completely different pictures of the arrangement of the four BChl molecules in the RC. In Shuvalov's model, the two Q_Y transitions of the BChl molecules of the SP are parallel because their excitonic interaction gives rise to only one allowed transition moment (870 nm). The two transition moments absorbing at 800 nm of the other BChls are nearly parallel (790 nm) and nearly perpendicular (810 nm) to the 870-nm transition. In the alternate model of Vermeiglio *et al.* (1978) and Rafferty and Clayton (1979a, b), the SP presents two distinct excitonic components (870 and 805 nm). From the relative values of the oscillator strength of the excitonic bands, the angle between the transitions of the two monomeric BChl in the SP can be estimated. This angle is $\sim 25^\circ$ between the Q_Y transitions, whereas it is $\sim 40^\circ$ for the Q_X transitions.

At present, it is difficult to make a definite choice between the two proposed models because of the consistency of both interpretations of the polarized ΔA spectra. In that context, photoselection studies on RC isolated from the BChl *b* containing species *Rp. viridis*, which presents a better spectral resolution in the 830-nm band (analogous to the 800-nm band of BChl *a* containing RC), could provide a more clear-cut interpretation of the absorbance changes related to state P^+ . Such photoselection experiments have been reported by Shuvalov and Asadov (1979). The values of $(\Delta A_{\parallel} - \Delta A_{\perp})/(\Delta A_{\parallel} + \Delta A_{\perp})$ for the absorbance changes of P^+ upon excitation at 980 nm are plotted in Fig. 10 as a

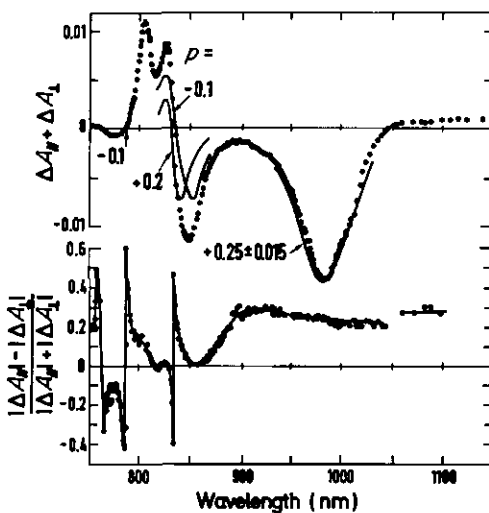

FIG. 10. Photoselection experiments performed on RC from *Rp. viridis* at 100°K. (Upper part) Spectrum of absorbance changes ($\Delta A_{\parallel} + \Delta A_{\perp}$) induced by exciting light at 980 nm, which was polarized either parallel (ΔA_{\parallel}) or perpendicular (ΔA_{\perp}) to the measuring light. The solid curves indicate the resolved components of the difference absorption spectrum with their attributed p values. (Lower part) Spectrum of $p = |\Delta A_{\parallel}| - |\Delta A_{\perp}| / |\Delta A_{\parallel}| + |\Delta A_{\perp}|$. (Adapted with permission from Shuvalov and Asadov, 1979.)

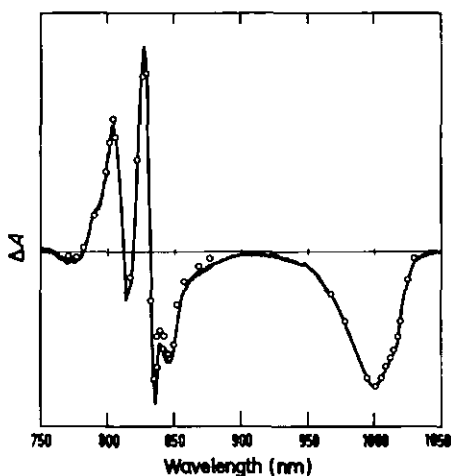

FIG. 11. Difference absorption spectrum measured at 4.2° K for *Rp. viridis* RC recorded with a Cary 17 D spectrophotometer in the dark and during continuous illumination. The dots correspond to laser-induced absorbance changes measured point-by-point.

function of the analyzing wavelength. The low polarization value ($p = +.25$) obtained when exciting and observing within the 980-nm band was assumed by these authors to be due to depolarization by the artifact described earlier. We have repeated similar photoselection experiments under short illumination time conditions and indeed found a higher p value of $+.45$ (A. Vermeglio, G. Paillotin, and J. Breton, unpublished results) consistent with previous results on BChl *a* containing species (Vermeglio *et al.*, 1978; Rafferty and Clayton, 1979b). Our p values at other wavelengths are in good agreement with the ones reported in Fig. 10 after corrections.

The decomposition of the light-induced absorbance changes proposed by Shuvalov and Asadov (1979) is depicted in Fig. 10. The light-induced changes in the 820–880-nm region were attributed to two absorption band shifts in order to explain the sharp changes of the p values in the line of the decomposition proposed by the same authors (Shuvalov *et al.*, 1977) for *Rs. rubrum* species. One does, however, notice that the absorption band shifts are not symmetrical (see Fig. 10). From our photoselection study of *Rp. viridis* RC at 150°K, LD studies of oriented cells (see following section) and very low temperature (4°K) difference spectrum of isolated RC and chromatophores (Fig. 11), we conclude that the light-induced changes of P^+ are best fitted in the 820–880-nm region by the bleaching of a band centered at 850 nm with a negative polarization value and by two symmetrical absorption band shifts around 830 nm. The bleaching at 970 and 850 nm, clearly seen at 4°K for RC from *Rp. viridis* in the state P^+ (Fig. 11), is interpreted as the disappearance of the two excitonic components of the SP.

2. GREEN PLANTS

Up to now highly purified RC has not been isolated from green plants. Particles enriched in P700 are however available. They contain ~ 40 antenna Chl *a* and several Car molecules per P700. The spectroscopic work on these particles is far more complex than for RC isolated from photosynthetic bacteria for the obvious reason that the absorption of the antenna overwhelms the absorption of the RC.

Nevertheless some interesting information on the mutual arrangement of the pigments in the PSI particles of Bengis and Nelson (1975), which contain ~ 40 Chl *a* and ~ 13 Car per P700 has been gathered by Junge and his co-workers (Junge *et al.*, 1977; Junge and Schaffernicht, 1978, 1979) using a photoselection technique. By monitoring the polarization of the absorbance changes at 700 nm upon polarized light excitation in all the absorption bands (including the 700-nm band of the SP) they observed positive dichroic ratios that never exceed 4:3. This observation led them to two alternative possibilities for the structure of the SP: (1) If the photo-oxidized dimer is the only species absorbing at 700 nm, the Q_Y transition moments of the two Chls in the SP are mutually perpendicular; (2) If there are antennae absorbing at this wavelength in addition to the dimer, then the *Y* axis of the antennae is almost perpendicular to the former (Junge *et al.*, 1977). Furthermore, it has been observed that the average directions of both the Car transition moments and the Q_Y transitions of the antenna Chls absorbing above 690 nm lie in the same plane as the 700-nm transition of the SP.

B. Isolated Antenna Complexes

1. PHOTOSYNTHETIC BACTERIA

Thornber *et al.* (1978) proposed that the LH complexes of purple bacteria can be divided in two biochemically distinct categories: a B890 and a B800–B850 complex. (For further details, see Kaplan and Arntzen, Chapter 3, this volume.) The absorption maximum of the B890 complex is located between 850 and 890 nm depending upon the bacterial species. It contains two BChl *a* molecules in excitonic interaction, as shown by the characteristic CD signals in the Q_X and Q_Y absorption regions and one Car (which is missing in the case of the blue–green mutants). The B800–B850 complex contains two BChl *a* analogous to the ones of a B890 complex but absorbing around 850 nm (and in some cases at ~ 820 nm). A third one absorbs maximally at 800 nm and is apparently not in excitonic interaction with the other two. The molecular weight of the basic unit for both complexes is of the order of 20 kD but oligomeric forms have also been observed.

The LD of the B890 and B800–B850 complexes isolated from *Rp. sphaeroides* and oriented in stretched polyvinyl-alcohol films has been investigated by Bolt and Sauer (1979). The dichroic ratio of the B890 complex isolated from the *R-26* mutant varies across the Q_Y absorption region and presents two plateaus ($D = 1.30$ at 835 nm and $D \approx 1.57$ at 885 nm) on each side of the absorption maximum (853 nm). The mid-point of the dichroic ratio versus wavelength curve is located at ~ 860 nm. A similar behavior is observed for the B800–B850 complex (Fig. 12). In the Q_X region the dichroic ratio is constant ($D = 0.43$) for the B890 complex, whereas it varies for the B800–B850 complex ($D = 0.38$ at 610 nm and $D = 0.84$ at 575 nm). In addition, the dichroic ratio is 0.78 for the Car in the B800–B850 complex. Using a curve-fitting procedure on these polarized spectra, the two excitonic components in the Q_Y region of the B890 complex were located at ~ 852 and 867 nm with a ratio of their areas leading to an angle of 78° between the Q_Y transitions of the monomers. For the B800–B850 complex the Q_X region could also be analyzed in terms of a band ($\lambda_{\max} = 593$ nm) representing the two exciton coupled transitions and a band ($\lambda_{\max} = 584$ nm) corresponding to the isolated transition of the monomer-like BChl *a* absorbing at 800 nm (Bolt and Sauer, 1979). The angles between these transitions and the stretching axis were also calculated, but the rather narrow range of these angles (48° – 68°) around the “magic” angle of 55° casts some doubts on their real significance. In the Q_X region very similar results have been obtained by using electric orientation of the complexes (A. Gagliano, A. Vermeglio, and J. Breton, unpublished results), although the dichroic ratios were smaller.

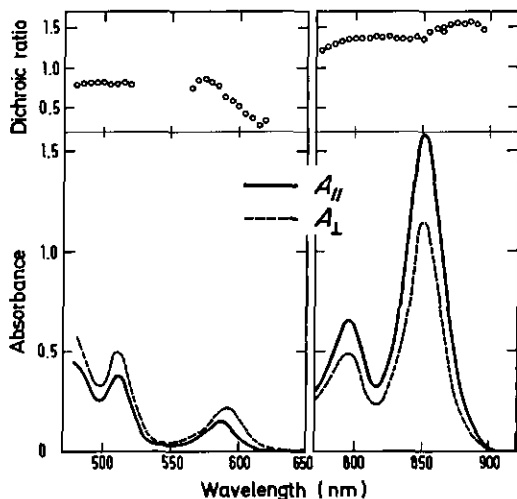

FIG. 12. Polarized absorption spectra measured parallel (—) and perpendicular (---) to the stretch axis for light-harvesting complexes isolated from *Rp. sphaeroides* 2:4:1 embedded in polyvinyl alcohol. The stretching ratio was equal to 2.9. Open circles represent the dichroic ratios ($A_{||}/A_{\perp}$) calculated from the polarized absorption spectra. (Adapted with permission from Bolt and Sauer, 1979.)

The polarization of the fluorescence of these complexes has been investigated by Breton *et al.* (1981). Upon excitation at several wavelengths within the longest wavelength band, a polarization of $+0.13 \pm 0.01$ is observed throughout the fluorescence band. This result can be rationalized by assuming that the two (orthogonal) excitonic components have an equal probability to fluoresce, which causes them to behave like a circularly degenerated oscillator ($p = +0.14$). Upon excitation at 800 nm the B800–B850 complex gives $p = +0.13 \pm 0.01$ showing that the 800-nm transition is parallel to the plane of circular degeneracy of the long wavelength transitions. The fluorescence polarization (excitation) spectra of the two complexes are shown in the Q_x region (Fig. 13). With the B890 complex, a rather constant polarization ($p = -0.17$), close to the limit of -0.23 observed for isolated BChl *a*, shows that the dominant exciton component is almost perpendicular ($\theta \sim 70^\circ$) to the plane of circular degeneracy, implying an almost parallel orientation of the Q_x transitions of the monomers. For the B800–B850 complex a similar behavior is found on the long wavelength side of the Q_x region, whereas the polarization rises significantly ($p = -0.04$) on the short wavelength side of this band. A decomposition of this region into a band representing the two coupled molecules and a band (of one-half amplitude) corresponding to the third BChl *a* indicates that the Q_x direction of this latter molecule is tilted at less than 20° out of the plane of circular degeneracy. Upon

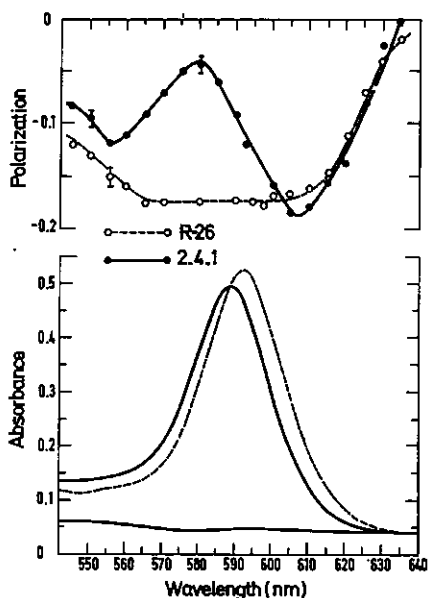

FIG. 13. Absorption (lower part) and fluorescence excitation (upper part) spectra in the Q_x region of light-harvesting complexes isolated from *Rp. sphaeroides* 2:4:1 (—) and R-26 (----) suspended in 2 M sucrose, 0.1% LDAO.

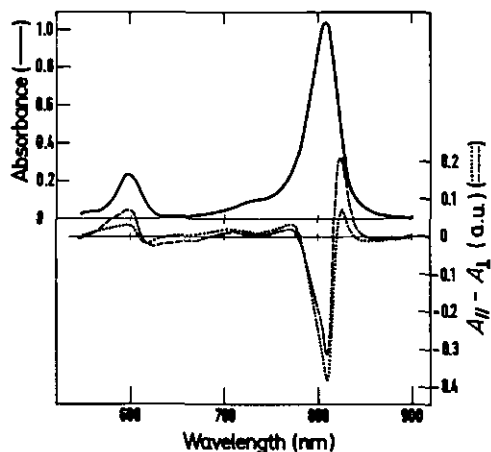

FIG. 14. Absorption (—) and LD of the soluble BChl *a*-protein complex isolated from *P. aestuarii* and oriented with low (---) and high (····) extent of hydration of the films prior to the stretching. The \parallel and \perp subscripts refer to the direction of the stretched axis. Spectra taken at 300°K.

excitation in the Car absorption bands of the B800–B850 complex isolated from *Rp. sphaeroides* (either 2:4:1 or G1C) p values of -0.09 were obtained, indicating that the Car molecule is tilted at $\sim 45^\circ$ out of the plane of circular degeneracy.

The LD of crystals of the BChl *a*-protein complex from *P. aestuarii* has been investigated (Olson *et al.*, 1969; Olson, 1970). The 809-nm transition was found to be oriented at less than 55° of the crystal axis, whereas an opposite orientation was observed at 603 nm. Electric dichroism performed on solutions of this complex (Whitten *et al.*, 1978) has revealed that only one part of the long wavelength absorption band, namely the 813-nm component, exhibits a dichroism. Figure 14 shows two LD spectra obtained with stretched polyvinyl-alcohol films of this complex (J. Breton, unpublished results, 1979). Slightly different orientations were achieved depending upon the extent of hydration of the films prior to the stretching. Several spectral components could be discerned in both the Q_x and the Q_y regions. Lowering the temperature to 100°K confirms this observation but does not resolve additional obvious components. The problem of relating the spectral components to each of the seven molecules of the monomer unit, as seen by X-ray crystallography, is fairly complex especially in view of the excitonic coupling between the BChl *a* molecules.

2. GREEN PLANTS

Van Metter (1977b) reported detailed optical measurements [absorption, CD, fluorescence polarization (FP)] on isolated CPII complexes. The CD spectrum is interpreted in terms of an excitonic interaction for

the three Chl *b* but not for the three Chl *a* molecules. The small value ($p = +.02$) observed for the FP upon excitation at 650 nm is indicative of a nearly spherical symmetry for the Chl *b* exciton states. This suggests a C_3 symmetry for the Chl *b* monomers with an angle of 125° between the symmetry axis and each transition of the exciton states, whereas the angle between the projection of these transitions on the plane of the trimer and the vector from the center of gravity to each monomer is between 0° and 60° . Several possible angles (always $> 50^\circ$) between the transition moments of the Chl *a* can be calculated from the FP data, and a model is proposed in which the three Chl *a* are arranged at the periphery of a core of three *b* (Knox and Van Metter, 1979).

The CPI complex exhibits a rather high FP ($p = +.14$ for 640-nm excitation) as shown by Vacek *et al.* (1977). Upon electric field orientation a LD signal (λ max 686 nm), which is narrower than the Q_Y absorption band (λ max 677 nm) has been observed (Gagliano *et al.*, 1979). From photoselection experiments (Junge *et al.*, 1977; Junge and Schaffernicht, 1978), it has been concluded that the ~ 13 Car molecules are within less than 30° from each other and that their average direction is approximately parallel to the one of the Q_Y transitions of the long wavelength forms of Chl.

IV. Orientation of Pigments with Respect to the Membrane Plane

A. Antenna Pigments

1. GREEN PLANTS

Studies of the dichroism of Chl *in vivo* have been conducted in the past by microspectrophotometry on large chloroplasts (Menke, 1943; Frey-Wyssling and Wuhrmann, 1947; Goedheer, 1955; Ruch, 1957; Butler *et al.*, 1964; Olson *et al.*, 1964). Whenever a dichroism was observed, it was interpreted as arising either from an "artifact" (form dichroism) or from a very small degree of orientation of some long wavelength form of Chl *a*. Similar conclusions were also drawn for mechanically oriented spinach chloroplasts (or chloroplast fragments) by Sauer and Calvin (1962), Sauer (1965), and Thomas *et al.* (1967). A critical review of these early works can be found in Breton (1977b).

The first reports of a significant orientation of Chl *in vivo* came in the early 1970s. Breton and Roux (1971) working with spinach chloroplasts oriented by air-drying or by spreading described their LD spectra in

terms of the orientation of the X and Y directions of several forms of Chl and of the Car molecules. Geacintov *et al.* (1972a), using magnetically oriented *Chlorella*, observed an orientation of the Q_Y transitions of Chl a . Since these early reports a large number of articles dealing with either the LD (Geacintov *et al.*, 1972b, 1974; Becker *et al.*, 1973; Breton *et al.*, 1973a; Faludi-Daniel and Breton, 1975; Demeter *et al.*, 1976; Vermeglio *et al.*, 1976; Gagliano *et al.*, 1977; Tjerneld *et al.*, 1977; Biggins and Svejksky, 1978) or the polarized fluorescence (Geacintov *et al.*, 1972a, b, 1974; Breton *et al.*, 1973b; Breton, 1975; Becker *et al.*, 1976; Garab and Breton, 1976) of oriented chloroplasts have appeared. As an example, Fig. 15 shows the polarized absorption spectra at low temperature for magnetically oriented spinach chloroplasts. Rather than analyzing each of these articles in detail we will summarize here what the present state of knowledge is on the orientation of the antenna pigments in the membrane of green plants.

1. The Chl a molecules absorbing between 680 and 730 nm have their Q_Y transition moments rather close to the membrane plane ($\theta > 65^\circ$).
2. The Chl a molecules absorbing at shorter wavelengths (660–680 nm) have their Q_Y transition moments either making an angle θ close to 55° with the membrane normal or almost at random.
3. The X -polarized transitions of at least part of the Chl a molecules are oriented out of the membrane plane ($30^\circ < \theta < 50^\circ$).
4. The Chl b molecules are oriented in such a way that their Y directions are out of the membrane plane ($\theta < 55^\circ$), whereas their X directions are closer to this plane ($\theta > 55^\circ$).

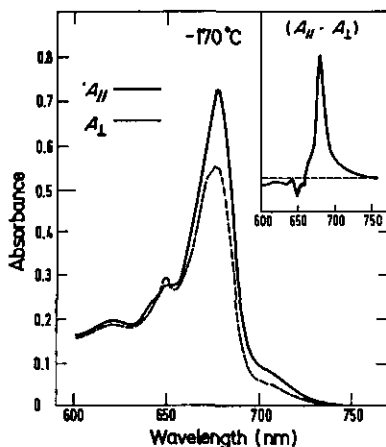

FIG. 15. Absorption spectra of a suspension of oriented chloroplasts measured at -170°C . The measuring beam was polarized either parallel or perpendicular to the chloroplast's membrane plane. The insert represents the LD spectrum ($A_{||} - A_{\perp}$).

5. The transition moments of at least a fraction of the Car molecules are oriented close to the membrane plane ($\theta > 55^\circ$).
6. The emission spectrum of *in vivo* Chl *a* is heterogeneous. The long wavelength emission originates from the pigments oriented the closest to the membrane plane. At least five different emitting species have been detected at low temperature by their different extent of orientation (Garab and Breton, 1976).

Apart from these basic observations one report indicates that divalent cations induce a reorientation of a form of Chl *a* absorbing around 690 nm (Biggins and Svejksky, 1978). However the possibility that the effect observed on the LD spectrum is due to an increase in light scattering is quite probable.

The dichroism of the transient absorbance changes linked to the Stark effect occurring on the antenna pigments when a short flash of light is used to induce a separation of charges across the photosynthetic membrane has been investigated on magnetically oriented spinach chloroplasts (Breton and Mathis, 1974; Breton and Paillotin, 1977). By considering both the absorption and the absorption changes spectra measured in polarized light and with the additional knowledge of the direction of the induced electric field (parallel to the membrane normal), Paillotin and Breton (1977) came to the conclusion that the observed effects were indicative of small fluctuations ($< \pm 5^\circ$) in the orientation of the Chl pigments with respect to the normal. For example, this indicates that the Q_Y transitions of the Chl *a* molecules absorbing in the range 660–680 nm are oriented at about 55° from the normal rather than at random.

2. PHOTOSYNTHETIC BACTERIA

The antenna pigments of photosynthetic bacteria have been found to be specifically oriented in all the species which have been investigated by LD. Orientation has been achieved either with chromatophores by air-drying (Morita and Miyazaki, 1971, 1978; Breton, 1974; Vermeiglio and Clayton, 1976), by electric fields (Gagliano *et al.*, 1977), or with intact cells by using flow (Morita and Miyazaki, 1971) or magnetic fields (Breton, 1974; Clement-Metral, 1975; Paillotin *et al.*, 1979). In all cases, the Q_Y transitions of the BChl *a* (or BChl *b* in the case of *Rp. viridis*) have been found to lie close to the membrane plane ($\theta > 65^\circ$ – 75°), whereas their Q_X transitions are, on the average, almost perpendicular to this plane ($\theta < 30^\circ$). This last observation is reinforced when one considers that the band at ~ 590 nm for isolated BChl *a* is not a pure *X* transition ($p = -.22$). Furthermore, an orientation out of the membrane plane ($\theta \sim$

40°–45°) has been detected for the axis of the Car molecules. For those bacteria that contain B800–B850 antenna in addition to the B890 form, all the Q_Y transitions make approximately the same angle with the membrane plane. However, Vermeglio *et al.* (1979) observed that the LD/A in the Q_X absorbing region (~ 590 nm) was smaller for these bacteria than for the ones lacking the B800–B850 form and concluded that, in contrast to the other BChl *a* molecules, the *X* transitions of the BChl *a* molecules which absorb at 800 nm were oriented close the membrane plane ($\theta > 60^\circ$).

B. Reaction Centers

1. GREEN PLANTS

Junge and Eckhof (1973, 1974) used a photoselection technique on randomly oriented chloroplasts to analyze the orientation of P700. By excitation with polarized light of wavelengths > 680 nm (for which the Q_Y transitions of the antenna Chl *a* are close to the membrane plane), an anisotropic set of excited membranes can be created. A dichroic ratio of 1.15 was observed at both 705 and 430 nm. The quantitative interpretation of these data necessitates additional information on the arrangement of the antenna Chl *a* around the P700. Assuming a circular degeneracy, which is substantiated by several experiments (Junge, 1975; Vacek *et al.*, 1977), it can be concluded that both the 705- and the 430-nm transition moments of P700 make an angle of less than 25° with the plane of the membrane. The conclusion that the whole P700 dimer is oriented approximately parallel to the membrane plane (Junge, 1975; Junge and Schaffernicht, 1978) would however require a further hypothesis concerning the *X* polarization of the 430-nm transition, which remains to be shown for a dimer of Chl *a*.

A more straightforward determination of the orientation of P700 was obtained by measuring the dichroic ratio of the absorbance changes on magnetically oriented chloroplasts (Breton *et al.*, 1975; Vermeglio *et al.*, 1976; Breton, 1977a). Large dichroic ratios ($D > 2.3$) were measured at 700, 685, and 820 nm, whereas a value lower than 1 ($D < 0.4$) was observed around 660 nm. Without any hypothesis on the arrangement of the antenna, these results indicate that the 700-nm transition is tilted at less than 20° from the membrane. A tilt angle of 50° with the membrane was found for the transition at 660 nm, which was ascribed to an excitonic component of either the Q_Y or Q_X transitions in the SP. This has been presented (Breton, 1977a) as an evidence that the two Chl rings in the SP cannot be both parallel to the membrane plane in contrast with

the model of Junge (1975). In order to resolve this discrepancy, an unambiguous interpretation of the absorbance changes linked to the photo-oxidation of P700 in terms of the bleaching of the dimer, of the apparition of a monomer-like absorption, of spectral shifts of the neighbor pigments, and of the excitonic components of the dimer is first required.

There is only one report on the orientation of PSII reaction center (P680) by Mathis *et al.* (1976). These authors measured the linear dichroic ratio at 825 nm in magnetically oriented chloroplasts trapped at low temperature (-170°C). The use of low temperature was necessary because of time resolution constraints of the P680 rereduction at room temperature. At such a low temperature, the absorbance change at 825 nm decays biphasically, the rapid phase (2.8 msec) being due to the rereduction of the photo-oxidized primary donor of PSII and the slow phase to its counterpart for PSI. The dichroic ratio was found to be similar for both phases, $D = 1.32$ and $1.40 \pm .05$ respectively. The authors therefore concluded that the Q_Y transition moment of the P680 has the same orientation, relatively, to the membrane plane, as the Q_Y transition moment of the P700, i.e., a tilt angle smaller than 20° .

2. PHOTOSYNTHETIC BACTERIA

Vermeiglio and Clayton (1976) were the first to report on the orientation of the reaction center pigments with respect to the membrane plane. They measured the polarized absorption of air-dried chromatophores from *Rp. sphaeroides* (R-26) in which the antenna had been selectively oxidized by K_2IrCl_6 . The 870-nm transition of the SP was found to be at less than 20° from the membrane plane, whereas the average direction of the Q_Y transitions of the two Bph molecules were tilted out of the membrane at an angle greater than 45° . The average angle between the Q_Y transition moments of the BChl molecules absorbing at 800 nm, and the membrane plane is smaller than 30° . Further information has been obtained from the LD of the light-induced absorbance changes related to the photo-oxidation of the SP (Fig. 16) (Vermeiglio and Clayton, 1976; Rafferty and Clayton, 1979b), because these changes involve only some of the RC pigments. Vermeiglio and Clayton (1976) observed that the LD had opposite signs for the increase at 790 nm ($\text{LD} > 0$) and the absorption decrease at 810 nm ($\text{LD} < 0$). This result is inconsistent with the generally assumed hypothesis of a single blue-shift of the 803 nm band in the state P^+ . They proposed an alternative hypothesis in which the 860- and 810-nm absorption decreases were attributed to the disappearance of the two excitonic components of the

FIG. 16. Polarized light minus dark difference absorption spectra of chromatophores from *Rp. sphaeroides* oriented by drying on a glass slide. The plane of the slide was vertical and tilted at 30° from the direction of the measuring beam. The electric vector of the measuring beam was either parallel to the slide plane (ΔA_{\parallel}) or at an angle of 60° with this plane (ΔA_{\perp}). (Adapted with permission from Rafferty and Clayton, 1979b.)

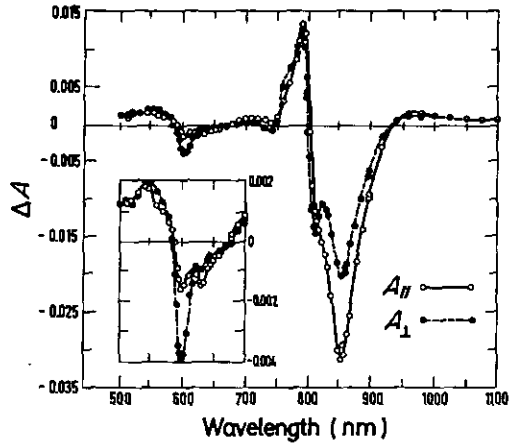

SP, whereas the 790-nm increase reflected the appearance of a monomer-like BChl absorption band.

In a subsequent study, Rafferty and Clayton (1979b) detected a small absorption decrease at 630 nm besides the large one observed at 600 nm; both were attributed to the Q_x excitonic components of the SP. From their measurements (insert of Fig. 16), an angle of 18° with the membrane plane was calculated for the 630-nm transition, whereas the 600-nm transition was found to be tilted out of the membrane plane at more than 55° in agreement with the results of Vermeglio and Clayton (1976).

Similar polarization studies have been performed with *Rp. viridis* (Paillotin *et al.*, 1979). This species presents several advantages: Whole cells can be oriented in a magnetic field, both states P^+ and $P Bph^-$ can be photoinduced at room temperature, and the absorption bands around 830 nm of the RC pigments are better resolved than for BChl *a*-containing species and well-separated from the antenna absorption. The Q_y transition moments of the two Bph molecules were found to be tilted out of the membrane plane, whereas the average direction for the Q_y transitions of the two BChl molecules not involved in the SP is inclined at $\sim 25^\circ$ from the membrane plane. Figure 17 shows the polarized absorption changes linked to the state P^+ . Qualitatively, these results are similar to the ones obtained on BChl *a*-containing species (see Fig. 16) with the 970-nm transition almost parallel to the membrane. In the 780–870-nm region, these absorption changes were interpreted (Paillotin *et al.*, 1979) as due to three different contributions: (a) bleaching at 845 nm of one excitonic component of the SP. This transition is tilted out of the membrane plane by more than 55° ; (b) appearance at 805 nm of a monomer-like BChl transition making an angle smaller than 25° with the

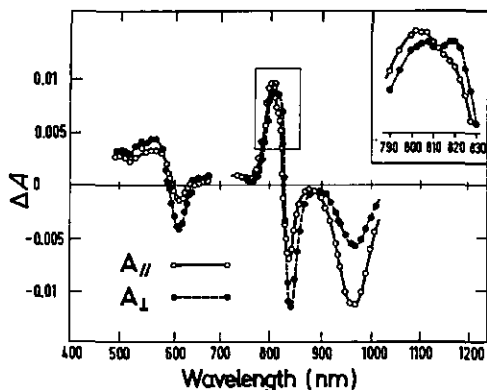

FIG. 17. Light-minus-dark difference spectra of oriented cells of *Rp. viridis* preferentially measured either parallel (ΔA_{\parallel}) or perpendicular (ΔA_{\perp}) to the chromatophore membrane plane. (From Paillotin *et al.*, 1979.)

plane of the membrane; and (c) shifts of the Q_Y transition moments of the two BChl molecules not involved in the SP; these shifts are in opposite directions. The Q_Y transition moment of one BChl is parallel to the membrane plane, whereas the transition of the other molecule makes an angle of 50° with this plane.

The polarization of the absorbance changes linked to the state P Bph⁻ has also been measured on oriented cells of *Rp. viridis* (Paillotin *et al.*, 1979) and confirms the interpretation of Van Grondelle *et al.* (1976) of both a BChl band shift and a bleaching of one of the two Bph molecules. It has been possible to demonstrate that only the BChl with its Q_Y transition moment parallel to the membrane plane is shifted due to the presence of the negative charge in the RC. This interpretation is consistent with the photoselection study of Shuvalov and Asadov (1979) for state P Bph⁻ which shows a constant polarization across the BChl band shift. The Bph molecule reduced in the state P Bph⁻ has its plane nearly perpendicular to the membrane, its Q_Y and Q_X transitions being respectively perpendicular and parallel to this plane.

ESR studies of the triplet state of the SP in oriented membranes have also been reported. This approach, complementary to the LD studies, gives information about the three magnetic axes of the BChl dimer triplet state with respect to the membrane plane.

Frank *et al.* (1979a) have shown that ESR spectra of the BChl dimer triplet state of magnetically aligned whole cells of *Rp. viridis* and *Rp. palustris* display a marked dependence on the orientation between the analyzing static field and the membrane plane. For both BChl *a* (*Rp. palustris*) and BChl *b* (*Rp. viridis*) containing cells, the orientations of the triplet axes were found to be very similar. The *z* axis was found to lie (within 15°) preferentially in the membrane plane. The two other axes *x* and *y* make an angle of about 45° with this plane.

Hales and Das Gupta (1979a) have performed similar experiments on chromatophores of *Rs. rubrum* oriented by air-drying. Although they obtained qualitatively similar dependency of the ESR triplet signals upon the orientation of the static ESR field and the membrane plane than Frank *et al.* (1979a), they came to a somewhat different orientation of the x , y , z axes with the membrane plane: the x axis is parallel to that plane, whereas the z and y axes make, respectively, an angle of 10° – 20° and 70° – 80° with that plane. Frank *et al.*, (1979b) have shown by magnetophotoselection on purified RC from *Rp. sphaeroides* R-26 that the magnetic x axis is parallel to the long wavelength transition of the SP, in accord with results of Thurnauer and Norris (1976) and Boxer and Roelofs (1979). According to Vermeglio and Clayton (1976), Rafferty and Clayton (1979b), and Paillotin *et al.* (1979), this long wavelength transition lies preferentially in the membrane plane. Therefore the magnetic axis x must lie nearly parallel to the membrane plane, making it consistent only with the positioning of the SP proposed by Hales and Das Gupta (1979a).

C. Other Constituents

1. CYTOCHROMES

Several photosynthetic Cyts have been found to be oriented with respect to the membrane plane. The first reported studies have been done by ESR on air-dried chromatophores from *Rp. viridis* (Prince *et al.*, 1978) and *Chr. vinosum* (Tiede *et al.*, 1978). In the former species, the heme of Cyt *c*-558 has been found to be oriented perpendicular to the membrane plane. In the latter, a similar orientation has been observed for Cyt *c*-555, whereas the heme of the low potential Cyt *c*-553 was found to be parallel to the membrane plane.

Using light-induced polarized absorption changes on oriented samples, Vermeglio *et al.* (1980) have studied the orientation of the hemes of the high potential Cyt *c*-558 of *Rp. viridis* and Cyt *b*-559 of spinach chloroplasts. In contrast to ESR, which detects solely the oxidized species, these optical studies allow analysis of the difference spectrum of the reduced and the oxidized species. Although a slight complication arises from the partial overlapping of X and Y polarized transitions in the α and β bands, they compared the LD spectra obtained on magnetically oriented photosynthetic membranes to the LD of Cyt *c* (oxidized or reduced) in stretched films. It was concluded in both cases that the heme of the Cyts are oriented approximately perpendicular to the membrane plane.

2. QUINONES

There are good indications that the quinones are oriented with respect to the plane of photosynthetic membranes. Dismukes *et al.* (1979) found that the two ESR features associated with the reduction of the Fe-Q complex in whole cells of *Rp. viridis* display a marked dependence on the orientation of the sample. Hales and Das Gupta (1979a) described the orientation of the primary ubiquinone in oriented membranes reconstituted from an iron-depleted fraction of *Rs. rubrum*. From the computer simulation of their ESR spectra, they concluded that the plane of the primary ubiquinone acceptor molecule was parallel to the plane of the membrane.

Hales and Das Gupta (1979b) found that in chloroplast membranes the orientation dependence of the ESR signal II_{vf} ($D_{II,2}$) could be interpreted in terms of an orientation of the normal to the quinone plane at $\sim 35^\circ$ to the plane of the membrane.

3. OTHER MEMBRANE-BOUND RADICALS

The ESR of spinach chloroplasts oriented either by flow or by a magnetic field has been investigated (Dismukes and Sauer, 1978; Dismukes *et al.*, 1978; Friesner *et al.*, 1979b). The ESR signals of several membrane-bound radicals that possess g -tensor anisotropy display orientation effects. This is the case for X ($A_{I,2}$) an early acceptor of PSI whose identity is unknown, which is oriented with its g_x component predominantly perpendicular to the membrane plane and its g_y and g_z components close to the membrane plane.

The Fe-S protein B($A_{I,3}$) acting as an acceptor of PSI is oriented with its g_y component predominantly normal to the membrane. Another Fe-S protein functioning between PSI and PSII was also found to show orientation effects. McIntosh *et al.* (1979) reported that an acceptor more primary than X ($A_{I,2}$) and depicting large anisotropic effects could be detected by rapid ESR spectroscopy. In the same study, they also observed an orientation-dependent ESR signal from Mn^{2+} .

Slabas and Evans (1977) reported that ESR signals from an unknown paramagnetic species, probably reflecting the oxidation states of the oxygen-evolving system, in spinach chloroplast show strong orientation effects when they used an anisotropic sample. This was later confirmed by Dismukes and Sauer (1978). However, no further work is available on this system.

4. PROTEINS

A rather large fraction ($\sim 50\%$) of the intrinsic proteins of photosynthetic membranes is in α -helical conformation. By measuring the IR

spectra of chromatophores (from *Rp. sphaeroides* or *Rp. palustris*), which were either at random or oriented parallel to a plane disk, Breton (1979) measured the orientation of these α -helices. A comparison of these data to similar results obtained with purple membranes from *Halobacterium halobium*, in which the orientation of the α -helices was already known (Henderson, 1975), leads to the conclusion that the axes of the α -helices are on the average tilted at $29^\circ \pm 10^\circ$ from the normal at the chromatophore membrane plane. A qualitatively similar observation has been seen for air-dried membranes of spinach chloroplasts by measuring directly the LD in the IR (Nabedryk and Breton 1981). This observation shows that a previous interpretation of the LD in the far UV (180–220 nm) as indicative of an orientation parallel to the membrane plane of the axis of the α -helices (Breton *et al.*, 1973a) was incorrect. Rather, the LD signals in this complex spectral range might reflect the various orientations of the several types of aromatic amino acid residues.

V. Local Order between Complexes in Photosynthetic Membranes

Photosynthetic membranes possess a unique characteristic for studying the problem of local order between adjacent complexes because of the transfer of excitation energy among them.

The measurement of the extent of depolarization of Chl fluorescence *in vivo* to estimate the number of transfer steps has been applied for a long time (Arnold and Meek, 1956; Goedheer, 1957, 1973; Teale, 1960; Lavorel, 1964; Ebrey and Clayton, 1969; Ebrey, 1971; Mar and Govindjee, 1972; Wong and Govindjee, 1981). However, two important facts were not clearly recognized at that time. First of all, a steady state measurement of fluorescence depolarization leads only to a convolution of the number of transfer steps by the averaged angular factor of the transition moments between which the transfer occurs. Second, the fluorescence polarization of a random suspension of membranes in which the pigments are oriented with respect to the membrane plane cannot be assimilated to an isotropic solution of pigments, since photoselection of membranes will occur and will appreciably distort the data. This effect was first described by Breton *et al.* (1973b), who have also shown that true depolarization by energy transfer between mutually oriented chromatophores had to be studied on an oriented sample in which the fluorescence viewing direction was along the normal to the membrane plane. This photoselection effect can explain the results of Ebrey and Clayton (1969) on chromatophores isolated from photosynthetic bacteria where they observed upon excitation at 590 nm a polarization which was too

large as compared to the one measured when exciting at 850 nm. There is no need to invoke either anomalous energy transfer (Ebrey, 1971) or textural effects (Goedheer, 1973) to explain this discrepancy (Breton, 1977b).

It must be noted that the most readily interpretable data are those obtained upon excitation in a region where the intrinsic polarization of fluorescence for the isolated pigment is maximum and that the measurement of p for pigments in the membrane cannot be larger than the one determined for the isolated pigment-protein complexes.

In green plants there are some indications (Whitmarsh and Levine, 1974; Becker *et al.*, 1976, Garab and Breton, 1976) that the degree of local order between the Q_y transition moments of Chl *a* increases from the shorter toward the longer wavelength absorbing species (although a reduction in the number of transfer steps cannot be excluded). There is also evidence that the Car molecules and the Q_y transition moments of Chl *a* tend to be mutually oriented at a small angle at a local level (Becker *et al.*, 1976). Only one magnetophotoselection experiment has been performed with photosynthetic bacteria which, although qualitatively, seems to indicate that local order is present between antenna complexes as well as between antenna and RC complexes (Thurnauer and Norris, 1976).

Finally, the use of singlet-singlet annihilation as a tool to reduce the extent of energy migration between the pigments complexes has been proposed in order to study the local order between subsets of neighboring pigments (Breton and Geacintov, 1979).

VI. Conclusions

During the last 10 years, the use of linearly polarized light has revealed a high degree of organization of the pigments and of the electron transfer components in photosynthetic material. However, the orientation of the chromophores either with respect to the plane of the photosynthetic membrane or within isolated pigment-protein complexes has been so far described in qualitative (or at the best semiquantitative) terms. Various intrinsic limitations like the overlap of several absorption bands, the lack of perfect polarization of some transitions, the divergent interpretations of the absorption changes are responsible for this imprecision. It is nevertheless interesting to note the similarity of the organization of photosynthetic membrane in bacteria and green plants. In both classes of organisms, most of the antenna Chls are found to be preferentially oriented perpendicular to the membrane plane; a similar

orientation is also deduced for the two Chl molecules of the primary donors. On the other hand, the Car molecules are closer to the membrane plane in green plants than in photosynthetic bacteria.

Beside the qualitative description of these orientations, we lack direct information on the distance between the chromophores and on the angles between the vectors joining the center of the different molecules. The absence of these two parameters precludes any complete description of the disposition of the chromophores. Different methods, however, permit an estimation of distances between molecules. For example, in the case of a dimer, the rotational strength of the CD bands depends upon a triple product involving the two transition moments of each monomer and a vector joining the center of the two molecules (Tinoco, 1963). The electronic interaction energy depends also on the geometrical relationship of the transition moment and their distances. These properties have been recently used to estimate a distance of $\sim 10 \text{ \AA}$ between the antenna BChl *a* molecules in the B890 complex of R-26 (G. Paillotin, private communication). The distance between electron carriers can also be determined by measurements of the rate of electron transfer between these molecules (Hopfield, 1974; Jortner, 1976; Peters *et al.*, 1978) or by determination of the magnetic exchange coupling constant between two paramagnetic species (Tiede *et al.*, 1978; Okamura *et al.*, 1979a, b).

A hypothetical model of a photosynthetic membrane, which tentatively includes information on the orientations as well as on the distances of RC and antenna chromophores, is depicted in Fig. 18. Further ex-

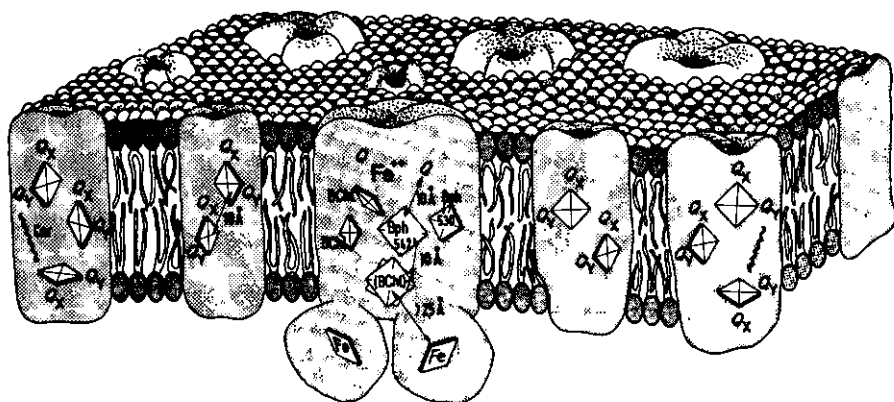

FIG. 18. Schematic representation of RC and LH chromophores in the membrane of a photosynthetic bacteria. Information obtained from different species have been pooled in drawing this model.

periments need to be designed in order to improve such models. This will necessitate the determination of the degree of orientation of the membranes or of the particles in the sample under investigation. The combination of ESR and absorption techniques, the availability of purified antenna and RC from green plants and a variety of refinements in the experimental conditions should increase our understanding of the orientation of the chromophores *in vivo*. However, further progress will probably require the use of some modeling. In this respect, the availability of various synthetic Chl dimers or complexes of known structure and bearing some resemblance with the models derived from the studies described in this chapter would be of considerable help. They would allow the development of proper theories for absorption, CD, and ESR, which could then be applied to the interpretation of the physical properties of natural Chl-protein complexes.

Acknowledgments

We are indebted to the photosynthesis group of CEN Saclay for helpful criticisms on the manuscript. We wish to thank S. Reinmann and N. Geacintov for a careful reading of the manuscript and G. Paillotin for many constructive discussions.

REFERENCES

- Abdourakhamanov, I. A., Ganago, A. O., Erokhin, Y. E., Solov'ev, A. A., and Chugunov, V. A. (1979). *Biochim. Biophys. Acta* **546**, 183-186.
- Albrecht, A. C. (1961). *J. Mol. Spectrosc.* **6**, 84-108.
- Arnold, W., and Meeck, E. S. (1956). *Arch. Biochem. Biophys.* **60**, 82-90.
- Becker, J. F., Geacintov, N. E., Van Nostrand, F., and Van Metter, R. (1973). *Biochem. Biophys. Res. Commun.* **51**, 597-602.
- Becker, J. F., Breton, J., Geacintov, N. E., and Trentacosti, F. (1976). *Biochim. Biophys. Acta* **440**, 531-544.
- Bengis, C., and Nelson, N. (1975). *J. Biol. Chem.* **250**, 2783-2788.
- Biggins, J., and Svejksky, J. (1978). *FEBS Lett.* **89**, 201-204.
- Bolt, J., and Sauer, K. (1979). *Biochim. Biophys. Acta* **546**, 54-63.
- Boxer, S. G., and Roelofs, M. G. (1979). *Proc. Natl. Acad. Sci. U.S.A.* **76**, 5636-5640.
- Breton, J. (1974). *Biochem. Biophys. Res. Commun.* **59**, 1011-1017.
- Breton, J. (1975). *Proc. Int. Congr. Photosynth.*, 3rd, 1974 Vol. I, pp. 229-234.
- Breton, J. (1977a). *Biochim. Biophys. Acta* **459**, 66-75.
- Breton, J. (1977b). Doctoral Thesis, University of Paris Sud.
- Breton, J. (1979). *7th Annu. Meet. Am. Soc. Photobiol.*, 1979 Abstract MPM-C4.
- Breton, J., and Geacintov, N. E. (1979). In "Chlorophyll Organization and Energy Transfer in Photosynthesis" (Ciba Found.), pp. 217-236. Excerpta Medica, Amsterdam.
- Breton, J., and Mathis, P. (1974). *Biochem. Biophys. Res. Commun.* **58**, 1071-1078.
- Breton, J., and Paillotin, G. (1977). *Biochim. Biophys. Acta* **459**, 58-65.

- Breton, J., and Roux, E. (1971). *Biochem. Biophys. Res. Commun.* **45**, 557–563.
- Breton, J., Michel-Villaz, M., and Paillotin, G. (1972a). *Photosynth., Two Centuries Its Discovery Joseph Priestley, Proc. Int. Congr. Photosynth. Res., 2nd, 1971 Vol. I*, pp. 349–357.
- Breton, J., Michel-Villaz, M., Paillotin, G., and Vandevyver, M. (1972b). *Thin Solid Films* **13**, 351–357.
- Breton, J., Michel-Villaz, M., and Paillotin, G. (1973a). *Biochim. Biophys. Acta* **314**, 42–56.
- Breton, J., Becker, J. F., and Geacintov, N. E. (1973b). *Biochem. Biophys. Res. Commun.* **54**, 1403–1409.
- Breton, J., Roux, E., and Whitmarsh, J. (1975). *Biochem. Biophys. Res. Commun.* **64**, 1274–1277.
- Breton, J., Vermeglio, A., Garrigos, M., and Paillotin, G. (1981). *Proc. Int. Congr. Photosynth., 5th, 1980 Vol. III*, pp. 445–459.
- Butler, W. L., Olson, R. A., and Jennings, W. H. (1964). *Biochim. Biophys. Acta* **88**, 651–653.
- Cherry, R. J., Kwan Hsu, and Chapman, D. (1972). *Biochim. Biophys. Acta* **267**, 512–522.
- Clayton, R. K. (1980). "Photosynthesis: Physical Mechanisms and Chemical Patterns." Cambridge Univ. Press, London and New York.
- Clayton, R. K., and Yamamoto, T. (1976). *Photochem. Photobiol.* **24**, 67–70.
- Clayton, R. K., Rafferty, C. N., and Vermeglio, A. (1979). *Biochim. Biophys. Acta* **545**, 58–68.
- Clement-Metral, J. D. (1975). *FEBS Lett.* **50**, 257–260.
- Demeter, S., Sagromsky, H., and Faludi-Daniel, A. (1976). *Photosynthetica* **10**, 193–197.
- Dismukes, G. C., and Sauer, K. (1978). *Biochim. Biophys. Acta* **504**, 431–445.
- Dismukes, G. C., McGuire, A., Blankenship, R., and Sauer, K. (1978). *Biophys. J.* **21**, 239–256.
- Dismukes, G. C., Frank, H. A., Friesner, R., and Sauer, K. (1979). *Biophys. J.* **25**, 54a.
- Dutton, P. L., Leigh, J. S., Prince, R. C., and Tiede, D. M. (1979). In "Tunneling in Biological Systems" (B. Chance, D. Devault, H. Frauenfelder, R. A. Marcus, J. R. Schrieffer, and N. Sutin, eds.), pp. 319–354. Academic Press, New York.
- Ebrey, T. G. (1971). *Biochim. Biophys. Acta* **253**, 385–395.
- Ebrey, T. G., and Clayton, R. K. (1969). *Photochem. Photobiol.* **10**, 109–117.
- Faludi-Daniel, A., and Breton, J. (1975). *Photochem. Photobiol.* **22**, 125–127.
- Frank, H. A., Friesner, R., Nairn, J. A., Dismukes, G. C., and Sauer, K. (1979a). *Biochim. Biophys. Acta* **547**, 484–501.
- Frank, H. A., Bolt, J., Friesner, R., and Sauer, K. (1979b). *Biochim. Biophys. Acta* **547**, 502–511.
- Frey-Wyssling, A., and Wuhrmann, K. (1947). *Helv. Chim. Acta* **30**, 20–23.
- Friesner, R., Nairn, J. A., and Sauer, K. (1979a). *J. Chem. Phys.* **71**, 358–365.
- Friesner, R., Dismukes, G. C., and Sauer, K. (1979b). *Biophys. J.* **25**, 277–294.
- Gagliano, A. G., Geacintov, N. E., and Breton, J. (1977). *Biochim. Biophys. Acta* **461**, 460–474.
- Gagliano, A. G., Geacintov, N. E., Breton, J., Acker, S., and Remy, R. (1979). *Photochem. Photobiol.* **29**, 415–418.
- Garab, G. I., and Breton, J. (1976). *Biochem. Biophys. Res. Commun.* **71**, 1095–1102.
- Geacintov, N. E., Van Nostrand, F., and Tinkel, J. B. (1972a). *Photosynth., Two Centuries Its Discovery Joseph Priestley, Proc. Int. Congr. Photosynth. Res., 1971 Vol. I*, pp. 283–290.
- Geacintov, N. E., Van Nostrand, F., Becker, J. F., and Tinkel, J. B. (1972b). *Biochim. Biophys. Acta* **267**, 65–79.
- Geacintov, N. E., Van Nostrand, F., and Becker, J. F. (1974). *Biochim. Biophys. Acta* **347**, 443–463.
- Goedheer, J. C. (1955). *Biochim. Biophys. Acta* **16**, 471–476.

- Goedheer, J. C. (1957). Doctoral Thesis, University of Utrecht, The Netherlands.
- Goedheer, J. C. (1973). *Biochim. Biophys. Acta* **292**, 665-676.
- Gouterman, M. (1961). *J. Mol. Spectrosc.* **6**, 138-163.
- Gregory, R. P. F. (1977). *Top. Photosynth.* **2**, 465-492.
- Hales, B. J., and Das Gupta, A. (1979a). *Biochim. Biophys. Acta* **548**, 276-286.
- Hales, B. J., and Das Gupta, A. (1979b). *Biophys. J.* **25**, 51a.
- Henderson, R. (1975). *J. Mol. Biol.* **93**, 123-138.
- Hoff, A. J. (1974). *Photochem. Photobiol.* **19**, 51-57.
- Hoff, A. J. (1982). In "Light Reaction in Photosynthesis" (F. K. Fong, ed.), Springer-Verlag, Berlin and New York.
- Hofrichter, J., and Eaton, W. A. (1976). *Annu. Rev. Biophys. Bioeng.* **5**, 511-560.
- Hong, F. T., Mauzerall, D., and Mauro, A. (1971). *Proc. Natl. Acad. Sci. U.S.A.* **68** 1283-1285.
- Hopfield, J. (1974). *Proc. Natl. Acad. Sci. U.S.A.* **71**, 3640-3644.
- Jortner, J. (1976). *J. Chem. Phys.* **64**, 4860-4867.
- Journeaux, R., and Viovy, P. (1978). *Photochem. Photobiol.* **28**, 243-248.
- Junge, W. (1975). *Proc. Int. Congr. Photosynth.* 3rd, 1974 Vol. I, pp. 273-286.
- Junge, W., and Eckhof, A. (1973). *FEBS Lett.* **36**, 207-212.
- Junge, W., and Eckhof, A. (1974). *Biochim. Biophys. Acta* **357**, 103-117.
- Junge, W., and Schaffernicht, H. (1978). *Proc. Int. Congr. Photosynth.*, 4th, 1977 pp. 31-32.
- Junge, W., and Schaffernicht, H. (1979). In "Chlorophyll Organization and Energy Transfer in Photosynthesis" (Ciba Found.), pp. 127-146. Excerpta Medica, Amsterdam.
- Junge, W., Schaffernicht, H., and Nelson, N. (1977). *Biochim. Biophys. Acta* **462**, 73-85.
- Knox, R. S., and Davidovich, M. A. (1978). *Biophys. J.* **24**, 689-712.
- Knox, R. S., and Van Metter, R. L. (1979). In "Chlorophyll Organization and Energy Transfer in Photosynthesis" (Ciba Found.), pp. 117-190. Excerpta Medica, Amsterdam.
- Lavorel, J. (1964). *Biochim. Biophys. Acta* **88**, 20-36.
- Libertini, L. J., Waggoner, A. S., Jost, P. C., and Griffith, O. H. (1969). *Proc. Natl. Acad. Sci. U.S.A.* **64**, 13-19.
- Lutz, M., Agalidis, I., Hervo, G., Cogdell, R. J., and Reiss-Husson, F. (1978). *Biochim. Biophys. Acta* **503**, 287-303.
- McIntosh, A., Manikowski, H., and Bolton, J. R. (1979). *J. Phys. Chem.* **83**, 3309-3313.
- Mailer, C., and Taylor, C. P. S. (1972). *Can. J. Biochem.* **50**, 1048-1055.
- Mar, T., and Gingras, G. (1976). *Biochim. Biophys. Acta* **440**, 609-621.
- Mar, T., and Govindjee (1972). *Photosynth., Two Centuries Its Discovery Joseph Priestley, Proc. Int. Congr. Photosynth. Res.*, 2nd, Vol. I, pp. 271-281.
- Mathis, P., Breton, J., Vermeiglio, A., and Yates, M. (1976). *FEBS Lett.* **63**, 171-173.
- Matthews, B. W., Fenna, R. E., Bolognesi, M. C., Schmid, M. F., and Olson, J. M. (1979). *J. Mol. Biol.* **131**, 259-285.
- Menke, W. (1943). *Biol. Zentralbl.* **63**, 326-349.
- Morita, S., and Miyazaki, T. (1971). *Biochim. Biophys. Acta* **245**, 151-159.
- Morita, S., and Miyazaki, T. (1978). *J. Biochem. (Tokyo)* **83**, 1715-1720.
- Nabedryk, E., and Breton, J. (1981). *Biochim. Biophys. Acta* **635**, 515-524.
- Nishijima, Y., Onogi, Y., and Asai, T. (1966). *J. Polym. Sci.* **15**, 237-250.
- Okamura, M. Y., Fredkin, D. R., Isaacson, R. A., and Feher, G. (1979a). In "Tunneling in Biological Systems" (B. Chance, D. Devault, H. Frauenfelder, R. A. Marcus, J. R. Schrieffer, and N. Sutin, eds.), pp. 729-743. Academic Press, New York.
- Okamura, M. Y., Isaacson, R. A., and Feher, G. (1979b). *Biochim. Biophys. Acta* **546**, 394-417.
- Olson, R. A. (1970). *Science* **169**, 81-82.

- Olson, R. A., Jennings, W. H., and Butler, W. L. (1964). *Biochim. Biophys. Acta* **88**, 318–330, 331–337.
- Olson, R. A., Jennings, W. H., and Olson, J. M. (1969). *Arch. Biochem. Biophys.* **129**, 30–41.
- Pailotin, G., and Breton, J. (1977). *Biophys. J.* **18**, 63–79.
- Pailotin, G., Vermeglio, A., and Breton, J. (1979). *Biochim. Biophys. Acta* **545**, 249–264.
- Penna, F. J., Reed, D. W., and Ke, B. (1975). *Proc. Int. Congr. Photosynth.*, 3rd, 1974 Vol. I, pp. 421–425.
- Peters, K., Avouris, P., and Rentzepis, P. M. (1978). *Biophys. J.* **23**, 207–214.
- Petke, J. D., Maggiora, G. M., Shipman, L., and Christoffersen, R. Č. (1979). *Photochem. Photobiol.* **30**, 203–223.
- Prince, R. C., Tiede, D. M., Leigh, J. S., and Dutton, P. L. (1978). *Int. Biophys. Congr. 6th, 1978* Abstract V-25.
- Rafferty, C. N., and Clayton, R. K. (1978). *Biochim. Biophys. Acta* **502**, 51–60.
- Rafferty, C. N., and Clayton, R. K. (1979a). *Biochim. Biophys. Acta* **545**, 106–121.
- Rafferty, C. N., and Clayton, R. K. (1979b). *Biochim. Biophys. Acta* **546**, 189–206.
- Reed, D. W., and Ke, B. (1973). *J. Biol. Chem.* **248**, 3041–3045.
- Ruch, F. (1957). *Exp. Cell Res., Suppl.* **4**, 58–63.
- Sadler, D. M., Lefort-Tran, M., and Pouphele, M. (1973). *Biochim. Biophys. Acta* **298**, 620–629.
- Salem, L. (1966). In "The Molecular Orbital Theory of Conjugated Systems" (L. Salem, ed.), pp. 379–383. Benjamin, New York.
- Sauer, K. (1965). *Biophys. J.* **5**, 337–348.
- Sauer, K., and Calvin, M. (1962). *J. Mol. Biol.* **4**, 451–466.
- Shuvalov, V. A., and Asadov, A. A. (1979). *Biochim. Biophys. Acta* **545**, 296–308.
- Shuvalov, V. A., Asadov, A. A., and Krakhmaleva, I. N. (1977). *FEBS Lett.* **76**, 240–245.
- Slabas, A. R., and Evans, M. C. W. (1977). *Nature (London)* **270**, 169–171.
- Sperling, W., and Ke, B. (1966). *Photochem. Photobiol.* **5**, 865–876.
- Staelin, L., Armond, P. A., and Miller, K. R. (1977). *Brookhaven Symp. Biol.* **28**, 278–315.
- Sutherland, J. C., and Klein, M. P. (1972). *J. Chem. Phys.* **57**, 76–86.
- Teale, F. W. J. (1960). *Biochim. Biophys. Acta* **42**, 69–75.
- Thomas, J. B., Van Lierop, J. H., and Ten Ham, M. (1967). *Biochim. Biophys. Acta* **143**, 204–220.
- Thornber, J. P., and Barber, J. (1979). *Top. Photosynth.* **3**, 27–70.
- Thornber, J. P., Trospen, T. L., and Strouse, C. E. (1978). In "The Photosynthetic Bacteria" (R. K. Clayton and W. R. Sistrom, eds.), pp. 133–160. Plenum, New York.
- Thornber, J. P., Markwell, J. P., and Reinman, S. (1979). *Photochem. Photobiol.* **29**, 1205–1216.
- Thurnauer, M. C., and Norris, J. R. (1976). *Biochem. Biophys. Res. Commun.* **73**, 501–506.
- Thurnauer, M. C., and Norris, J. R. (1977). *Chem. Phys. Lett.* **47**, 100–105.
- Tiede, D. M., Leigh, J. S., and Dutton, P. L. (1978). *Biochim. Biophys. Acta* **503**, 524–544.
- Tinoco, I., Jr. (1963). *Radial. Res.* **20**, 133–142.
- Tjernelund, T., Norden, B., Akerlund, H. E., Andersson, B., and Albertsson, P. A. (1977). In "Linear Dichroism Spectroscopy" (B. Norden, ed.), pp. 224–228. Lund Univ. Press, Lund, Sweden.
- Tsuboi, M. (1962). *J. Polym. Sci.* **58**, 139–153.
- Vacek, K., Wong, D., and Govindjee (1977). *Photochem. Photobiol.* **26**, 269–276.
- Van Grondelle, R., Romijn, J. C., and Holmes, N. C. (1976). *FEBS Lett.* **72**, 187–192.
- Van Metter, R. L. (1977a). Ph.D Thesis, University of Rochester, Rochester, New York.
- Van Metter, R. L. (1977b). *Biochim. Biophys. Acta* **462**, 642–658.
- Vermeglio, A., and Clayton, R. K. (1976). *Biochim. Biophys. Acta* **449**, 500–515.

- Vermeglio, A., Breton, J., and Mathis, P. (1976). *J. Supramol. Struct.* **5**, 109–117.
- Vermeglio, A., Breton, J., Paillotin, G., and Cogdell, R. J. (1978). *Biochim. Biophys. Acta* **501**, 514–530.
- Vermeglio, A., Breton, J., and Gagliano, A. G. (1979). *7th Annu. Meet. Am. Soc. Photobiol.*, 1979 Abstract MPM-c11.
- Vermeglio, A., Breton, J., Barouch, Y., and Clayton, R. K. (1980). *Biochim. Biophys. Acta* **593**, 299–311.
- Whitmarsh, J., and Levine, R. P. (1974). *Biochim. Biophys. Acta* **368**, 199–213.
- Whitten, W. B., Pearlstein, R. M., Phares, E. F., and Geacintov, N. E. (1978). *Biochim. Biophys. Acta* **503**, 491–498.
- Wong, D., and Govindjee (1981). *Photochem. Photobiol.* **33**, 103–108.

Reaction Centers

MELVIN Y. OKAMURA
 GEORGE FEHER
 NATHAN NELSON

I. Introduction.....	196
A. Definition of a Reaction Center (RC).....	198
B. Assays for Photochemical Activity.....	198
C. Fractionation of Photosynthetic Membranes with Detergents.....	199
II. Photosynthetic Bacteria.....	200
A. Purple Bacteria.....	201
B. Green Bacteria.....	228
III. Green Plant Photosystems.....	229
A. Photosystem I.....	230
B. Photosystem II.....	249
IV. Concluding Remarks.....	256
V. Appendix.....	262
References.....	264

ABBREVIATIONS

A	Acceptor
BChl	Bacteriochlorophyll
Bph	Bacteriopheophytin
Car	Carotenoids
CD	Circular dichroism
Chl	Chlorophyll
<i>Chr.</i>	<i>Chromatium</i>
Cyt	Cytochrome
D	Donor
DEAE	Diethylaminoethyl
DMSO	Dimethylsulfoxide
$E_{m,7}$	Midpoint potential at pH 7.0
ENDOR	Electron nuclear double resonance
ESR(EPR)	Electron spin (paramagnetic) resonance
EXAFS	Extended X-ray absorption fine structure
FeS	Iron-sulfur
G	Gauss
kD	Kilodalton
LDAO	Lauryldimethylamine oxide
LDS	Lithium dodecylsulfate
L-M-H	Light-Medium-Heavy subunits of the bacterial RC

MQ	Menaquinone
MW	Molecular weight
NAD	Nicotinamide adenine dinucleotide
NADP	NAD phosphate
P680, P700, P870	Primary donors/reaction center Chl or BChl of PSII, PSI, or bacterial system, respectively
PC	Plastocyanin
Ph	Pheophytin
PQ	Plastoquinone
PSI	Photosystem I
PSII	Photosystem II
Q _I	Primary quinone acceptor; also called Q _A or A ₂
Q _{II}	Secondary quinone acceptor; also called Q _B or A ₃
RC	Reaction Center
<i>Rp.</i>	<i>Rhodospseudomonas</i>
<i>Rs.</i>	<i>Rhodospirillum</i>
SDS	Sodium dodecyl sulfate
SDS-PAGE	Sodium dodecyl sulfate-polyacrylamide gel electrophoresis
UQ	Ubiquinone

ABSTRACT

Recent biochemical and spectroscopic studies of reaction centers from bacteria and green plants have shown them to have remarkable similarities. Some general characteristics of RCs are:

1. They are membrane bound proteins containing chlorophyll or bacteriochlorophyll. There is a possible homology between the protein components, which suggests a common origin.
2. They all contain a number (~4-6) of electron transfer components. These serve to convert the energy of the absorbed photon into electrochemical energy by electron transfer through a series of donor-acceptor species stabilized for increasingly longer times and separated by increasingly longer distances.
3. The initial donor-acceptor species are tetrapyrrole molecules (chlorophyll or bacteriochlorophyll derivatives).
4. The primary donor species (P680, P700, P870) exhibit optical spectra shifted to long wavelengths indicative of interactions of the tetrapyrroles with their surroundings. For bacteria, ESR data show that the primary donor is a dimer. The identity of the donors in green plants has not been definitely established.

In addition, there are striking similarities between the electron acceptors in RCs of photosystem II and those of bacteria. Both appear to have a Mg-free tetrapyrrole (pheophytin or bacteriopheophytin) and an Fe-quinone complex (plastoquinone or ubiquinone) as acceptor species. Subsequent electron transfer in both systems proceeds through a cytochrome *b* containing complex, which generates ATP. A possible scenario for the evolutionary relation between photosynthetic organisms is also discussed.

I. Introduction

Photosynthesis is the biological process of converting electromagnetic radiation into chemical energy. A simplified picture of the primary pro-

cess of photosynthesis is shown in Fig. 1. Light is absorbed by pigment molecules in an antennae complex, followed by transfer of the excitation energy to a specialized, membrane bound chlorophyll (Chl) or bacteriochlorophyll, (BChl) containing complex called the *reaction center* (RC). It is the RC that performs the primary photochemistry: a light-induced electron transfer from a donor species D^* that acts as the primary donor, also called P , to an acceptor species A . The energy stored in the charge separation is supplied by light and is used by the organism to drive electron transfer reactions that provide energy for the synthesis of stable "energy rich" compounds (e.g., ATP from ADP or carbohydrates from CO_2).

There have been great advances in our knowledge of photosynthetic RCs since their existence was first postulated by Emerson and Arnold (1932) and Gaffron and Wohl (1936). These advances have been largely due to the use of spectroscopic and biochemical methods of characterization. In this chapter, we will examine the results of spectroscopic and biochemical studies of RCs from bacteria and green plants and emphasize the structural aspects. Parson and Ke will discuss the primary photochemical reaction in more detail in Chapter 8 of this volume. Since various aspects of RC research have been reviewed (Loach, 1976; Dutton *et al.*, 1977; Feher and Okamura, 1977, 1978; Gingras, 1978; Blankenship and Parson, 1978; Hoff, 1979; Olson and Thornber, 1979; Sauer, 1979), we shall be selective rather than comprehensive in our coverage.

A. Definition of a Reaction Center (RC)

The RC is defined in terms of a unit capable of the photochemical charge separation shown in Fig. 1 where D and A are called the primary donor and acceptor species. The charge separation associated with these reactants is stabilized with respect to recombination for times of the

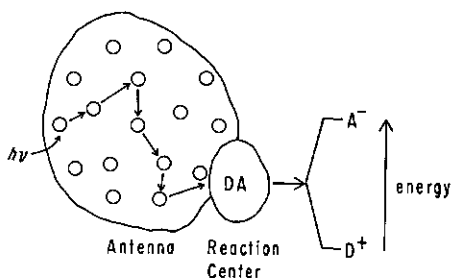

FIG. 1. Schematic representation of the light ($h\nu$) induced charge separation process in photosynthesis. The diagram depicts a photosynthetic unit. D is the reaction center Chl; A is the electron acceptor.

*The donor D is the primary donor and is labeled as P (for $P700$, $P870$, etc.) in most of the chapters in this book—editor.

order of seconds, conveniently measurable in a biochemical laboratory. The primary donor species have been found to be chlorophyll or bacteriochlorophyll species, P870, P700, and P680, and the primary acceptor species either quinones or Fe-S proteins. However, more recently it has become evident that the photochemical reactions in photosynthetic organisms are much more complicated. The electron is transferred from the primary donor to the primary acceptor through one or more intermediate acceptor species. Charge separation within the primary donor-intermediate acceptor complexes are stabilized for times of the order of nanoseconds (10^{-9} sec), and requires special techniques for detection. The intermediate acceptor species in these complexes have been found to be tetrapyrrole molecules, Chl, or Ph or their bacterial analogs. Sub-RC structural units which display this activity have been isolated. RC preparations containing a wide variety of additional components have been obtained. In this chapter we will use the term *RC complex* for these isolated RC preparations regardless of the number of additional donor, acceptor, or antennae components that are still present. For instance, even the purest preparations of green plant RCs contain a complement of ~ 30 Chl *a* molecules.

B. Assays for Photochemical Activity

A functional assay for RC activity is the light-induced transfer of charge from a donor to an acceptor. Generally, one monitors the optical or ESR spectrum of a donor or acceptor species when the sample is exposed to light. The light-induced change should have a high quantum efficiency and should be reversible, either by adding suitable donors or acceptors or by recombination in the dark. In addition, the primary photochemical reactions are expected to occur at cryogenic temperatures.

There are complications in assaying the primary photochemical reactions. Their origins lie in the back reactions that are illustrated in the simplified reaction scheme shown in Fig. 2. The light absorption results in the formation of an excited state from which electron transfer from the primary donor D_1 , to a primary acceptor A_1 , occurs. The charge recombination of the $D_1^+A_1^-$ pair, which would lead to dissipation of the excitation energy, must be avoided. Consequently, a subsequent electron transfer to a secondary acceptor species occurs with a rate faster than the recombination rate (i.e., $k_2 > k_{D_1}$). The charges of the new state $D_1^+A_2^-$ can also recombine. However, since the new donor-acceptor pair is now farther apart than the original pair, $D_1^+A_1^-$, the decay rate will be slower. Thus, a sequence of electron transfers to successive donors and acceptors results in a stabilization of the charge separation for longer periods

FIG. 2. Initial electron transfer steps of the charge separation process following excitation of the primary donor D_1 . For an effective electron transfer the back reactions rates (k_{-1} , k_{-2} , k_{D1} , k_{D2}) should be small compared to the forward rates. The faster the back reactions the higher the light intensity required to observe the charge separated state. A_1 is the first electron acceptor; A_2 is the second electron acceptor.

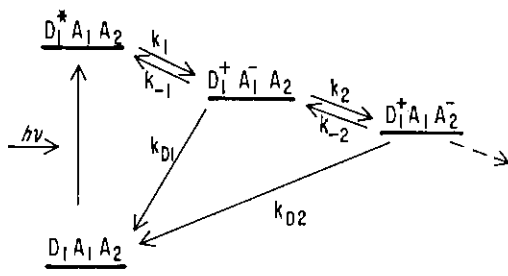

of time. It is also necessary that the ratio of forward to backward rates be large (e.g., $k_1/k_{-1} \gg 1$). This requires that successive states are lower in energy.

The presence of a back reaction means that the photochemical activity exhibited by a given RC preparation, i.e., the oxidation or reduction of a particular donor-acceptor pair, depends critically on the recombination rate as well as the light intensity. Traditionally, this means that to observe photochemical bleaching during continuous illumination using a tungsten filament lamp ($I \cong 100 \text{ mW/cm}^2$), the back reaction rate k_D should be slower than $\sim 10^3 \text{ sec}^{-1}$. Lack of observing such activity may not mean that the particular preparation does not perform light-induced charge separation but may mean that the charge recombination is too fast. This is particularly true for RCs lacking the primary acceptor since the decay rates for the initial reactions are often as high as $\sim 10^9 \text{ sec}^{-1}$.

Several approaches may be used to demonstrate photochemical activity of RCs in the presence of fast back reactions. (1) Fast photochemical techniques using pulsed light sources may be used to detect transient changes. (2) Low temperature may be used to slow down the back reaction. (3) Auxiliary donors and acceptors may be added to the RC to trap reduced acceptors and oxidized donors produced photochemically (e.g., often continuous illumination at room temperature will oxidize the donor since O_2 can serve as an exogenous acceptor). (4) Light induced ESR spectroscopy should show a spin polarized triplet signal arising from charge recombination within the radical pair $D^+ A^-$.

C. Fractionation of Photosynthetic Membranes with Detergents

Photosynthetic RCs from bacteria and green plants are membrane proteins; consequently, the procedures used for their isolation require

extraction with detergent. A number of different detergents have been used to obtain RC preparations of different purities and activities (see Table I). The mild detergent, digitonin, has been used extensively in separating the two photosystems (PSI and PSII) in green plants. These preparations generally contain many electron transfer components. Triton X-100 and LDAO are both still relatively mild but stronger than digitonin. They have been used to separate RC protein complexes from phospholipids and weakly associated membrane proteins. LDAO has been used extensively to isolate very pure RCs from bacteria, whereas Triton has been used more extensively in isolating RC complexes from green plant. The strong anionic detergent SDS tends to dissociate proteins into individual polypeptide subunits. Reaction center complexes from both bacteria and PSI of green plants may be prepared with SDS treatment. These represent the smallest RC complexes. Some of these complexes lack the primary acceptor and are inactive when examined using continuous illumination, but they show activity when illuminated with strong laser pulses.

Several promising new approaches have been used to isolate RCs. The detergent LDS (lithium dodecyl sulfate) has properties similar to SDS but can be used at low (4°C) temperatures at which SDS precipitates from solution. It has been used to isolate a Chl-protein complex from *Chlamydomonas* (Delepelaire and Chua, 1979), which is a RC complex of PSII. Several procedures have been used to extend the range of detergents. One approach has been to use mixtures of two detergents, such as SDS and LDAO (Okamura *et al.*, 1974). Another approach has been to use a detergent together with a "chaotropic" agent, such as LiClO₄, which tends to dissociate protein aggregates (Feher and Okamura, 1978). In another procedure urea (U) together with Triton X-100 (T) at alkaline (A) pH was used to produce RC complexes (also called AUT particles) from photosynthetic bacteria (Loach, 1976). Affinity chromatography using a column of Cyt *c* has been used to purify RCs from bacteria and PSI (Brudvig *et al.*, 1982). This general approach utilizing selective binding of RCs to various proteins and cofactors is very promising.

II. Photosynthetic Bacteria

The bacterial photosynthetic system is relatively simple consisting of a single RC that drives a variety of electron transfer reactions [for a comprehensive review of photosynthetic bacteria, see Clayton and Sistrom (1978)]. In purple bacteria, the RC drives cyclic electron transport,

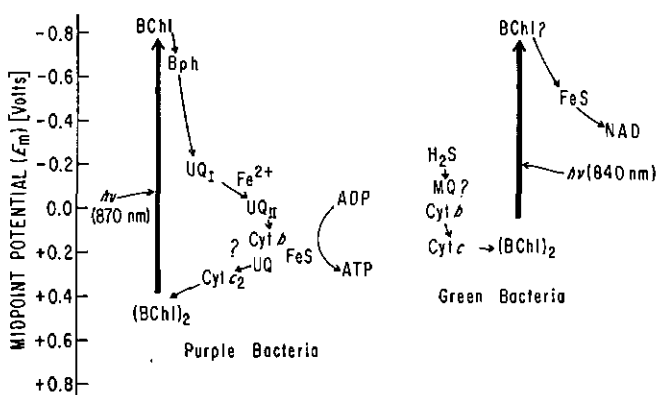

FIG. 3. Electron transfer components and their redox potentials in photosynthetic bacteria. See list of abbreviations.

which generates ATP (photophosphorylation). Purple bacteria are also capable of driving noncyclic electron transport using low potential donors, such as H_2S or succinate, to reduce a variety of acceptors, including NAD^+ and CO_2 . The low potentials required for NAD^+ reduction ($E_{m,7} = 0.32$ V) are apparently not generated directly but are generated by "reverse electron transport" requiring ATP (Knaff, 1978). The green bacteria, on the other hand, have a RC that has a low enough potential to reduce NAD^+ directly using H_2S as a donor (Knaff, 1978). Green bacteria apparently do not perform cyclic photophosphorylation producing ATP (Pierson and Castenholz, 1978). The electron transfer components of RC complexes in purple and green bacteria are shown in Fig. 3 (also see Fig. 1 in Wraight, Chapter 2, this volume).^{*} The readers should also consult Parson and Ke, Chapter 8, and Cramer and Crofts, Chapter 9, this volume.

A. Purple Bacteria

1. REACTION CENTER PREPARATIONS

Following the initial results of Reed and Clayton (1968) and Gingras and Jolchine (1969), RC preparations from a variety of photosynthetic bacteria have been obtained. These have been isolated by detergent solubilization and purified using standard techniques, such as gradient

^{*}(BChl)₂ ≡ P870 (purple); P840 (green); UQ_I ≡ Q_A; UQ_{II} ≡ Q_B.

TABLE I
 Representative Reaction Center Preparations from Bacteria and Green Plants

Organism	Name	Detergent	Chl(BChl)	Polypeptide MW ($\times 10^{-3}$) ^a	Cytochromes	Quinones	Fe	References
Bacteria								
<i>Rp. sphaeroides</i> R-26	LM	LDAO/SDS or LDAO/LiClO ₄	4 BChl <i>a</i> 2 Bph <i>a</i>	21, 24	None	~ 1 UQ	1 Fe ²⁺	Fehér and Okamura (1978) Okamura <i>et al.</i> (1974)
<i>Rp. sphaeroides</i> R-26	RC	LDAO	4 BChl <i>a</i> 2 Bph <i>a</i>	21, 24, 28	None	2 UQ	1 Fe ²⁺	Fehér and Okamura (1978)
<i>Rs. rubrum</i>	RC	LDAO	4 BChl <i>a</i> 2 Bph <i>a</i>	21, 24, 28	None	1 UQ	1 Fe	Noël <i>et al.</i> (1972)
<i>Chr. vinosum</i>	RC	Triton/acetone			2 Cyt <i>c</i> ₅₅₈ 2 Cyt <i>c</i> ₅₅₅	1 MQ	Present	Vadeboncoeur <i>et al.</i> (1979a) Tiede <i>et al.</i> (1976b)
<i>Rp. viridis</i>	RC	LDAO SDS	4 BChl <i>b</i> 2 Bph <i>b</i>	23, 29, 37, 45	Cyt <i>c</i> ₅₅₅ Cyt <i>c</i> ₅₅₈	1 MQ		Halsey and Byers (1975) Trosper <i>et al.</i> (1977) Pucheu <i>et al.</i> (1976)
Green plant PSI Swiss chard	P700 RC complex	Digitonin/ Triton/SDS	40 Chl <i>a</i>	70	None	None		Bengis and Nelson (1975)
<i>Phormidium</i> <i>luridum</i>	P700 Chl <i>a</i> protein	SDS	40 Chl <i>a</i> Ph	48 major 46 minor	None	Unidentified Quinone		Dietrich and Thornber (1971) Thornber <i>et al.</i> (1977)

Swiss chard	PSI RC complex	Digitonin/ Triton	100 Chl <i>a</i>	70, 25, 20, 18 16, 8	None	None	(4.6)	Bengis and Nelson (1975)
Several higher plants	P700 Chl <i>a</i> protein	Triton	40 Chl <i>a</i> No Ph No Chl <i>b</i> 35 Chl <i>a</i>	1 Cyt <i>f</i> 2 Cyt <i>b₆</i>	MQ No PQ	Present		Thorner <i>et al.</i> (1977) Shiozawa <i>et al.</i> (1974)
Spinach	TSFI HP700	Triton	35 Chl <i>a</i>	None	None			Vernon and Shaw (1971) Yamamoto and Vernon (1969) Ke <i>et al.</i> (1975)
Green plant PSII Spinach	PSII Chl <i>a</i> protein	Digitonin	~ 50 Chl <i>a</i>	43, 27, 6.5	Cyt <i>b₅₅₉</i>			Sato and Butler (1978) Sato (1979)
Spinach	TSFII _a	Triton	30-40 Chl <i>a</i>		Cyt <i>b₅₅₉</i>	PQ	~2	Vernon and Shaw (1971) Ke <i>et al.</i> (1975)
Spinach	(FII)	Digitonin	40-50 Chl <i>a</i>					Wessels <i>et al.</i> (1973) Wessels and Borchert (1978)

^aObtained from relative electrophoretic molarities by SDS-PAGE. Absolute values may be in error by as much as 30% (Rosen *et al.*, 1980).

centrifugation, $(\text{NH}_4)_2\text{SO}_4$ precipitation, DEAE chromatography, and gel filtration (see Gingras, 1978; Olson and Thornber, 1979; for reviews) (Table I). The best characterized of these preparations have been obtained from the blue-green carotenoidless mutant R-26 of *Rp. sphaeroides*, using the detergent LDAO (Clayton and Wang, 1971; Feher, 1971; Feher and Okamura, 1978). Similar preparations have been made from *Rs. rubrum* (Noël *et al.*, 1972; Okamura *et al.*, 1974; Vadeboncoeur *et al.*, 1979a), wild-type *Rp. sphaeroides* (Jolchine and Reiss-Husson, 1974), *Rp. capsulata* (Nieth *et al.*, 1975), and *Chr. vinosum* (L. C. Ackerson, unpublished results). In addition to these preparations, which lack cytochrome (Cyt) *c*, several preparations that contain Cyt *c* have been obtained [*Chr. vinosum* (Halsey and Byers, 1975; Lin and Thornber, 1975; Dutton *et al.*, 1977; Romijn and Amesz, 1977), *Rp. minutissimum* (Moskalenko and Erokhin, 1974), *Rp. viridis* (Pucheu *et al.*, 1976; Prince *et al.*, 1977; Trosper *et al.*, 1977; R. K. Clayton and Clayton, 1978), and *Rp. gelatinosa* (B. J. Clayton and Clayton, 1978)]. An interesting property of these RC preparations is that the Cyt is capable of reducing the oxidized primary donor at cryogenic temperatures (Dutton *et al.*, 1977). Other complexes, called *photoreceptor complexes*, which have been obtained from *Rs. rubrum* and *Rp. sphaeroides*, contain a functional antennae complex capable of transferring excitation energy to the RC (Loach, 1976). Most RC preparations exhibit the characteristic optical absorption spectra (see Fig. 4) with three maxima in the near IR at 870, 800, and 760 nm. Bacteriochlorophyll-*b* containing organisms, such as *Rp. viridis*, show spectra that are shifted to the IR with peaks at 960, 850, 830, 815, and 790 nm. All these preparations are photochemically active as shown

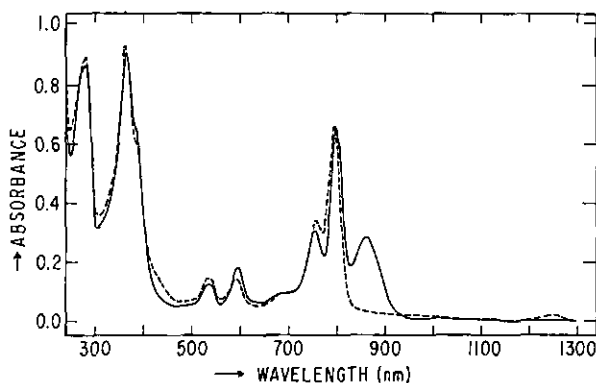

FIG. 4. Absorption spectrum of the RC preparation from *Rp. sphaeroides* R-26 in the dark (—) and with strong cross illumination (---). [Reprinted with permission from Feher, G. (1971). *Photochem. Photobiol.* 14, 373–387. Copyright 1971, Pergamon Press, Ltd.]

by the bleaching of the long wavelength absorption band under strong illumination (Fig. 4).

The purified RCs contain a number of cofactors important in the primary photochemistry: 4 BChl, 2 bacteriopheophytins (Bph), 1 carotenoid (Car) 1–2 quinones (Q), and one non-heme Fe^{2+} (see Table I). (See a generalized diagram: Fig. 2 in Kaplan and Arntzen, Chapter 3, this volume.) The function of these various components will be discussed later.

2. PROTEIN STRUCTURE

a. Subunit Structure. Purified bacterial RC preparations characteristically contain three polypeptide chains as shown by SDS–polyacrylamide gel electrophoresis (SDS–PAGE) (Feher, 1971; Clayton and Haselkorn, 1972) (Fig. 5a). The subunits labeled L, M, and H (for light, medium, and heavy) migrate with electrophoretic mobilities corresponding to proteins with MW of $\sim 21,000$, $24,000$, and $28,000$, respectively. Slight variations in the electrophoretic patterns have been observed among different bacterial species (Clayton and Haselkorn, 1972; Feher and Okamura, 1978). The values for the MWs obtained for RC proteins by SDS–PAGE must be considered to be only approximate since they were obtained from mobilities relative to those of water soluble proteins, which may have significantly different SDS-binding properties from membrane proteins. For a more detailed discussion, see Section II,A,2,d. When RC samples were heated at 100°C in SDS and 2-mercaptoethanol, Clayton and Haselkorn (1972) reported an absence of the L and M bands on SDS–PAGE gels. This effect was shown by Shepherd and Kaplan (1978) to be due to aggregation caused by β -mercaptoethanol. This loss of RC proteins due to aggregation after heating in SDS is also observed in RC proteins from PSI and PSII. The stoichiometry between the L, M, and H subunits for *Rp. sphaeroides* and *Rs. rubrum* has been shown by several different techniques to be 1 : 1 : 1 (Feher and Okamura, 1978; Vadeboncoeur *et al.*, 1979a).

Most isolated bacterial RC preparations contain the three subunits L, M, and H; one of these subunits, H, can be dissociated by treatment with a variety of solvents (Fig. 5b and c). The L–M complex from *Rp. sphaeroides* exhibits an absorption spectrum that is almost identical to the one obtained from RCs (i.e., L, M, and H units) (Okamura *et al.*, 1974). In some preparations from *Rs. rubrum* (Snozzi and Bachofen, 1979) and *Rp. sphaeroides* (Hall *et al.*, 1973; Broglie *et al.*, 1980), only two of the three subunits were observed. These may correspond to the L–M subunits from which the H subunits have been dissociated during purification.

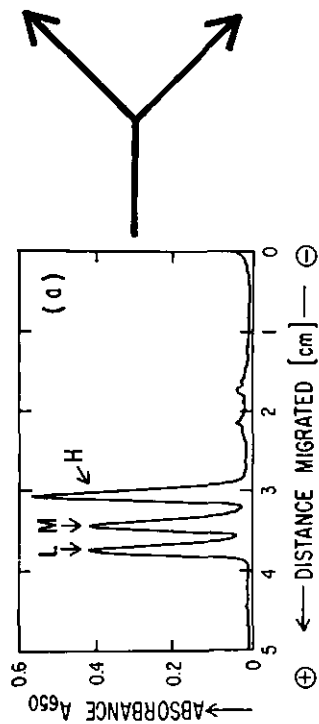
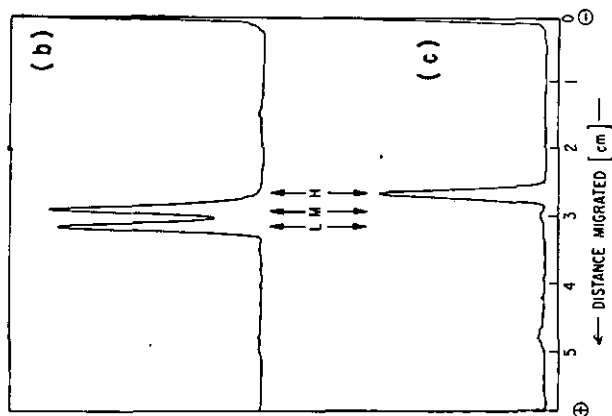

FIG. 5. SDS-PAGE scans of RCs from *Rp. sphaeroides* R-26. (a) Native RCs. (b) L-M (photochemically active) subunit. (c) H (inactive) subunit. The L-M and H subunits were separated by centrifugation in a sucrose gradient containing 1% SDS, 0.4% LDAO. L, light; M, medium; and H, heavy subunits. [Reprinted with permission from Okamura, M. Y., Steiner, L. A., and Fehet, G. (1974). *Biochem. J.* 13, 1394-1403. Copyright American Chemical Society, 1974.]

tion. The RC preparations from *Rp. viridis* (R. K. Clayton and Clayton, 1978) and *Rp. gelatinosa* (B. J. Clayton and Clayton, 1978) were found to have different subunit compositions than the other species of *Rhodospseudomonas*. The *Rp. viridis* subunits had MWs of 31,000, 37,000, and 47,000, and the *Rp. gelatinosa* subunits had MWs of 33,000 and 25,000.

The conditions initially used for dissociation of the L-M complex from RC of *Rp. sphaeroides* involved the use of SDS (1%) + LDAO (0.6%), which resulted in a complex that was photochemically active (bleachable by continuous illumination) at room temperature but was inactive at low temperature (Okamura *et al.*, 1973). The loss of activity at low temperature was most likely due to the removal of the primary acceptor. The bleaching at room temperature was probably caused by electron transfer to a diffusible exogenous acceptor (perhaps O₂). Although at the time of the initial experiments it was postulated that the inactivation was due to a loss of Fe (Okamura *et al.*, 1973), it is now believed to be due to a loss of ubiquinone (UQ) (Okamura *et al.*, 1975). Milder conditions for the dissociation of the L-M from the H subunit, utilizing the chaotropic agent LiClO₄ have been developed (Feher and Okamura, 1978; Rosen *et al.*, 1980a). The L-M subunit obtained by this treatment (<5% H) is active at low temperature and contains ~1 Fe/RC, and ~1 UQ/RC. It exhibits the broad light-induced ESR signal ($g = 1.8$) characteristic of the primary quinone acceptor (see Fig. 6). Thus, the L-M unit is the smallest unit capable of photochemistry in bacteria.

The L-M complex, upon illumination, reacts with reduced Cyt *c*, analogous to undissociated RCs (L, M., and H). However, it has an altered reactivity on the acceptor side, rapidly photoreducing an unknown acceptor species (perhaps detergent molecules) (D. Rosen, R. Debus, M. Okamura, and G. Feher, unpublished results). This may indicate that the removal of the H subunit exposes the low potential intermediate acceptor species I⁻ (see Section II, A, 3, b) which may reduce an exogenous acceptor without first reducing the endogenous ubiquinone.

The functional role of the various subunits has been investigated by labeling experiments. A radioactive photoaffinity label, 2-azidoanthraquinone, has been used to label specifically the primary quinone-binding site. This quinone, which reconstitutes photochemical activity in quinone-depleted RCs, was shown to label the M subunit (Marinetti *et al.*, 1979).

The M subunit has also been implicated as the binding site for the secondary quinone, Q_{II}, by antibody inhibition of Q_{II} photochemical activity. Antibodies against the M subunit were inhibitory, whereas those against L or H were not (Okamura *et al.*, 1982; Debus *et al.*, 1982).

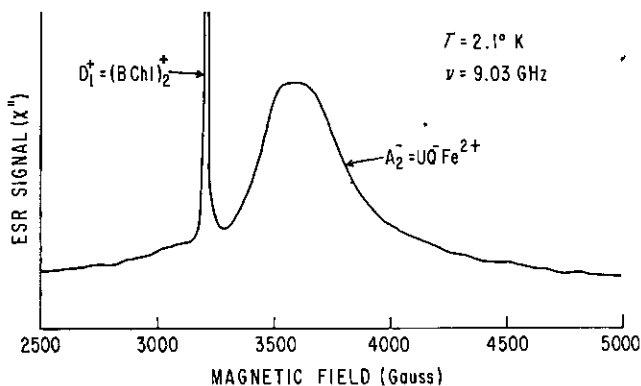

FIG. 6. Light-induced ESR signals from the L-M units from *Rp. sphaeroides* R-26 prepared with LiClO_4 (Feher and Okamura, 1978). The sample contained <0.05 H/RC (D. Rosen, M. Y. Okamura, and G. Feher, unpublished results).

Cytochrome *c* (horse) was chemically cross-linked to RCs, with the cleavable cross-linking agent dithiobispropionimidate. It was shown to cross-link to both the L and M subunits (Rosen, 1979; Rosen *et al.*, 1979), indicating that the Cyt binding site is close to (within 10 Å) both L and M. This conclusion was supported by experiments showing that the fast phase of Cyt *c* oxidation, which requires a RC-Cyt complex, was selectively inhibited by antibodies directed against L and M, but not H (Rosen, 1979). Similar results were obtained for Cyt c_2 .

b. Amino Acid Composition. The amino acid compositions of the RC and its isolated subunits have been determined for *Rp. sphaeroides* (Steiner *et al.*, 1974a; Rosen, 1979) and *Rs. rubrum* (Vadeboncoeur *et al.*, 1979a). Table II shows the amino acid composition for *Rp. sphaeroides* (L. A. Steiner, unpublished results). The composition of *Rs. rubrum* is very similar, as judged by the low compositional divergence [see Table V, Section V (Appendix)]. The most striking feature of the amino acid analysis is the low proportion of polar amino acid residues (29–40%). Most water soluble proteins contain about 50% of polar residues, which is consistent with the RC being an “integral membrane protein” (Singer and Nicolson, 1972). The L and M subunits are very nonpolar (hydrophobic) and show a considerable compositional homology. The H subunit is more polar than either L or M. This is consistent with H being more exposed on the exterior surface of the chromatophore as determined by a number of labeling experiments (Section II,A,2,e). The number of half cystines in both *Rp. sphaeroides* and *Rs. rubrum* is estimated to be 6. In RCs of *Rp. sphaeroides*, three half cystines are on the L

TABLE II
Amino Acid Composition of RCs and Their Subunits from *Rp. sphaeroides* R-26^a

Amino acid	Subunits (mole %)			RCs (mole %)
	L	M	H	LMH
Asp	5.98	6.67	8.20	6.91
Glu	4.33	6.07	8.60	6.70
Lys	2.01	1.30	5.08	2.69
His	2.3	2.1	2.08	2.38
Arg	2.76	3.84	4.31	3.83
Thr	5.51	4.70	4.84	4.83
Ser	4.32	5.97	4.72	4.94
Gly	11.38	11.18	9.65	10.95
Ala	10.05	10.55	10.90	10.43
Val	5.93	5.95	7.64	6.49
Ile	6.75	4.95	4.70	5.49
Leu	11.88	11.89	9.30	10.84
Pro	5.9 ^c	4.7 ^c	8.81	6.04
Met	1.60	3.1	3.15	2.62
½ Cys	1.3 ^c	0.0 ^c	0.88 ^c	0.71
Tyr	3.94	2.43	2.49	3.11
Phe	8.36	7.34	3.81	6.70
Try	5.7 ^c	7.3 ^c	0.85 ^c	4.32
Polar ^b	27.2	30.6	37.8	32.3
Best MW	28,000 ^d	32,000 ^d	36,000 ^e	95,000 ^f ± 5,000

^aThe data on individual subunits L, M, and H from Rosen (1979) and L. A. Steiner, D. Rosen, and G. Feher, unpublished results.

^bSum of (Asp + Asn), (Glu + Gln), Lys, His, Arg, Thr, Ser.

^cData from Sutton *et al.* (1981, 1982).

^dDetermined from the integral number of amino acid residues, which gave a best fit to the experimentally determined mole fractions (Rosen *et al.*, 1980a).

^eSee footnote in Section II.A,2,d.

^fFrom the amino acid content and extinction coefficient (Steiner *et al.*, 1974a).

subunit and three on the H subunits; the M subunit contains none (Steiner *et al.*, 1974a). The difference in cystine content has been used to isolate the L subunit from L-M by affinity chromatography (Rosen *et al.*, 1977).

c. Amino Acid Sequence. The N terminal amino acid sequences of the three RC subunits from *Rp. sphaeroides* have been determined (Rosen *et al.*, 1977; Sutton, *et al.*, 1981, 1982). They are as follows:

L: Ala-Leu-Leu-Ser-Phe-Glu-Arg-
 Lys-Tyr-Arg-Val-Pro-Gly-Gly-Thr-Leu-Val-Gly-
 Gly-Asn-Leu-Phe-Asp-Phe-His-Val.

M: Ala-Glu-Tyr-Gln-Asn-Ile-Phe-
 Ser-Gln-Val-Gln-Val-Arg-Gly-Pro-Ala-Asp-Leu-
 Gly-Met-Thr-Glu-Asp-Val-Asn-Leu-Ala-Asn.
 H: Met-Val-Gly-Val-Thr-Ala-
 Phe-Gly-Asn-Phe-Asp-Leu-Ala-Ser-Leu-
 Ala-Ile-Tyr-Ser-Phe-Trp-Ile-Phe-Leu-Ala-X-Leu-Ileu.

Four of the first 10 N-terminal residues of the L subunit are positively charged suggesting that this segment of the protein is at the membrane surface. Conversely, the N-terminal sequence of the H subunit is extremely hydrophobic suggesting that it lies in the interior.

d. Molecular Weight. The MW of the RC has been determined by a variety of methods. The simplest method, SDS-PAGE, gives values for the three subunits of $\sim 75,000$ for a variety of RC preparations (see Table I). This procedure is probably in error due to uncertainties in the amount of SDS binding to membrane proteins. Better estimates of the minimum MW of the individual subunits of RC from *Rp. sphaeroides* were obtained by an analysis of the amino acid composition (Rosen *et al.*, 1980a). By this method, the MWs of the L and M subunits were found to be 28,000 and 32,000, respectively. That of the H subunit is about 36,000.* The sums of these values compare well with the value of 95,000 obtained from the amino acid content (i.e., protein weight) (Steiner *et al.*, 1974a) and the extinction coefficient (Straley *et al.*, 1973), $\epsilon_{800} = 288 \times 10^3 \text{ cm } M^{-1}$. A similar analysis on *Rs. rubrum* RCs gave a minimum MW of 90,000 (Vadeboncoeur *et al.*, 1979a).

The MW of the isolated RC particle has also been estimated by physical chemical approaches such as gel filtration and sedimentation studies. Initial results on *Rp. sphaeroides* (Reiss-Husson and Jolchine, 1972) and *Rs. rubrum* (Noël *et al.*, 1972) indicated a MW of about 150,000. To reconcile this large value with the other determinations, one has to postulate that either RCs form a dimer or that a large amount of lipid or detergent is bound to them. Further studies have shown that RC preparations do bind a large amount of detergent: 0.58–0.67 g LDAO per gram of protein for *Rp. sphaeroides* (Rivas *et al.*, 1980) and, depending on salt concentration, between 1.0 and 2.3 g Triton per gram of protein for *Rs. rubrum* (Vadeboncoeur *et al.*, 1979b). Using these corrections, the MW of the RC protein from *Rp. sphaeroides* was estimated to be 84,000 in

*Some uncertainty still exists concerning the MW of the H subunit. The value of 36,000 was obtained from the MW of LM and the measured ratio of the amount of protein in LM and H (from Okamura *et al.*, 1974).

LDAO and 87,000 in Triton. This is close to the minimum MW of 95,000 obtained from the amino acid content. This shows that the RC complex in solution is a monomeric species (i.e., three subunits) (Rivas *et al.*, 1980). In contrast, the MW of the RC from *Rs. rubrum* in Triton X-100 was found to be close to 60,000. This unusual result was interpreted as being due to a dissociation of the L-M subunit from the H subunit under the conditions of the MW measurement (Vadeboncoeur *et al.*, 1979b).

e. Location of the Reaction Center in the Membrane. The topology of the RC in the membrane has been studied using the techniques of antibody binding, proteolysis, and protein labeling. Reed *et al.* (1975) treated chromatophores with ferritin-labeled antibodies prepared against RCs. The antibodies bound to the chromatophore surface indicating an exposed RC protein at the membrane surface. These studies have been extended by Steiner *et al.* (1974b), Valkirs *et al.* (1976), and Valkirs and Feher (1981, 1982), using antibodies that bind to the individual subunits L, M, and H and spheroplasts that are accessible to antibodies on both sides. The results show that antibodies against the M subunit react on both sides of the membrane (see Fig. 7). Antibodies against the H subunit readily labeled the outside surface of the chromatophore and in one case (out of six) labeled the inner membrane surface as well. Therefore, the M and H subunits span the membrane. Thus far, antibodies against the L subunit have labeled only the inner surface of the chromatophore.

Proteolysis experiments showed that the H subunit is extensively digested when chromatophores were treated with proteolytic enzymes (Hall *et al.*, 1978). However, neither L nor M was cleaved.

Labeling experiments with radioactive iodine (Zürer *et al.*, 1977) showed an extensive reaction with the H subunit, but only a small amount of labeling of L and M. Apparently, L and M subunits have a smaller fraction of exposed reactive tyrosine and histidine residues. Labeling studies using the hydrophobic marker (that penetrates the membrane), 5-iodonaphthyl-1-azide, showed L and M to be more heavily labeled than the larger H subunit. This indicates that H is in a more hydrophilic environment (Odermott *et al.*, 1980) and is consistent with its amino acid composition.

The general picture that emerges from these experiments is that a significant portion of the H subunit is exposed on the exterior of the chromatophore along with a smaller portion of the M subunit. At the inner surface of the chromatophore all three subunits are exposed at the

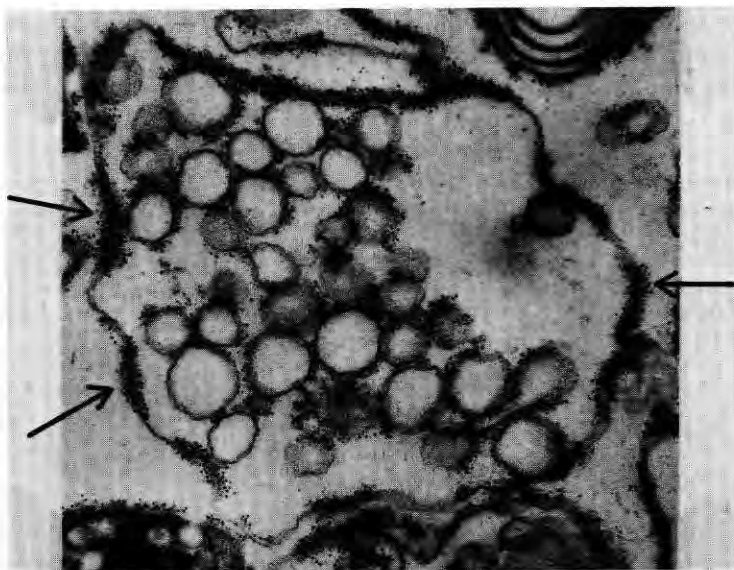

FIG. 7. Electron micrograph of spheroplasts from *Rp. sphaeroides* R-26 labeled with ferritin conjugated to antibodies against the M subunit. The labeling appears on both sides of the membrane (arrows) showing that M spans the membrane (G. Valkirs and G. Feher, 1982).

membrane surface. Two of them (L and M) appear to be close to the Cyt binding site (Rosen *et al.*, 1979; cf. Fig. 35, later).

It should be kept in mind that in these types of experiments a definitive conclusion can only be drawn from positive results. A negative result may be obtained if the site is not accessible to antibody, labeling reagent, or proteolytic enzyme.

f. Reconstitution of Reaction Centers into Membranes. Several types of experiments have been performed in which isolated bacterial RCs were added back into biological membranes. Garcia *et al.* (1974) reconstituted RCs from *Rp. capsulata* into membranes from a nonphotosynthetic mutant to restore photophosphorylation. Reaction centers have also been incorporated into phospholipid vesicles and light induced proton translocation has been observed (Crofts *et al.*, 1977; Darszon *et al.*, 1980). Reaction centers incorporated into phospholipid membranes have been studied by X-ray diffraction (Pachence *et al.*, 1979). Electrical measurements have been made on RCs in thick phospholipid films by Skulachev's group (Drachev *et al.*, 1976; Skulachev, 1979). The pho-

toelectric responses of RCs incorporated into well-characterized planar bilayer membranes have been investigated by Schönfeld *et al.* (1979) and Packham *et al.* (1980). All of these studies indicate that isolated RCs preserve their photochemical activity during the purification procedure.

3. NATURE OF THE PRIMARY REACTANTS

The photochemical process in bacterial RCs involves the light-induced electron transfer from the primary donor D_1 ($\equiv P$), called P870, to a series of acceptors (see Fig. 3; see also Parson and Ke, Chapter 8, and Cramer and Crofts, Chapter 9, this volume). The first acceptor, A_1 , called the intermediate or the initial acceptor (I) is reduced in < 10 psec. I^- then transfers its electron in ~ 200 psec (at 20°C) to the second acceptor, A_2 , which is the primary quinone, Q_1 ($\equiv Q_A$). Subsequent electron transfer occurs in ~ 100 μsec to a third acceptor, A_3 , which is a second quinone, Q_{II} ($\equiv Q_B$; see Chapter 8 by Parson and Ke for a detailed discussion of the kinetics). The chemical identification of the primary reactants, to be discussed next, was accomplished by a combination of spectroscopic and chemical techniques (see also Dutton *et al.*, 1977; Blankenship and Parson, 1979a; Sauer, 1979, for reviews).

a. Primary Donor—Bacteriochlorophyll Dimer. The oxidation of the primary donor is accompanied by changes in the optical absorption spectrum most prominently in the near IR region (Duysens, 1952) (see Fig. 8). The major change is a bleaching of the long wavelength band at 870 nm (960 nm in BChl *b* organisms) and a hyperchromic shift of the band near 800 nm (850 nm in BChl *b* organisms, i.e., *Rp. viridis*) (see Sauer, 1975). Changes at these wavelengths were observed in the circular dichroism (CD) spectrum of RCs and interpreted in terms of exciton splittings between at least three BChl molecules (Sauer *et al.*, 1968). The light-induced bleaching occurs in less than 10 psec (Netzel *et al.*, 1973; Moskowitz and Malley, 1978) with a quantum yield near unity (Wright and Clayton, 1974). The light-induced changes are reversible at cryogenic temperatures (Arnold and Clayton, 1960; McElroy *et al.*, 1974). These features are characteristic of primary photochemistry. Similar spectral change can also be obtained by chemical oxidation. By titrating the light induced changes the redox potential of the $P870^+/P870$ couple was determined to be 0.44 V (for a review, see Prince and Dutton, 1978a).

An examination of the band shift at 800 nm in RCs from *Rp. sphaeroides* oriented in stretched films or in oriented chromatophores (Vermiglio and Clayton, 1976) showed that it could be explained by a bleach-

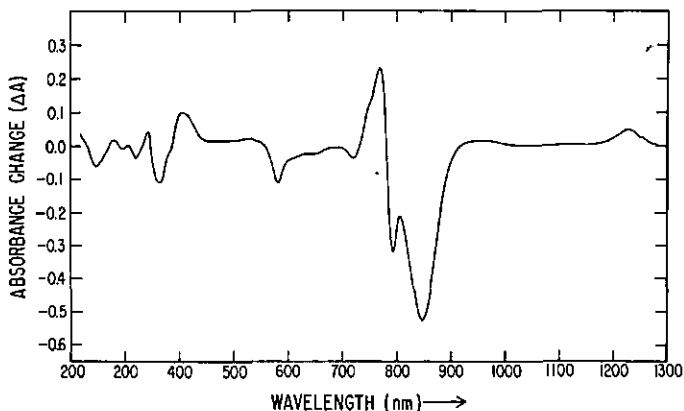

FIG. 8. Light-minus-dark optical difference spectrum of RCs from *Rp. sphaeroides* ($T = 20^{\circ}\text{C}$). The main changes are due to P+865-P865 (see also Fig. 4).

ing of a peak at 815 nm and the appearance of a new peak at 790 nm. Evidence for the peak at 815 nm was seen earlier in the better resolved second derivative spectra at 77°K . The peak was not observed in oxidized RCs (Feher, 1971). The peaks at 870 nm and 815 nm (or 960 nm and 850 nm in BChl *b* containing species) were interpreted as arising from an exciton splitting in the BChl dimer (Vermeglio and Clayton, 1976; Holten *et al.*, 1978). However, Shuvalov and Asadov (1979) advanced a different interpretation. They postulated that the short wavelength transition is due to a monomer whose absorption spectrum is altered when the dimer is oxidized.

The oxidation of D_1 (P870) is also accompanied by the appearance of a symmetrical Gaussian-shaped ESR signal at $g = 2.0026$ with a linewidth (peak-to-peak derivative) in *Rp. sphaeroides* R-26 of $\Delta H = 9.8$ Gauss (Sogo *et al.*, 1959; Bolton *et al.*, 1969; McElroy *et al.*, 1974) (Fig. 9). Although this g value is identical to that observed in the BChl cation radical, the linewidth is narrower by a factor of 1.4. In order to explain this result, Norris *et al.* (1971) proposed that in the oxidized donor, the unpaired electron is shared between a special pair of BChl molecules. This model predicts a narrowing of the ESR line by $\sqrt{2}$ (1.41). The dimer hypothesis was verified by ENDOR experiments which showed that the hyperfine interaction in the oxidized D_1 (P870) were one-half of those seen in BChl *in vitro* (Feher *et al.*, 1973, 1975; Norris *et al.*, 1973, 1975) (Fig. 10).

Further evidence for the dimer hypothesis comes from an analysis of

the triplet EPR spectrum, which is observed when the primary quinone acceptor, $A_2(=Q_1 \text{ or } Q_A)$, is reduced (Dutton *et al.*, 1972; Leigh and Dutton, 1974; Thurnauer *et al.*, 1975) or removed (Okamura *et al.*, 1975). The triplet spectrum is characterized by zero-field parameters, D and E , which depend on the average distance between the two unpaired spins of the triplet state. These parameters were found to be $\sim 20\%$ smaller for the triplet in the bacterial RC than for the BChl triplet *in vitro*. This reduction in the values of D and E is consistent with the BChl triplet being delocalized over two BChl molecules (Clarke *et al.*, 1977; Hoff, 1979).

Although the dimer hypothesis appears to account for the optical and ESR data for most bacterial donors, other interpretations have been advanced (see Pearlstein, Chapter 7, this volume). One puzzling observation is that in *Rp. viridis* the ratio of the linewidths of the monomer to that of the donor is 1.18 (Fajer *et al.*, 1977) instead of $\sqrt{2}$ (1.41) as expected from a symmetrical dimer. This discrepancy could be due to an inequivalence of the BChl molecules in the dimer, or a change in the electronic structure upon dimerization, or a decrease in the electron hopping rate. Davis *et al.* (1979a) investigated this problem using ENDOR spectroscopy and concluded that the ESR signal for the donor in *Rp. viridis* can be explained by a dimer in which the environment of the BChls is slightly altered. They emphasize that ESR linewidth data are not sufficient for a dimer–monomer assignment and that both ESR and ENDOR data are necessary.

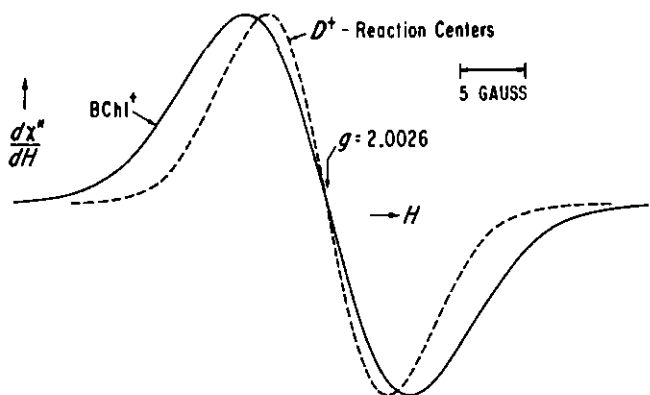

FIG. 9. Light-induced ESR signal (first derivative) from RCs from *Rp. sphaeroides* R-26 (dashed line) compared to oxidized (BChl⁺) (full line) ($T = 77^\circ\text{K}$, $\nu = 9 \text{ GHz}$). The linewidth of D^+ is narrowed by approximately $\sqrt{2}$ indicating that D^+ is a BChl dimer. (From Feher *et al.*, 1975. Reprinted with permission from the New York Academy of Sciences.)

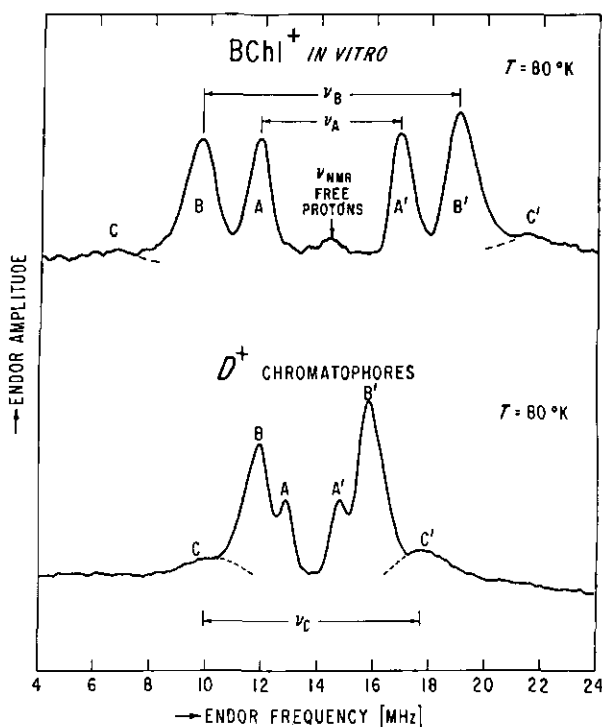

FIG. 10. Comparison of ENDOR spectra from $BChl\ a^+$ *in vitro* (top) and chromatophores of *Rp. sphaeroides* R-26 (bottom). All splittings in chromatophores (AA', BB', CC') are approximately one-half of the values obtained in the $BChl^+$ monomers. This is taken as proof of the dimer hypothesis. (From Feher *et al.*, 1975. Reprinted with permission from the New York Academy of Sciences.)

Resonance Raman experiments (Lutz and Kleo, 1979) have shown that the spectra of D^+ are similar to those obtained from the monomeric cation radical. These results do not seem, at first glance, to fit the dimer model. However, it should be kept in mind that the observed sharing of an electron between two molecules depends on the time scale of the observation with respect to an effective hopping rate of the electron. The Raman results can, therefore, be reconciled with the dimer model by assuming that the charge is localized on one molecule on the time scale of the Raman scattering experiment ($\sim 10^{-13}$ sec).

A number of detailed models have been proposed for the special $BChl$ pair (Fong, 1974; Boxer and Closs, 1976; Katz *et al.*, 1978; also see Pearlstein, Chapter 7, this volume).

b. Intermediate Acceptor—(Bacteriopheophytin). A transient acceptor species, A_1 (I for intermediate or initial acceptor), in bacterial

RCs was first suggested by the observation of a transient optical absorbance change after laser excitation in RCs, in which the primary quinone acceptor species, A_2 ($=Q_1$ or Q_A), was reduced (Fajer *et al.*, 1975; Parson *et al.*, 1975). This transient state, called P^F , was shown to be due to the rapid electron transfer from D_1 to A_1 . Since the electron hole recombination in $D_1^+A_1^-$ is rapid, observation of the transient oxidation of P870 requires high intensity laser flashes.

Fajer *et al.* (1975) proposed that I is Bph. This proposal was based on a comparison of the optical difference spectrum obtained from picosecond spectroscopy with the combined difference spectrum of the oxidized donor and reduced Bph (Fig. 11). The optical spectrum of I^- can also be obtained by trapping it. This is accomplished by illuminating RCs under reducing conditions in the presence of Cyt *c*. Under these conditions, the oxidized donor is reduced preventing charge recombination, i.e.,

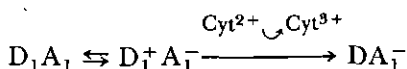

The optical difference spectrum ($I^- - 1$) of the trapped intermediate acceptor (see Fig. 12) has peaks, which are characteristic of Bph (decreases at 760 nm and 542 nm, a peak shift around 420 nm, and a small

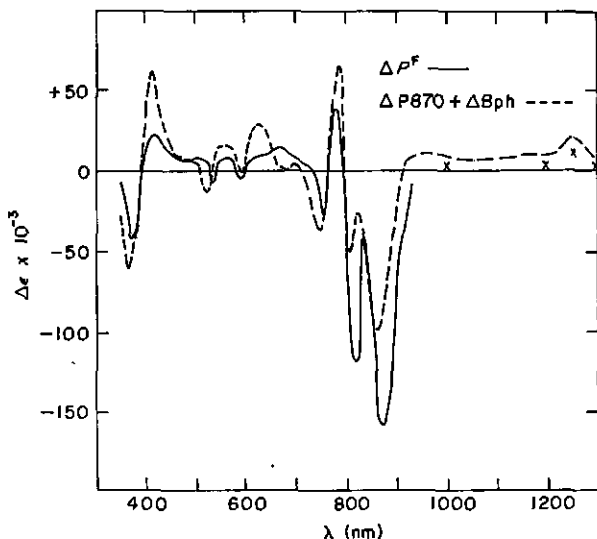

FIG. 11. Flash induced optical changes (light-minus-dark) due to state ΔP^F (solid line) observed in RCs from *Rp. sphaeroides* R-26. These changes are compared to the sum of the changes due to oxidation of P870 and reduction of Bph (dashed line). The similarity was used as evidence that the intermediate acceptor is Bph. (From Fajer *et al.*, 1975.)

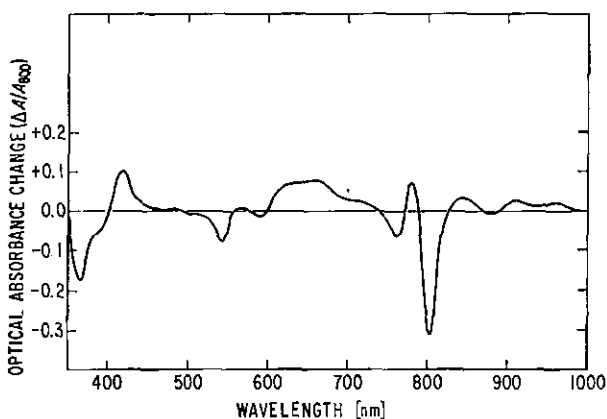

FIG. 12. Optical absorption changes (I^- -minus- I) due to photoreduction of the intermediate electron acceptor in RCs from *Rp. sphaeroides* R-26. (From Okamura *et al.*, 1979a.)

peak in the near IR at ~ 960 nm) (Shuvalov and Klimov, 1976; Tiede *et al.*, 1976b; van Grondelle *et al.*, 1976; Okamura *et al.*, 1979a). The peak in the difference spectrum at 543 nm corresponds to one of the two Bph peaks that is resolved in RCs at low temperature (Clayton and Yamamoto, 1976). The peak at shorter wavelengths due to the second Bph is not affected by photoreduction of A_1 . In addition to changes due to Bph, changes characteristic of BChl are also seen (decreases at 600 nm and 800 nm). These changes in BChl have been attributed to electric fields produced by the Bph anion at the site of the BChl (Shuvalov and Klimov, 1976; van Grondelle *et al.*, 1976). An alternate explanation involves a more direct involvement of BChl in the primary acceptor, i.e., the electron of I^- may be partially delocalized on BChl (for a detailed discussion, see Parson and Ke, Chapter 8, this volume). The midpoint potential for reduction of I in *Rp. viridis* (BChl *b*) was found to be -0.62 V at pH 11 (Klimov *et al.*, 1977b).

The ESR spectrum of the reduced intermediate acceptor I^- , formed by photoreduction at low redox potential, reveals a narrow Gaussian signal with $g = 2.0036$ and a linewidth of 12.9 G (see narrow signal of Fig. 13a) (Shuvalov and Klimov, 1976; Feher *et al.*, 1977). The linewidth is characteristic of a monomeric tetrapyrrole anion radical. Similarly, the ENDOR spectrum exhibits a major peak with splitting of ~ 8 MHz, which is characteristic of monomeric tetrapyrrole (Feher *et al.*, 1977). Unfortunately, the ESR and ENDOR spectra of the BChl and Bph anion radicals are too similar to each other to enable one to distinguish between them.

An interesting feature of the ESR spectrum of the reduced intermediate acceptor is a doublet splitting (Fig. 13b) of 60 G seen when RCs are illuminated at low redox potential and at low temperature. Since the doublet signal saturates at a higher microwave power than the singlet signal, it predominates at high power levels (Fig. 13b). This signal was first observed by Tiede *et al.* (1976a,b) in chromatophores of *Chr. vinosum* and has subsequently been observed in a variety of RC preparations (Prince *et al.*, 1977; Tiede *et al.*, 1977). Reaction centers from *Rp. sphaeroides* R-26, illuminated in the presence of Cyt *c*, displayed the doublet signal only if UQ was removed and replaced by menaquinone (MQ). (The primary acceptor of *Chr. vinosum* is MQ instead of UQ.) The doublet splitting is therefore believed to be due to a magnetic exchange interaction between A_1^- and A_2^- , where A_2^- is a MQ anion radical coupled to Fe^{2+} . The singlet signal is observed when A_2 is absent or when it is doubly reduced to a diamagnetic state (Okamura *et al.*, 1979a). The exchange interaction is due to an overlap of the electronic wavefunctions of the Bph and the quinone radicals; it is related to the distance between them as well as the electron transfer rate $I^-Q^- \rightarrow IQ^{2-}$ (Okamura *et al.*, 1979a).

Resonance Raman spectra of bacterial RCs illuminated in the Bph band ($\lambda = 528.7$ nm) have been obtained by Lutz *et al.* (1976). These spectra show structures (e.g., splittings of certain bands), that indicate a more complex environment of the Bph than that expected from mono-

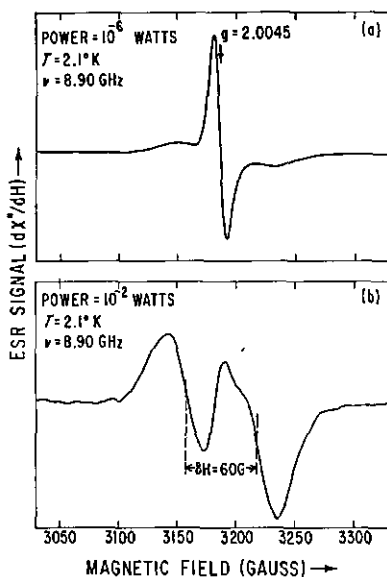

FIG. 13. ESR spectrum (first derivative) of the reduced intermediate acceptor in RCs from *Rp. sphaeroides* R-26 containing MQ taken at (a) low and (b) high microwave powers. The doublet signal observed at high power is due to an interaction between I^- and $Q^- Fe^{2+}$. Similar signals have been observed in PSII (see Figure 33). (From Okamura *et al.*, 1979a.)

meric Bph. This again points to the possibility that BChl (i.e., P800) is involved in the intermediate acceptor.

The question whether there is an intermediate acceptor that precedes I or whether I includes another carrier besides Bph has not been fully settled. Recent evidence has suggested that BChl may play a role as an early acceptor (Shuvalov and Asadov, 1979; Shuvalov and Parson, 1981; Wraight, Chapter 2; Parson and Ke, Chapter 8, this volume). An attractive feature of this hypothesis is that it would account for the presence of another BChl. It should be remembered that of the 4 BChl present in the RC only 2 have been definitively accounted for in the dimer of the primary donor. Similarly, of the 2 Bphs only 1 has been accounted for. It is therefore tempting to speculate that these "unaccounted for" tetrapyrrole pigments, often referred to as voyeur BChl or Bph, serve as very early acceptors and donors. Subpico-second spectroscopy, which is now being developed in several laboratories, should shed some light on this problem.

c. The Primary* Acceptor—Quinone. The reduced Bph acceptor transfers its electron in 200 psec to a so-called primary electron acceptor, A_2 (see Parson and Ke, Chapter 8; Cramer and Crofts, Chapter 9, this volume), also called Q_I or Q_A in this book. The $D_1^+A_2^-$ pair is relatively stable, having a recombination time at room temperature of ~ 100 msec. Thus, RCs with a functional primary acceptor can be photochemically bleached by continuous illumination with a tungsten lamp. The photochemical formation of $D_1^+A_2^-$ occurs reversibly even at cryogenic temperatures where the recombination time is about 30 msec (McElroy *et al.*, 1974). The $E_{m,7}$ for the primary acceptor in various bacteria varies from 0.02 V to -0.13 V (Prince and Dutton, 1978a).

The identification of the primary acceptor, A_2 , as a quinone molecule, came from ESR and optical spectroscopy. Loach and Hall (1972) showed that in *iron-free* RC preparations an ESR signal ($g = 2.004$, $\Delta H = 7.0$ G) was observed that could be distinguished from that of the oxidized donor due to the slight difference in g values (see Fig. 14 bottom trace). Subsequent ESR studies at several frequencies established the identity of the new radical as a ubiquinone anion radical, UQ^- (Feher *et al.*, 1972). ENDOR studies of the radical also support this assignment (Okamura *et al.*, 1980).

One puzzling feature of the narrow quinone ESR signal (Fig. 14, bottom trace) was that it could only be observed in iron-free RC prepara-

*Quinone was called the primary acceptor since it was the first one to be identified as the electron acceptor. Now, it is rationalized as "primary" because it is the first stable acceptor (see Section II,A).

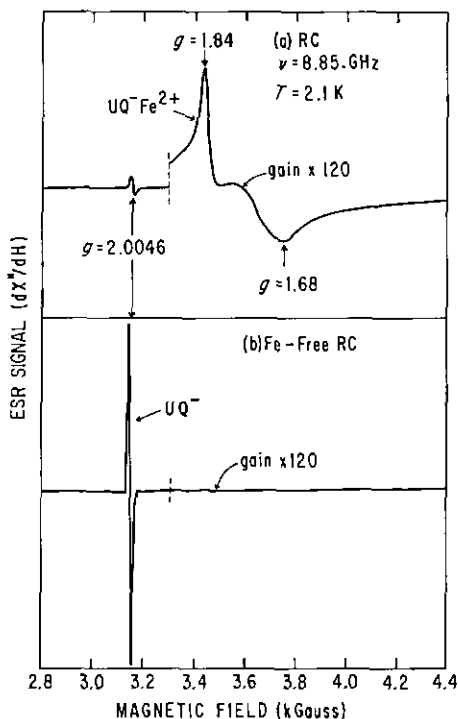

FIG. 14. ESR spectra (first derivative) of the primary acceptor species in (top) RCs, and (bottom) FE-free LM from *Rp. sphaeroides* R-26. The samples were reduced with dithionite. The presence of Fe^{2+} causes a large shift and broadening of the ESR spectrum of the primary acceptor.

tions (Feher *et al.*, 1972; Loach and Hall, 1972). In intact RCs containing 1 Fe/RC a broad ESR signal, $g = 1.8$, $\Delta H = 500$ G, was first observed by McElroy *et al.* (1970) using a light-modulation technique (*e.g.*, see Fig. 6), and subsequently by Leigh and Dutton (1972) and Dutton *et al.* (1973) using conventional magnetic field modulation (see Fig. 14, top trace). The existence of a broad ESR signal had been previously predicted by Bolton *et al.* (1969) to explain the absence of an observable acceptor signal. The apparent discrepancy between the ESR observations in RCs with and without Fe can be resolved by proposing a quinone-Fe complex in which the unpaired electron resides mostly on the quinone but interacts magnetically with the Fe (see Section II,A,3,e).

The optical changes due to the reduction of the primary acceptor A_2 are generally obscured by the large optical changes due to the formation of D_1^+ . However, in the presence of an exogenous donor that reduces D_1^+ , and orthophenanthroline that prevents electron transfer from A_2 to A_3 , the state $D_2A_2^-$ can be observed. The optical changes ($A_2^- - A_2$) obtained under these conditions reveal an absorption increase at 450 nm (Vermeiglio, 1977; Wraight, 1977) characteristic of the formation of a UQ^-

(Bensasson and Land, 1973) (see Fig. 15a). Similar changes were seen earlier under slightly different conditions (Clayton and Straley, 1970; Slooten, 1972). In addition to the absorbance increase at 450 nm, a shift of the Bph peak at 760 nm was observed (see Fig. 15a). This shift has been interpreted as being due to an electrochromic interaction between the reduced quinone and Bph.

Conclusive evidence that UQ serves as the primary acceptor in *Rp*.

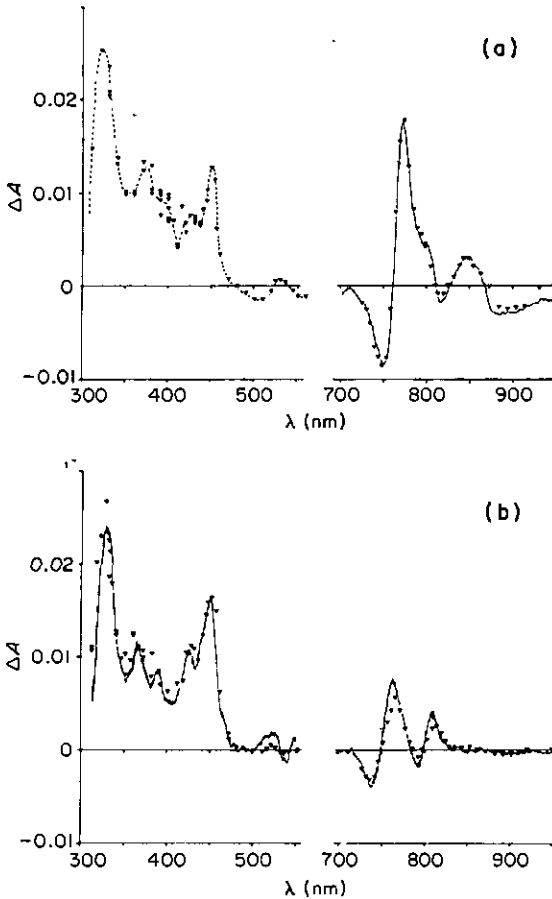

FIG. 15. Optical absorption changes due to photoreduction of the (a) primary quinone ($Q_I^- - Q_I$) and (b) secondary quinone ($Q_{II}^- - Q_{II}$). Triangles indicate results from flash excitation, solid lines are from continuous illumination. The absorption increases at 320 nm and 450 nm are characteristic of UQ^- . The changes in the IR region are attributed to "electrochromic" shifts of the spectrum of a nearby Bph molecule. (From Vermeglio and Clayton, 1977.)

sphaeroides RCs came from extraction and reconstitution experiments. Cogdell *et al.* (1974) showed that RCs, extracted with hexane and containing a small amount (0.1%) of methanol, lost the capacity for light-induced bleaching. Readdition of quinone restored this activity. Okamura *et al.* (1975) subsequently found that a combination of high LDAO concentration and orthophenanthroline removed UQ and led to a loss of photochemical activity that could be restored using UQ or a number of other quinones. Reaction centers reconstituted with different quinones exhibited changes in the dark recombination rate $D_1^+A_2^- \rightarrow D_1A_2$, as well as in the linewidth of the broad ESR signal. A quantitative study of the quinone content and photochemical activity showed that RCs from *Rp. sphaeroides* bound two quinones per RC; one tightly and one loosely bound quinone. The loss of photochemical activity was related to a loss of the tightly bound quinone. It was proposed that the loosely bound quinone serves as the secondary electron acceptor. Dutton *et al.* (1977) using the UQ extraction procedure of Okamura *et al.* (1975) monitored the lifetime of the $D_1^+A_1^-$ state by picosecond spectroscopy. They found that removal of quinone greatly increased the lifetime of this state by preventing the transfer to A_2 . Readdition of quinone reduced the lifetime of $D_1^+A_1^-$ by permitting this transfer to occur. These results provided additional evidence that UQ is the acceptor species A_2 .

Reaction centers from *Rs. rubrum* have been shown to bind ~ 1 UQ/RC (Vadeboncoeur *et al.*, 1979a), although Morrison *et al.* (1977) reported that in chromatophores of *Rs. rubrum* full photochemical activity is obtained with 0.5 UQ/P870. The origin of the discrepancy between these two findings is at present not understood. Menaquinone was found to be the primary quinone in *Chr. vinosum* (Okamura *et al.*, 1976; Feher and Okamura, 1977; Romijn and Amesz, 1977), and in *Rp. viridis* (Pucheu *et al.*, 1976).

d. The Secondary Acceptor—Quinone. The primary electron acceptor (A_2) transfers its electron in ~ 100 μ sec ($T = 20^\circ\text{C}$) to a secondary acceptor (A_3) (see Parson, 1978), also called Q_{II} or Q_B in this book. The rate of this reaction was measured using either a double flash method (Parson, 1969) or by monitoring optical absorbance changes (Vermeglio and Clayton, 1977; Wraight, 1979). The secondary acceptor was also identified as UQ using extraction and reconstitution procedures as described in the previous section. Extraction of UQ from *Chr. vinosum* chromatophores eliminated the electron transfer from the primary quinone acceptor A_2 (menaquinone). This activity could be restored by the addition of UQ, as well as by a number of other quinones (Halsey and Parson, 1974).

The optical spectrum due to the one electron reduction of the secondary acceptor was obtained by flash illumination of RCs from *Rp. sphaeroides* in the presence of exogenous donors that re-reduce D_1^+ (Vermeglio, 1977; Wraight, 1977). The optical difference spectrum ($Q_{II}^- - Q_{II}$) obtained after one flash shows a peak at 450 nm, characteristic of the formation of UQ^- (see Fig. 15b). In addition, shifts of the bands in the near IR were observed, which are similar but not identical to those observed for Q_I (compare Fig. 15a and 15b). This difference in electrochromic shifts at 770 nm between $Q_I^- - Q_{II}$ and $Q_I - Q_{II}^-$ was used to measure the rate of the electron transfer reaction (Vermeglio and Clayton, 1977; Wraight, 1979). The secondary quinone in contrast to the primary quinone can be doubly reduced to the hydroquinone. If RCs are given a series of saturating flashes in close succession, the absorbance at 450 nm first increases due to the formation of UQ^- ; then decreases on the second flash due to the formation of hydroquinone. If excess quinone is present in solution, the absorbance at 450 nm oscillates with successive flashes, showing a periodicity of two (Vermeglio, 1977; Wraight, 1977). This behavior is similar to that observed in PSII (see Section III,B,3,d and Cramer and Crofts, Chapter 9, this volume) and indicates the operation of a "two-electron gate."

The observation that each RC binds two quinones showed that the secondary acceptor was bound at a specific site on the RC rather than being free in the membrane. This was borne out by ESR measurements (Wraight, 1977, 1978; Okamura *et al.*, 1978). Reaction centers from *Rp. sphaeroides* containing two quinones were given saturating laser flashes in the presence of an exogenous donor. After the first flash a broad ESR signal ($g = 1.8$, $\Delta H = 450$ G), due to the state $Q_I Fe^{2+} - Q_{II}^-$, was observed (see Fig. 16). After two flashes, the broad ESR signal disappeared due to the formation of the diamagnetic $Q_I Fe^{2+} - Q_{II}^{2-}$ state. The third flash elicited an ESR signal similar to the first but with a different linewidth ($\Delta H = 350$ G) due to the state $Q_I^- Fe^{2+} - Q_{II}^{2-}$. The latter signal was identical to the one produced by reduction with dithionite. The ESR signals due to $Q_I^- Fe^{2+}$ and $Q_{II}^- Fe^{2+}$ show that both quinones are magnetically coupled to the Fe with approximately equal strength. Rutherford and Evans (1980) have studied the formation of the $Q_{II}^- Fe^{2+}$ ESR signal by chemical reduction. The signal at $g = 1.82$ forms at a midpoint potential E_m (pH 8) of 0.04 V (for *Rp. sphaeroides*); it decreases at lower potential due to formation of either the ESR silent state $Q_{II}^{2-} - Fe^{2+}$ or the $Q_I^- Fe^{2+} - Q_{II}^-$ state. Reaction centers in the $Q_I^- Fe^{2+} - Q_{II}^-$ state were prepared by freezing them after one flash and illuminating them at low temperature (Wraight, 1978; M. Okamura, R. A. Isaacson, and G. Feher, unpublished results). The illumination caused a decrease in the

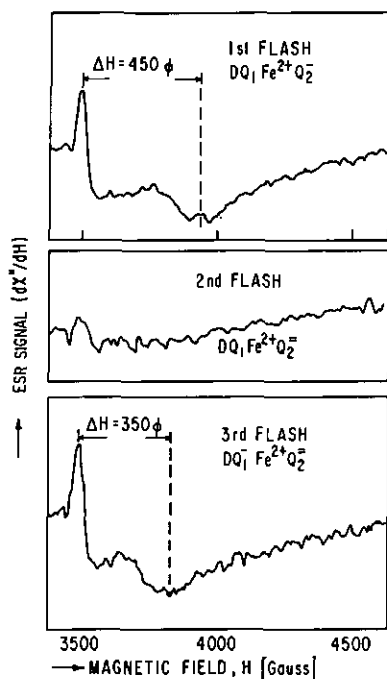

FIG. 16. ESR signals (first derivative) of reduced quinone-iron acceptors of RC of *Rp. sphaeroides* R-26 after 1, 2, or 3 laser flashes at room temperature in the presence of reduced Cyt c. $T = 2.1$ K, $\nu = 9.04$ GHz. The broad ESR signals seen after the first and third flashes are due to $Q_{II}Fe^{2+}$ and $Q_I^-Fe^{2+}$, respectively. After the second flash the nonparamagnetic state $DQ_I Fe^{2+} + Q_{II}^-$ is formed. (From Okamura *et al.*, 1978.)

signal due to Q_{II}^- . This was attributed to a strong magnetic interaction between Q_I^- and Q_{II}^- .

e. The Non-Heme Iron. The presence of Fe in RCs and the observation of the broad $g = 1.82$ ESR signal led initially to the hypothesis that Fe was the primary acceptor (Feher, 1971). However, several subsequent and independent experiments showed that Fe by itself cannot be the primary acceptor. These include (1) the observation that Fe can be removed or replaced by Mn without altering the primary photochemical activity, in particular the rate of donor-acceptor recombination ($D^+ A^- \rightarrow DA$) (Loach and Hall, 1972; Feher *et al.*, 1974; Loach *et al.*, 1975); (2) Mössbauer (Debrunner *et al.*, 1975) and magnetic susceptibility (Butler *et al.*, 1980) studies indicating that Fe is in the Fe^{2+} state and does not change valence when the acceptor is reduced.

Since Fe is closely associated with both quinones, it was proposed that the role of Fe is to facilitate electron transfer from the primary to the secondary quinone (the "Fe wire" hypothesis) (Okamura *et al.*, 1975). Consistent with this hypothesis, Blankenship and Parson (1979) observed that in RCs that were treated to remove Fe, the ability to transfer an electron from the primary to the secondary quinone correlated with

the amount of Fe/RC. However, the conditions for Fe removal are the same as those for the dissociation of the H subunit from the RC (Debus *et al.*, 1981). Thus, it is not clear whether loss of electron transfer from Q_I to Q_{II} results from Fe removal or subunit dissociation.

Iron has also been implicated in the mechanism by which several inhibitors are able to abolish the electron transfer from the primary to the secondary quinone (Parson, 1978). These include *o*-phenanthroline, and several hydroxyquinolines containing a hydrophobic side chain. The fact that orthophenanthroline can form Fe complexes suggested that the mechanism for its action involves the chelation of the Fe in RCs with a possible concomitant displacement of bound quinones. However, recent EXAFS (Extended X-ray fine structure spectroscopy) studies have shown that *o*-phenanthroline does not appreciably change the environment around the Fe (Eisenberger *et al.*, 1979, 1980, 1982; Bunker *et al.*, 1982; Stern *et al.*, 1979). The simplest explanation of these findings is that *o*-phenanthroline does not bind directly to Fe^{2+} . It remains to be shown whether *o*-phenanthroline inhibits the electron transfer from Q_I^- to Q_{II} in iron-free RCs.

The spin state of Fe in RCs is $S = 2$. Magnetic susceptibility measurements have shown that it can be described by a spin Hamiltonian (\mathcal{H}) (Butler *et al.*, 1980)

$$\mathcal{H} = g\beta\mathbf{H}\cdot\mathbf{S} + D[S_z^2 - \frac{1}{3}S(S+1)] - E[S_x^2 - S_y^2]$$

where β is the Bohr magneton, g is the electronic g value of Fe^{2+} , \mathbf{H} is the magnetic field, and D and E are crystal field parameters that were determined from the magnetization measurements at low temperatures.

For RCs containing one quinone, the values of the crystal field parameters were determined to be $D = 5.28$, $E = 1.33 \text{ cm}^{-1}$. These parameters did not change appreciably in RCs containing two quinones. This suggests that neither quinone forms a direct ligand with iron. The magnetic susceptibility of the reduced acceptor $Q_I^- Fe^{2+}$ was accounted for by assuming a small magnetic exchange interaction ($|J| < 1 \text{ cm}^{-1}$) between Fe^{2+} and Q_I^- . This is again consistent with Q_I being nearby but not coordinated to the Fe.

Extended X-ray fine structure spectroscopy (EXAFS) of Fe in RCs has been studied in RCs having various numbers of quinones, both in the presence and absence of *o*-phenanthroline (Eisenberger *et al.*, 1979, 1980, 1982; Bunker *et al.*, 1982; Stern *et al.*, 1979). Extended X-ray fine structure spectroscopy is sensitive to the nature of the coordination to Fe (i.e., the number and type of ligands and their distances). Reaction centers with one and two bound quinones exhibited the same EXAFS spectra. Similarly, no change in the EXAFS spectrum was observed when excess *o*-phenanthroline was added to RCs. These findings provide addi-

tional evidence that Fe does not directly coordinate to the secondary quinone or to *o*-phenanthroline. A change in the amplitude of the EXAFS spectra was observed when the primary quinone was removed (Eisenberger *et al.*, 1980). This is most likely due to a conformation change produced by the removal of Q_1 , although the removal of a coordinated quinone from the Fe cannot be excluded.

Mössbauer measurements of ^{57}Fe in RCs from *R. sphaeroides* were performed on samples containing one or two UQ molecules, as well as on samples containing *o*-phenanthroline (Boso *et al.*, 1981). All samples showed a single quadrupole doublet with similar splitting, center shifts, and temperature dependence. These results indicate that neither quinone (Q_1 nor Q_{11}) nor *o*-phenanthroline is in the first coordination sphere of the Fe.

f. Cytochromes. Although most bacterial RCs can be obtained free of Cyt c_2 , there are several species of bacteria that apparently have a membrane-bound Cyt closely associated with the RC (Bartsch, 1978). These include *Rp. viridis* and *Chr. vinosum*. Reaction center preparations from *Chr. vinosum* have been obtained with four bound functional Cyts (Tiede *et al.*, 1976b; Dutton *et al.*, 1977), two of these are high potential Cyt $c_{555}[E_{m,7} = 0.34 \text{ V}]$ and two low potential Cyt $c_{553}[E_{m,7} = 0.01 \text{ V}]$. The low potential Cyt is capable of transferring electrons to the oxidized donor at cryogenic temperatures (DeVault and Chance, 1966; Dutton and Prince, 1978). This is in contrast to Cyt c_2 which, when bound to RCs of *Rp. sphaeroides*, cannot transfer an electron at cryogenic temperatures.

In *Rp. sphaeroides*, the primary donor is reduced at 4°C in $\sim 1 \mu\text{sec}$ by a soluble Cyt c_2 , which binds tightly to the RC. The binding constant, K_D of Cyt c_2 , has been studied by kinetic (Overfield *et al.*, 1979; Rosen *et al.*, 1979) and equilibrium dialysis techniques (Rosen *et al.*, 1979, 1980b). At 4°C, K_D was found to be $\sim 1 \mu\text{M}$. Equilibrium dialysis results showed that only one Cyt c_2 is bound per RC (Rosen *et al.*, 1979, 1980b). The location of the Cyt binding site has been determined by chemical cross-linking and antibody inhibition to be close to the L and M subunits (Rosen *et al.*, 1979; Rosen *et al.*, 1982). Prince *et al.* (1975) have shown that antibodies against Cyt c_2 do not inhibit Cyt photo-oxidation in intact chromatophores, indicating that the Cyt c_2 binding site is on the interior of the chromatophore. (For further involvement of Cyts in photosynthesis, see Cramer and Crofts, Chapter 9, this volume.)

g. Carotenoids. Reaction centers prepared from wild-type *Rs. rubrum* (van der Rest and Gingras, 1974) and *Rp. sphaeroides* (Cogdell *et al.*, 1976) contain one bound Car. In addition, RCs from Car-free mutants have been reconstituted by adding exogenous Car (Boucher *et al.*, 1977; Agalidis *et al.*, 1980). Evidence from CD spectra indicates that the

bound Car is in the mono-cis state (Boucher *et al.*, 1977). However, resonance Raman and optical spectra have been interpreted to be due to a di-cis conformation (Lutz *et al.*, 1978; Agalidis *et al.*, 1980). It is interesting that the thermodynamically stable form of free Car is the all-trans configuration. Evidently, the steric constraints for Car binding to RCs cause severe distortion to the polyene chain.

Bound Car are believed to protect RCs from photochemical damage. Boucher *et al.* (1977) have shown that the aerobic photodestruction of isolated RCs occurs much more slowly when they contain carotenoid. These results may explain the observation that wild-type photosynthetic bacteria can grow in the presence of light and oxygen, whereas Car-less mutants are killed under these conditions (Sistrom *et al.*, 1956). A possible mechanism of the protective action of Car was suggested by the experiments of Cogdell *et al.* (1976), who found that the Car quenches the triplet state of BChl in RCs.

B. Green Bacteria

1. REACTION CENTER PREPARATIONS

Evidence for the existence of a P840 pigment presumably associated with the RC in green bacteria was provided by Sybesma and Vredenberg (1963). However, pure RC preparations from green bacteria have so far not been obtained. Membrane fragments from *Chlorobium limicola* enriched with RCs have been isolated (Olson *et al.*, 1977; Olson and Thornber, 1979). The smallest RC complex (complex II) contained about 40 BChl/RC, and had a peak in the absorption spectrum at about 810 nm and a shoulder at about 835 nm. Illumination resulted in the bleaching of two bands at 842 nm and 830 nm and the appearance of a peak at 1157 nm. The complex contained three or four Cyt *c*, one Cyt *b*, and one Car. Two Cyt c_{553} were found to be capable of transferring electrons to the RC. The RC from the green bacterium *Chloroflexus aurantiacus* has recently been isolated (Pierson and Thornber, 1982).

2. SUBUNIT COMPOSITION

The RC preparation from green bacteria contained six subunits with estimated masses from SDS-PAGE of 42, 36, 31, 23, 21, and 18 kD. The 31- and 21-kD subunits are thought to be associated with the RC (Olson and Thornber, 1979).

3. NATURE OF THE PRIMARY REACTANTS

a. Primary Donor—P840. Photooxidation of the donor resulted in bleaching of two bands at 842 nm and 830 nm and the formation of a

band at 1157 nm, suggesting a BChl dimer. The redox potential of the primary donor has been measured to be 0.25 V (Olson *et al.*, 1977) (somewhat lower than the one in purple bacteria). The ESR spectra of this donor gave a g value of 2.003 and a linewidth of 9.2 G (Olson *et al.*, 1977). These values are similar to those obtained for the dimer in purple bacteria.

b. Intermediate Acceptor. At the time of the writing of this chapter no intermediate acceptor species had been identified in green bacteria. Olson *et al.* (1977) reported that the RC preparations from *Chlorobium limicola* contain Bph. However, in analogy to PSI (see Section III,A,3,b), the intermediate acceptor may be BChl. It has a lower redox potential than Bph (Fajer *et al.*, 1975), which makes it a more likely candidate for an acceptor in green bacteria.

c. Primary Acceptor. The primary acceptor species in *Chlorobium* has a redox potential of -0.54 V (Olson *et al.*, 1977). This is similar to the potentials observed for the primary acceptor species in green plants. The acceptor has been associated with an Fe-S type ESR signal at $g = 1.94$, which appears at the same E_m (-0.5 V) (Knaff and Malkin, 1976). It can be photoreduced at low temperature (Jennings and Evans, 1976).

III. Green Plant Photosystems

The net result of photosynthesis in chloroplast containing organisms (higher plants and algae) is the formation of stable, reduced, and oxidized substrates, i.e., carbohydrates and molecular oxygen. To accomplish this, these organisms have developed a photosynthetic apparatus that is more complex than in bacteria. It is composed of two photosystems: PSII, which oxidizes water to O_2 , and PSI, which reduces $NADP^+$ to NADPH. These two photosystems are linked in series by an electron transfer chain between the acceptor side of PSII and the donor side of PSI. This is the so-called Hill and Bendall (or the Z) scheme of photosynthesis. For an early description of the experiments that led to this scheme, see Govindjee and Govindjee (1975). Electron transfer along this chain is capable of producing ATP (see Fig. 17; cf. with Fig. 1 in Wraight, Chapter 2, this volume).*

Each of the photosystems has a RC associated with it. As we mentioned in Section I,A, a RC is defined as a minimum unit that can

*In PSII (Chl) \equiv P680, in PSI (Chl) \equiv P700. Both primary donors are Chl species; however, their exact nature is not known. PQs \equiv Q_L , Q_H , B, and U in Chapter 2.

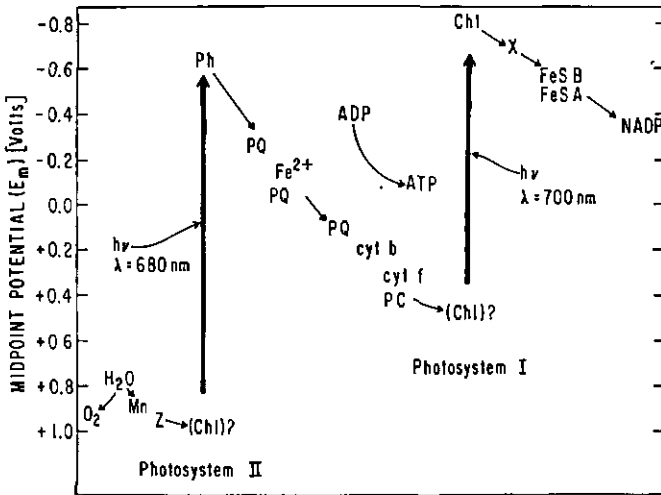

FIG. 17. Electron transfer components and their redox potentials in photosynthetic systems of green plants (cf. Fig. 1 in Wraight, Chapter 2, this volume). The primary donor species in both PSI and PSII are Chl species. The question marks indicate that their exact nature is not known. See footnote on p. 229.

perform a well-defined photochemical reaction. Two types of RC complexes have been defined in green plants (see, e.g., Nelson and Bengis, 1975). The first type are functional in the ultimate photochemical reactions, i.e., the photoreduction of NADP in PSI and the photo-oxidation of water in PSII. These RC-containing preparations are called the PSI RC complex and PSII RC complex. The second type can only perform the primary event of charge separation. These have been designated as P700-RCs and P680-RCs. P700 was discovered by B. Kok, to whom this volume is dedicated, and P680 by G. Döring in H. T. Witt's laboratory.

Several reviews have been published on the photochemical activity of chloroplast membranes and RCs (Avron, 1967; Boardman, 1968; Ke, 1973, 1978; Boardman *et al.*, 1978; Olson and Thornber, 1979). In this section we shall discuss studies that were conducted on purified RC complexes. Pure RCs devoid of antennae Chl have not yet been isolated from green plants.

A. Photosystem I

1. REACTION CENTER PREPARATIONS

A variety of RC preparations from PSI have been obtained (see Table I, pp. 202–203). They all show light-induced photo-oxidation of the primary donor, D_1 , called P700. The early steps towards the purification

of RC complexes from chloroplasts were performed by Boardman and Anderson (1964), Anderson and Boardman (1966), Vernon *et al.* (1966), Wessels (1966), and Briantais (1969). In their procedures physical separation between PSI and PSII was obtained by treatment with detergent. These studies aimed primarily at decreasing the amount of Chl bound to the RC. Consequently, the question of protein structure was frequently neglected.

Vernon and co-workers isolated a PSI RC particle (called TSF-1) from spinach using Triton X-100 and centrifugation (Vernon and Shaw, 1971). It contained 60 Chl *a*/P700. A particle with a lower ratio, ~30 Chl *a*/P700 (called HP700), could be obtained after removing Car by solvent extraction prior to detergent treatment (Ogawa and Vernon, 1969; Yamamoto and Vernon, 1969). Ke *et al.* (1975) reported an improved preparation (TSF-1a), which lacks Cyt *f* and *b*₆ and has 36 Chl *a*/P700. Reaction center preparations with 10–15 Chl *a*/P700 have also been reported (see, e.g., Ikegami and Katoh, 1975; Vacek *et al.*, 1977); but, again the question of the protein structure was neglected.

Thornber and co-workers reported on a number of different preparations of PSI RC complexes from a variety of organisms from blue-green algae to higher plants. The initial preparations were obtained using SDS and polyacrylamide gel electrophoresis or hydroxyapatite chromatography (Thornber, 1969; Dietrich and Thornber, 1971). Later, more stable preparations were obtained using Triton X-100 and hydroxyapatite chromatography (Shiozawa *et al.*, 1974; Thornber *et al.*, 1977). Such preparations (called P700–Chl *a*–protein) have been obtained from many chloroplast containing organisms (Thornber, 1975). They contain ~40 Chl *a*/P700 and lack Ph and Chl-*b* (Thornber *et al.*, 1977). The SDS preparations lack Cyt, whereas the Triton preparations contain Cyt *f* and *b*₆. The intact P700 Chl *a*–protein complex was reported to have a MW of 110,000 as estimated by SDS–PAGE. Since the protein was not totally denatured, the actual MW was estimated to be somewhat higher (Thornber, 1975).

A model based on the data from the P700–Chl *a*–protein isolated with SDS from *Phormidium luridum* has been proposed. In this model, P700 is located on a 46 kD subunit, which is associated with two Chl *a*-containing 48 kD subunits. An additional inactive Chl *a* containing unit, a trimer of 48 kD subunits, has been postulated to be present in the preparation (Thornber *et al.*, 1977).

A different approach of isolating purified RC complexes was taken by Bengis and Nelson (1975). Early work showed that active PSI preparations free of Cyt *b*₆ and *f* can be obtained (Wessels, 1966, 1968; Boardman and Anderson, 1967; Nelson and Racker, 1972). Consequently, it was concluded that Cyt *b*₆ and *f* take no part in the light-induced elec-

iron transport from plastocyanin (PC) to NADP. It was shown that following digitonin treatment a PSI preparation that was depleted of the Cyt b_6-f complex was obtained (Nelson and Racker, 1972). It was used as a source for the preparation of PSI RC complexes free of Cyt using Triton X-100 and DEAE chromatography (Bengis and Nelson, 1975). This eliminated the Cyt b_6-f complex (Nelson and Neumann, 1972), with its five different polypeptides (9, 13, 17, 25, and 34 kD) (V. Goor and N. Nelson, unpublished results), from the PSI RC preparation. It is noteworthy that one can eliminate the digitonin treatment step in the PSI RC preparation from peas and go directly to the DEAE column, following solubilization of the chloroplasts in 4% Triton X-100 (N. Nelson, unpublished results). The purified PSI RC complexes (see Fig. 18 for absorption spectra) were active in NADP photoreduction when ascorbate served as an electron donor. Ferredoxin, ferredoxin-NADP reductase and PC were absolutely required for the reaction (Bengis and Nelson, 1975). Photosystem I RC complexes contain six polypeptides (see Fig. 19). Treatment of this preparation with SDS yielded a homogeneous preparation which was active in light-induced absorbance changes of P700. These preparations contain the RC of PSI and were termed P700-RCs by Bengis and Nelson. They contained one polypeptide hav-

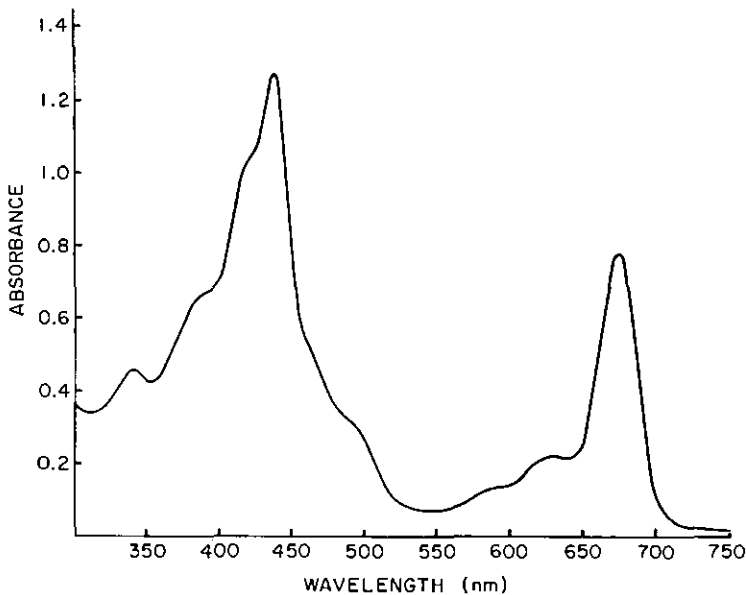

FIG. 18. Absorption spectrum of purified PSI RC preparations from swiss chard. (From Bengis and Nelson, 1975.)

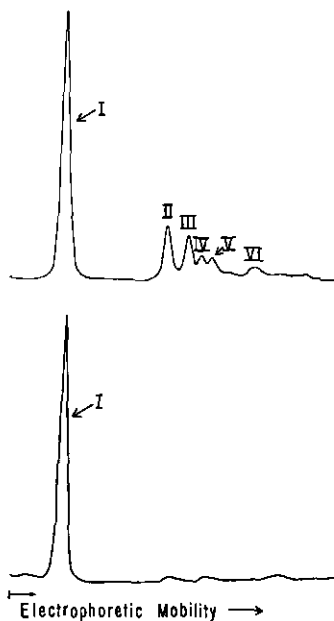

FIG. 19. SDS gel electrophoresis patterns of PSI RC preparation (top), and of P700 RC preparation (bottom) from Swiss chard. (From Bengis and Nelson, 1975.)

ing a MW of $\sim 70,000$ (see Fig. 19) (Bengis and Nelson, 1975). In addition they contained ~ 40 Chl *a* molecules, ~ 1 β -Car per P700 and no observable Chl *b*. Since these preparations still contain antennae Chl *a*, they cannot be considered analogous to the RC from bacteria.

2. PROTEIN STRUCTURE

a. Subunit Structure. Photosystem I RC complexes from Swiss chard contained six different polypeptides that were designated as subunits I, II, III, IV, V, and VI with apparent MW of 70,000, 25,000, 20,000, 18,000, 16,000, and 8,000 respectively (Bengis and Nelson, 1975, 1977; Nelson and Notsani, 1977) (see Fig. 19, top figure). The five low MW polypeptides have different relative mobilities in slab gels using Tris-glycine buffer (N. Nelson, unpublished results). The preceding MW values should, therefore, be considered only approximate. A subunit stoichiometry of 2 : 1 : 1 : 1 : 1 for subunits I, II, III, IV, and V, respectively, was proposed. The P700-RC is the 70 kD subunit I of PSI RC complex (see Fig. 19, bottom).

Several other studies support the conclusion that a 70kD polypeptide is functioning as the "P700-RC." Takamiya (1971) described purification procedures yielding Chl-protein complexes from several sources with

MWs of ~70,000. Machold (1975) showed that the Chl-protein complex I from tobacco that was discovered by Ogawa *et al.* (1966), and studied in detail by Thornber (1975), has a MW of 69,000. Chua and co-workers (Chua and Bennoun, 1975; Chua *et al.*, 1975) compared SDS gels of chloroplast membranes from *Chlamydomonas*, spinach, and Chinese cabbage and found that the Chl-protein complex I has a MW of 64–66,000. They also found that two mendelian mutants of *Chlamydomonas*, which were deficient in PSI activity, lacked the 66 kD polypeptide.

It was suggested that P700-RC preparations contain one P700 molecule per two polypeptides, each having a MW of 70,000 (Bengis and Nelson, 1975). To test this hypothesis, cross-linking experiments were performed with P700-RC preparations in solution. Treatment with two different concentrations of hexamethylenediisocyanate increased the MW of the preparation from 70,000 to ~140,000 with an overall yield of 95% (see Fig. 20). This experiment leaves little doubt that the P700-RC preparation is a dimer of two 70 kD polypeptides. The two 70 kD polypeptides in the dimer need not be identical. Indeed, one frequently observes a splitting of subunit I in SDS gels (Bar-Nun *et al.*, 1977; N. Nelson, unpublished results). In addition, Chua *et al.* (1975) showed that upon heating samples of *Chlamydomonas* membranes, before the application of SDS gels, only one of the two polypeptides in the position of 64 kD disappeared.

The role of subunits II–VI has been investigated by several workers. It has been suggested that subunit III mediates the reduction of P700⁺ by PC (Bengis and Nelson, 1977; Nelson and Notsani, 1977). This could come about either by providing the binding site for PC (Bengis and Nelson, 1977) or by serving as an electron carrier between PC and P700 (Bouges-Bouquet and Delosme, 1978). The former proposal was supported by the work of Haehnel *et al.* (1980), which showed that PSI RC preparations that were deficient in their ability to oxidize PC were also deficient in subunit III. In addition, these studies showed that the rate of reduction of P700⁺ by PC in RCs that contained subunit III was proportional to the PC concentration. This proves that subunit III does not contain an intermediate donor preceding P700. Mild treatment of PSI RC complexes with SDS led to parallel loss of its NADP photoreduction activity and its ESR signals from the iron-sulfur proteins. Concomitantly, subunits IV, V, and VI were released from the complex. It was suggested, therefore, that these subunits are the three iron-sulfur proteins of PSI (Bengis and Nelson, 1977; Nelson and Notsani, 1977). The P700-RC preparation was found to be depleted of all the iron-sulfur proteins (Nelson *et al.*, 1975), but was believed to contain the primary

*See Parson and Ke, Chapter 8, and Cramer and Crofts, Chapter 9, this volume.

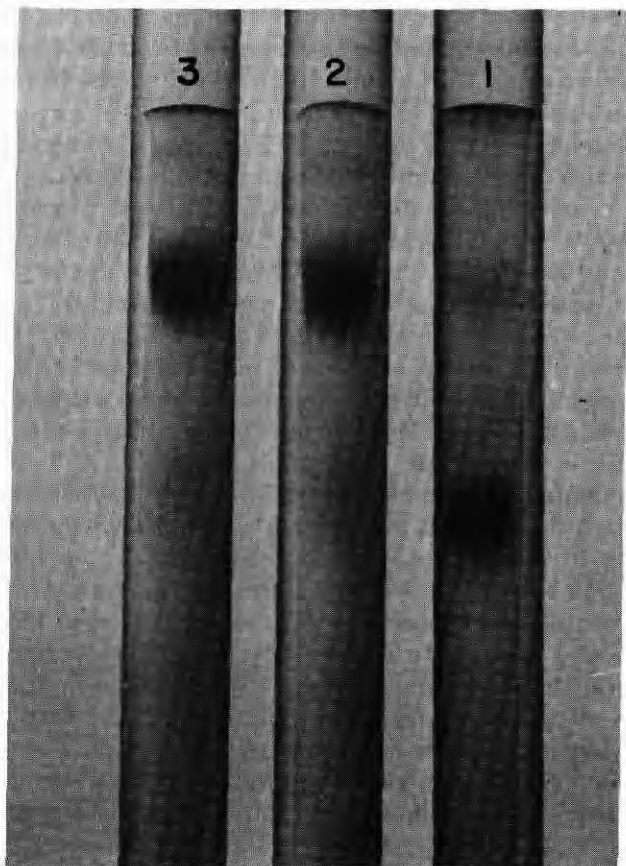

FIG. 20. Cross-linking of P700 RC from swiss chard with hexamethylenediisocyanate. P700-RC complexes containing ~ 0.1 mg Chl per ml were dialyzed against 200 ml of 50 mM sodium phosphate buffer (pH 8) at 4°C . Aliquots of 0.1 ml were incubated for 30 min at room temperature in the presence of the following concentration of the cross-linker: (1) control, (2) 0.01% hexamethylenediisocyanate, and (3) 0.05% hexamethylenediisocyanate. The cross-linker was added as a 0.5% solution in dimethylsulfoxide (freshly prepared). The reaction was quenched by addition of $20\ \mu\text{l}$ of 10% SDS and $2\ \mu\text{l}$ of β -mercaptoethanol. Solid sucrose was added to give a final concentration of about 10% w/v and $50\ \mu\text{l}$ samples were run on 5% polyacrylamide gels in the presence of SDS. (N. Nelson, unpublished results.)

electron acceptor ($A_{1,1}$)* (Nelson and Notsani, 1977). The presence of $A_{1,1}$ in SDS-treated chloroplast preparations that lost the secondary electron acceptors was further substantiated by the experiments of Mathis *et al.* (1977).

Subunit I of PSI RC complexes contains reactive groups that cause aggregation with itself and with neighboring subunits at elevated tem-

peratures (Nelson and Bengis, 1975; Nelson and Notsani, 1977). This phenomenon was used to deduce that subunits V and II are the nearest neighbors of subunit I (Nelson and Notsani, 1977). The heat treatment experiments also provided independent evidence that subunit I in PSI RC preparations, as well as in P700-RCs, appear in dimeric form.

The structure of the pigment molecules in the PSI RC complex and P700-RC complex was studied by biochemical and spectroscopic approaches. P700-RC complexes contain about 40 Chl *a* molecules per P700 pigment. Larger amounts, ~80 Chl *a* per P700 are associated with the PSI RC. However, the Chl *a* content can be reduced and ratios as low as 10 Chl per P700 are obtained (Bengis and Nelson, 1977). Nevertheless, it seems as if the 40 Chl *a* molecules, per P700, together with the two 70 kD polypeptides, serve as the primary antenna (Bengis and Nelson, 1977; Nelson and Notsani, 1977). Whether this primary antenna can be separated from P700 is not yet clear. Junge *et al.* (1977) studied the mutual orientation of pigments in PSI RC complexes by photoselection with polarized light. When the number of Chl per P700 was reduced from 100 to 40, the dichroic ratio increased from 1.2 to 1.33. Further depletion of Chls caused a decrease in the dichroic ratio (W. Junge and N. Nelson, unpublished observations). It seems, therefore, that about 40 Chl *a* molecules are specifically organized in PSI RC complex to give dichroic ratio characteristic of a circularly degenerate system. A very high degree of order between β -Car molecules and Chl *a* molecules that exhibit the largest red shift was also observed.

Studies with specific antibodies to subunit I showed that this subunit protrudes from the thylakoid membrane (Bengis and Nelson, 1975; Nelson and Bengis, 1975).

The overall subunit structure of PSI RC complex was recently confirmed, and the work extended to include their interaction with Chl-protein complexes (Mullet *et al.*, 1980). Photosystem I RC complexes have recently been reconstituted into phospholipid vesicles. In the presence of ascorbate and phenazine methosulfate, light-induced proton uptake producing a pH gradient of about three units was observed (Orlich and Hauska, 1980). Incorporation of a purified ATPase complex from chloroplasts brought about reconstitution of photophosphorylation (Nelson and Hauska, 1979; Hauska *et al.*, 1980). These experiments show that purified PSI RC complexes preserve all of the photobiochemical activities of PSI.

b. Amino Acid Composition. The amino acid composition of P700-RC particles from swiss chard (Nelson and Notsani, 1977) is shown in Table III. Similar amino acid compositions were obtained for the P700-Chl *a* complexes from *Phormidium luridum* and spinach beet

TABLE III
Amino Acid Composition of P700 RC Complex
from Swiss Chard^a

Amino acid	Mole %
Asp	7.65
Glu	7.73
Lys	2.13
His	3.42
Arg	3.63
Thr	5.83
Ser	7.02
Gly	10.12
Ala	9.83
Val	6.32
Ile	6.26
Leu	11.81
Pro	4.29
Met	1.35
½ Cys	2.46
Tyr	3.56
Phe	6.58
Polar ^b	37.4

From Nelson and Notsani (1977).

^bSum of (Asp + Asn), (Glu + Gln), Lys, His, Arg, Thr, Ser.

(Thorner *et al.*, 1977). One major difference, however, is that the P700-RC complex from swiss chard contains significantly more ½ cystines (i.e., 1 cysteine) than reported for the P700-Chl *a* preparations. Since several acceptor species are thought to be Fe-S proteins in which Fe is coordinated to cysteine, these measurements may be important in determining the location of the Fe-S center.

A feature of the amino acid composition is the low proportion of polar amino acid residues (37%) that is characteristic of intrinsic membrane proteins. The amino acid compositions of RCs from bacteria (LMH) and PSI are very similar (compare Tables II and III) as shown by their low compositional divergence (see Section V).

3. NATURE OF THE PRIMARY REACTANTS

The nature of the primary reactants in PSI has been clarified by spectroscopic and kinetic measurements (for earlier reviews, see Ke, 1978; Blankenship and Parson, 1979a; Hoff, 1979; Sauer, 1979). The data can be explained by a sequence of events with the participation of

TABLE IV
Some Properties of Donors and Acceptors in RCs from Bacteria and Green Plants^{a,b}

	Purple bacteria	PSI	PSII
Primary donor (D _I)	P870 (BChl) ₂	P700, D _I (Chl) ^c	P680, D _{II} (Chl) ^c
Name			
Chemical Identity			
Optical absorption (D _I)			
Characteristic λ_{\max} (nm)	870 ¹	700 ²	680 ³
ESR (D ⁺)			
<i>g</i> value	2.0026 ⁴	2.0025 ⁵	2.0026
ΔH (gauss)	9.5 ⁴	7.1 ⁵	6-8 ⁶
ΔH of model compound (Gs)	13.0 ⁴ (BChl ⁺)	9.3 ⁵ (Chl ⁺)	7-8-9.27 (Chl ⁺)
Midpoint potential (D ^{+/D})			> 0.81 ⁰ (est)
<i>E_m</i> (V)	0.44 ⁸	0.5 ⁹	
Intermediate acceptor (A _I)			
Name	I	I, A _{I,1}	I, W, A _{II,1}
Chemical identity	Bph	(Chl) _n , n=1 or 2	Ph
Optical absorption (A _I)			
Characteristic λ_{\max} (nm)	760 ¹¹	700 ¹²	685 ¹³
ESR (A _I ⁻)			
<i>g</i> value	2.0036 ¹⁴	2.0025 ¹⁵	2.0035 ¹⁶
ΔH (gauss)	12.9 ¹⁴	12-14 ¹⁵	12.5 ¹⁶
ΔH of model compound (Gs)	13.3 ¹⁴ (Bph ⁻)	12.1 ¹⁷ (Chl ⁻)	12.2 ¹⁷ (Ph ⁻)
Midpoint potential (A _I /A _I ⁻)			
<i>E_m</i> (V)	-0.6 ¹⁸	< -0.7 ¹⁰ (est)	- 0.61 ¹⁹

the following reactants. The primary donor species, P700, is a Chl species (see discussion below); it transfers its electron to an intermediate acceptor, $A_{1,1}$, a tetrapyrrole species probably Chl *a*. (See also discussions in Wraight, Chapter 2, Parson and Ke, Chapter 8, and Pearlstein, Chapter 7, this volume.) The reduced $A_{1,1}$ transfers its electron to $A_{1,2}$ (also called X), which has been postulated to be an Fe-S complex. $A_{1,2}$ subsequently reduces $A_{1,3}$ and $A_{1,4}$ two Fe-S centers that are also called P430A and B (see Fig. 17; Table IV).

a. Primary Donor—Chl *a*. Oxidation of the primary donor P700 can be achieved photochemically as first demonstrated by Kok (1956). The E_m for the oxidation of P700 was initially determined by Kok (1961) to be 0.43 V. Subsequent determinations yielded a range of values between +0.46 and +0.53 V (Rumberg, 1964; Yamamoto and Vernon, 1969; Knaff and Malkin, 1973; Ke *et al.*, 1975), although a lower value has been obtained by Evans *et al.* (1977). The major optical absorption changes due to the oxidation of the primary donor is the bleaching of two red bands: a major band at ~ 700 nm and a minor band at 685 nm (Ke, 1978; also see Witt, 1975) (Fig. 21). In addition, the Soret peak at 435 nm is also bleached. The exact absorption maxima vary slightly depending upon the preparation. Increases in absorbance due to the P700⁺ cation radical are observed in the near IR between 700 nm and 900 nm (see Parson and Ke, Chapter 8, this volume). The main features of these changes are similar to those observed upon oxidation of Chl *a*

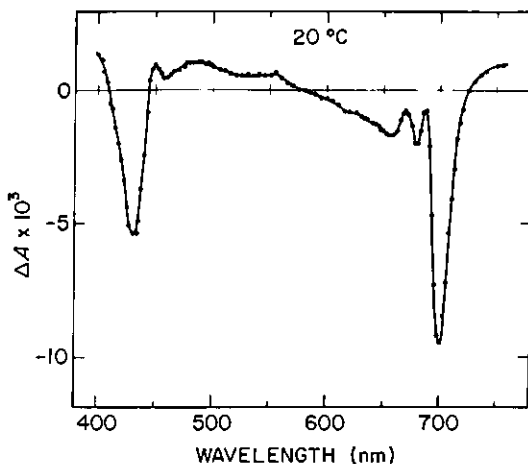

FIG. 21. Optical absorption changes (light-minus-dark) due to P700 photooxidation in a PSI RC preparation (TSFI) from spinach. The difference spectrum was measured by continuous illumination. (From Shuvalov *et al.*, 1979.)

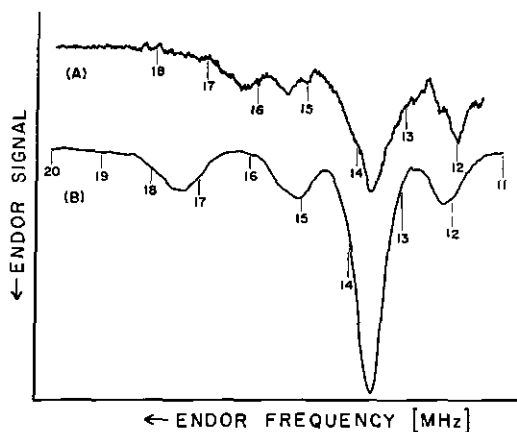

FIG. 22. ENDOR spectrum of (A) P700⁺ in *Synechococcus lividus* oxidized with K₃FeCN₆ compared with (B) oxidized Chl *a* (Chl *a*⁺) *in vitro*. The difference between these two spectra indicate that P700⁺ is not a Chl *a* monomer. (From Norris *et al.*, 1975. Reprinted with permission from the New York Academy of Sciences.)

(Fuhrhop and Mauzerall, 1969), except that in P700 there is a shift to longer wavelength and a splitting of the absorbance in the red (~685 nm and 700 nm). These changes may be due to an exciton interaction between chlorophyll molecules (Sauer, 1975), (see also Pearlstein, Chapter 7, this volume). [Changes in the CD spectra due to P700 oxidation were interpreted in terms of exciton interaction between at least two Chl *a* molecules (Phillipson *et al.*, 1972).]

The ESR signal of P700⁺ (Commoner *et al.*, 1956) is a single gaussian-shaped line at $g = 2.0025$ having a linewidth of 7.0 G. The linewidth of the monmeric Chl *a* cation radical *in vitro* is $\sim \sqrt{2}$ broader (9.3 G) than P700⁺ (Norris *et al.*, 1971; Katz *et al.*, 1978). The splittings of the ENDOR spectrum of P700⁺ differ significantly from that of Chl *a*⁺ (Fig. 22) and, in analogy with the bacterial donor, were rationalized in terms of a Chl *a* dimer (Norris *et al.*, 1974, 1975). However, a more detailed evaluation of the ESR and ENDOR data (Wasielewski *et al.*, 1981a,b) has cast doubt on this interpretation. The changes in ESR and ENDOR spectra were ascribed by Wasielewski *et al.* (1981a) to a modification of the chemical nature or environment of the Chl *a* molecule. These authors suggested that P700⁺ is a monomeric Chl *a* enol (a Chl *a* molecule enolized in ring V). Based on model studies, such a molecule would have an appropriate E_m , 0.5 V, significantly lower than that observed for Chl *a* itself. A new Chl species has been extracted from P700 enriched preparations (Dörnemann and Senger, 1981) and has been proposed to serve as the P700 chromophore. Thus the exact nature of P700 remains unresolved.

Photoinduced triplet ESR signals have been observed in PSI RC complexes in which the secondary acceptor, $A_{I,2}$ (X), was reduced (Frank *et al.*, 1979). These conditions were similar to those under which the triplet signals were observed in bacteria. However, the zero-field parameters D and E were the same as those observed for monomeric Chl a . If the triplet is localized on P700, this result can best be rationalized if P700 is a monomeric Chl species. It is not yet known whether the spectrum is consistent with the Chl a enol hypothesis. The spectrum could also be explained by a dimer model in which the Chl a magnetic axes are all parallel (Clarke *et al.*, 1977). Alternatively, the spin polarized triplet state may not be localized on P700 but on a nearby monomeric Chl a , perhaps, the acceptor, $A_{I,1}$.

b. Intermediate Acceptor—Chl a . The existence of an initial or intermediate electron acceptor analogous to that found in bacterial RCs was suggested by transient absorbance changes observed in PSI RC preparations in which the acceptors $A_{I,2}$, $A_{I,3}$, and $A_{I,4}$ (i.e., centers X, Fe-S-B and Fe-S-A) were reduced (Sauer *et al.*, 1978). Similar optical changes were later shown to occur in PSI RC complexes prepared with SDS (Mathis *et al.*, 1978). Also, similar SDS-treated preparations were found to lack functional Fe-S centers (i.e., X, Fe-S centers A and B) (Nelson *et al.*, 1975; Malkin *et al.*, 1976). These optical transients were also seen in RCs in which the Fe-S centers were destroyed by heat treatment (Baltimore and Malkin, 1980b). Additional evidence for an intermediate acceptor came from the observation of a spin-polarized ESR signal (Blankenship *et al.*, 1975). This signal was interpreted by Friesner *et al.* (1979) in terms of the existence of an intermediate acceptor that was predicted to have a narrow ESR signal.

The optical absorption spectrum of the reduced PSI intermediate acceptor was deduced from optical changes at low temperature (Shuvalov *et al.*, 1979) (see Fig. 23). The light-minus-dark spectrum showed negative peaks at 445 nm and 700 nm and positive bands at 480 nm and 672 nm. These changes are similar to the ones observed for the Chl a anion radical (Fujita *et al.*, 1978). Shuvalov *et al.* have proposed that these spectral changes indicate that the intermediate is a Chl a dimer. The lack of peaks in the difference (light-dark) spectrum near 500 nm and 550 nm (Shuvalov *et al.*, 1979; Baltimore and Malkin, 1980b) is consistent with the reported absence of Ph in PSI RC preparations (Thorner *et al.*, 1977). The redox potential of I has not been measured. It must, however, be lower than -0.73 V, the value assigned to the subsequent acceptor $A_{I,2}$ (X) (Ke, 1978). The redox potential for Ph *in vitro* (-0.64 V) appears to be too high, whereas that of Chl a (-0.88 V) is sufficiently low (Fujita *et al.*, 1978) to account for its role as $A_{I,1}$. The assignment of the

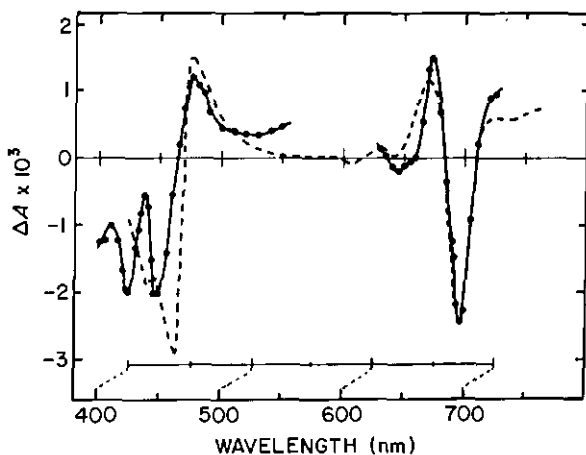

FIG. 23. Optical absorption changes (solid line) due to the photo-reduction of the intermediate acceptor, A_{I-1} , in a PSI RC preparation (TSFI) from spinach. The spectrum was obtained by subtracting the changes due to D_{I-1}^+ from the flash-induced spectrum due to the formation of $D_{I-1}^+A_{I-1}^-$. The optical changes due to Chl a reduction are shown for comparison (dashed line). The wavelength scale for Chl has been shifted (upper scale). (From Shuvalov *et al.*, 1979.)

first acceptor to a Chl-type species is also suggested by picosecond measurements on P700-enriched particles (Fenton *et al.*, 1979). (For further discussion, see Parson and Ke, Chapter 8, this volume.)

Shuvalov *et al.* (1979) reported the observation of a narrow asymmetric ESR signal ($g = 2.004$, $\Delta H = 10$ G), which decayed with the same characteristic time (1 msec at 5°C) as the optical transients due to D^+I^- . However, because of spin polarization and interactions with $P700^+$, the ESR signal of I^- was not reliably characterized by the pulse method. ESR spectra of I^- have been better characterized in various PSI preparations, obtained with either Triton (Heathcote *et al.*, 1979) (Fig. 24), digitonin (Heathcote and Evans, 1980), or SDS (Baltimore and Malkin, 1980a). The I^- radical was trapped by illuminating the RCs during freezing at low redox potential. Differences in the ESR spectra were found between various preparations. These variations could be either ascribed to changes in the environment of A_{I-1}^- or to electron transfer to another acceptor species. The smallest of these particles (P700-RC) prepared in SDS had the other acceptors removed. They had an ESR spectrum with a $g = 2.0025$ and $\Delta H = 12$ G (Baltimore and Malkin, 1980a). These values are close to those observed from the monomeric Chl (or Ph) anion radical ($g = 2.0030$, $\Delta H = 12.1$ G) (Fujita *et al.*, 1978).

No resolved splitting of the I^- radical signals due to magnetic interaction with the next acceptor species, X^- (X_2^-) (a paramagnetic species

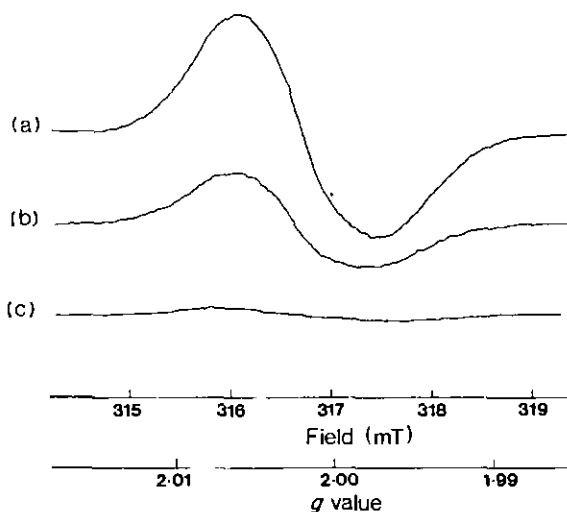

FIG. 24. ESR spectra (first derivative) of I^- in PSI particles from spinach. Samples were illuminated at room temperature in the presence of sodium dithionite and (a) frozen while illuminated. Samples for spectra (b-c) were frozen at 0 and 30 sec after illumination. T , 77 K; ν , 8.898 GHz. (From Heathcote *et al.*, 1979.)

with g values of 2.09, 1.90, and 1.78) has been observed. However, a loss of amplitude of the X^- ESR signal has been reported (Heathcote and Evans, 1980) and interpreted as an indication of a magnetic interaction between $A_{I,1}^-$ and $A_{I,2}^-$.

c. Electron Acceptor X. When PSI particles were illuminated at sufficiently low potentials (-0.6 V) to reduce subsequent acceptors, a reversible light-induced oxidation of P700 was observed (Sauer *et al.*, 1978). Redox titration of this photochemical activity showed it to be associated with an acceptor species with E_m (pH 10) ≈ -0.73 V (Ke *et al.*, 1977).

The optical changes associated with the reduction of this acceptor species, called X or $A_{I,2}$ exhibit a broad featureless bleaching of a band from 400 to 550 nm and sharp peaks due to band shifts near 450, 670, and 680 nm (Shuvalov *et al.*, 1979) (Fig. 25). The broad band in the 400–550 nm region was attributed to Fe–S absorption, whereas the remaining sharp features were attributed to electric field shifts in adjacent Chl molecules.

The ESR signal associated with X^- ($A_{I,2}^-$) was first observed at cryogenic temperatures by McIntosh *et al.* (1975) and extensively characterized by Evans and co-workers (M. C. W. Evans *et al.*, 1975, 1976,

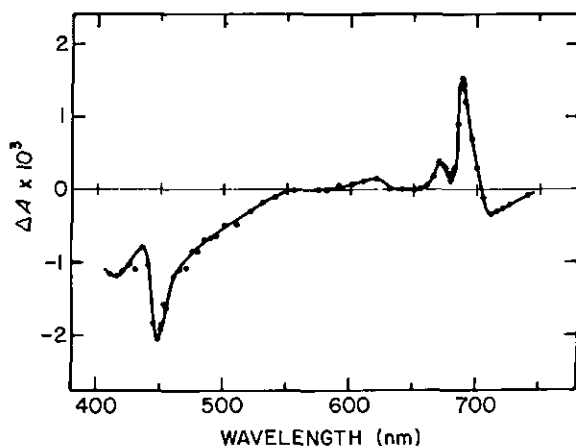

FIG. 25. Optical changes (light-minus-dark) due to photoreduction of $A_{1,2}$ in a PSI RC preparation (TSFI) from spinach. The sample was illuminated at 4°C and was at a low redox potential (-0.625 V). The absorbance change consists of the bleaching of a broad band from 400–550 nm and sharp bands due to electrochromic shifts in adjacent Chl molecules. (From Shuvalov *et al.*, 1979.)

1977; Heathcote *et al.*, 1978) (Fig. 26). The ESR signal has g values of 2.08, 1.90, and 1.78 and exhibits non-Curie law behavior decreasing sharply at temperatures below 10°K (M. C. W. Evans *et al.*, 1976). Attempts to measure line broadening in isotopically enriched ^{57}Fe samples failed (E. H. Evans *et al.*, 1976). This may have been due to the broad linewidth of the X^{-} signal.

Shuvalov *et al.* (1979) showed that the ESR signal at $g = 1.78$ decays with the same kinetics (130 msec at 5°K) as the optical absorbance changes of $A_{1,2}$. This shows that the same acceptor species gives rise to both effects. The chemical nature of $A_{1,2}$ remains undetermined. The g values of the ESR spectrum lie outside the usual range found for Fe–S centers (Sands and Dunham, 1975). It is, therefore, either a modified Fe–S center or as Bolton (1977) has suggested, an organic free radical– Fe^{2+} complex in analogy with the quinone– Fe^{2+} complex found in bacterial RCs. It will be instructive to see if the experimental approaches used in elucidating the structure of the Q–Fe complex in bacterial RCs, such as removal of Fe, and quinone (or cofactor) extraction could be used to elucidate the nature of $A_{1,2}$.

d. Secondary Electron Acceptors—Bound Iron–Sulfur Centers A and B. The participation of bound Fe–S proteins as acceptor species in PSI was first suggested by Malkin and Bearden (1971) who observed an

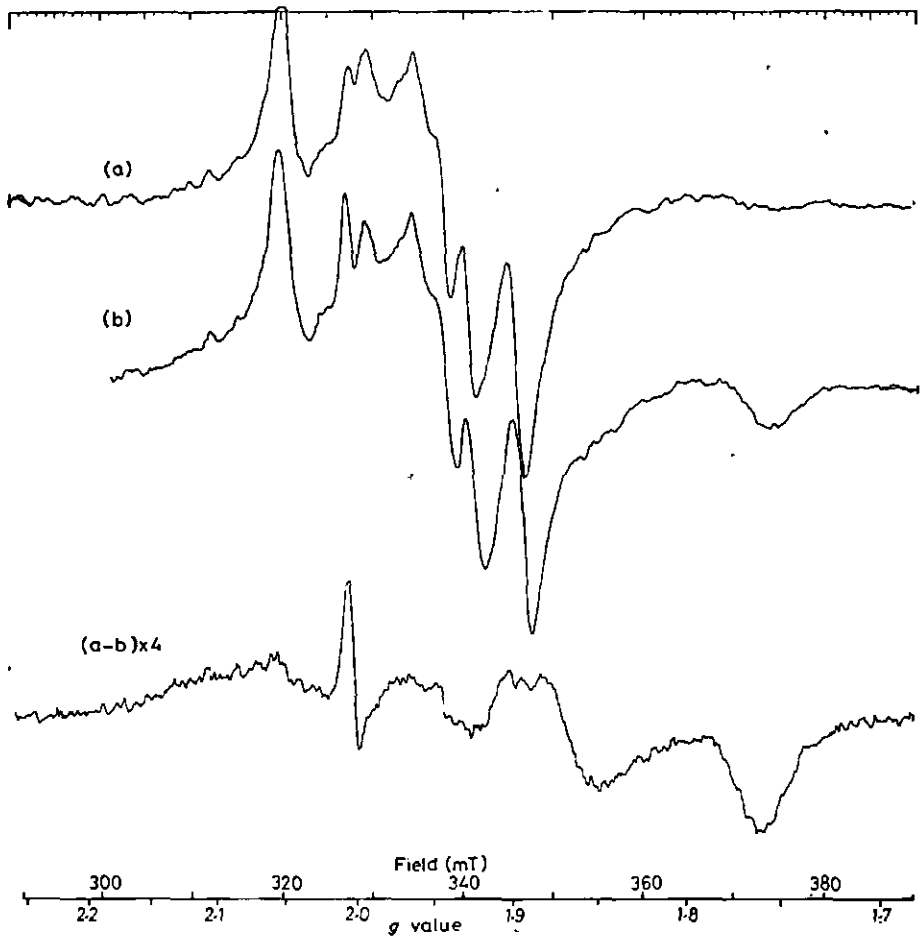

FIG. 26. The light induced ESR spectrum (first derivative) of $X^- (A_{1,2})$ in a PSI RC preparation made with Triton X-100 (bottom). The dark adapted sample (top) was illuminated in the ESR spectrometer (middle). T , 10 K, ν , 9.25 GHz. (From M. C. W. Evans *et al.*, 1976b.)

ESR signal (center A) (g values 2.05, 1.94, and 1.86) that was irreversibly formed by illuminating chloroplasts at cryogenic temperature (Fig. 27) (see Ke, 1978; Malkin and Bearden, 1978, for reviews). An additional ESR signal assigned to bound Fe-S center having g values of 2.05, 1.92, and 1.89 was observed by Evans *et al.* (1974). This signal could not be obtained by photoreduction at low temperature but was produced by illumination at room temperature in the presence of suitable reductants (Malkin and Bearden, 1978). It is not clear at present whether centers A

and B accept electrons from X ($A_{1,2}$) in parallel or in series (B reduced before A) (Malkin and Bearden, 1978). The redox potentials of centers A and B were determined to be -0.53 V and -0.58 V, respectively (Ke *et al.*, 1973a; Evans *et al.*, 1974). At about the same time that the ESR spectra were investigated, the optical absorption of an acceptor species, P430, was characterized by Hiyama and Ke (1971) (Fig. 28). The difference spectrum (reduced minus oxidized) of this species shows a loss of a broad band with a peak at about 430 nm. Extensive studies have correlated these changes with the reduction of the Fe-S centers A and B. However, definitive proof is lacking (see Ke, 1978; also Parson and Ke, Chapter 8, this volume).

Evidence that centers A and B are bound Fe-S proteins comes from the similarity between their ESR signals and those of known Fe-S proteins. For example, soluble spinach ferredoxin has g values of 2.05, 1.96, and 1.89 (Sands and Dunham, 1975). Chemical evidence indicates the presence of 10–12 acid labile sulfides and 10–12 non-heme Fe per P700 in PSI RC particles (Golbeck *et al.*, 1977), although a lower Fe content [4.6 Fe per P700] has been reported by Bengis and Nelson (1975). Cammack and Evans (1975) have done iron extraction experiments

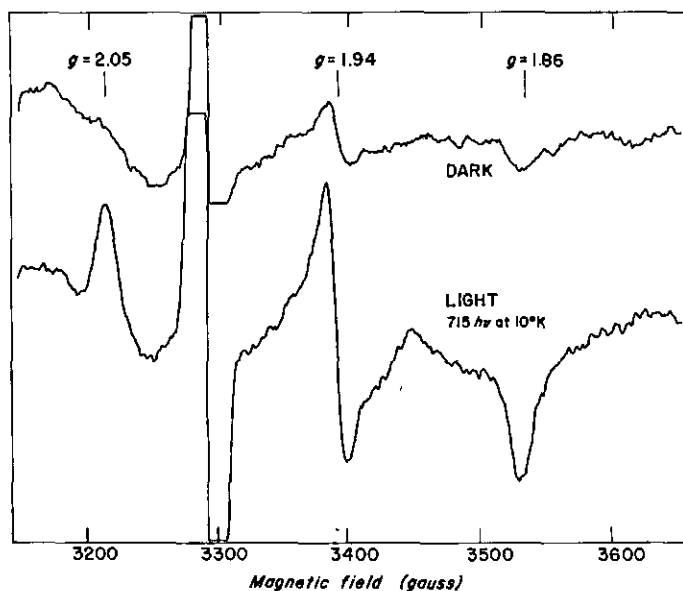

FIG. 27. ESR spectra (first derivative) of spinach chloroplasts before and after illumination at 10°K ($\lambda = 715$ nm). The light induced ESR signal is due to the Fe-S center A, which serves as an acceptor in PSI. (From Malkin and Bearden, 1978.)

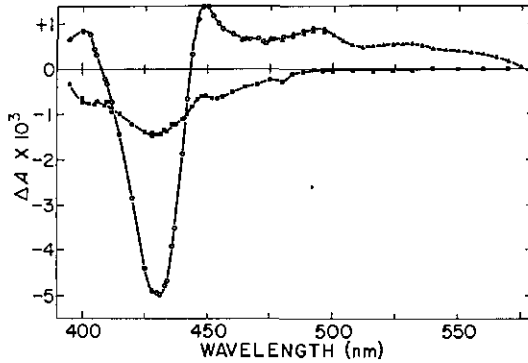

FIG. 28. Optical absorption changes (reduced-minus-oxidized) due to acceptor species P430 (■) in a PSI RC preparation from spinach. Changes due to P700 oxidation (○) are also shown. (From Hiyama and Ke, 1971.)

using DMSO and concluded that there are two 4-Fe-sulfur centers and no 2-Fe-sulfur centers in PSI. However, the interpretation has been questioned by Malkin and Bearden (1978). Golbeck *et al.* (1977) and Golbeck and Kok (1978) studied the effects of denaturing conditions on Fe-S centers and photochemical activity (Golbeck *et al.*, 1977; Golbeck and Kok, 1978). By using urea and ferricyanide, which oxidize labile sulfide, they showed a linear relation between the loss of P700 photooxidation and the loss of labile sulfide (up to 12 sulfur/P700). They

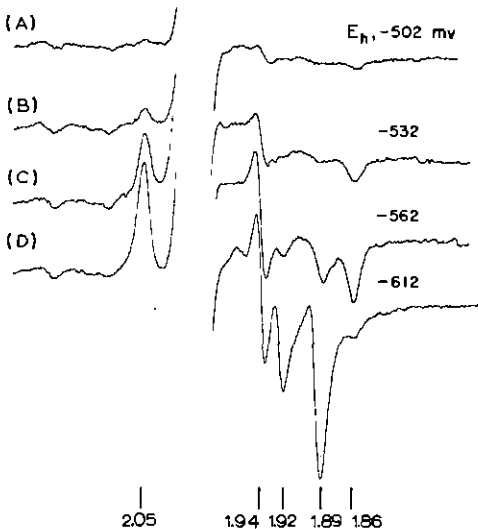

FIG. 29. ESR spectra (first derivative) of Triton PSI subchloroplast fragments at different stages of reductive titration at pH 10 showing the presence of Fe-S centers. The ESR signal at $g = 1.86$ diminishes at lower potentials. (From Ke *et al.*, 1973a.)

suggest that this linearity implies a cooperative destruction of the Fe-S center, i.e., that all of the Fe-S centers are intimately bound, perhaps in the same protein (Golbeck and Kok, 1978).

An interesting feature of the ESR spectrum of the Fe-S centers is the observed loss of the peak at $g = 1.86$ assigned to center A at lower potentials. This loss occurred concomitantly with the reduction of center B (Ke *et al.*, 1973a; Evans *et al.*, 1974) (Fig. 29). Evans *et al.* (1974) attribute this loss to a spin-spin interaction between centers A and B. This interpretation would require a close proximity (5–10 Å) between the two centers. Alternatively, the loss of this signal could be due to the further reduction of the species giving rise to the signal (Ke *et al.*, 1973a).

B. Photosystem II

1. REACTION CENTER COMPLEX PREPARATIONS

Several RC preparations of varying degrees of purity have been reported (see Table 1). Vernon and co-workers (1966, 1971); Vernon and Shaw (1971); Vernon and Klein (1975), and Ke *et al.* (1975) have developed a sucrose gradient fractionation procedure using Triton X-100. Wessels *et al.* (1973) utilized digitonin to obtain a similar preparation (also see Wessels, 1966; Wessels and Borchert, 1978). Both of these preparations contain multiple polypeptide components and lack PSI activity. Satoh has extended Wessels fractionation procedure using DEAE chromatography and isoelectric focusing to obtain what is believed to be a pure PSII RC preparation (Satoh and Butler, 1978; Satoh, 1979) (Fig. 30). These RC preparations possess the capacity to photo-oxidize 1,5-

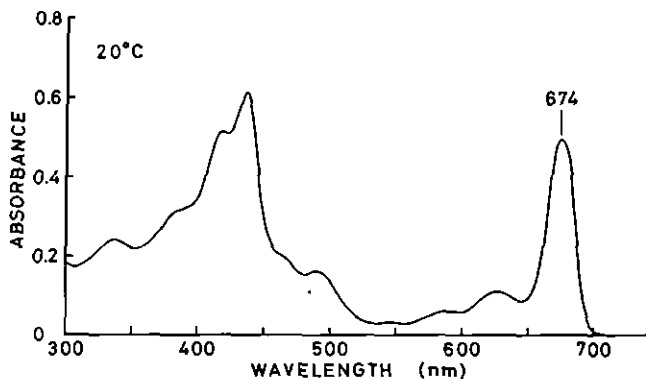

FIG. 30. Optical absorption spectrum of PSII RC complexes from spinach prepared by using digitonin. (Courtesy of K. Satoh.)

diphenyl carbazide using various acceptors, e.g., dichlorophenol–indophenol, a reaction specific for PSII RCs (Vernon and Shaw, 1969). However, they lack the capacity to oxidize H_2O to O_2 . Two photochemically inactive preparations were obtained from *Chlamydomonas* using lithium dodecyl sulfate (LDS) and electrophoresis at 4°C (Delepelaire and Chua, 1979). The two Chl–protein complexes obtained by this procedure were called CP III and CP IV; they had apparent MWs near 50,000 and 47,000, respectively. Satoh (1981) electrophoresed his digitonin PSII RC preparation in LDS and found a Chl–protein complex identical to CP III. Thus, CP III may contain part of the RC of PSII, although no photochemical activity has yet been demonstrated.

The PSII RC complexes have low PSI activity. They contain a Cyt b_{559} and plastoquinone (Vernon and Shaw, 1971). They have a large ratio of Chl a to Chl b , which indicates a lack of antennae protein. The ratio of Chl a to cyt b_{559} is ~20–50 (see Table I).

2. PROTEIN COMPOSITION

The subunit composition of different PSII RC complexes varies. A highly purified RC preparation contains three polypeptides that migrate in SDS with apparent MWs of 6, 500, 27,000, and 43,000 (Satoh, 1979, 1981) (Fig. 31). Other preparations appear to contain these subunits as well as others (Vernon and Klein, 1975; Wessels and Borchert, 1978; Satoh, 1981). The larger of the three peptides (43 kD) is thought to contain the Chl a associated with the PSII RC (Delepelaire and Chua, 1979; Satoh, 1981). The low MW polypeptide (~6.5 kD) is believed to be associated with Cyt b_{559} (Satoh, 1981). Heat treatment of the PSII RC complex in SDS and mercaptoethanol causes aggregation (Satoh, 1979). Similar observations have been made with RCs from bacteria and PSI. An additional protein (~32 kD) has been associated with the secondary PQ(B) binding site in PSII. This conclusion was based on proteolysis studies (Croze *et al.*, 1979; Renger *et al.*, 1981) and photoaffinity labeling (Pfister *et al.*, 1981; see Kaplan and Arntzen, Chapter 3, this volume).

3. NATURE OF THE PRIMARY REACTANTS

The primary reactants in PSII RCs are the primary donor P680, a Chl a species, the intermediate acceptor, a Ph- a , and two plastoquinones (usually labeled Q and B), which are probably close to a Fe^{2+} (see Fig. 17 and Table IV). The PSII photochemistry has been reviewed by Ames and Duysens (1977).

a. Primary Donor. Optical absorption transients from PSII were first reported by Döring *et al.* (1969). A major absorption at 680 nm was

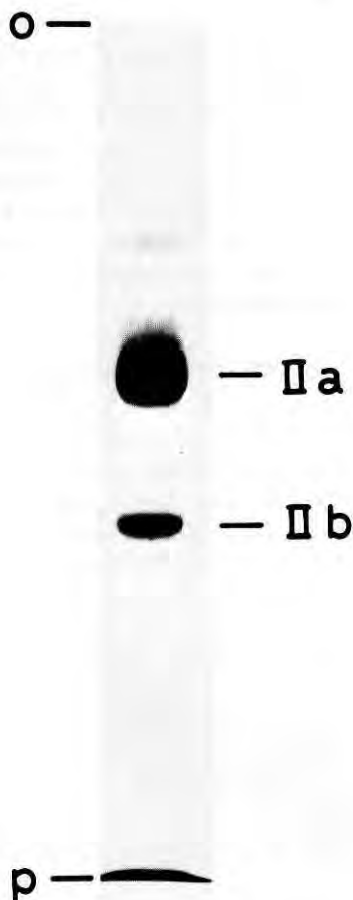

FIG. 31. SDS polyacrylamide gels of the PSII RC complexes from spinach (o, origin; p, pigment front). The estimated MW are IIa, 43 kD; IIb, 27 kD. The 6.5 kD component migrates at the pigment front. (From Satoh, 1979.)

observed and has been assigned to the primary donor of PSII, called P680 (see Fig. 17 in Parson and Ke, Chapter 8, this volume). The decay kinetics of P680 at room temperature are complex (Mathis *et al.*, 1977), probably reflecting reactions with several donors as well as back reactions with reduced acceptors. The low-temperature kinetics of P680 in a PSII preparation are reversible with a temperature independent half-time of 1–5 msec (Ke and Dolan, 1980; Mathis and Vermeglio, 1975). Although the redox potential for oxidation of P680 has not been reported, it has been estimated to be $\sim +1.1$ V (Jursinic and Govindjee, 1977).

The ESR spectrum of $P680^+$ was investigated using flash illumination at cryogenic temperature. It shows a reversible signal, which decays in a

few milliseconds (Malkin and Bearden, 1975; Visser *et al.*, 1977). The observed ESR signal was similar to that of $P700^+$, $g = 2.002$ with reported linewidths of 8 G (Malkin and Bearden, 1975) and 6–7 G (Visser *et al.*, 1977). Davis *et al.* (1979b) have shown that Chl *a* in nonpolar solvents forms a ligated complex that can have high redox potentials ($E_m = +0.9$ V in tetrahydrofuran). The linewidths of the ESR signals of these monomeric radicals were 7.8–9.2 G depending on solvent and counterion. If P680 is a ligated Chl *a*, then it could be either a monomer or a dimer. ENDOR data would be valuable in deciding between these two alternatives.

b. The Intermediate Acceptor—Pheophytin. Evidence for the presence of an intermediate acceptor ($A_{II,1}$) in PSII came from the observation of reversible photoinduced absorbance changes in PSII enriched particles upon illumination at low redox potentials (Klimov *et al.*, 1977a). The absorbance changes were correlated with a concomitant decrease in Chl *a* fluorescence from the PSII particle and are thought to be due to the photoreduction of an intermediate acceptor species. The absorbance changes (light-minus-dark) show a decrease at 680, 545, 518, 422, and 408 nm, and an increase at 448 and 605 nm (Fig. 32). The absorption changes near 550, 500, and 650 nm are characteristic of the formation of the Ph anion radical (Fujita *et al.*, 1978). The redox potential of the reduced acceptor was determined to be -0.61 V (Klimov *et al.*, 1979).

An ESR signal was observed upon illumination of a PSII preparation

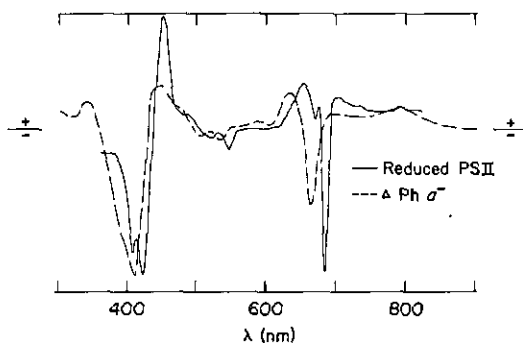

FIG. 32. Optical absorption changes due to photoreduction of the intermediate acceptor, ($A_{II,1} - A_{II,1}$), in a PSII RC preparation from spinach (solid line) (from Klimov *et al.*, 1977a) and absorption changes due to reduction of pheophytin ($Ph^{-} - a - Ph - a$) (dashed line). The loss of absorption peaks near 500 nm and 550 nm are characteristic of Ph *a*. (Reprinted with permission from Fujita, I., Davis, M. S., and Faher, J. (1978). *J. Am. Chem. Soc.* 100, 6280–6282. Copyright 1978 American Chemical Society.)

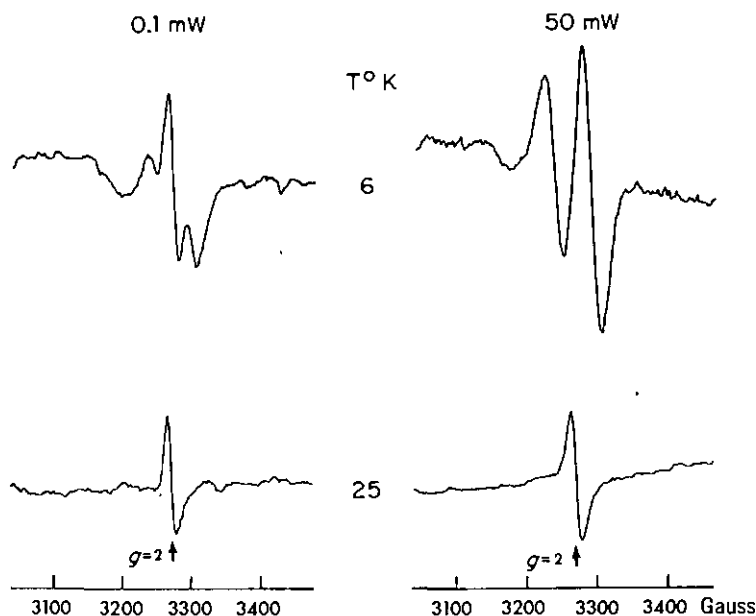

FIG. 33. ESR spectra (first derivative) due to photoreduction of I ($A_{11,1}$) in a PSII RC preparation (TSFIIa) from spinach. Samples were illuminated for 90 sec at 220°K ($E = -0.450$ V) then quickly cooled to 77°K. Spectra were taken at temperatures and microwave powers indicated. The doublet signal observed at high power and low temperature is indicative of a magnetic interaction. Similar signals have been observed in bacteria (see Fig. 13). (From Klimov *et al.*, 1980b.)

at low redox potential at room temperature. It has a g value of 2.0035 and $\Delta H = 12.5$ G (Klimov *et al.*, 1980a). These values are similar to those obtained for the monomeric Chl anion radical *in vitro* (Fujita *et al.*, 1978). When PSII RC particles were illuminated at 200°K, the ESR spectrum exhibited an asymmetric split signal with a splitting of 52–55 G. This signal saturated at a higher microwave power than the singlet signal (Klimov *et al.*, 1980b) (Fig. 33). The split signal is very similar to the ESR spectrum of I^- observed in bacterial RCs (see Fig. 13), where it is thought to be due to an exchange interaction between Bph^- and Q^-Fe^{2+} . An additional intermediate before pH has recently been suggested (see Chapter 2, this volume).

c. The Primary Acceptor—Plastoquinone. The reduction of the primary acceptor, $A_{11,2}$, in PSII was associated with the increase in PSII fluorescence (Duyens and Sweers, 1963) leading to its designation Q (“quencher”). The light-induced absorbance change due to the reduc-

Pheo/

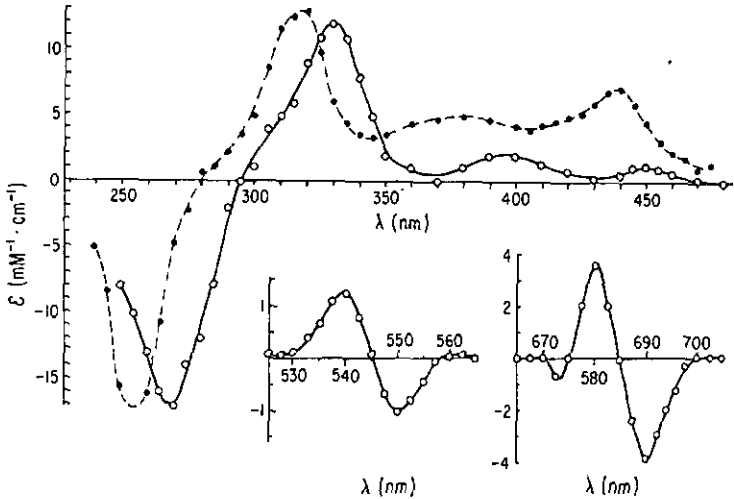

FIG. 34. Light-induced absorbance changes due to photoreduction of Q ($A_{II,2}$) in a PSII RC preparation from spinach (solid line). The dashed line is the optical change due to reduction of plastoquinone to plastosemiquinone *in vitro*. (In addition to optical changes characteristic of PQ reduction, band shifts centered around 545 nm and 685 nm are observed; these indicate the presence of a nearby Ph a molecule.) (From van Gorkom, 1974.)

tion of the PSII acceptor, characterized by an increase in absorbance at 320 nm, was first observed by Stiehl and Witt (1969) and assigned to PQ reduction. Van Gorkom (1974) obtained the complete spectrum of $A_{II,2}$ in PSII particles from which secondary acceptors were removed (Fig. 34). It resembled the changes due to the formation of semiquinone anion $Q^{\cdot -}$ (Bensasson and Land, 1973). In addition to absorbance changes attributed to PQ, shifts in bands centered around 545 nm and 685 nm were observed. These are probably due to changes in the Ph ($A_{II,1}$)* absorption spectrum arising from the reduction of the nearby quinone. The redox potential of Q as determined by the effect of photoreduction of Q on Chl a fluorescence from PSII gives two values, -0.045 V and -0.245 V (Cramer and Butler, 1969; Horton and Croze, 1979). For a detailed discussion on the heterogeneity in Q , see a review by Vermaas and Govindjee (1981).

The ESR signal of reduced Q has recently been observed in PSII particles from *Chlamydomonas reinhardtii* (Nugent *et al.*, 1981). The signal is broad with a peak near $g = 1.84$ similar to that seen in bacterial RCs.

*If it turns out that there is an intermediate prior to Ph in PSII (see Wraight, Chapter 2, this volume), the numbering system used in this book will have to be modified again.

This suggests that Q is also a quinone-Fe complex. Significant amounts of Fe have been found in PSII RC preparations (Knaff *et al.*, 1977; Klimov *et al.*, 1980c). Another close similarity between the primary acceptors of PSII and bacterial RCs is that the electron transport from both is inhibited by *o*-phenanthroline (Izawa, 1977). Although the effect of *o*-phenanthroline has been attributed to chelation of Fe, experiments by Oettmeier and Grewe (1974) with nonchelating analogs shed doubt on this interpretation (see also Section II,A,3,e).

Chemical evidence for the participation of PQ as an acceptor in PSII comes from studies of extraction of PSII RC preparations with organic solvents (0.2% methanol in hexane) (Knaff *et al.*, 1977). The P680 in the extracted particles could not be oxidized at cryogenic temperatures. Reconstitution with PQ restored the ability to oxidize P680. Importantly, the kinetics of the back reaction (between P680⁺ and Q⁻) was the same in the nonextracted and reconstituted preparations.

Klimov *et al.* (1980c) examined the split ESR signal believed to be due to interaction between Q⁻(A_{II,2}⁻) and Ph⁻(A_{II,1}⁻). Extraction with hexane containing a small amount of methanol eliminated the doublet splitting; reconstitution with PQ restored it. Treatment with LiClO₄ and *o*-phenanthroline removed Fe and also eliminated the I⁻ doublet. Addition of Fe²⁺ partially restored it. A new light-induced ESR signal ($g = 2.0044$, $\delta H \sim 8$ G) was observed after Fe removal, analogous to that observed in bacteria after similar treatment (Loach and Hall, 1972). The similarity between these results and those obtained with bacterial RCs (see Section II,A,3,c) indicates that the PSII acceptor is a complex of PQ with Fe.

d. The Secondary Acceptor—Plastoquinone. The mechanism of charge accumulation on the acceptor side of PSII was investigated using a series of single turnover flashes. Bouges-Bouquet (1973) found that the electrons available to PSI from PSII showed damped oscillations with a periodicity of two with peaks on even flashes. Independently, Velthuys and Amesz (1974), measuring diuron-induced Chl *a* fluorescence changes, also observed binary oscillations (with peaks on odd flashes). These results were interpreted in terms of another electron acceptor, A_{II,3} (called B or R), which functions in series with A_{II,2}(Q). Pulles *et al.* (1976) measured absorption changes at 320 nm and found oscillatory behavior with maximal change at odd flashes. The spectrum of these changes shows a peak at about 320 nm. This was taken as evidence that this acceptor species is also a PQ. Similar oscillatory behavior was observed later in bacterial RCs where the secondary acceptor is believed to be UQ (Vermeglio, 1977; Wraight, 1977) (see Section II,A,3,d).

IV. Concluding Remarks

It is becoming increasingly clear, as more information becomes available, that RCs from bacteria and green plants show striking similarities. This is not too surprising since it would be unusual if nature were to reinvent this complex unit to function in different organisms. Instead, it is likely that RCs from bacteria and green plants are closely related through evolution. A possible scenario of this evolutionary process is discussed at the end of this section. We shall start by delineating the similarities and differences of the photosynthetic systems.

The protein components of the RCs from purple bacteria, PSI and PSII, show some intriguing similarities. Although the subunit compositions of these three types of RCs are different (see Table I), there is an interesting numerical relationship between them. The bacterial RC contains three subunits (L, M., and H) with MW, as estimated by SDS - PAGE, of 21,000, 24,000, and 28,000. The smallest two subunits (21 and 24 kD) form an active dimer that contains the primary reactants. The RC complex of PSII contains a subunit of 43 kD, close to the size of the active unit in bacteria, and a 27 kD subunit, which may be analogous to the H subunit in bacteria. Although the RC complex of PSI consists of only one-size polypeptides, its MW of 70,000 is close to the sum of the MW of the subunits in bacteria and also of those in PSII. The amino acid composition of the bacterial RC and PSI RC complexes show a close similarity (see Tables II and III and Section V). Data from PSII are not yet available. Further studies, particularly of the amino acid sequences, will be very useful in future comparisons.

One apparent difference between the RC preparations from bacteria and those from PSI and PSII is the presence of ~ 30 Chl *a* antenna molecules in the latter two. If these Chl molecules are an integral part of the isolated RC complex, they may be associated with proteins. This may explain the apparently larger size of the RC complex in PSI (150–300 kD) compared to that in bacteria (90 kD). It may be possible, in the future, to separate the antenna complex from the RC, as has been done in bacteria. On the other hand, nature may have evolved a larger complex for green plants.

The primary reactants in the various RCs also show strong similarities, particularly between the donors in bacteria and PSI and the acceptors in bacteria and PSII. Table IV shows a summary of the properties of the donors and acceptors. All three RCs use tetrapyrrole molecules to perform the initial charge separation, i.e., as primary donor, D_1 , and in the intermediate acceptor, A_1 species. In photosynthetic bacteria, the donor species, D_1 , is a dimer of BChl *a*. In PSI, the donor, P700, was believed to be a Chl *a* dimer; however, more recent results suggest a

monomeric species, possibly a modified Chl derivative. The primary donor of PSII is a Chl species; a ligated Chl *a* has been suggested. The intermediate acceptor species, A_1 , are believed to be monomeric BChl, Bph, Ph, or Chl. However, the electron may not be completely localized on one of these molecules. Indeed, we may need to describe the electronic states of tetrapyrroles in the primary RC in terms of a coupled array with wave functions partially delocalized over several molecules (see Pearlstein, Chapter 7, this volume). The special properties of tetrapyrrole molecules which make them particularly suited for use as the primary reactants have been discussed by several authors (Sauer, 1975; Katz *et al.*, 1978; Mauzerall, 1978). These include: (1) a high absorption cross section for efficient excitation; (2) slow rates of radiationless decay; and (3) appropriate charge transfer states (e.g., D_1^+ , A_1^-) with proper oxidation reduction potentials to match the photon energy. The special properties of dimeric Chl or BChl (as compared to their monomeric counterpart) that may favor its use as the primary donor species include (1) the shift to longer wavelength (i.e., lower energies) leading, perhaps, to more efficient trapping of the excitation; (2) increased ease of oxidation; and (3) utilization of intermolecular motion to facilitate electron transfer (Warshel, 1980).

The structures of the primary and secondary acceptors, A_2 and A_3 , are more diverse. In bacteria and PSII, there appear to be two bound quinone molecules that serve as primary and secondary acceptors. The quinones are close (i.e., magnetically coupled) to a metal ion, Fe^{2+} . The role of the Fe^{2+} is still uncertain. It apparently is not, by itself, an electron transfer component. However, it is likely to be of importance to have survived the process of evolution from bacteria to green plants. In PSI, the primary acceptor, X, may be either an iron-sulfur center or an organic molecule associated with a metal ion. Further studies are needed to determine its identity. The secondary acceptors in PSI are membrane bound Fe-S centers.

Although many electron transfer components have already been delineated, it is possible that further, earlier steps will be discovered. For instance, in bacterial RCs the function of two BChl and one Bph molecules has not been determined. These may participate in the primary photochemistry at times shorter than our current instrumental limits ($\sim 10^{-12}$ sec). There are problems in detecting these early intermediates due to the high peak powers involved (see Parson and Ke, Chapter 8, this volume).

Although much progress has been made in the identification of the primary reactants in RCs, many problems remain to be solved before a clear picture of the RC emerges. Little is known about the structural organization of the reactants in the proteins. Although spectroscopic

studies have been used to determine the *orientation* of the reactants in the RC (see Breton and Vermeglio, Chapter 4, this volume; and Fig. 18 in that chapter), less is known about the *distances* between reactants. Several promising approaches have been used to estimate distances between reactants involving optical (Shuvalov and Asadov, 1979), ESR (Tiede *et al.*, 1978; Bowman *et al.*, 1979; Gast and Hoff, 1979; Okamura *et al.*, 1979a), and kinetic (Hopfield, 1979) measurements. These approaches are based on measuring the perturbation of some property of a reactant molecule due to the presence of nearby donors or acceptors. For instance, the optical spectra of the intermediate acceptor A_1 (Chl, BChl, Ph, or Bph) in RCs show changes (generally referred to as electrochromic shifts) due to the reduction of the primary acceptor A_2 (quinones, Fe-S centers, etc.) (see Figs. 15a, 25, and 34). Perturbations of the ESR spectra were also observed. For instance, the ESR spectrum of the reduced intermediate acceptor (A_1^-) in both bacterial and PSII RC complexes exhibits a splitting due to interaction with the nearby reduced primary acceptor (A_2^-) (see Figs. 13 and 33). The same interactions that give rise to spectroscopic perturbations are also responsible for electron transfer between the two reactants (see Hopfield, 1974; Okamura *et al.*, 1979b). Thus, from a measurement of the electron transfer rate, a distance can be estimated (Hopfield, 1979). The distances obtained from these approaches depend critically on the theoretical models; they should be considered at present only as estimates to be reviewed and refined as new theories are developed.

The role of the RC protein is to provide both an appropriate chemical environment for the primary reactants and a framework for their structural organization. For example, it may be essential to shield the primary reactants from contact with exogenous donors and acceptors and to provide an environment for their proper functioning, e.g., by providing appropriate ligands or hydrophobic groups in the pocket around the reactant molecule. As a consequence, some of the chemistry that takes place within the RCs is rather unusual. For instance, in bacterial RCs, the

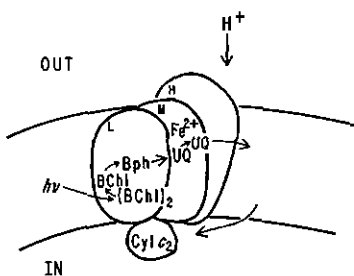

FIG. 35. Schematic representation of a proposed structure of RC from the purple bacteria (*Rp. sphaeroides*), the position of the bound Cyt c_2 (absent in purified RCs) is also indicated. The labeling "in and out" refers to chromatophores (for the plasma membrane the labeling should be reversed).

3, this volume). Electrons transfer back across the membrane to the PSI donor through an electron transfer chain (not shown in Fig. 36) containing quinone, Cyt *b*, Rieske Fe-S center, Cyt *f*, and plastocyanin. The role of Cyt *b*₅₅₉ is not clear yet. Protons are pumped into the thylakoid membrane in this process. The PSI RC is shown as a dimer of the 70 kD subunits containing P700 [labeled (Chl)] and a Chl acceptor. The location of other acceptors, X, Fe-S-B and -A (i.e., A_{I,1}, A_{I,2}, A_{I,3}) are not definitively known. In Fig. 36, they are shown on separate subunits, although several of them may be on the same subunit. The interaction of the RC with plastocyanin is shown to be mediated through subunit III.

One common feature of all RC complexes is that several (~4-5) electron transfer components are used to separate the oxidized and reduced species (the electron-hole pair), by a large distance ($R > 20 \text{ \AA}$, see, e.g., Hopfield, 1979). This stratagem results in a fast removal of the charges thereby preventing wasteful charge recombinations by back reactions (Parson and Ke, Chapter 8, this volume). The reason why a series of small electron transfer steps produces a much faster transfer rate across a given distance R than a single large step is intimately connected with the mechanism of charge transfer. It is believed that electron tunneling is responsible for this process. (For a review on tunneling, see DeVault, 1980.) According to current theories the rate of electron transfer, k , by this mechanism decreases exponentially with distance (Hopfield, 1974; Jortner, 1976):

$$k \cong e^{-\alpha R} \quad (1)$$

where α is a parameter that has been estimated to be about 2 \AA^{-1} .

Consider now the rate of electron transfer over a distance R for two cases: (a) two reactants, D, A, separated by a distance R , and (b) three reactants, D,I,A, with the reactant I situated half way ($R/2$) between D and A. Using relation (1) the ratio of rates of electron transfer for case b and case a is given by

$$\frac{k(D \rightarrow I \rightarrow A)}{k(D \rightarrow A)} \cong \frac{1}{2} e^{\alpha R/2}$$

For $R = 20 \text{ \AA}$, this corresponds to a factor of 2.5×10^8 in rate. If instead of one acceptor, two intermediates are equidistantly interposed, the increase in rate is $\sim 10^{11}$. After charge separation has occurred, the direct electron transfer reaction from A to D (i.e., dark recombination) is slowed down by the large distance separating these two components.

One can understand the similarities between RCs from bacteria and green plants in terms of a possible scenario of the evolutionary development (Olson, 1978; Prince and Dutton, 1978a,b). (Also, see discussions in Chapter 2 by Wraight, this volume.) It has been proposed that all

organisms that utilize membrane bound electron transfer chains, including photosynthetic bacteria and green plants, arose from a common ancestry (Dickerson, 1980). The most primitive species were likely to have been photosynthetic microorganisms, which utilized a single RC that either reduced CO_2 using H_2S as a donor (green bacteria) or drove cyclic electron transport through a proton pumping electron transfer chain capable of synthesizing ATP (purple bacteria). The present-day green plant photosynthetic apparatus could have arisen from a merger of two primitive bacterial RC complexes. Photosystem II could have developed from a primitive (similar to the one of purple bacteria) RC after modifying the redox potential of its donor to allow it to oxidize water. PSI could have come from a primitive RC, like that of green bacteria. The electron transfer chain connecting PSII and PSI could have arisen from the proton pumping chains of purple bacteria (Fig. 37).

The green plant photosynthetic apparatus, which has evolved, has the great advantage over more primitive photosynthetic organisms in its ability to utilize ubiquitous H_2O as an electron donor rather than H_2S . Although H_2S is likely to have been plentiful in the reducing atmosphere, it is presently only found in a few ecological niches. A second important feature of the green plant photosynthetic apparatus is its ability to produce ATP by photophosphorylation in addition to NADPH. This is important since CO_2 reduction to carbohydrate requires a lower potential reductant than NADPH. Consequently, CO_2 fixation via the reductive pentose phosphate cycle requires both ATP and NADPH (see Arnon, 1977).

Dickerson (1980) proposed an evolutionary scheme in which the present-day respiratory chain arose from the electron transfer chain of photosynthetic bacteria. Since the counterpart of the RC in the respiratory chain is Cyt oxidase (both oxidize Cyt *c*), it is interesting to note that there are some striking similarities between RCs and Cyt oxidase. A bacterial Cyt oxidase isolated by Ludwig and Schatz (1980) contains two

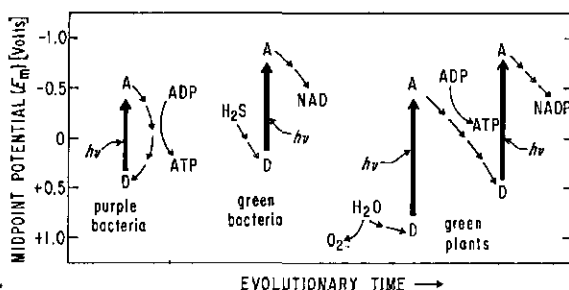

FIG. 37. A possible scheme for the evolutionary development of two photosystems in green plants through the merger of two primitive bacterial RCs.

subunits (45 and 28 kD) similar to that of RCs. The amino acid composition of the larger Cyt oxidase subunit I is very similar to that of the L-M unit from bacterial RCs indicating a close homology between the two (see Appendix). Cytochrome oxidase as well as RCs from bacteria, PSI and PSII aggregate when heated in SDS which may be indicative of structural similarity. It is tempting to speculate that Cyt oxidase which contains two heme *a* molecules, perhaps analogous to the BChl dimer in the primary donor, could have arisen from a primitive RC.

In conclusion, studies of RCs from diverse organisms have shown them to have many common features. Further studies of RCs should advance our understanding of the basic mechanism of photosynthetic electron transfer processes as well as the evolutionary chain of events.

V. Appendix

Lacking sufficient information on the primary sequence of RCs, we shall examine the amino acid compositions of RCs and related proteins to determine the extent of their similarity. A quantitative index of the similarity between the amino acid compositions of two different proteins is the compositional divergence index *d* (Harris and Teller, 1973) which is defined as

$$d = \sqrt{\sum_{i=1}^N (X_{ai} - X_{bi})^2}$$

where X_{ai} and X_{bi} are the mole fractions of amino acid *i* in proteins *a* and *b*, respectively, and *N* is the number of different kinds of amino acids measured. The values of *d* for a number of different pairs of proteins including membrane proteins is given in Table V.

The values of *d* range from 0.02 to >0.16 depending upon the similarity between the proteins compared. The lower limit is set by the accuracy of the amino acid analysis. The values of *d* appear to fall into several ranges.

d	
0.01–0.03	Identical proteins (error due to analysis)
0.03–0.05	Closely related proteins
0.05–0.06	Distantly related proteins
0.06–0.10	Unrelated similar proteins (i.e., membrane protein compared to another membrane protein)
> 0.10	Dissimilar proteins (i.e., membrane protein compared to water soluble protein)

TABLE V
The Compositional Divergence between Various Pairs of Proteins^{a,b}

Proteins compared	d
RC ¹ (<i>Rs. rubrum</i> G-9)—RC ² (<i>Rs. rubrum</i> S-1)	0.021
RC ¹ (<i>Rp. sphaeroides</i> R-26)—RC ² (<i>Rs. rubrum</i> S-1)	0.028
ATPase ³ (bovine)—ATPase ³ (<i>S. fecalis</i>)	0.033
RC ⁴ subunit L (<i>Rp. sphaeroides</i>)—RC subunit γ^2 (<i>Rs. rubrum</i>)	0.039
RC subunit M ⁴ (<i>Rp. sphaeroides</i>)—RC subunit β^2 (<i>Rs. rubrum</i>)	0.043
RC subunit H ⁴ (<i>Rp. sphaeroides</i>)—RC subunit α^2 (<i>Rs. rubrum</i>)	0.060
P700 RC ⁵ (swiss chard)—P700 Chl <i>a</i> protein ⁶ (spinach)	0.036
RC ¹ (<i>Rp. sphaeroides</i>)—P700 RC ⁵ (swiss chard)	0.041
RC ¹ (<i>Rp. sphaeroides</i>)—P700 Chl <i>a</i> protein ⁶ (spinach)	0.048
RC subunit L—M ⁴ (<i>Rp. sphaeroides</i>)—cytochrome oxidase subunit I ⁷ (<i>Paracoccus denitrificans</i>)	0.040
RC subunit H ⁴ (<i>Rp. sphaeroides</i>)—cytochrome oxidase subunit II ⁷ (<i>Paracoccus denitrificans</i>)	0.068
RC subunit L ⁴ (<i>Rp. sphaeroides</i>)—RC subunit M ⁴ (<i>Rp. sphaeroides</i>)	0.047
RC subunit L ⁴ (<i>Rp. sphaeroides</i>)—RC subunit H ⁴ (<i>Rp. sphaeroides</i>)	0.096
RC subunit M ⁴ (<i>Rp. sphaeroides</i>)—RC subunit H ⁴ (<i>Rp. sphaeroides</i>)	0.084
RC ¹ (<i>Rp. sphaeroides</i>)—Rhodopsin ³ (bovine)	0.075
RC ¹ (<i>Rp. sphaeroides</i>)—Erythrocyte membrane protein ³ (human)	0.091
RC ¹ (<i>Rp. sphaeroides</i>)—Plasma membrane protein ³ (rat liver)	0.081
RC ¹ (<i>Rp. sphaeroides</i>)—Chymotrypsinogen ⁸ (bovine)	0.126
RC ¹ (<i>Rp. sphaeroides</i>)—B. lactoglobulin ⁸ (bovine)	0.161
RBC ³ protein—Rhodopsin ³ (bovine)	0.077
Myelin Proteolipid ³ —Rhodopsin ³ (bovine)	0.083
Myelin Proteolipid ³ —RBC protein ³	0.100
RBC Protein ³ —ATPase F ₁ ³ (bovine)	0.073

^aSixteen amino acids were used (tryptophan and cysteine were excluded).

^bReferences: ¹Steiner *et al.* (1974a); ²Vadeboncoeur *et al.* (1979a); ³Steck and Fox (1972); ⁴Rosen *et al.* (see Table II); ⁵Nelson and Notsani (1977); ⁶Thornber *et al.* (1977); ⁷Ludwig and Schatz (1980); ⁸Lehninger (1975).

Although the preceding assignments represent only a rough guide to protein homology, it is significant that values of *d* less than 0.05 are obtained only for proteins that are known or expected to be related. Although two *related* proteins may have a high compositional divergence due to divergent evolution, the probability that two *unrelated* proteins will by chance have a low compositional divergence index is small since this would require a fortuitous convergence to a common composition.

Examination of the compositional divergence index for various pairs of proteins listed in Table V reveals some interesting relationships.

1. The bacterial RC from *Rp. sphaeroides* and *Rs. rubrum* are similar (*d* = 0.028). The L and M subunits from both species are also similar (*d* = 0.039 and 0.043 for L and M, respectively). The

composition of the H subunit from the two species is more variable ($d = 0.060$). The L subunit from *Rp. sphaeroides* is very similar to the M subunit ($d = 0.047$); this may indicate a common origin for the two proteins.

2. The P700 RC preparation from swiss chard is similar to the P700 Chl *a* protein from spinach ($d = 0.036$).
3. The bacterial RC from *Rp. sphaeroides* is similar to both the P700 RC complex from swiss chard ($d = 0.041$) and the P700 Chl *a* protein from spinach ($d = 0.048$).
4. The active unit (LM) from the bacterial RC from *Rp. sphaeroides* is related to the subunit I of Cyt oxidase from *Paracoccus denitrificans* ($d = 0.040$).

These tentative relationships based on amino acid composition indicate interesting possible protein homologies. Further analyses of the sequences of these proteins is needed to obtain further information about their relationships.

Acknowledgments

We thank the many researchers who supplied us with reprints and preprints and R. Debus, P. Eisenberger, R. Isaacson, D. Rosen, L. A. Steiner, and G. Valkirs for their permission to quote their unpublished results. The work from the laboratory of M. Okamura and G. Feher described in this chapter was supported by grants from the National Science Foundation and by National Institutes of Health.

REFERENCES

- Agalidis, I., Lutz, M., and Reiss-Husson, F. (1980). *Biochim. Biophys. Acta* **589**, 264–274.
- Amesz, J., and Duysens, L. N. M. (1977). *Top. Photosynth.* **2**, 149–186.
- Anderson, J. M., and Boardman, N. K. (1966). *Biochim. Biophys. Acta* **112**, 403–421.
- Arnold, W., and Clayton, R. K. (1960). *Proc. Natl. Acad. Sci. U.S.A.* **46**, 769–776.
- Arnon, D. I. (1977). *Encycl. Plant Physiol., New Ser.* **3**, 7–58.
- Avron, M. (1967). *Curr. Top. Bioenerg.* **2**, 1–22.
- Baltimore, B. G., and Malkin, R. (1980a). *Photochem. Photobiol.* **31**, 485–490.
- Baltimore, B. G., and Malkin, R. (1980b). *FEBS Lett.* **110**, 50–52.
- Bar-Nun, S., Schantz, R., and Ohad, I. (1977). *Biochim. Biophys. Acta* **459**, 451–467.
- Bartsch, R. G. (1978). In "The Photosynthetic Bacteria" (R. K. Clayton and W. R. Sistrom, eds.), pp. 249–280. Plenum, New York.
- Bengis, C., and Nelson, N. (1975). *J. Biol. Chem.* **250**, 2783–2788.
- Bengis, C., and Nelson, N. (1977). *J. Biol. Chem.* **252**, 4564–4569.
- Bensasson, R., and Land, E. J. (1973). *Biochim. Biophys. Acta* **325**, 175–181.
- Blankenship, R. E., and Parson, W. W. (1978). *Annu. Rev. Biochem.* **47**, 635–653.
- Blankenship, R. E., and Parson, W. W. (1979). *Biochim. Biophys. Acta* **545**, 429–444.

- Blankenship, R. E., McQuire, A., and Sauer, K. (1975). *Proc. Natl. Acad. Sci. U.S.A.* **72**, 4943-4947.
- Boardman, N. K. (1968). *Adv. Enzymol.* **30**, 1-79.
- Boardman, N. K., and Anderson, I. M. (1964). *Nature (London)* **203**, 166-167.
- Boardman, N. K., and Anderson, J. M. (1967). *Biochim. Biophys. Acta* **143**, 187-203.
- Boardman, N. I., Anderson, J. M., and Goodchild, D. J. (1978). *Curr. Top. Bioenerg.* **7**, 75-138.
- Bolton, J. R. (1977). *Top. Photosynth.* **2**, 187-202.
- Bolton, J. R., Clayton, R. K., and Reed, D. W. (1969). *Photochem. Photobiol.* **9**, 209-218.
- Boucher, F., van der Rest, M., and Gingras, G. (1977). *Biochim. Biophys. Acta* **461**, 339-357.
- Boso, B., Debrunner, P., Okamura, M. Y., and Feher, G. (1981). *Biochim. Biophys. Acta* **638**, 173-177.
- Bouges-Bocquet, B. (1973). *Biochim. Biophys. Acta* **314**, 250-256.
- Bouges-Bocquet, B., and Delosme, R. (1978). *FEBS Lett.* **94**, 100-104.
- Bowman, M. K., Norris, J. R., and Wraight, C. A. (1979). *Biophys. J.* **25**, 203a.
- Boxer, S., and Closs, G. L. (1976). *J. Am. Chem. Soc.* **98**, 5406-5408.
- Briantais, J. M. (1969). Doctoral Thesis, University of Paris at Orsay, France.
- Brogie, R. M., Hunter, C. N., Delepelaire, P., Niederman, R. A., Chua, N.-H., and Clayton, R. K. (1980). *Proc. Natl. Acad. Sci. U.S.A.* **77**, 87-91.
- Brudvig, G. W., Worland, S. T., and Sauer, K. (1982). *Biophys. J.* **37**, 222a.
- Bunker, G., Stern, E. A., Blankenship, R. E., and Parson, W. W. (1982). *Biophys. J.* **37**, 539-551.
- Butler, W. F., Johnston, D. C., Shore, H. B., Fredkin, D. R., Okamura, M. Y., and Feher, G. (1980). *Biophys. J.* **32**, 967-992.
- Cammack, R., and Evans, M. C. W. (1975). *Biochem. Biophys. Res. Commun.* **67**, 544-549.
- Chua, N.-H., and Bennoun, P. (1975). *Proc. Natl. Acad. Sci. U.S.A.* **72**, 2175-2179.
- Chua, N.-H., Matlin, K., and Bennoun, P. (1975). *J. Cell Biol.* **67**, 361-377.
- Clarke, R. H., Connors, R. E., Frank, H. A., and Hoch, J. C. (1977). *Chem. Phys. Lett.* **45**, 523-528.
- Clayton, B. J., and Clayton, R. K. (1978). *Biochim. Biophys. Acta* **501**, 470-477.
- Clayton, R. K., and Clayton, B. J. (1978). *Biochim. Biophys. Acta* **501**, 478-487.
- Clayton, R. K., and Haselkorn, R. (1972). *J. Mol. Biol.* **68**, 97-105.
- Clayton, R. K., and Sistrom, W. R., eds. (1978). "The Photosynthetic Bacteria." Plenum, New York.
- Clayton, R. K., and Straley, S. C. (1970). *Biochem. Biophys. Res. Commun.* **39**, 1114-1119.
- Clayton, R. K., and Wang, R. T. (1971). In "Methods in Enzymology" (A. San Pietro, ed.), Vol. 23, pp. 696-704. Academic Press, New York.
- Clayton, R. K., and Yamamoto, T. (1976). *Photochem. Photobiol.* **24**, 67-70.
- Cogdell, R. J., Bruze, D. C., and Clayton, R. C. (1974). *FEBS Lett.* **45**, 344-347.
- Cogdell, R. J., Parson, W. W., and Kerr, M. A. (1976). *Biochem. Biophys. Acta* **430**, 83-93.
- Commoner, B., Heise, J. J., and Townsend, J. (1956). *Proc. Natl. Acad. Sci. U.S.A.* **42**, 710-718.
- Cramer, W. A., and Butler, W. L. (1969). *Biochim. Biophys. Acta* **172**, 503-510.
- Crofts, A. R., Crowther, D., Celis, H., Almanza de Celis, S., and Tierney, G. (1977). *Biochem. Soc. Trans.* **5**, 491-495.
- Croze, E., Kelley, M., and Horton, P. (1979). *FEBS Lett.* **103**, 22-26.
- Darszon, A., Vandenberg, C. A., Schonfield, M., Ellisman, M. H., Spitzer, N. C., and Montal, M. (1980). *Proc. Natl. Acad. Sci. U.S.A.* **77**, 239-243.
- Davis, M. S., Forman, A., Hanson, L. K., Thornber, J. P., and Fajer, J. (1979a). *J. Phys. Chem.* **83**, 3325-3332.

- Davis, M. S., Forman, A., and Fajer, J. (1979b). *Proc. Natl. Acad. Sci. U.S.A.* **76**, 4170-4174.
- Debrunner, P. G., Schulz, C. E., Feher, G., and Okamura, M. Y. (1975). *Biophys. Soc. Abstr.* **15**, 226.
- Debus, R., Okamura, M. Y., and Feher, G. (1981). *Biophys. J.* **33**, 19a.
- Debus, R., Valkirs, G., Okamura, M. Y., and Feher, G. (1982). *Biochim. Biophys. Acta* submitted.
- Delepelaire, P., and Chua, N.-H. (1979). *Proc. Natl. Acad. Sci. U.S.A.* **76**, 111-115.
- DeVault, D. (1980). *Q. Rev. Biol.* **13**, 387-564.
- DeVault, D., and Chance, B. (1966). *Biophys. J.* **6**, 825-847.
- Dickerson, R. E. (1980). *Sci. Am.* **242**, 137-153.
- Dietrich, W. E., and Thornber, J. P. (1971). *Biochim. Biophys. Acta* **245**, 482-493.
- Döring, G., Renger, G., Vater, J., and Witt, H. T. (1969). *Z. Naturforsch., B: Anorg. Chem., Org. Chem., Biochem., Biophys., Biol.* **24B**, 1139-1143.
- Dörnemann, D., and Senger, H. "Photosynthesis" (G. Akoyunoglou, ed.), Vol. 5, pp. 223-231. Balaban Int. Sci. Services, Philadelphia.
- Drachev, L. A., Frolov, V. N., Kaulen, A. D., Kondrashin, A. A., Samuilov, V. D., Semenov, A. Yu., and Skulachev, V. P. (1976). *Biochim. Biophys. Acta* **440**, 637-660.
- Dutton, P. L., and Prince, R. C. (1978). In "The Photosynthetic Bacteria" (R. K. Clayton and W. R. Sistrom, eds.), pp. 525-570. Plenum, New York.
- Dutton, P. L., Leigh, J. S., and Seibert, M. (1972). *Biochem. Biophys. Res. Commun.* **46**, 406-413.
- Dutton, P. L., Leigh, J. S., and Reed, D. W. (1973). *Biochim. Biophys. Acta* **292**, 654-664.
- Dutton, P. L., Prince, R. C., Tiede, D. M., Petty, K. M., Kaufmann, J. K., Netzel, and Rentzepis, P. M. (1977). *Brookhaven Symp. Biol.* **28**, 213-236.
- Duysens, L. N. M. (1952). Thesis, University of Utrecht, The Netherlands.
- Duysens, L. N. M., and Sweers, H. E. (1963). In "Studies on Microalgae and Photosynthetic Bacteria" (Jpn. Soc. Plant Physiol., ed.), pp. 353-372. Univ. of Tokyo Press, Tokyo.
- Eisenberger, P. M., Okamura, M. Y., and Feher, G. (1979). In "Sixth Annual Stanford Synchrotron Radiation Lab Users' Group Meeting," SSRL Rep. No. 79/05, p. 88. Stanford University, Stanford, California.
- Eisenberger, P. M., Okamura, M. Y., and Feher, G. (1980). *Fed. Proc., Fed. Am. Soc. Exp. Biol.* **39**, 1802.
- Eisenberger, P. M., Okamura, M. Y., and Feher, G. (1982). *Biophys. J.* **37**, 523-538.
- Emerson, R., and Arnold, W. (1932). *J. Gen. Physiol.* **16**, 191-205.
- Evans, E. H., Cammack, R., and Evans, M. C. W. (1976). *Biochem. Biophys. Res. Commun.* **68**, 1212-1218.
- Evans, M. C. W., Reeves, S. G., and Cammack, R. (1974). *FEBS Lett.* **49**, 111-114.
- Evans, M. W. C., Sihra, C. K., Bolton, J. R., and Cammack, R. (1975). *Nature (London)* **256**, 668-670.
- Evans, M. C. W., Sihra, C. K., and Cammack, R. (1976). *Biochem. J.* **158**, 71-77.
- Evans, M. C. W., Sihra, C. K., and Slabas, A. R. (1977). *Biochem. J.* **162**, 75-85.
- Fajer, J., Brune, D. C., Davis, M. S., Forman, A., and Spaulding, L. D. (1975). *Proc. Natl. Acad. Sci. U.S.A.* **72**, 4956-4960.
- Fajer, J., Davis, M. S., Brune, D. C., Spaulding, L. D., Borg, D. C., and Forman, A. (1977). *Brookhaven Symp. Biol.* **28**, 74-103.
- Feher, G. (1971). *Photochem. Photobiol.* **14**, 373-387.
- Feher, G., and Okamura, M. Y. (1977). *Brookhaven Symp. Biol.* **28**, 183-194.
- Feher, G., and Okamura, M. Y. (1978). In "The Photosynthetic Bacteria" (R. K. Clayton and W. R. Sistrom, eds.), pp. 349-386. Plenum, New York.
- Feher, G., Okamura, M. Y., and McElroy, J. D. (1972). *Biochim. Biophys. Acta* **267**, 222-226.
- Feher, G., Hoff, A. J., Isaacson, R. A., and McElroy, J. D. (1973). *Biophys. J.* **13**, 61 (abstr.).

- Feher, G., Isaacson, R. A., McElroy, J. D., Ackerson, L. C., and Okamura, M. Y. (1974). *Biochim. Biophys. Acta* **368**, 135-139.
- Feher, G., Hoff, A. J., Isaacson, R. A., and Ackerson, L. C. (1975). *Ann. N.Y. Acad. Sci.* **244**, 239-259.
- Feher, G., Isaacson, R. A., and Okamura, M. Y. (1977). *Biophys. J.* **17**, 149 (abstr.).
- Fenton, J. M., Pellin, M. J., Govindjee, and Kaufmann, K. J. (1979). *FEBS Lett.* **100**, 1-4.
- Fong, F. K. (1974). *Proc. Natl. Acad. Sci. U.S.A.* **71**, 3692-3695.
- Frank, H. A., McLean, M. B., and Sauer, K. (1979). *Proc. Natl. Acad. Sci. U.S.A.* **76**, 5124-5128.
- Friesner, R., Dismukes, G. C., and Sauer, K. (1979). *Biophys. J.* **21**, 239-256.
- Fuhrhop, J. H., and Mauzerall, D. (1969). *J. Am. Chem. Soc.* **91**, 4174-4181.
- Fujita, I., Davis, M. S., and Fajer, J. (1978). *J. Am. Chem. Soc.* **100**, 6280-6282.
- Gaffron, H., and Wohl, K. (1936). *Naturwissenschaften* **24**, 81-107.
- Garcia, A., Drews, G., and Kamen, M. D. (1974). *Proc. Natl. Acad. Sci. U.S.A.* **71**, 4213-4216.
- Gast, P., and Hoff, A. J. (1979). *Biochim. Biophys. Acta* **548**, 520-535.
- Gingras, G. (1978). In "The Photosynthetic Bacteria" (R. K. Clayton and W. R. Sistrom, eds.), pp. 119-131. Plenum, New York.
- Gingras, G., and Jolchine, G. (1969). *Prog. Photosynth. Res., Proc. Int. Congr. [1st], 1968*, Vol. 1, pp. 209-216.
- Golbeck, J. H., and Kok, B. (1978). *Arch. Biochem. Biophys.* **188**, 233-242.
- Golbeck, J. H., Lien, S., and San Pietro, A. (1977). *Arch. Biochem. Biophys.* **178**, 140-150.
- Govindjee, and Govindjee, R. (1975). In "Bioenergetics of Photosynthesis" (Govindjee, ed.), pp. 1-50. Academic Press, New York.
- Haehnel, W., Hesse, V., and Pröpper, A. (1980). *FEBS Lett.* **111**, 79-82.
- Hall, R. L., Chu Kung, M., Fu, M., Hales, B. J., and Loach, P. A. (1973). *Photochem. Photobiol.* **18**, 505-520.
- Hall, R. L., Doorley, P. F., and Niederman, R. A. (1978). *Photochem. Photobiol.* **28**, 273-276.
- Halsey, Y. D., and Byers, B. (1975). *Biochim. Biophys. Acta* **387**, 349-367.
- Halsey, Y. D., and Parson, W. W. (1974). *Biochim. Biophys. Acta* **347**, 404-416.
- Harris, C. E., and Teller, D. C. (1973). *J. Theor. Biol.* **38**, 347-362.
- Hauska, G., Samoray, D., Orlich, G., and Nelson, N. (1980). *Eur. J. Biochem.* **111**, 535-543.
- Heathcote, P., and Evans, M. C. W. (1980). *FEBS Lett.* **111**, 381-385.
- Heathcote, P., Williams-Smith, D. L., and Evans, M. C. W. (1978). *Biochem. J.* **170**, 373-378.
- Heathcote, P., Timofeev, K. N., and Evans, M. C. W. (1979). *FEBS Lett.* **101**, 105-109.
- Hiyama, T., and Ke, B. (1971). *Arch. Biochem. Biophys.* **147**, 99-108.
- Hoch, G. (1977). *Encycl. Plant Physiol., New Ser.* **5**, 136-146.
- Hoff, A. J. (1979). *Phys. Rep.* **54**, 75-200.
- Holten, D., Windsor, M. W., Parson, W. W., and Thornber, J. P. (1978). *Biochim. Biophys. Acta* **501**, 112-126.
- Hopfield, J. J. (1974). *Proc. Natl. Acad. Sci. U.S.A.* **71**, 3640-3644.
- Hopfield, J. J. (1979). In "Tunneling in Biological Systems" (B. Chance, D. DeVault, H. Frauenfelder, R. A. Marcus, J. R. Schrieffer, and N. Sutin, eds.), pp. 417-430. Academic Press, New York.
- Horton, P., and Croze, E. (1979). *Biochim. Biophys. Acta* **545**, 188-201.
- Ikegami, J., and Katoh, S. (1975). *Biochim. Biophys. Acta* **376**, 588-592.
- Izawa, S. (1977). *Encycl. Plant Physiol., New Ser.* **5**, 266-282.
- Jennings, J. V., and Evans, M. C. W. (1976). *Proc. Bacterial Photosynth. Conf., 1976* Abstract No. MB3.
- Jolchine, G., and Reiss-Husson, F. (1974). *FEBS Lett.* **40**, 5-8.

- Jolchine, G., and Reiss-Husson, F. (1975). *FEBS Lett.* **52**, 33–36.
- Jortner, J. J. (1976). *J. Chem. Phys.* **64**, 4860–4867.
- Junge, W., Schaffernicht, H., and Nelson, N. (1977). *Biochim. Biophys. Acta* **462**, 73–85.
- Jursinic, P., and Govindjee (1977). *Photochem. Photobiol.* **26**, 617–628.
- Katz, J. J., Norris, J. R., Shipman, L. L., Thurnauer, M. C., and Wasielewski, M. R. (1978). *Annu. Rev. Biophys. Bioeng.* **7**, 393–434.
- Ke, B. (1973). *Biochim. Biophys. Acta* **301**, 1–33.
- Ke, B. (1978). *Curr. Top. Bioenerg.* **7**, 75–138.
- Ke, B., and Dolan, E. (1980). *Biochim. Biophys. Acta* **590**, 401–406.
- Ke, B., Hansen, R. E., and Beinert, H. (1973a). *Proc. Natl. Acad. Sci. U.S.A.* **70**, 2941–2945.
- Ke, B., Sahu, S., Shaw, E., and Beinert, H. (1973b). *Biochim. Biophys. Acta* **347**, 36–48.
- Ke, B., Sugahara, K., and Shaw, E. R. (1975). *Biochim. Biophys. Acta* **408**, 12–25.
- Ke, B., Dolan, E., Sugahara, K., Hawkrige, F. M., Demeter, S., and Shaw, E. R. (1977). *Plant Cell Physiol., Spec. Issue* **3**, 187–199.
- Klimov, V. V., Klevanik, A. V., Shuvalov, V. A., and Krasnovsky, A. A. (1977a). *FEBS Lett.* **82**, 183–186.
- Klimov, V. V., Shuvalov, V. A., Krakhmaleva, I. N., Klevanik, A. V., and Krasnovsky, A. A. (1977b). *Biokhimiya* **42**, 519–530.
- Klimov, V. V., Allakhverdiev, S. I., Demeter, S., and Krasnovsky, A. A. (1979). *Dokl. Akad. Nauk SSSR* **249**, 227–230.
- Klimov, V. V., Allakhverdiev, S. I., and Krasnovsky, A. A. (1980a). *Dokl. Akad. Nauk SSSR* **249**, 485–488.
- Klimov, V. V., Dolan, E., and Ke, B. (1980b). *FEBS Lett.* **112**, 97–100.
- Klimov, V. V., Dolan, E., Shaw, E. R., and Ke, B. (1980c). *Proc. Natl. Acad. Sci. U.S.A.* **77**, 7227–7231.
- Knaff, D. B. (1978). In "The Photosynthetic Bacteria" (R. K. Clayton and W. R. Sistrom, eds.), Chapter 32, pp. 629–640. Plenum, New York.
- Knaff, D. B., and Malkin, R. (1973). *Arch. Biochem. Biophys.* **159**, 555–562.
- Knaff, D. B., and Malkin, R. (1976). *Biochim. Biophys. Acta* **430**, 244–252.
- Knaff, D. B., Malkin, R., Myron, J. C., and Stoller, M. (1977). *Biochim. Biophys. Acta* **459**, 402–411.
- Kok, B. (1956). *Biochim. Biophys. Acta* **22**, 399–401.
- Kok, B. (1961). *Biochim. Biophys. Acta* **48**, 527–533.
- Lehninger, A. L. (1975). "Biochemistry," p. 101. Worth Publ., New York.
- Leigh, J. S., and Dutton, P. L. (1972). *Biochem. Biophys. Res. Commun.* **46**, 414–421.
- Leigh, J. S., and Dutton, P. L. (1974). *Biochim. Biophys. Acta* **357**, 67–77.
- Lin, L., and Thornber, J. P. (1975). *Photochem. Photobiol.* **22**, 37–40.
- Loach, P. A. (1976). *Prog. Bioorg. Chem.* **4**, 89–192.
- Loach, P. A., and Hall, R. L. (1972). *Proc. Natl. Acad. Sci. U.S.A.* **69**, 786–790.
- Loach, P. A., Kung, M., and Hales, B. J. (1975). *Ann. N.Y. Acad. Sci.* **244**, 297–319.
- Ludwig, B., and Schatz, G. (1980). *Proc. Natl. Acad. Sci. U.S.A.* **77**, 196–200.
- Lutz, M., and Kleo, J. (1979). *Biochim. Biophys. Acta* **546**, 365–369.
- Lutz, M., Kleo, J., and Reiss-Husson, F. (1976). *Biochem. Biophys. Res. Commun.* **69**, 711–717.
- Lutz, M., Agalidis, I., Hervo, G., Cogdell, R. J., and Reiss-Husson, F. (1978). *Biochim. Biophys. Acta* **503**, 287–303.
- McElroy, J. D., Feher, G., and Mauzerall, D. (1970). *Biophys. Soc. Abstr.* **10**, 204.
- McElroy, J. D., Feher, G., and Mauzerall, D. C. (1972). *Biochim. Biophys. Acta* **267**, 363–374.
- McElroy, J. D., Mauzerall, D. C., and Feher, G. (1974). *Biochim. Biophys. Acta* **333**, 261–278.
- Machold, O. (1975). *Biochim. Biophys. Acta* **382**, 494–505.
- McIntosh, A. R., Chu, M., and Bolton, J. R. (1975). *Biochim. Biophys. Acta* **376**, 308–314.
- Malkin, R., and Bearden, A. J. (1971). *Proc. Natl. Acad. Sci. U.S.A.* **68**, 16–19.

- Malkin, R., and Bearden, A. J. (1975). *Biochem. Biophys. Acta* **396**, 250–251.
- Malkin, R., and Bearden, A. J. (1978). *Biochim. Biophys. Acta* **505**, 147–182.
- Malkin, R., Bearden, A. J., Hunter, F. A., Alberte, R. S., and Thornber, J. P. (1976). *Biochim. Biophys. Acta* **430**, 389–394.
- Marinetti, T. D., Okamura, M. Y., and Feher, G. (1979). *Biochemistry* **18**, 3126–3133.
- Mathis, P., and Vermeglio, A. (1975). *Biochim. Biophys. Acta* **396**, 371–381.
- Mathis, P., Havemen, J., and Yates, M. (1977). *Brookhaven Symp. Biol.* **28**, 267–276.
- Mathis, P., Sauer, K., and Remy, R. (1978). *FEBS Lett.* **88**, 275–278.
- Mauzerall, D. (1978). In "The Photosynthetic Bacteria" (R. K. Clayton and W. R. Sistrom, eds.), pp. 223–231. Plenum, New York.
- Mitchell, P. (1966). *Biol. Rev. Cambridge Philos. Soc.* **41**, 445–502.
- Morrison, L., Runquist, J., and Loach, P. (1977). *Photochem. Photobiol.* **25**, 73–84.
- Moskalenko, A. A., and Erokhin, Yu, E. (1974). *Microbiologia* **43**, 556–559.
- Moskowitz, E., and Malley, M. M. (1978). *Photochem. Photobiol.* **27**, 55–59.
- Mullet, J. E., Burke, J. J., and Arntzen, C. J. (1980). *Plant Physiol.* **65**, 814–822.
- Nelson, N., and Bengis, C. (1975). *Proc. Int. Congr. Photosynth., 3rd, 1974*, pp. 609–620.
- Nelson, N., and Hauska, G. (1979). In "Membrane Bioenergetics" (C. P. Lee, G. Schatz, and L. Ernster, eds.), pp. 189–202. Addison-Wesley, Reading, Massachusetts.
- Nelson, N., and Neumann, J. (1972). *J. Biol. Chem.* **247**, 1817–1824.
- Nelson, N., and Notsani, B. (1977). *Dev. Bioen. Biomembr.* **1**, 233–244.
- Nelson, N., and Racker, E. (1972). *J. Biol. Chem.* **247**, 3848–3853.
- Nelson, N., Bengis, C., Silver, B. L., Getz, D., and Evans, M. C. W. (1975). *FEBS Lett.* **58**, 363–365.
- Netzel, T. L., Rentzepis, P. M., and Leigh, J. (1973). *Science* **182**, 238–241.
- Nieth, K. F., Drews, G., and Feick, R. (1975). *Arch. Microbiol.* **105**, 43–45.
- Noël, H., van der Rest, M., and Gingras, G. (1972). *Biochim. Biophys. Acta* **275**, 219–230.
- Norris, J. R., Uphaus, R. A., Crespi, H. L., and Katz, J. J. (1971). *Proc. Natl. Acad. Sci. U.S.A.* **68**, 625–629.
- Norris, J. R., Druyan, M. E., and Katz, J. J. (1973). *J. Am. Chem. Soc.* **95**, 1680–1682.
- Norris, J. R., Scheer, H., Druyan, M. E., and Katz, J. J. (1974). *Proc. Natl. Acad. Sci. U.S.A.* **71**, 4897–4900.
- Norris, J. R., Scheer, H., and Katz, J. J. (1975). *Ann. N.Y. Acad. Sci.* **244**, 261–280.
- Nugent, J. H. A., Diner, B. A., and Evans, M. C. W. (1981). *FEBS Lett.* **124**, 241–244.
- Odermatt, E., Snozzi, M., and Bachofen, R. (1980). *Biochim. Biophys. Acta* **591**, 372–381.
- Oettmeier, W., and Grewe, R. (1974). *Z. Naturforsch., C: Biosci.* **29C**, 545–551.
- Ogawa, T., and Vernon, L. P. (1969). *Biochim. Biophys. Acta* **180**, 334–346.
- Ogawa, T., Obata, F., and Shibata, K. (1966). *Biochim. Biophys. Acta* **112**, 223–234.
- Okamura, M. Y., Moskowitz, E., McElroy, J., Feher, G., and Steiner, L. (1973). *Biophys. Soc. Abstr.* **13**, 270a.
- Okamura, M. Y., Steiner, L. A., and Feher, G. (1974). *Biochemistry* **13**, 1394–1403.
- Okamura, M. Y., Isaacson, R. A., and Feher, G. (1975). *Proc. Natl. Acad. Sci. U.S.A.* **72**, 3491–3495.
- Okamura, M. Y., Ackerson, L. C., Isaacson, R. A., and Feher, G. (1976). *Biophys. Soc. Abstr.* **16**, 67.
- Okamura, M. Y., Isaacson, R. A., and Feher, G. (1978). *Biophys. J.* **21**, 8a.
- Okamura, M. Y., Isaacson, R. A., and Feher, G. (1979a). *Biochim. Biophys. Acta* **546**, 394–417.
- Okamura, M. Y., Fredkin, D., Isaacson, R. A., and Feher, G. (1979b). In "Tunneling in Biological Systems" (B. Chance, D. DeVault, H. Frauenfelder, R. A. Marcus, J. R. Schrieffer, and N. Sufin, eds.), pp. 729–744. Academic Press, New York.
- Okamura, M. Y., Isaacson, R. A., and Feher, G. (1980). *Fed. Proc., Fed. Am. Soc. Exp. Biol.* **39**, 1802.

- Okamura, M. Y., Debus, R. J., Kleinfeld, D., and Feher, G. (1982). In "Function of Quinones in Energy Conserving Systems" (B. Trumpower, ed.), pp. 299-317. Academic Press, New York.
- Olson, J. M. (1978). *Evol. Biol.* **11**, 1-37.
- Olson, J. M., and Thornber, J. P. (1979). In "Membrane Proteins in Energy Transduction" (R. A. Capaldi, ed.), pp. 279-340. Dekker, New York.
- Olson, J. M., Prince, R. C., and Brune, D. C. (1977). *Brookhaven Symp. Biol.* **28**, 238-246.
- Orlich, G., and Hauska, G. (1980). *Eur. J. Biochem.* **111**, 525-533.
- Overfield, R. E., Wraight, C. A., and DeVault, D. (1979). *FEBS Lett.* **105**, 137-142.
- Pachence, J. M., Dutton, P. L., and Blasie, J. K. (1979). *Biochim. Biophys. Acta* **548**, 348-373.
- Packham, N. K., Packham, C., Mueller, P., Tiede, D. M., and Dutton, P. L. (1980). *FEBS Lett.* **110**, 101-106.
- Parson, W. W. (1969). *Biochim. Biophys. Acta* **189**, 384-396.
- Parson, W. W. (1978). In "The Photosynthetic Bacteria" (R. K. Clayton and W. R. Sistrom, eds.), pp. 455-469. Plenum, New York.
- Parson, W. W., Clayton, R. K., and Cogdell, R. J. (1975). *Biochim. Biophys. Acta* **387**, 265-278.
- Philipson, K. D., Sato, V. L., and Sauer, K. (1972). *Biochemistry* **11**, 4591-4594.
- Pfister, K., Steinbeck, K. E., Gardener, G., and Arntzen, C. J. (1981). *Proc. Natl. Acad. Sci. U.S.A.* **78**, 981-985.
- Pierson, B. K., and Castenholz, R. W. (1978). In "The Photosynthetic Bacteria" (R. K. Clayton and W. R. Sistrom, eds.), pp. 179-198. Plenum, New York.
- Pierson, B. K., and Thornber, J. P. (1982). (in press).
- Prince, R., and Dutton, P. L. (1978a). In "The Photosynthetic Bacteria" (R. K. Clayton and W. R. Sistrom, eds.), pp. 439-453. Plenum, New York.
- Prince, R., and Dutton, P. L. (1978b). In "Light Transducing Membranes: Structure, Function and Evolution" (D. Deamer, ed.), pp. 167-186. Academic Press, New York.
- Prince, R. C., Baccarini-Melandri, A., Hauska, G. A., Melandri, B. A., and Crofts, A. R. (1975). *Biochim. Biophys. Acta* **387**, 212-227.
- Prince, R. C., Tiede, D. M., Thornber, J. P., and Dutton, P. L. (1977). *Biochim. Biophys. Acta* **462**, 467-490.
- Pucheu, N. L., Kerber, N. L., and Garcia, A. F. (1976). *Arch. Microbiol.* **109**: 301-305.
- Pulles, M. P. J., van Gorkom, H. J., and Willimssen, J. G. (1976). *Biochim. Biophys. Acta* **449**, 536-540.
- Reed, D. W., and Clayton, R. K. (1968). *Biochem. Biophys. Res. Commun.* **30**, 471-475.
- Reed, D. W., Raveed, D., and Reporter, M. (1975). *Biochim. Biophys. Acta* **387**, 368-378.
- Reiss-Husson, F., and Jolchine, G. (1972). *Biochim. Biophys. Acta* **256**, 440-451.
- Renger, G., Hagemann, R., Dohnt, G. (1981). *Biochim. Biophys. Acta* **636**, 17-26.
- Rivas, E., Reiss-Husson, F., and le Maire, M. (1980). *Biochemistry* **19**, 2943-2950.
- Romijn, J. C., and Ames, J. (1977). *Biochim. Biophys. Acta* **461**, 327-338.
- Rosen, D. (1979). Ph.D. Thesis, University of California, San Diego.
- Rosen, D., Okamura, M. Y., Feher, G., Steiner, L. A., and Walker, J. E. (1977). *Biophys. J.* **17**, 67 (abstr.).
- Rosen, D., Okamura, M. Y., and Feher, G. (1979). *Biophys. J.* **25**, 204a.
- Rosen, D., Feher, G., and Steiner, L. (1980a). *Fed. Proc., Fed. Am. Soc. Exp. Biol.* **39**, 1801.
- Rosen, D., Okamura, M. Y., and Feher, G. (1980b). *Biochemistry* **19**, 5687-5692.
- Rumberg, V. B. (1964). *Z. Naturforsch., B: Anorg. Chem., Org. Chem., Biochem., Biophys., Biol.* **19B**, 707-716.
- Rutherford, A. W., and Evans, M. C. W. (1980). *FEBS Lett.* **110**, 257-261.
- Sands, R. H., and Dunham, W. R. (1975). *Q. Rev. Biophys.* **7**, 443-504.
- Satoh, K. (1979). *Biochim. Biophys. Acta* **546**, 84-92.

- Satoh, K. (1981). *Proc. Int. Congr. Photosynth., 5th, (Abstr.) 1980* p. 501.
- Satoh, K., and Butler, W. L. (1978). *Plant Physiol.* **61**, 373-379.
- Sauer, K. (1975). In "Bioenergetics of Photosynthesis" (Govindjee, ed.), pp. 115-181. Academic Press, New York.
- Sauer, K. (1979). *Annu. Rev. Phys. Chem.* **30**, 155-178.
- Sauer, K., Dratz, E. A., and Coyne, L. (1968). *Proc. Natl. Acad. Sci. U.S.A.* **61**, 17-24.
- Sauer, K., Mathis, P., Acker, S., and van Best, J. A. (1978). *Biochim. Biophys. Acta* **503**, 120-134.
- Schönfeld, M., Montal, M., and Feher, G. (1979). *Proc. Natl. Acad. Sci. U.S.A.* **76**, 6351-6355.
- Shepherd, W. D., and Kaplan, S. J. (1978). *J. Bacteriol.* **135**, 656-667.
- Shiozawa, J. A., Alberte, R. S., and Thornber, J. P. (1974). *Arch. Biochem. Biophys.* **165**, 388-397.
- Shuvalov, V. A., and Asadov, A. A. (1979). *Biochim. Biophys. Acta* **545**, 296-308.
- Shuvalov, V. A., and Klimov, V. V. (1976). *Biochim. Biophys. Acta* **440**, 587-599.
- Shuvalov, V. A., and Parson, W. W. (1981). *Proc. Natl. Acad. Sci. U.S.A.* **78**, 957-961.
- Shuvalov, V. A., Dolan, E., and Ke, B. (1979). *Proc. Natl. Acad. Sci.* **76**, 770-773.
- Singer, S. J., and Nicolson, G. L. (1972). *Science* **175**, 720-731.
- Sistrom, W. R., Griffiths, M., and Stanier, R. Y. (1956). *J. Cell. Comp. Physiol.* **48**, 473-515.
- Skulachev, V. P. (1979). *Top. Photosynth.* **3**, 175-188.
- Slooten, L. (1972). *Biochim. Biophys. Acta* **275**, 208-218.
- Snozzi, M., and Bachofen, R. (1979). *Biochim. Biophys. Acta* **546**, 236-247.
- Sogo, P., Jost, M., and Calvin, M. (1959). *Radiat. Res., Suppl.* **1**, 511.
- Spector, M., and Winget, G. D. (1980). *Proc. Natl. Acad. Sci. U.S.A.* **77**, 957-959.
- Steck, T. L., and Fox, C. F. (1972). In "Membrane Molecular Biology" (C. F. Steck and A. D. Keith, eds.), pp. 27-75. Sinauer Assoc., Stamford, Connecticut.
- Steiner, L. A., Okamura, M. Y., Lopes, A. D., Moskowicz, E., and Feher, G. (1974a). *Biochemistry* **13**, 1403-1410.
- Steiner, L. A., Lopes, A. D., Okamura, M. Y., Ackerson, L. C., and Feher, G. (1974b). *Fed. Proc., Fed. Am. Soc. Exp. Biol.* **33**, 1461.
- Stern, E. A., Bunker, G., and Parson, W. (1979). In "Sixth Annual Stanford Synchrontron Radiation Lab Users' Group Meeting," SSRL Rep. No. 79/05, p. 90. Stanford University, Stanford, California.
- Stiehl, H. H., and Witt, H. T. (1969). *Z. Naturforsch., B: Anorg. Chem., Org. Chem., Biochem., Biophys., Biol.* **24B**, 1588-1598.
- Straley, S. C., Parson, W. W., Mauzerall, D. C., and Clayton, R. K. (1973). *Biochim. Biophys. Acta* **305**, 597-609.
- Sutton, M. R., Steiner, L. A., Abresch, E. C., and Feher, G. (1981). *Biophys. J.* **33**, 19a.
- Sutton, M. R., Steiner, L., Rosen, D., and Feher, G. (1982). *Biochemistry* (in press).
- Sybesma, C., and Vredenberg, W. J. (1963). *Biochim. Biophys. Acta* **75**, 439-441.
- Takamiya, A. (1971). In "Methods in Enzymology" (A. San Pietro, ed.), Vol. 23, pp. 603-613. Academic Press, New York.
- Thornber, J. P. (1969). *Biochim. Biophys. Acta* **172**, 230-241.
- Thornber, J. P. (1975). *Annu. Rev. Plant Phys.* **26**, 127-158.
- Thornber, J. P., Alberte, R. S., Hunter, F. A., Shiozawa, J. A., and Kan, K.-S. (1977). *Brookhaven Symp. Biol.* **28**, 132-148.
- Thurnauer, M. C., Katz, J. J., and Norris, J. R. (1975). *Proc. Natl. Acad. Sci. U.S.A.* **72**, 3270-3274.
- Tiede, D. M., Prince, R. C., Reed, G. H., and Dutton, P. L. (1976a). *FEBS Lett.* **65**, 301-304.
- Tiede, D. M., Prince, R. C., and Dutton, P. L. (1976b). *Biochim. Biophys. Acta* **449**, 447-467.

- Tiede, D. M., Prince, R. C., and Dutton, P. L. (1977). *Brookhaven Symp. Biol.* **28**, 213-237.
- Tiede, D. M., Leigh, J. S., and Dutton, P. L. (1978). *Biochim. Biophys. Acta* **503**, 524-544.
- Trebst, A. (1974). *Annu. Rev. Plant Physiol.* **25**, 423-458.
- Trosper, T. L., Benson, D. L., and Thornber, J. P. (1977). *Biochim. Biophys. Acta* **460**, 318-330.
- Vacek, K., Wong, D., and Govindjee (1977). *Photochem. Photobiol.* **26**, 269-276.
- Vadeboncoeur, C., Noel, H., Poirier, L., Cloutier, Y., and Gingras, G. (1979a). *Biochemistry* **18**, 4301-4308.
- Vadeboncoeur, C., Mamet-Bradley, M., and Gingras, G. (1979b). *Biochemistry* **18**, 4308-4314.
- Valkirs, G., and Feher, G. (1981). *Biophys. J.* **33**, 18a.
- Valkirs, G., and Feher, G. (1982). *J. Cell Biol.* (in press).
- Valkirs, G., Rosen, D., Tokayasu, K. T., and Feher, G. (1976). *Biophys. Soc. Abstr.* **16**, 223.
- van der Rest, M., and Gingras, G. (1974). *J. Biol. Chem.* **249**, 6446-6453.
- van Gorkom, H. J. (1974). *Biochim. Biophys. Acta* **347**, 439-442.
- van Grondelle, R., Romijn, J. C., and Holmes, N. G. (1976). *FEBS Lett.* **72**, 187-192.
- Velthuys, B. R., and Amesz, J. (1974). *Biochim. Biophys. Acta* **333**, 85-94.
- Vermaas, W. F. J., and Govindjee (1981). *Photochem. Photobiol.* **34**, 775-793.
- Vermeglio, A. (1977). *Biochim. Biophys. Acta* **459**, 516-524.
- Vermeglio, A., and Clayton, R. K. (1976). *Biochim. Biophys. Acta* **449**, 500-515.
- Vermeglio, A., and Clayton, R. K. (1977). *Biochim. Biophys. Acta* **461**, 159-165.
- Vernon, L. P., and Klein, S. M. (1975). *Ann. N.Y. Acad. Sci.* **244**, 281-296.
- Vernon, L. P., and Shaw, E. R. (1969). *Biochem. Biophys. Res. Commun.* **36**, 878-884.
- Vernon, L. P., and Shaw, E. R. (1971). In "Methods in Enzymology" (A. San Pietro, ed.), Vol. 23, pp. 277-288. Academic Press, New York.
- Vernon, L. P., Ke, B., Katoh, S., San Pietro, A., and Shaw, E. R. (1966). *Brookhaven Symp. Biol.* **19**, 102-114.
- Vernon, L. P., Shaw, E. R., Ogawa, T., and Raveed, D. (1971). *Photochem. Photobiol.* **14**, 343-357.
- Visser, J. W. M., Rijgersberg, C. P., and Gast, P. (1977). *Biochim. Biophys. Acta* **460**, 36-46.
- Warshel, A. (1980). *Proc. Natl. Acad. Sci. U.S.A.* **77**, 3105-3109.
- Wasielowski, M. R., Norris, J. R., Shipman, L. L., Lin, C. P., and Svec, W. A. (1981a). *Proc. Natl. Acad. Sci. U.S.A.* **78**, 2957-2961.
- Wasielowski, M. R., Norris, J. R., Crespi, H. L., and Harper, J. (1981b). *J. Am. Chem. Soc.* **103**, 7664-7666.
- Wessels, J. S. C. (1966). *Biochim. Biophys. Acta* **126**, 581-583.
- Wessels, J. S. C. (1968). *Biochim. Biophys. Acta* **153**, 497-500.
- Wessels, J. S. C., and Borchert, M. T. (1978). *Biochim. Biophys. Acta* **503**, 78-93.
- Wessels, J. S. C., van Alphen-van Waveren, O., and Voorn, G. (1973). *Biochim. Biophys. Acta* **292**, 741-752.
- Witt, H. T. (1975). In "Bioenergetics of Photosynthesis" (Govindjee, ed.), pp. 493-554. Academic Press, New York.
- Wright, C. A. (1977). *Biochim. Biophys. Acta* **459**, 525-531.
- Wright, C. A. (1978). *FEBS Lett.* **93**, 283-288.
- Wright, C. A. (1979). *Biochim. Biophys. Acta* **548**, 309-327.
- Wright, C. A., and Clayton, R. K. (1974). *Biochim. Biophys. Acta* **333**, 246-260.
- Yamamoto, H. L., and Vernon, L. P. (1969). *Biochemistry* **8**, 4131-4137.
- Zürner, H., Snozzi, M., Hanselmann, K., and Bachofen, R. (1977). *Biochim. Biophys. Acta* **460**, 273-279.

Part III

Primary Photochemistry

Electronic Structure and Function of Chlorophylls and Their Pheophytins*

LESTER L. SHIPMAN

I. Introduction.....	276
II. Chemical Structures.....	276
III. Self-Consistent Field Calculations.....	277
IV. Canonical Molecular Orbitals.....	278
V. Configuration Interaction Calculations.....	281
VI. Singlet States.....	282
VII. Triplet States.....	287
VIII. Cation Radical States.....	288
References.....	291

ABBREVIATIONS

Å	Angstrom
BChl <i>a</i>	Bacteriochlorophyll <i>a</i>
Bph <i>a</i>	Bacteriopheophytin <i>a</i>
Car	Carotenoid
Chl	Generic for chlorophyll
Chl <i>a</i>	Chlorophyll <i>a</i>
CI	Configuration interaction
D_n	The ($n+1$)th doublet state in order of increasing energy
ESR	Electron spin (paramagnetic) resonance
FSGO	Floating spherical Gaussian orbital
MO	Molecular orbital
Ph	Generic for pheophytin
Ph <i>a</i>	Pheophytin <i>a</i>
SCF	Self-consistent field
S_n	The ($n+1$)th singlet state in order of increasing energy
T_n	The n th triplet state in order of increasing energy

ABSTRACT

Ab initio molecular quantum mechanical calculations have proved quite useful for the characterization of the photosynthetically important electronic states of chlorophylls and pheophytins. These electronic states include the singlet, triplet, cation doublet, and anion

*The submitted manuscript has been authored by a contractor of the U.S. Government under Contract No. W-31-109-ENG-38.

doublet manifolds. The highest pair of occupied and the lowest pair of unoccupied molecular orbitals are especially important for the construction of the dominant configurations in the description of the low-lying states within each manifold. A very similar pattern of dominant electronic configurations emerged for all chlorophyll-like molecules studied including the green plant chlorophylls and their pheophytins and the bacterial chlorophylls and their pheophytins.

I. Introduction

The chlorophylls (Chls) of green plants and photosynthetic bacteria have several important functions in the primary photophysical and photochemical events of photosynthesis. First, the Chls are the primary light receptors in the photosynthetic membrane; singlet excitation initially deposited in other receptors [e.g., carotenoids (Car), linear tetrapyrroles] is passed to the Chls on a picosecond time scale. Second, a number of Chls act cooperatively as an antenna within the photosynthetic membrane to transfer singlet excitons to the reaction center and to transfer triplet excitons to carotenoids. Third, primary charge separation (i.e., electron transfer) takes place between Chls [photosystem I (PSI) of green plants] or between Chls and pheophytins (phs) (PSII of green plants and the PS of purple photosynthetic bacteria) in the reaction center. The oxidizing and reducing power generated by primary charge separation (see Parson and Ke, Chapter 8, this volume) is used to drive the chemical reactions of photosynthesis that would not otherwise proceed spontaneously.

Space limitations preclude a comprehensive review of Chl electronic structure and function. (For a discussion of the chemical structures, see Rebeiz and Lascelles, Chapter 15, this volume.) In this article we will focus on the results of recent *ab initio* quantum mechanical calculations of the singlet, triplet, and cation radical electronic manifolds of green plant chlorophyll *a* (Chl *a*) and bacterial bacteriochlorophyll *a* (BChl *a*), as well as their magnesium-free derivatives pheophytin *a* (Ph *a*), and bacteriopheophytin *a* (Bph *a*). Where possible, correlations between electronic structure and biological function will be drawn.

II. Chemical Structures

The chemical structures of Chl *a* and BChl *a* are shown in Fig. 1. The corresponding structures for Ph *a* and Bph *a*, respectively, are obtained by replacement of Mg by 2H. (Also see Rebeiz and Lascelles, Chapter 15,

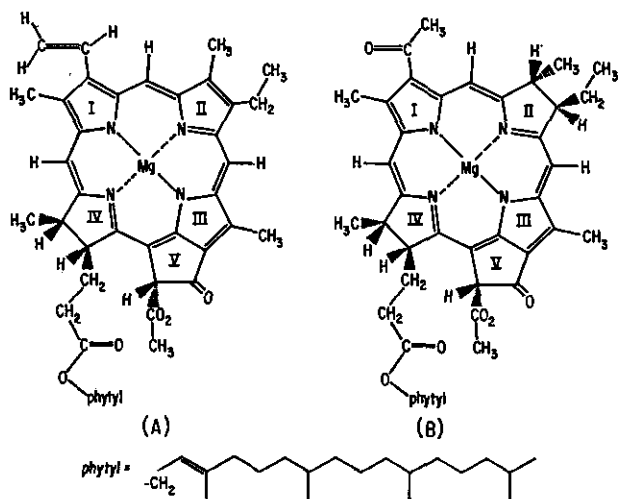

FIG. 1. Chemical structures for (A) Chl *a* and (B) BChl *a*. The corresponding structures for Ph *a* and Bph *a* are obtained by replacing Mg by 2H. The corresponding molecules ethyl chlorophyllide *a*, ethyl pheophorbide *a*, ethyl bacteriochlorophyllide *a*, and ethyl bacteriopheophorbide *a* are obtained by replacing phytyl by ethyl.

this volume.) All of the *ab initio* calculations discussed in this chapter were carried out on the smaller chlorophyllide and pheophorbide systems in which the phytyl group is replaced with an ethyl group. This substitution does not affect the electronic structure of the low-lying states because the phytyl chain is not in electronic conjugation with the macrocycle, and excited states involving a substantial amount of excitation on the phytyl chain are high-lying.

III. Self-Consistent Field Calculations

The *ab initio* calculations on Chls and Phs start with the construction of a molecular basis set by use of the molecular fragment procedure of Christoffersen and co-workers (Christoffersen, 1972; Christoffersen *et al.*, 1973). The basis set consists of two types of basis functions (χ_i): single floating spherical Gaussian orbitals (FSGOs) and subtractive combinations of two FSGOs placed 0.2 Bohr (0.106 Å) apart. The former is an *s*-type function and the latter is a *p*-type function. The ground state elec-

tronic wavefunction is taken to be a single Slater determinant composed of doubly-occupied canonical molecular orbitals (MOs). Each MO, ϕ_j , is a linear combination of FSGO basis functions as follows:

$$\phi_j = \sum_i C_{ij} \chi_i \quad (1)$$

The coefficients, C_{ij} , are varied according to the self-consistent field (SCF) procedure of Hall and Roothaan (Hall, 1951; Roothaan, 1951) until the total energy is minimized. The MOs for Chl *a*, Ph *a*, BChl *a*, and Bph *a* have been described (Spangler *et al.*, 1977a,b; Petke *et al.*, 1980b) and are reviewed in section IV.

IV. Canonical Molecular Orbitals

The canonical MOs for the four molecules under review were determined by use of the SCF procedure (Section III). The most important MOs for the description of low-lying excited states (Section VI) are the higher occupied and lower unoccupied MOs. Electron density contour maps for these MOs are shown in Figs. 2 and 3 for ethyl chlorophyllide *a* and ethyl bacteriochlorophyllide *a*, respectively. Essentially identical contour maps would have been obtained for Chl *a* and BChl *a*, respectively. The MO contour maps for Ph *a* and Bph *a* are also not shown for the same reason.

It should be noted that all of the MOs shown in Figs. 2 and 3 are delocalized π -type MOs. This has important significance for the electronic structure of Chls and Phs because it means that the first few electronic states in the singlet, triplet, cation doublet, and anion doublet manifolds are π -type.

A one-to-one comparison of the MO maps in Fig. 2 and 3 clearly shows that the MOs of Chl *a* and BChl *a* are strikingly similar. The largest difference comes from the reduction of a ring II double bond in Chl *a* to form the BChl *a* ring II. This reduction decreases the overall size of MOs 1 and 2* and, as predicted by a simple electron-in-a-ring quantum mechanical model, the orbital energies are displaced to higher energies (more positive) by this reduction (Fig. 4). A simple physical picture is that an electron confined to a smaller space will have a higher kinetic energy. According to Koopmans' theorem (Koopmans, 1934), the ionization potential can be approximated by the negative of the

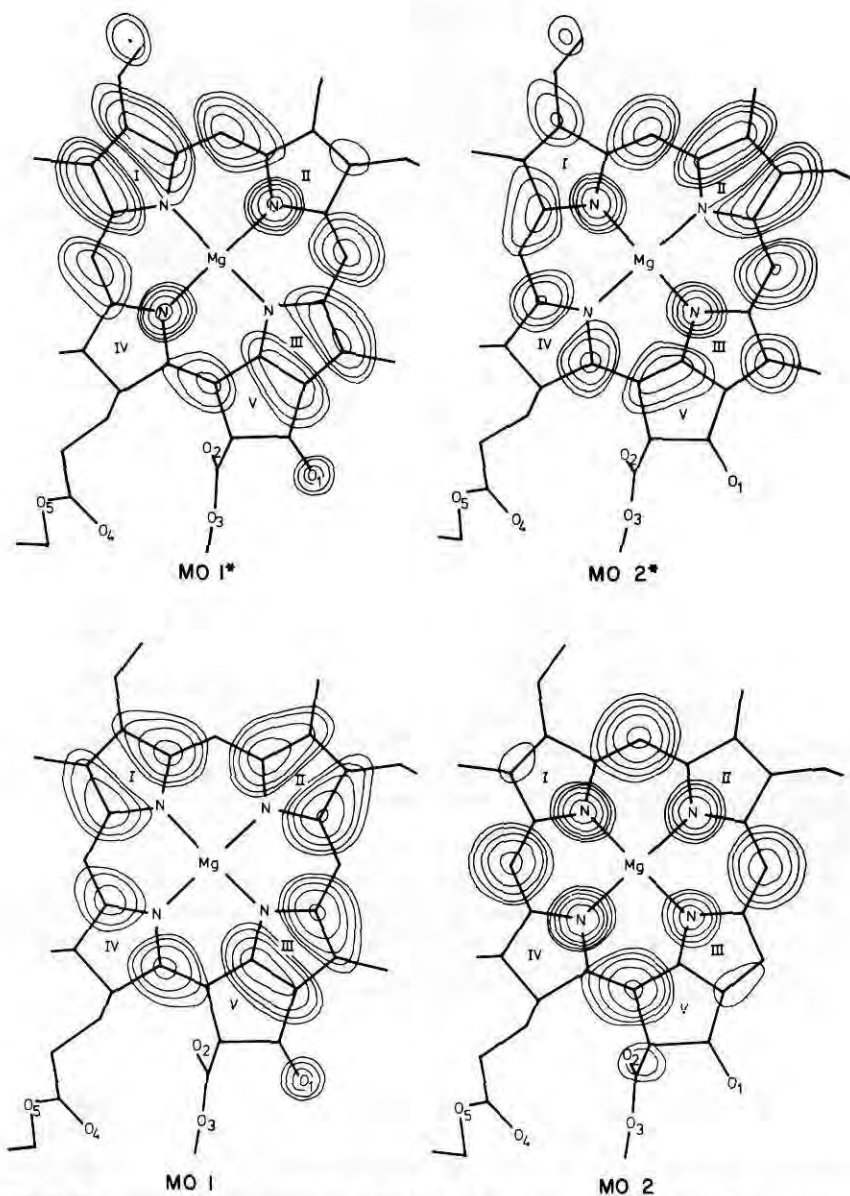

FIG. 2. Electron density contour maps for the highest pair of occupied molecular orbitals (MO 1 and MO 2) and the lowest pair of unoccupied molecular orbitals (MO 1* and MO 2*) in the ground state SCF wavefunction for ethyl chlorophyllide *a*. [Reproduced from Petke *et al.* (1979) with the permission of Pergamon Press Ltd.]

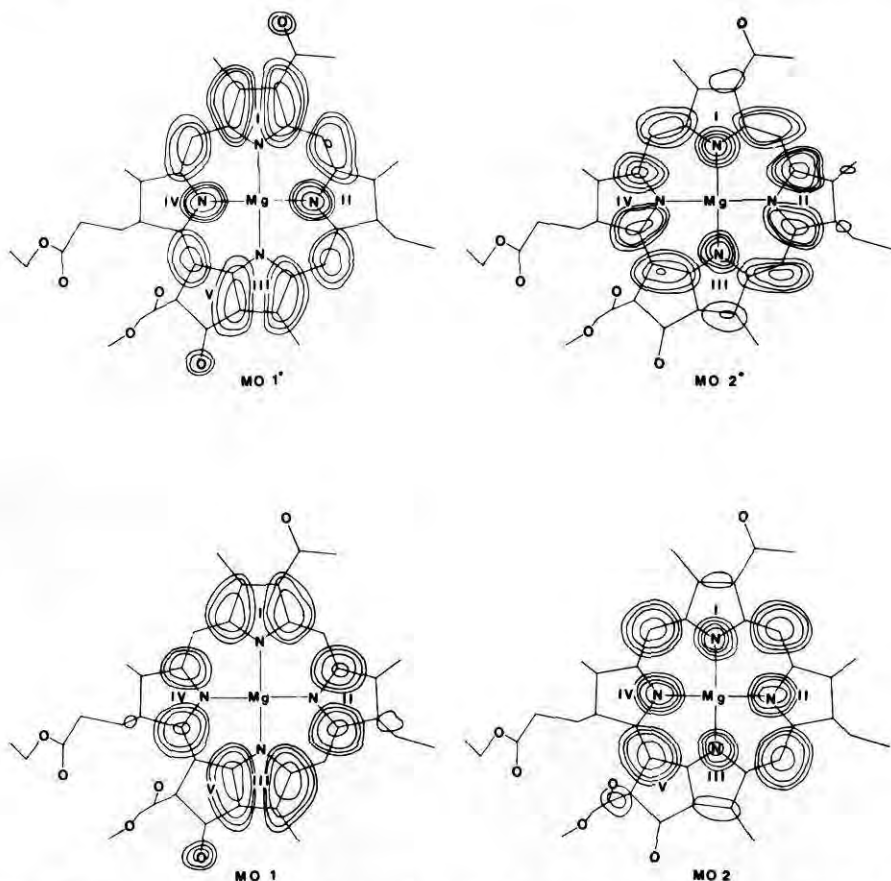

FIG. 3. Electron density contour maps for the highest pair of occupied molecular orbitals (MO 1 and MO 2) and the lowest pair of unoccupied molecular orbitals (MO 1* and MO 2*) in the ground state SCF wavefunction for ethyl bacteriochlorophyllide *a*. [Reproduced from Petke *et al.* (1980b) with the permission of Pergamon Press Ltd.]

orbital energy. In the one-electron oxidation of a Chl, an electron is removed from MO 1. Because the orbital energy of MO 1 is less negative for BChl *a* than for Chl *a*, it is substantially easier to oxidize BChl *a* than Chl *a*. This difference in oxidation potential between BChl and Chl is borne out by experiment where the $E_{1/2}$ oxidation potentials of Chl *a* and BChl *a* in CH_2Cl_2 are 0.52 V and 0.40 V versus SCE, respectively (Fajer *et al.*, 1974).

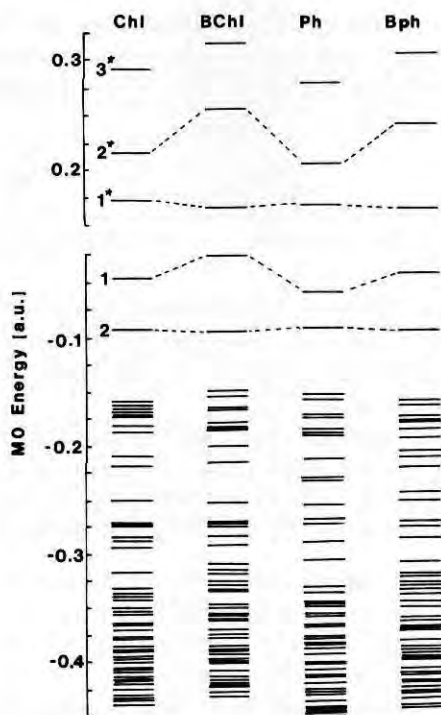

FIG. 4. Molecular orbital energies for ethyl chlorophyllide *a* (Chl), ethyl bacteriochlorophyllide *a* (BChl), ethyl pheophorbide *a* (Ph), and ethyl bacteriopheophorbide *a* (Bph). [Reproduced from Petke *et al.* (1980b) with the permission of Pergamon Press Ltd.]

V. Configuration Interaction Calculations

The configuration interaction (CI) wavefunction, ψ_k , for the k th electronic state of a given spatial symmetry and spin multiplicity is a linear combination of electronic configurations, ϕ_j ,

$$\Psi_k = \sum_j C_{jk} \Phi_j \quad (2)$$

where the set of configurations, $\{\phi_j\}$, is constructed from antisymmetrized products of molecular spin orbitals (Slater determinants). The generation of the set $\{\phi_j\}$ is a procedure that involves several steps. First, there is the selection of an initial set of parent configurations, $\{\phi_i^{(0)}\}$ which are expected to be major contributors to the states of in-

terest. Second, an initial set of configurations, $\{\phi_i^{(1)}\}$, is obtained by taking all possible single and double electronic excitations from the parent configurations, $\{\phi_i^{(0)}\}$. Third, the size of $\{\phi_i^{(1)}\}$ is reduced by discarding all members such that,

$$\left| \frac{\langle \Phi_i^{(1)} | \hat{\mathcal{H}} | \Phi_i^{(0)} \rangle^2}{\langle \Phi_i^{(1)} | \hat{\mathcal{H}} | \Phi_i^{(1)} \rangle - \langle \Phi_i^{(0)} | \hat{\mathcal{H}} | \Phi_i^{(0)} \rangle} \right| < \delta \quad (3)$$

where $\hat{\mathcal{H}}$ is the nonrelativistic Hamiltonian operator for the system and δ is a small threshold. Thus, second-order perturbation theory is used to discard those members of $\{\phi_i^{(1)}\}$ that do not interact appreciably with one or more members of $\{\phi_i^{(0)}\}$.

The set of parent configurations, $\{\phi_i^{(0)}\}$, plus the pared down set of configurations, $\{\phi_i^{(1)}\}$, are then used to obtain an expansion for the wavefunction ψ_k , Eq. (2). The coefficients, C_{jk} in Eq. (2), are the elements of the unitary matrix, \mathbf{C} , that diagonalizes the Hamiltonian matrix, \mathbf{H} , where

$$H_{ij} = \langle \phi_i | \hat{\mathcal{H}} | \phi_j \rangle \quad (4)$$

and

$$\mathbf{C}^\dagger \mathbf{H} \mathbf{C} = \epsilon \quad (5)$$

ϵ is the diagonal matrix that contains the energies of the states ψ_k .

If, after the first diagonalization of \mathbf{H} , one or more configurations from $\{\phi_i^{(1)}\}$ are found to be major contributors to a state of interest, then these $\phi_i^{(1)}$ are added to the set of parent configurations, and the preceding procedure is repeated. If, on the other hand, some of the parent configurations in the initially chosen set of parent configurations are found not to be major contributors to the states of interest, then they are deleted from the set of parent configurations and the preceding procedure is repeated. Thus, by use of the preceding outlined procedure, a set of configurations is assembled that satisfactorily describes the states of interest. A final diagonalization of Hamiltonian matrix, \mathbf{H} , using both $\{\phi_i^{(1)}\}$ and $\{\phi_i^{(0)}\}$ gives the CI expansion [Eq. (2)] for the states of interest.

VI. Singlet States

The singlet states of the Chls are very important in photosynthesis. The Chl ground state S_0 , is a singlet state and light excites Chls from S_0 to higher excited singlet states, S_n .



Also, *in vivo* fluorescence comes from the radiative decay of the S_1 state of the antenna Chls. (For reviews on Chl *a* fluorescence *in vivo*, see Govindjee *et al.* (1973), Papageorgiou (1975), Lavorel and Etienne (1977), and Govindjee and Jursinic, 1979.)



Singlet excitation in the form of singlet excitons (see Pearlstein, Chapter 7, this volume) moves rapidly through the antenna Chls to reach the reaction center Chls. It is this rapid diffusion of singlet excitons that allows many Chls to act cooperatively in light-harvesting. The physical mechanism for singlet excitation transfer involves coulombic coupling between the transition density, $\psi(S_0)\psi(S_1)$, on different Chls, where $\psi(S_0)$ and $\psi(S_1)$ are the electronic wavefunctions for the S_0 and S_1 electronic states, respectively. Finally, primary charge separation in the reaction center proceeds from a photoexcited singlet state of the reaction center Chls.

CI wavefunctions have been computed for the low-lying S_n states of ethyl chlorophyllide *a* and ethyl pheophorbide *a* (Petke *et al.*, 1979) as well as ethyl bacteriochlorophyllide *a* and ethyl bacteriopheophorbide *a* (Petke *et al.*, 1980b). The calculated singlet state energies as well as the triplet state energies (Section VII) of all four molecules are compared in Fig. 5. The energies reported in Fig. 5 are estimated transition energies,

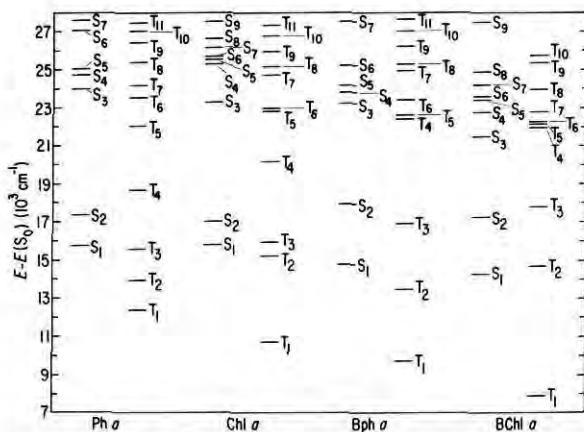

FIG. 5. Calculated $S_0 \rightarrow S_n$ and $S_0 \rightarrow T_n$ transition energies for the low-lying singlet and triplet states of ethyl pheophorbide (Ph) *a*, ethyl chlorophyllide (Chl) *a*, ethyl bacteriopheophorbide (Bph) *a*, and ethyl bacteriochlorophyllide (BChl) *a*. All transition energies are $\Delta E^{(est)}$ computed according to Eq. (8).

$\Delta E^{(est)}$; the calculated transition energies, $\Delta E^{(calc)}$ were linearly transformed according to the following equation:

$$\Delta E^{(est)} = 0.610 \Delta E^{(calc)} - 441 \text{ cm}^{-1} \quad (8)$$

Equation (8) substantially improves agreement between the calculated and measured spectra and was derived from earlier studies on simple porphyrins and chlorins (Petke *et al.*, 1978a,b). Comparisons between

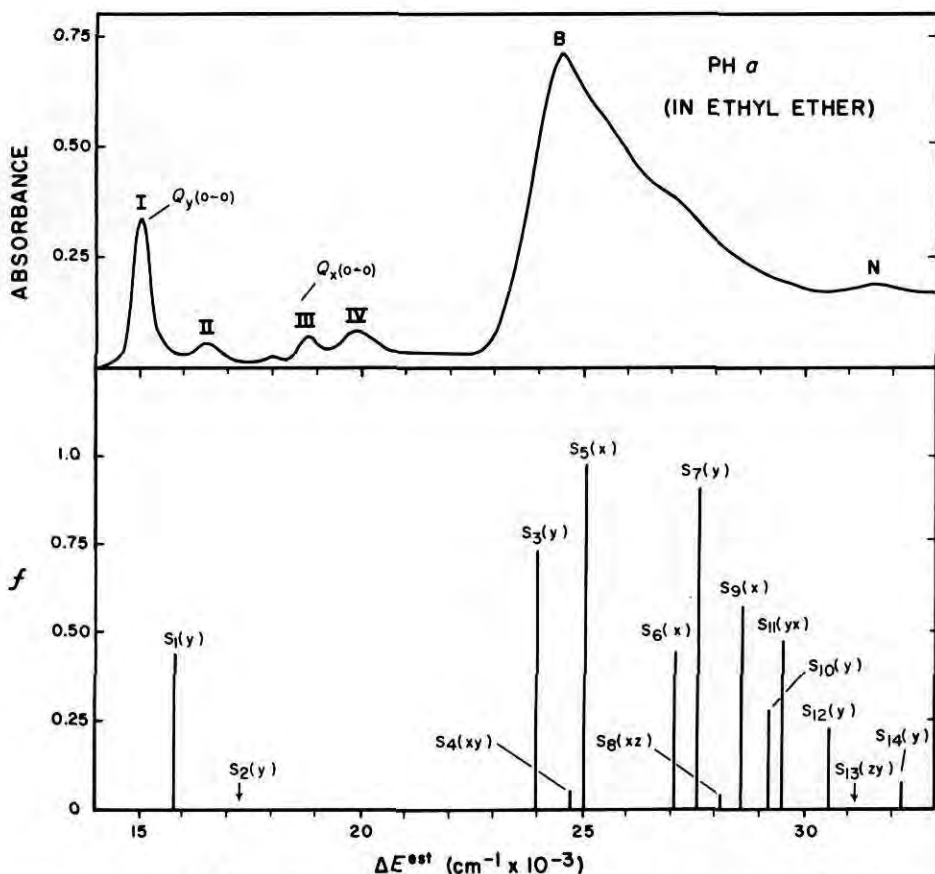

FIG. 6. Measured (upper) and calculated (lower) $S_0 \rightarrow S_n$ absorption spectra for Ph a (ethyl pheophorbide a or pheophytin a). Measured spectra for both are identical. The length of each line in the lower spectrum, calculated for ethyl pheophorbide a, is directly proportional to the oscillator strength of the corresponding transition. [Reproduced from Petke *et al.* (1979) with the permission of Pergamon Press Ltd.]

the computed and measured (Fajer *et al.*, 1974, 1976; Petke *et al.*, 1979) $S_0 \rightarrow S_n$ transition spectra for Ph *a*, Chl *a*, Bph *a*, and BChl *a* are given in Figs. 6, 7, 8, and 9, respectively. There is semiquantitative agreement between the computed and measured spectra. For all four molecules, there are two low-lying excited singlet states, S_1 and S_2 . After a gap between S_2 and S_3 , there is a closely spaced manifold of singlet states, S_3 , S_4 , and S_5 . When any of the higher excited singlet states, S_n ($n > 1$), are populated by light absorption, there is a rapid relaxation to S_1 . Thus,

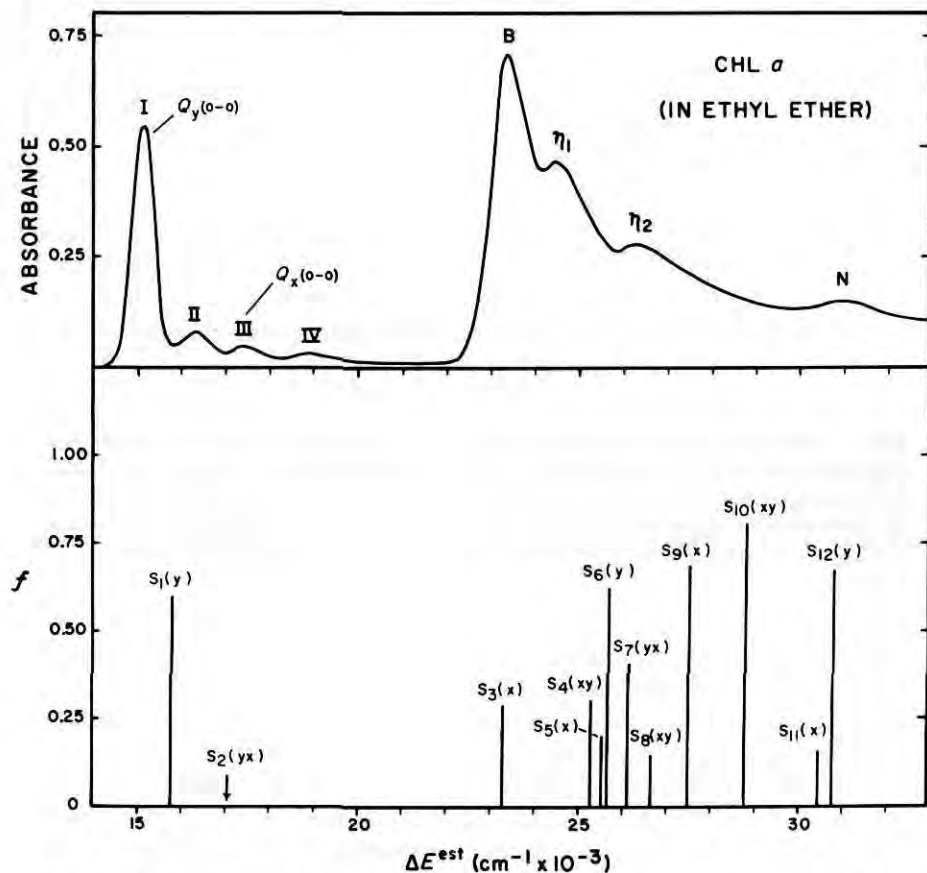

FIG. 7. Measured (upper) and calculated (lower) $S_0 \rightarrow S_n$ absorption spectra for Chl *a* (ethyl chlorophyllide *a* or chlorophyll *a*). Measured spectra for both are identical. The length of each line in the lower spectrum, calculated for ethyl chlorophyllide *a*, is directly proportional to the oscillator strength of the corresponding transition. [Reproduced from Petke *et al.* (1979) with the permission of Pergamon Press Ltd.]

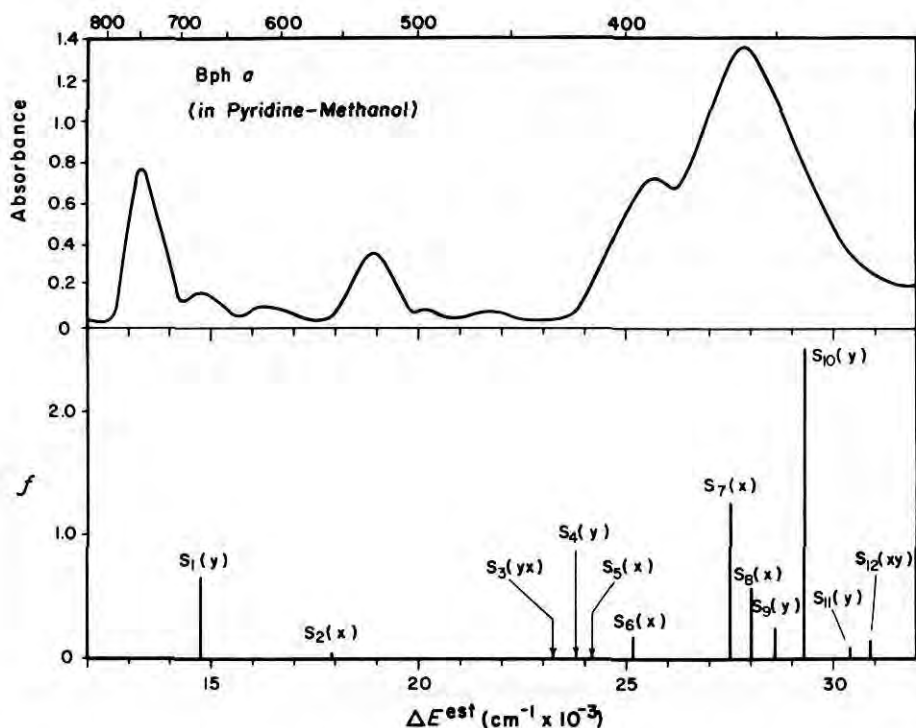

FIG. 8. Measured (upper; Fajer *et al.*, 1976) and calculated (lower) $S_0 \rightarrow S_n$ absorption spectra for Bph *a* (ethyl pheophorbide *a* or bacteriopheophytin *a*). Measured spectra for both are identical. The length of each line in the lower spectrum, calculated for bacteriopheophorbide *a*, is directly proportional to the oscillator strength of the corresponding transition. [Reproduced from Petke *et al.* (1980b) with the permission of Pergamon Press, Ltd.]

although the S_n ($n > 1$) states are important for light absorption, they are relatively unimportant for both singlet energy transfer among antenna molecules and for primary charge separation in the reaction center. Only the S_1 state is important for these latter processes.

The dominant configuration composition of the S_0 , S_1 , and S_2 states is the same for all four molecules. S_0 is dominated by the ground SCF configuration (Section III). S_1 is dominated by two configurations, which correspond to a $1 \rightarrow 1^*$ and $2 \rightarrow 2^*$ (See Figs. 2 and 3) one-electron excitations from the ground-state configuration. The S_2 state is dominated by two configurations, which correspond to $1 \rightarrow 2^*$ and $2 \rightarrow 1^*$ one-electron excitations from the ground state configuration.

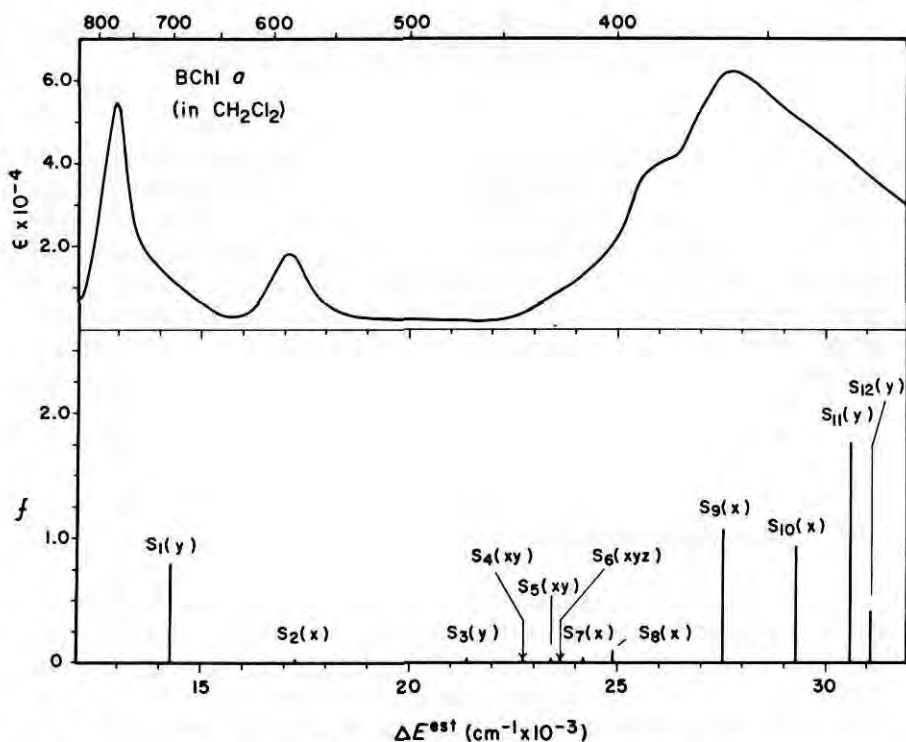
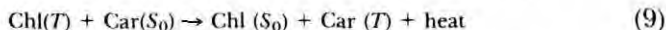

FIG. 9. Measured (upper; Fajer *et al.*, 1974) and calculated (lower) $S_0 \rightarrow S_n$ absorption spectra for BChl *a* (ethyl bacteriochlorophyllide *a* or bacteriochlorophyll *a*). Measured spectra for both are identical. The length of each line in the lower spectrum, calculated for bacteriochlorophyll *a*, is directly proportional to the oscillator strength of the corresponding transition. [Reproduced from Petke *et al.* (1980b) with the permission of Pergamon Press Ltd.]

VII. Triplet States

There is no conclusive evidence for the participation of Chl triplet states on the primary pathway leading to *in vivo* charge separation. In particular, Chl antennas use singlet excitons to carry electronic excitation to the reaction centers, and reaction center photochemistry is initiated from an excited singlet state. (Also see Pearlstein Chapter 7, and Parson & Ke Chapter 8, this volume.) Triplet states are formed in secondary processes, however, from the decay of singlet states in antennas and from charge recombination in the reaction centers when the normal forward electron transfer is blocked. When Chl triplet states are formed

by either of these processes at physiological temperatures, triplet excitation is transferred from Chls to carotenoids (Car) as follows.



The computed triplet energy levels for ethyl pheophorbide *a*, ethyl chlorophyllide *a*, ethyl bacteriopheophorbide *a*, and ethyl bacteriochlorophyllide *a* are given in Fig. 5. For all four molecules, the lowest triplet state (T_1) lies substantially below S_1 , and the T_1 energies decrease in the order Ph *a*, Chl *a*, Bph *a*, BChl *a*. For both Ph *a* and Chl *a*, the T_3 state is nearly degenerate with S_1 ; on the basis of favorable Franck–Condon factors intersystem crossing should proceed from S_1 to T_3 . For Bph *a* and BChl *a*, it is T_2 and not T_3 that is closest to S_1 . For all four molecules, the dominant configurational composition of T_1 is a $1 \rightarrow 1^*$ (See Figs. 2 and 3) one-electron transition from the ground state configuration.

VIII. Cation Radical States

Because Chls are the primary electron donors in the reaction centers, primary charge separation generates Chl cation radicals. Chl a^+ and BChl a^+ are generated in green plants and photosynthetic bacteria, respectively. These radicals have characteristic ESR signals that are narrower than the corresponding signals for monomeric Chl or BChl *in vitro* (see Okamura *et al.*, Chapter 5, and Parson and Ke, Chapter 8, this volume). This narrowing has been attributed to the delocalization of the unpaired electron over more than one BChl, probably two (Norris *et al.*, 1971). This delocalization over two BChls was confirmed by electron-nuclear double resonance spectroscopy (Norris *et al.*, 1974).

The low-lying cation doublet and cation quartet states of ethyl chlorophyllide *a* and ethyl bacteriochlorophyllide *a* have been computed (Petke *et al.*, 1980a). Their energy levels are shown in Figs. 10 and 11, respectively, along with experimental absorption spectra (Fajer *et al.*, 1974; Davis *et al.*, 1979). The density of states in the cation doublet manifold is clearly greater than the density of states in either the singlet or triplet manifolds (compare Figs. 10 and 11 with Figs. 5, 6, and 7). However, most of the transitions from the lowest cation doublet state (D_0) to the excited doublet states (D_n) do not carry appreciable oscillator strength. For Chl a^+ and BChl a^+ molecules, there are infrared transitions that are weak, but observable; these correspond to $D_0 \rightarrow D_5$ for the case of Chl $^+$ and $D_0 \rightarrow D_3$ and $D_0 \rightarrow D_5$ for the BChl a^+ case. Similar, but red shifted, transitions have been observed in oxidized reaction centers *in vivo*.

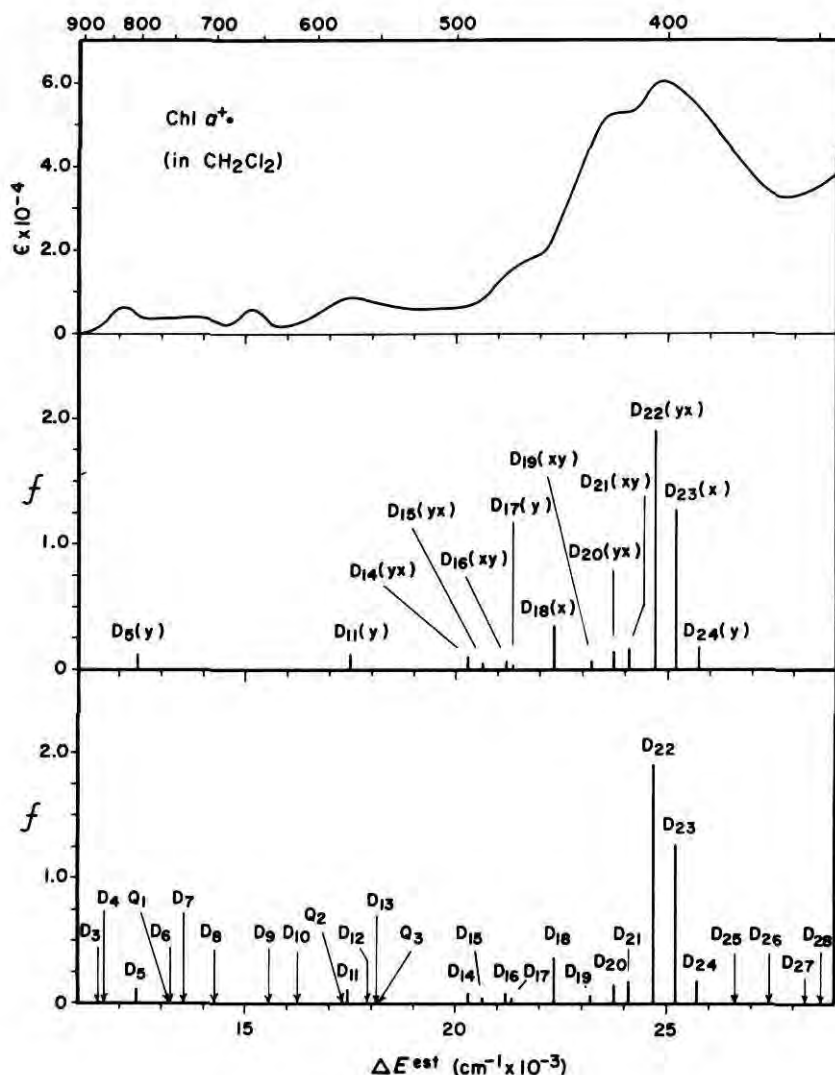

FIG. 10. Measured (upper; Davis *et al.* 1979) and calculated (middle and lower) $D_0 \rightarrow D_n$ absorption spectra for Chl a^+ (ethyl chlorophyllide a^+ or chlorophyll a^+). Measured spectra for both are identical. The length of each line in the middle and lower spectra, calculated for ethyl chlorophyllide a^+ , is directly proportional to the oscillator strength of the corresponding transition. The symbols Q_n correspond to the cation quartet states. [Reproduced from Petke *et al.* (1980a) with the permission of Pergamon Press Ltd.]

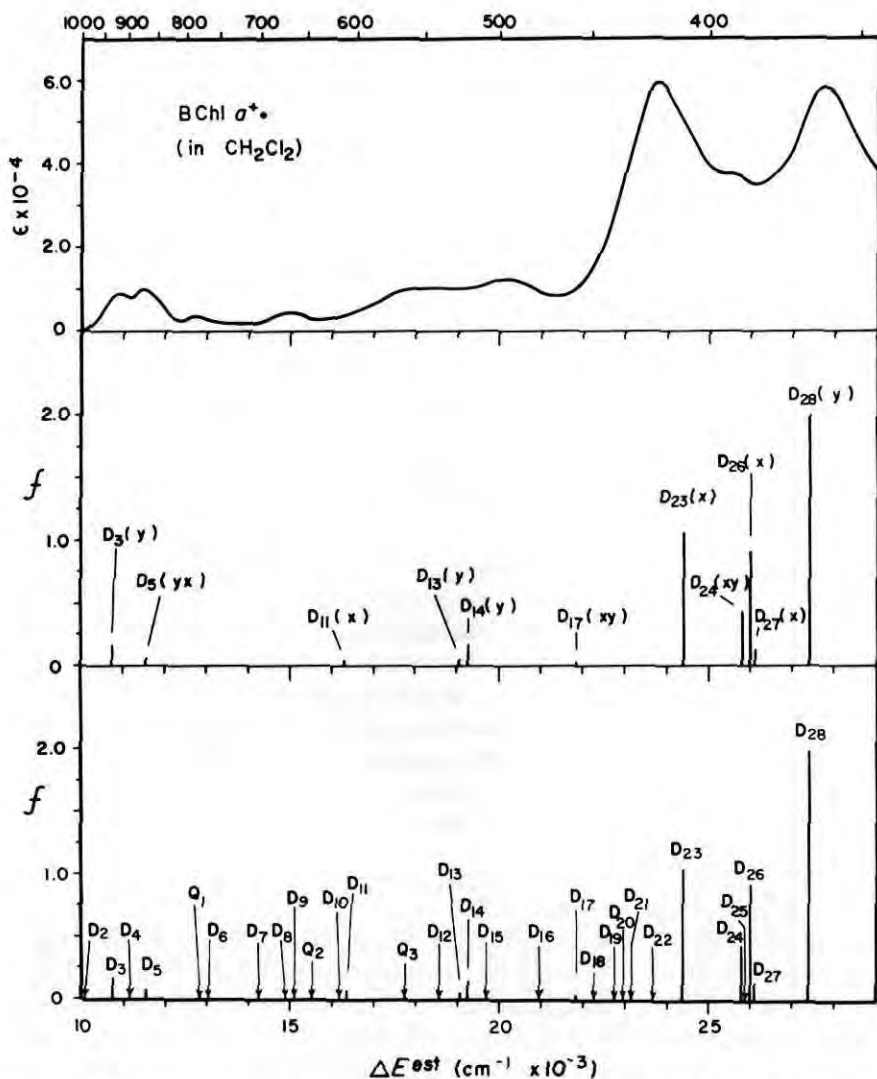

FIG. 11. Measured (upper; Fajer *et al.*, 1974) and calculated (middle and lower) absorption spectra for Chl a^+ (ethyl bacteriochlorophyllide a^+ or bacteriochlorophyll a^+). Measured spectra for both are identical. The length of each line in the middle and lower spectra, calculated for ethyl chlorophyllide a^+ , is directly proportional to the oscillator strength of the corresponding transition. The symbols Q_n correspond to the cation quartet states. [Reproduced from Petke *et al.* (1980a) with the permission of Pergamon Press Ltd.]

Acknowledgments

The *ab initio* SCF and CI calculations were carried out in collaboration with J. D. Petke, G. M. Maggiora, R. E. Christoffersen, and D. Spangler. I wish to acknowledge with appreciation their considerable contributions to these theoretical studies. I also gratefully acknowledge support of these studies by the Division of Chemical Sciences, Office of Basic Energy Sciences, United States Department of Energy.

REFERENCES

- Christoffersen, R. E. (1972). *Adv. Quantum Chem.* **6**, 333–393.
- Christoffersen, R. E., Spangler, D., Hall, G. G., and Maggiora, G. M. (1973). *J. Am. Chem. Soc.* **95**, 8526–8536.
- Davis, M. S., Forman, A., and Fajer, J. (1979). *Proc. Natl. Acad. Sci. U.S.A.* **76**, 4170–4178.
- Fajer, J., Borg, D. C., Forman, A., Felton, R. H., Dolphin, D., and Vegh, L. (1974). *Proc. Natl. Acad. Sci. U.S.A.* **71**, 994–998.
- Fajer, J., Davis, M. S., Brune, D. C., Spaulding, L. D., Borg, D. C., and Forman, A. (1976). *Brookhaven Symp. Biol.* **28**, 316–337.
- Govindjee, and Jursinic, P. (1979). *Photochem. Photobiol. Rev.* **4**, 125–205.
- Govindjee, Papageorgiou, G., and Rabinowitch, E. (1973). In "Practical Fluorescence: Theory, Methods, and Techniques" (G. G. Guilbault, ed.), pp. 543–575. Dekker, New York.
- Hall, G. G. (1951). *Proc. R. Soc. London Ser. A* **205**, 541–552.
- Koopmans, T. A. (1934). *Physica (Amsterdam)* **1**, 104–113.
- Lavorel, J., and Etienne, A.-L. (1977). In "Primary Processes of Photosynthesis" (J. Barber, ed.), pp. 203–268. Elsevier/North-Holland, Amsterdam.
- Norris, J. R., Uphaus, R. A., Crespi, H. L., and Katz, J. J. (1971). *Proc. Natl. Acad. Sci. U.S.A.* **68**, 625–628.
- Norris, J. R., Scheer, H., Druyan, M. E., and Katz, J. J. (1974). *Proc. Natl. Acad. Sci. U.S.A.* **71**, 4897–4900.
- Papageorgiou, G. (1975). In "Bioenergetics of Photosynthesis" (Govindjee, ed.), pp. 319–371. Academic Press, New York.
- Petke, J. D., Maggiora, G. M., Shipman, L. L., and Christoffersen, R. E. (1978a). *J. Mol. Spectrosc.* **71**, 64–84.
- Petke, J. D., Maggiora, G. M., Shipman, L. L., and Christoffersen, R. E. (1978b). *J. Mol. Spectrosc.* **73**, 311–331.
- Petke, J. D., Maggiora, G. M., Shipman, L. L., and Christoffersen, R. E. (1979). *Photochem. Photobiol.* **30**, 203–223.
- Petke, J. D., Maggiora, G. M., Shipman, L. L., and Christoffersen, R. E. (1980a). *Photochem. Photobiol.* **31**, 243–257.
- Petke, J. D., Maggiora, G. M., Shipman, L. L., and Christoffersen, R. E. (1980b). *Photochem. Photobiol.* **32**, 399–414.
- Roothaan, C. C. J. (1951). *Rev. Mod. Phys.* **23**, 69–89.
- Spangler, D., Maggiora, G. M., Shipman, L. L., and Christoffersen, R. E. (1977a). *J. Am. Chem. Soc.* **99**, 7470–7477.
- Spangler, D., Maggiora, G. M., Shipman, L. L., and Christoffersen, R. E. (1977b). *J. Am. Chem. Soc.* **99**, 7478–7489.

Chlorophyll Singlet Excitons

ROBERT M. PEARLSTEIN

I. Introduction.....	294
A. Exciton Concept.....	294
B. Importance of Singlet Excitons.....	295
II. Exciton Effects in Steady State Optical Spectra.....	295
A. Description of Effects.....	296
B. Standard Theory.....	297
C. Bandwidths and Degenerate-Ground-State Theory.....	300
D. Difficulty of Experimentally Testing Exciton Theory in Chlorophyll Systems.....	301
III. Exciton States of Antenna Chlorophyll-Proteins.....	302
A. <i>Prosthecochloris</i> Bacteriochlorophyll <i>a</i> -Protein.....	302
B. Light-Harvesting-R-26 Protein.....	307
C. Chlorophyll <i>a/b</i> Protein.....	308
IV. Exciton Migration from Antenna to Reaction Center.....	309
A. Coupling Energy, J , and the Nature of the Motion.....	310
B. Hopping Exciton Theory.....	311
C. Experimental Tests of Theory.....	320
V. Exciton Effects in Picosecond Optical Spectra.....	323
VI. Exciton Effects within Reaction Center Complexes.....	323
References.....	327

ABBREVIATIONS

BChl	Bacteriochlorophyll
Bph	Bacteriopheophytin
CD	Circular dichroism
Chl	Chlorophyll
DGS	Degenerate-ground-state
ENDOR	Electron-nuclear double resonance
ESR	Electron spin (paramagnetic) resonance
LD	Linear dichroism
LHCP	Light-harvesting chlorophyll <i>a/b</i> -protein complex, is equivalent to Chl <i>a/b</i> -protein in this chapter
PSII	Photosystem II
RC	Reaction center
<i>Rp.</i>	<i>Rhodospseudomonas</i>

ABSTRACT

Chlorophyll (Chl) singlet excitons, biologically important as the carriers of excitation energy from antenna to reaction center (RC) Chl in photosynthetic organisms, also produce spectroscopic effects that can aid in the analysis of Chl-protein structure. The exciton interaction energy of Chls or bacteriochlorophylls (BChls) in antenna protein complexes seems not to exceed $\sim 100 \text{ cm}^{-1}$. Exciton analysis of RC optical spectra calls into question the existence of special-pair BChl, which would require a much larger interaction energy ($\sim 400 \text{ cm}^{-1}$).

New developments in exciton theory lead to a unified concept of the exciton, in contrast to older ideas that included an artificial distinction between "exciton" and "excitation transfer" among identical molecules. In spite of this, the well-established theory of exciton hopping on regular lattices of pigment molecules seems still to account for observed fluorescence decay of photosynthetic Chl arrays, including data from carefully extrapolated picosecond spectroscopy. As techniques become more advanced, picosecond and subpicosecond spectroscopies hold the promise of additional challenges to the exciton theorist.

Many exciton-related topics have been treated cursorily, or not at all. Among the former are collisions of excitons and fluorescence depolarization by exciton migration. The latter includes the control of excitation transfer between photosystems, which now has its own considerable literature (see, e.g., Butler, 1979; Wong *et al.*, 1981).

I. Introduction

Excited-state energy transfer among photosynthetic pigments is well known and has a long history (Franck and Teller, 1938; Duysens, 1952, 1964; Bay and Pearlstein, 1963; Knox, 1975, 1977). Two categories of transfer may be distinguished—heterotransfer and homotransfer. The former, signaled by sensitized fluorescence, occurs between chemically dissimilar pigments, e.g. from Chl *b* to Chl *a*. The latter occurs within groups of chemically identical pigments and is the subject of this chapter.

A. Exciton Concept

In molecular biophysics, an electronic excited state whose energy resides on more than one of a group of identical molecules during the lifetime of the state is called an *exciton* (Sybesma, 1977). The term derives from solid state physics (Knox, 1963; Dexter and Knox, 1965; Davydov, 1971), where it is given a more precise meaning as a quantum of both definite energy and momentum. Here, as is the practice in the photosynthesis literature, it will be used in the looser sense.

The motion of an exciton from one molecule to another may be

described, depending on circumstances, as abrupt (hopping) or as continuous (oscillating or coherent). It is important to realize that *both* types of motion arise from the *same* physical mechanism (see Section IV,A).

B. Importance of Singlet Excitons

Excitons are designated singlet or triplet dependent on whether the electronic excited state involved is a singlet or a triplet (see Shipman, Chapter 6, this volume). Chlorophyll triplet states occur in photosynthetic systems (Levanon and Norris, 1978; Frank *et al.*, 1979; Wraight, Chapter 2, Parson and Ke, Chapter 8, this volume) but are interesting mainly as a diagnostic tool (Monger and Parson, 1977), and are not considered here. Singlet excitons are of great importance in photosynthesis because they carry the absorbed light energy from the photochemically inert antenna pigments to the photochemically active RCs (see, for example, Govindjee and Govindjee, 1975; Knox, 1975, 1977; Sauer, 1975, 1978).

Among the singlet states of Chl or BChl, the lowest excited, or S_1 , state is the most important for energy transfer. This is because the S_n states ($n > 1$) lose energy and decay into the S_1 in a time, usually < 1 psec, that is short compared to the duration of a typical multistep transfer process. Even when the effects of excitons at short times are studied, the S_1 excitons are still the most interesting because, with one exception, the higher singlet states are poorly resolved spectroscopically. The exception is the S_2 state of BChl (*a* or *b*), but effects of BChl S_2 excitons are often too small to observe because their transition dipole moments are smaller by a factor of ~ 10 (see Section II,B and Shipman, Chapter 6, this volume). Unless noted otherwise, in what follows "exciton" implies " S_1 exciton."

This chapter is mainly a brief survey, with excursions of slightly greater depth into four topics: standard theory of the exciton dimer; exciton states of BChl-protein antenna complexes; Förster theory of exciton migration and trapping (by the RC) in lattice models of photosynthetic antenna arrays; and an exciton theoretical analysis of primary donor BChl in purple bacterial RCs.

II. Exciton Effects in Steady State Optical Spectra

In ordinary absorption spectroscopy, even though the exciting light is steady, one usually thinks of the molecular electronic transitions induced

by that light as occurring within about one period of the electromagnetic field at the optical frequency, i.e., an electron "jumps" from an orbital of the S_0 state to one of a higher singlet in a time, $\lambda/c = 10^{-15}$ sec or 1 fsec (λ = wavelength, c = speed of light). Although not quantum mechanically elegant, this description suffices for most purposes, including present ones. From this point of view, "absorption-type" optical spectra—which here include absorption, circular dichroism (CD), and linear dichroism (LD) spectra—can provide information about exciton effects coincident with the creation of the exciton. Those effects, which can be useful in analyzing structural models of Chl-protein complexes, are considered in this section. Exciton effects in fluorescence, which reflects the S_1 state at a later time, are mentioned in Section IV.

A. Description of Effects

Excitons manifest themselves in absorption spectra as shifts or splittings of peaks. These are observed by comparing the spectrum of, say, a Chl-protein complex with that of the chemically equivalent Chl in an organic solvent (Sauer, 1975). The longest wavelength absorption peak (corresponding to the $S_0 \rightarrow S_1$ transition) of the former is typically red-shifted compared to that of the latter. The former's peak may also show splitting or narrowing compared to the latter's, especially at cryogenic temperatures, where peaks are frequently narrower and therefore better resolved. It must be emphasized that spectral shifts can have nonexcitonic, as well as excitonic, origins (see Sections III and VI), and should be interpreted cautiously.

Circular dichroism is the difference in absorption between left-hand and right-hand circularly polarized light (Tinoco and Cantor, 1970). It arises from certain asymmetries of structure (chiralities) that can be either intra- or intermolecular. Circular dichroism induced by exciton interactions falls in the latter category. The signature of excitonic CD is a conservative band of large magnitude. Here, "conservative" means that, for a spectral region corresponding to a single electronic transition, the area under the positive portion of the band, plotted on an energy scale, equals that under the negative. In magnitude, the peak CD, per unit absorption, is typically 10^{-3} for the red bands of Chl-proteins, a factor of 10 or 20 larger than that of the nonexcitonic (and nonconservative) CD observed for monomeric Chl or BChl in a solvent (Sauer, 1978). For the special case of an exciton-coupled dimer, conservation requires symmetric positive and negative lobes of *equal width*.

Linear dichroism is the difference in absorption between light that is linearly (or plane) polarized parallel and perpendicular to a macroscopic

symmetry axis of the sample. Customarily, the axis is induced in the sample by the experimenter, e.g., by stretching a film or compressing a gel in which a Chl-protein complex has been embedded. The spectral features characteristic of excitons are qualitatively similar to those in absorption (but can be of either sign), but generally they are more numerous and also provide complementary information. Photoselection is a related technique, applicable to reduced RCs, in which the axis is defined by the polarization of a second, actinic, light source (see Breton and Vermeglio, Chapter 4, this volume).

B. Standard Theory

The theory of molecular exciton interactions described by Kasha (1963; see also Kasha *et al.*, 1965) and by Tinoco (1963), here called the *standard theory*, is also sometimes termed *matrix theory* or *strong-coupling theory*. (The last term can be misleading and should be avoided.) The standard theory ignores vibronic effects, which makes it simple but limits its usefulness. Each of the identical, interacting molecules (e.g., BChl *a*) is represented theoretically as a spatial distribution of oscillating electric charge, which corresponds to a weighted product of the excited and ground state electronic orbitals. For simplicity, the distribution is frequently taken to be a point dipole, but that is not essential in the standard theory and more complex distributions [e.g., extended dipoles (Chang, 1977); distributed point monopoles (Weiss, 1972)] have been used. The exciton interaction, which is symmetric for each pair of molecules, is the resonance induced in each oscillating dipole by the proximity of the others. Quantum mechanically, this gives rise to both the spectroscopic effects and to intermolecular energy transfer.

1. EXCITON DIMER

It is simplest to consider first the case of two interacting Chls or BChls. The theory of the exciton dimer (not necessarily a structural dimer) is immediately applicable to the light-harvesting (LH-R-26) antenna complex of *Rp. sphaeroides* (Section III,B) and to special-pair models of primary donor Chl or BChl (Section VI).

If the two interacting Chls are in identical environments, the S_1 state is split by a resonance interaction, of energy J , into two states, of energies $+J$ and $-J$ relative to the original S_1 state energy (sometimes called the *band-center energy*). These are termed the (+) and the (-) exciton states, respectively, denoting the relative signs of the individual molecules' wave functions in the composite exciton wave function. Note that if J is

positive, the (+) state is higher in energy than the (-) state, but the reverse is true if J is negative. For point dipoles

$$J = (5.04 \mu^2/R^3) (\cos \alpha - 3 \cos \beta_1 \cos \beta_2) \quad (1)$$

where J is in cm^{-1} , dipole strength μ^2 is in D^2 ($D = \text{Debye} = 10^{-18} \text{esu}\cdot\text{cm}$), dipole separation R is in nm, α is the angle between the two dipoles, and the β 's are the angles between each dipole and the line joining them.

Each exciton state gives rise to an absorption band of strength (for point dipoles),

$$A_{\pm} = \mu^2 (1 \pm \cos \alpha) \quad (2)$$

whose ratio is,

$$A_+/A_- = \cot^2(\alpha/2) \quad (3)$$

If α is near 90° , the ratio is near unity, but from Eq. (1), J is then small. Thus, when the bands are nearly equal in strength, the separation is usually too small to observe in absorption except as a slight broadening. For dipoles parallel and in line ($\alpha = \beta_1 = \beta_2 = 0$), $J = -10.08 \mu^2/R^3$ (the largest possible absolute value), and from Eq. (2), $A_- = 0$. In this case, all the strength is in the (+) state, which is *lower* in energy ($J < 0$), i.e. corresponds to the *longer* wavelength transition, so that one observes an excitonic red shift whose magnitude in cm^{-1} is $10.08 \mu^2/R^3$. Similarly, for parallel dipoles each perpendicular to the line joining them ($\alpha = 0$; $\beta_1 = \beta_2 = 90^\circ$), $J = +5.04 \mu^2/R^3$, and again all the strength is in the (+) state, but now that state is *higher* in energy ($J > 0$), and the absorption band undergoes an excitonic blue shift of $5.04 \mu^2/R^3$. Intermediate situations are, of course, possible.

The excitonic CD has rotational strength, in Debye-Bohr magnetons, of

$$C_{\pm} = \pm 1.7 \times 10^{-5} \mu^2 \nu_0 R \sin \alpha \cos \gamma \quad (4)$$

where ν_0 is the band-center energy (above the ground state) in cm^{-1} , and γ is the angle between the line joining the dipoles and the normal to the plane defined by the vector cross product of the two dipole moments. Of course, $C_+ + C_- = 0$, i.e., the CD is conservative. If the two dipoles are parallel ($\alpha = 0$), or otherwise coplanar ($\alpha = 90^\circ$), the excitonic CD vanishes. Thus, it vanishes if, for example, the absorption of the exciton dimer is maximally red- or blue-shifted. In general, there is a CD peak of one sign at energy $\nu_0 + J$, and one of equal rotational strength but opposite sign at energy $\nu_0 - J$. From Eq. (4), the rotational strength appears maximal when $\alpha = 90^\circ$ and $\gamma = 0$. However, this corresponds to mutually perpendicular dipoles, for which $J = 0$, so that

in practice no excitonic CD results. The actual geometry for maximal CD depends on widths of bands (see Section II,C).

The LD of each exciton state is given by

$$L_{\pm} = (\mu^2/4) [3(\cos \theta_1 \pm \cos \theta_2)^2 - 2(1 \pm \cos \alpha)] \quad (5)$$

where the θ 's are the angles between each dipole and the symmetry axis. Thus, for example, if the dipoles are mutually parallel and in-line and are also parallel to the symmetry axis, LD closely resembles absorption. However, if the dipoles are nearly perpendicular, and each is about 45° from the symmetry axis, then in contrast to absorption (which only shows a slight broadening), the LD spectrum is split, with a positive band of strength $\sim \mu^2$ at $\nu_0 + J$ and a negative band of strength $\sim \mu^2/2$ at $\nu_0 - J$. If the direction of the symmetry axis relative to the dimer coordinates is known or can be deduced, LD can be an excellent method for investigating the exciton interaction.

If the two interacting Chls are *not* in identical environments, their S_1 energies may differ even if unperturbed by the resonance interaction. Suppose the unperturbed S_1 energies are ν_0 and $\nu_0 + \Delta$, where Δ is the "differential environmental shift," then a resonance interaction of energy J mixes these two S_1 states, giving two exciton states of energies $\nu_0 + (\Delta/2) \pm (\Delta^2 + 4J^2)^{1/2}/2$. (This result follows straightforwardly from the standard theory—see, e.g., Shipman *et al.*, 1976a.) The fractional difference in absorption of the two exciton transitions is

$$(A_+ - A_-)/(A_+ + A_-) = (2J \cos \alpha)/(\Delta^2 + 4J^2)^{1/2} \quad (6)$$

and, for small J/Δ , the CD is

$$C_{\pm} = \pm 1.7 \times 10^{-5} \mu^2 \nu_0 R (\sin \alpha \cos \gamma) (J/\Delta) \quad (7)$$

If $\Delta \gg 2J$, the exciton energies closely approach the unperturbed energies, by Eq. (6) the intensity borrowing disappears (i.e., the two levels absorb equally), and by Eq. (7) the excitonic CD vanishes regardless of geometry. In other words, Δ effectively "detunes" the resonance between the two Chls, washing out all exciton effects in steady state spectra, if $\Delta \gg 2J$, the exciton splitting for the identical-environment dimer.

2. EXCITON-COUPLED AGGREGATE

If there are more than two exciton-coupled Chls in a protein complex, e.g., the three Chl *bs* in the Chl *a/b* protein, the mathematics is more complicated, but the theory is still straightforward. In brief, a J matrix is constructed in which the entry at the intersection of the i th column and the j th row is the energy of the resonance interaction between molecule i and molecule j . Obviously, the J matrix is symmetric.

Its diagonal elements are the differential environmental shifts. Diagonalization of the J matrix yields the exciton energies (N , for N Chls), and for each energy an ordered set of N numbers called an *eigenvector*. The eigenvector specifies the weighting given each Chl's wave function in the composite exciton wave function. (For the identical-environment dimer, the (+) eigenvector is $\{1/\sqrt{2}, 1/\sqrt{2}\}$, and the (-) eigenvector is $\{1/\sqrt{2}, -1/\sqrt{2}\}$.) The generalizations of Eqs. (2), (4), and (5) are, respectively,

$$A_K = \mu^2 \sum_{i,j=1}^N \hat{\mu}_i \hat{\mu}_j U_{iK} U_{jK}, \quad (8)$$

$$C_K = 1.7 \times 10^{-5} \mu^2 \nu_0 \sum_{\substack{i,j=1 \\ i>j}}^N \mathbf{R}_{ij} \hat{\mu}_i \times \hat{\mu}_j U_{iK} U_{jK} \quad (9)$$

$$L_K = (\mu^2/2) \sum_{i,j=1}^N [3(\hat{\mu}_i \cdot \hat{\epsilon})(\hat{\mu}_j \cdot \hat{\epsilon}) - \hat{\mu}_i \cdot \hat{\mu}_j] U_{iK} U_{jK}. \quad (10)$$

In Eqs. (8)–(10), $\hat{\mu}_i$ is a unit vector in the direction of the i th dipole, \mathbf{R}_{ij} is the distance vector from dipole i to dipole j , $\hat{\epsilon}$ is a unit vector in the direction of the symmetry axis, and U_{iK} is the i th element of the eigenvector for the K th exciton state.

C. Bandwidths and Degenerate-Ground-State Theory

Standard exciton theory is silent on the subject of spectral bandwidths. This is because, in ordinary molecular spectra, the widths arise primarily from electronic interaction with intramolecular vibrations, which are neglected by the standard theory. Equations (2), (4), and (5), or (8)–(10) merely give the area under each peak, whose location on the energy (or wavelength) scale is given by the corresponding exciton transition energy. Using standard theory, one provides detailed spectra only by introducing additional, *ad hoc*, parameters. It is customary to “dress” each standard exciton feature in a Gaussian “skirt”, i.e., to arbitrarily assign each band a Gaussian shape of area fixed by standard theory, but with an *ad hoc* width and skew (Philipsen and Sauer, 1972; Olson *et al.*, 1976).

In effect, standard theory's neglect of vibrations is equivalent to treating each multiatomic molecule as vibrationally monatomic. For the exciton dimer, it turns out that the theoretical problem is still tractable and, indeed is still exactly solvable, if each molecule is treated as vibrationally diatomic, i.e., the electronic motion is coupled to a single vibronic pro-

gression (Merrifield, 1963; Fulton and Gouterman, 1964). However, this approach cannot be extended readily to large molecules, nor to aggregates much larger than 2. Hemenger (1977a,b, 1978) has developed the *degenerate-ground-state* (DGS) theory that, to a very good approximation, enables one to calculate detailed spectra (absorption, CD, and LD) of reasonably large exciton-coupled aggregates of molecules as large as Chl, if one knows or can approximate the absorption spectrum of the (exciton) unperturbed Chl in the same milieu. Degenerate-ground-state theory applied to the exciton dimer gives excellent agreement with the exact one-vibronic progression theory, and for any aggregate, it accurately gives the lowest five moments of absorption and CD spectra. It has been applied in detail to at least one Chl aggregate (see Section III,A).

Degenerate-ground-state theory takes advantage of the fact that large molecules have continuous (rather than discrete) spectra. Its principal assumption is that the continuity of these spectra can be attributed to a continuum of vibronic levels within the electronic excited state. (A similar continuum in the ground state is approximated as monoenergetic, i.e., degenerate—hence the name DGS.) Using DGS theory, one calculates continuous spectra: shapes and widths of individual bands emerge automatically. Degenerate-ground-state theory accounts quantitatively for the phenomenon of “exciton narrowing”, in which the width of a resolved exciton absorption band can be narrower than that of the exciton-unperturbed molecule by a factor of as much as \sqrt{N} .

Degenerate-ground-state is clearly better than standard theory with regard to widths and shapes of bands. It also gives the band areas and exciton state energies more accurately, especially if $J \lesssim \Delta\nu$ (where $\Delta\nu$ is the width of the exciton-unperturbed absorption band). Degenerate-ground-state theory also predicts CD bands for aggregates with certain types of internal symmetry that are not expected to have any excitonic CD according to standard theory. On the other hand, DGS is somewhat more difficult to use than standard theory. Moreover, DGS theory assumes that the width of the exciton-unperturbed absorption band is largely homogeneous, i.e., more-or-less the same for any microscopic subset of Chls in a macroscopic sample. On balance, however, unless it is shown that the absorption of Chl in protein complexes is substantially broadened inhomogeneously, DGS should be viewed as an improvement over standard theory.

D. Difficulty of Experimentally Testing Exciton Theory in Chlorophyll Systems

The two requirements for testing exciton theory definitively are sufficient knowledge of structure and a suitable spectroscopic technique. The

structural requirement usually means crystals, but crystalline Chl [i.e., ethyl chlorophyllide (Chow *et al.*, 1975; Serlin *et al.*, 1975)] is optically so dense that only reflection spectroscopy is possible. Reflection spectroscopy is fraught with difficulty, but has been accomplished with crystalline porphyrin (Anex and Umans, 1964), though not Chl. As it turns out, crystallizable Chl-protein complexes (of which, so far, there are very few) are unique testing grounds for Chl excitons. This is because one expects the complex to maintain its structure whether in a crystal or in an optically dilute solution. Structure determined from the former can be used to calculate theoretical spectra that can then be compared with experimental spectra of the latter. As will become clear, even this procedure is not entirely straightforward.

III. Exciton States of Antenna Chlorophyll-Proteins

Although a substantial number of antenna Chl-protein complexes have been characterized (Thorner, 1975; Kaplan and Arntzen, Chapter 3, this volume), few so far have undergone detailed exciton theoretical analysis. Those that have are described here.

A. *Prosthecochloris Bacteriochlorophyll a*-Protein

This is the *only* Chl-protein complex whose structure is known on the basis of single-crystal X-ray diffraction (Fenna and Matthews, 1975; Fenna *et al.*, 1977; Matthews *et al.*, 1979), and therefore the only one to which the prescription of Section II,D can presently be applied. The BChl *a*-protein from *Prosthecochloris aestuarii* (the photosynthetic organism commonly grown in a mixed culture once known as *Chloropseudomonas ethylica*; see Olson, 1978) consists of 21 molecules of BChl *a*, 3 identical polypeptides each consisting of 358 amino acid residues, and possibly 1 or 2 molecules of bound water per polypeptide. These constituents are arranged in three identical subunits about an axis of threefold symmetry. In each subunit, there is a core of 7 molecules of BChl *a* about which one of the polypeptides is closely wrapped in a sack-like structure. In rough outline, the BChl *a*-protein is an oblate ellipsoid of revolution of 5.7 nm minor axis (the threefold axis) and 8.7 nm major axis. The BChl *a* core in each subunit is circumscribed by an ellipsoidal region of dimension $4.5 \times 3.5 \times 1.5$ nm. The average center-center distance of the porphyrin rings of the BChl *a* molecules is 1.2 nm for nearest neighbors in the same subunit, which is also the approximate diameter of the

porphyrin ring. However, because of the relative orientations of the seven rings, there are very few close approaches (less than, say 0.3 nm) between atoms of any two neighboring rings. Except for the fact that they lie within an angle of 40° of a mean plane, the porphyrin rings in each subunit are arrayed with no obvious symmetry.

Before the X-ray structure of the BChl *a*-protein was determined, Philipson and Sauer (1972) interpreted its low temperature absorption and CD spectra in terms of exciton interactions. Their interpretation is supported by four arguments:

1. Each of the lowest energy electronic transitions of the BChl in the protein displays a conservative CD spectrum with individual features of large rotational strength.
2. Each absorption band is split into subbands of unequal dipole strengths.
3. Each of the absorption subbands is much narrower than the absorption band of BChl *a* in solution.
4. The overall width of the lowest energy electronic absorption band in the protein (500 cm^{-1}) is consistent with the exciton bandwidth (i.e., separation of highest and lowest energy exciton levels) expected for interacting dipoles about 1.2 nm apart. Indeed, Philipson and Sauer correctly inferred this distance before it was known from the X-ray structure. Spectroscopic data obtained since then (Olson *et al.*, 1976; Whitten *et al.*, 1978, 1980) have served only to strengthen Philipson and Sauer's arguments.

In spite of the success of Philipson and Sauer's interpretation, the known X-ray structure, and the simple physics of resonance interactions, the exciton states of the BChl in the protein are still not fully characterized. The reason for this is that the exciton interactions are not the only, or even the largest, perturbation on the electronic transitions of Chl in protein complexes compared to Chl in solution. Quantitatively, this point has only been realized recently from study of the BChl *a*-protein and the LH-R-26 complex (Section III,B). The centroid of the absorption band corresponding to the $S_0 \rightarrow S_1$ transition of BChl *a* occurs at an energy lower by about 600 cm^{-1} in the protein than in an organic solvent. This is an example of the well-known absorption red shift of all Chls *in vivo*. Before the calculation of exciton effects based on the Fenna-Matthews structure (Fenna and Matthews, 1976; Pearlstein and Hemenger, 1978), it was often assumed that such effects account for much of the shift. However, the calculations explicitly showed that at most a quarter of the shift energy (150 cm^{-1}) can be attributed to exciton effects, i.e., a shift of oscillator strength to the lower energy

exciton transitions as a result of the geometry of the interacting transition dipoles. Thus, if one calculates the absorption band corresponding to the $S_0 \rightarrow S_1$ transition, one must make an *ad hoc* shift of the calculated spectrum by some 450 cm^{-1} toward lower energies to superimpose calculated and experimental centroids.

Merely shifting the calculated spectrum does not suffice to bring theory and experiment into agreement. The relative magnitudes and positions of individual peaks (i.e., individual exciton transitions) in both absorption and CD, and even signs of some CD features, are also given *incorrectly* by either DGS or standard theory. Pearlstein and Hemenger (1978) have discussed empirical ways to deal with this problem. They found (Fig. 1) that reasonably good agreement between theory and experiment can be obtained if there is an additional, nonresonant, pertur-

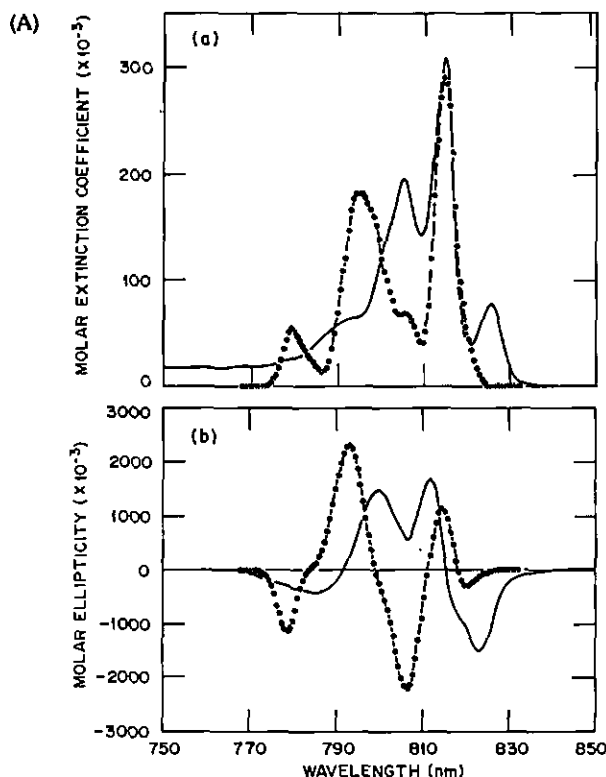
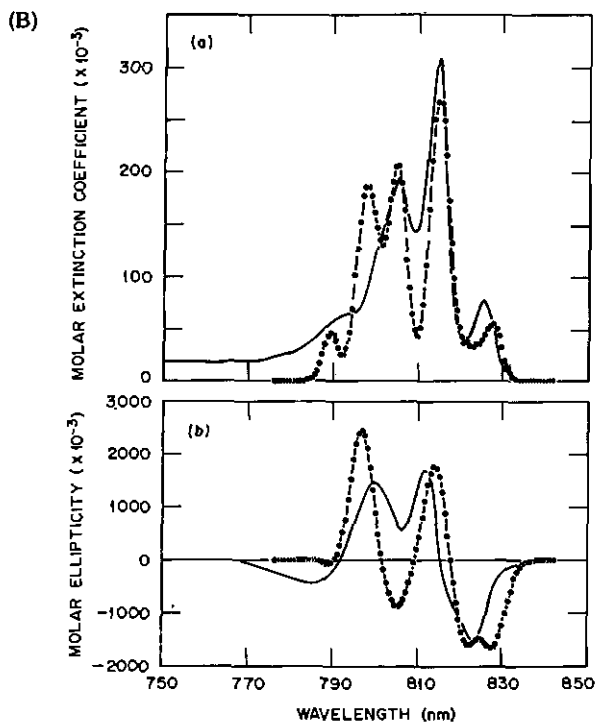

FIG. 1. Comparison of theory (points and dashed curves) and experiment (solid curves) for (a) absorption (labeled "molar extinction") and (b) circular dichroism (labeled "molar ellipticity") of BChl a -protein from *P. aestuarii* at low temperature (77 K, CD; 5 K, absorp-

bation that has at least the following two consequences: a nonexcitonic red shift of the BChl a $S_0 \rightarrow S_1$ transition energy amounting to 605 cm^{-1} and a 90° rotation of the $S_0 \rightarrow S_1$ transition dipole direction from that predicted by molecular orbital theory for "unperturbed" BChl (see Shipman, Chapter 6, this volume).

Figure 2 summarizes the present understanding of the S_1 exciton states of the BChl a -protein from *P. aestuarii*. It is not surprising that only seven exciton levels have been resolved experimentally (Whitten *et al.*, 1980), and those with difficulty, because the dipole-dipole interaction energy between BChl a molecules not in the same protein subunit is ~ 8 times weaker than that between BChls in the same subunit. (Nearest neighbor distance for BChls not in the same subunit is 2.4 nm.) The *ad hoc* red shift is 465 cm^{-1} for standard transition dipole directions and 605 cm^{-1} for dipoles rotated by 90° . As Figs. 1 and 2 show, the rotation hypothesis gives much better agreement than the standard one. Indeed,



tion). (A) Theory for $S_0 \rightarrow S_1$ transition dipole directions along molecular y axis in each BChl molecule. (B) Theory for $S_0 \rightarrow S_1$ transition dipole directions rotated by 90° (parallel to molecular x axes) in each BChl molecule.

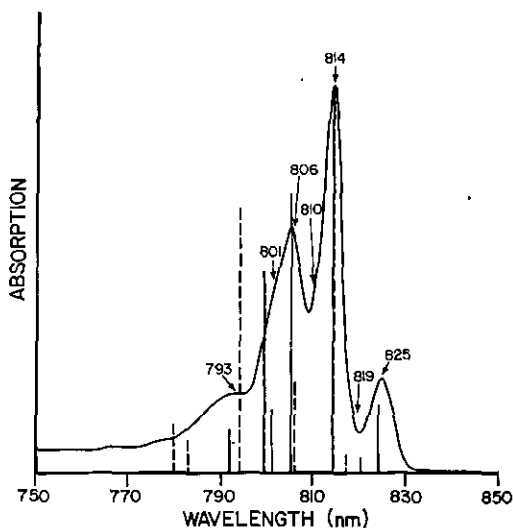

FIG. 2. Standard theory exciton spectra for S_2 exciton levels of BChl *a*-protein from *P. aestuarii*. Dashed lines are for *y* axis $S_0 \rightarrow S_1$ transition dipole directions, solid lines for *x* axis dipole directions. Curve is 5 K absorption spectrum of the protein, shown for comparison.

with rotation, only the weakest exciton transition is misplaced theoretically. It is particularly noteworthy, in view of findings with the LH-R-26 protein complex, that the theory with rotation hypothesis attributes *none* of the observed red shift to exciton effects.

Because a detailed mechanism that could account for it is unknown, one must treat the rotation hypothesis with caution pending additional confirmation. Measurement of the LD spectrum of a sample in which the BChl *a*-protein's orientation is *known* ought to provide a critical test of the hypothesis (Pearlstein and Hemenger, 1978). For microcrystalline protein of known orientation, the LD has been measured at only a single wavelength (Olson *et al.*, 1969). Recently measured low temperature LD spectra are for samples in which the macroscopic orientation of the BChl *a*-protein is unknown (Swarthoff *et al.*, 1980).

Good absorption and CD spectra in the region of the $S_0 \rightarrow S_2$ transition are available for BChl *a* both in solution and in the BChl *a*-protein (Philpson and Sauer, 1972). However, this transition has only $\sim 10\%$ of the oscillator strength of the $S_0 \rightarrow S_1$ transition, and the S_2 exciton interaction energies are correspondingly smaller. Experimentally, very little structure is resolved in the $S_0 \rightarrow S_2$ absorption and CD bands. In addition, the relative weakness of the exciton interactions increases the importance of perturbing effects (Pearlstein and Hemenger, 1978), negligible for the S_1 band, that complicate the analysis. For this reason, no detailed theoretical analysis of the S_2 exciton band has been given.

B. Light-Harvesting-R-26 Protein

The single photosynthetic organism whose pigment-protein complexes have been most intensively studied is the purple bacterium, *Rhodospseudomonas (Rp.) sphaeroides*, R-26 mutant (Thornber, 1975; Olson and Thornber, 1979). *Rhodospseudomonas sphaeroides* yielded the first (Reed and Clayton, 1968), and now best characterized (see Okamura *et al.*, Chapter 5, this volume), RC complex. It has recently been shown (Sauer and Austin, 1978) that all of the BChl *a* in *Rp. sphaeroides* R-26 occurs either in the RC or in the LH-R-26 protein, a small (molecular weight $\sim 20,000$) antenna complex that contains only two pigment molecules, both BChl *a*.

Even though its three-dimensional structure is unknown, the fact that the LH-R-26 complex contains only two molecules of BChl *a* makes it of special interest for exciton analysis. This is because for each electronic excited state of BChl *a* there is only one exciton interaction, whose magnitude (at least for S_1) can be approximately deduced from the spectra. Ambient temperature absorption, CD, and LD (of complexes oriented in stretched polyvinyl alcohol films) spectra have been determined (Bolt and Sauer, 1979, 1981; Bolt, 1980). Bolt has deduced a value of 208 cm^{-1} for the S_1 exciton-splitting energy ($2J$), i.e., $J = 104 \text{ cm}^{-1}$, from a standard-theory exciton analysis of the LD data. The CD spectrum has the symmetric, conservative form expected for a single, dimeric exciton interaction of energy, $J = 126 \text{ cm}^{-1}$, in reasonable agreement with the value deduced from LD.

From his LD analysis, Bolt deduces the two S_1 excitation transition energies to be $\nu_+ = 11,730 \text{ cm}^{-1}$ (852.5 nm), and $\nu_- = 11,527 \text{ cm}^{-1}$ (867.5 nm). The CD analysis yields $\nu_+ = 11,708 \text{ cm}^{-1}$ (854.1 nm), $\nu_- = 11,456 \text{ cm}^{-1}$ (872.9 nm). The dipole strengths of the transitions are $A_+ = 59.3 D^2$ from LD (67.1 D^2 from CD), and $A_- = 38.3 D^2$ from LD (31.0 D^2 from CD). The absolute value of the rotational strength (CD) is $1.6 \pm 1.0 D$ magneton. Bolt finds $\alpha = 78^\circ$ from LD, 68° from CD. The agreement between the LD and CD analyses is good in view of the fact that the standard theory used makes no allowance for the noticeable difference in LD and CD bandshapes.

The band-center energy is $\nu_0 = 11,629 \text{ cm}^{-1}$ (860.0 nm) from LD, or $\nu_0 = 11,582 \text{ cm}^{-1}$ (863.4 nm) from CD. Thus, in the LH-R-26 protein, BChl *a* displays a nonexcitonic red absorption shift (relative to ether solution) of $13,000 \text{ cm}^{-1} - 11,600 \text{ cm}^{-1} = 1400 \text{ cm}^{-1}$, more than twice that for BChl *a* in the *Prosthecochloris* BChl *a*-protein. Moreover, because the peak of the absorption spectrum itself occurs at $11,696 \text{ cm}^{-1}$ (855

nm), the exciton interaction actually induces an absorption *blue* shift of about 100 cm^{-1} (7 nm).

There are two significant points of similarity between the exciton interactions in the LH-R-26 protein and the *Prosthecochloris* BChl *a*-protein. First, the interaction energy in the former has about the same magnitude, $\sim 100\text{ cm}^{-1}$, as the nearest-neighbor interactions in the latter. Second, no part of the absorption red shift energy, which is an order-of-magnitude larger than J in either case, can be attributed to exciton effects in the LH-R-26 protein, nor in the *Prosthecochloris* protein if the transition moment rotation hypothesis is correct.

The S_2 LD and CD spectra of the LH-R-26 protein have also been analyzed (Bolt and Sauer, 1979; Bolt, 1980). However, the S_2 CD bands are, understandably, weaker than the S_1 (because μ^2 is less), and they deviate considerably from being conservative. The conclusions of the S_2 exciton analysis therefore must be considered tentative.

C. Chl *a/b* Protein

Green plant Chl-protein complexes are generally less well characterized than their bacterial counterparts. There is no structurally determined green plant complex, nor is there one that has only two Chls that display an exciton interaction. One of the more thoroughly studied green plant complexes is the Chl *a/b* protein (also known as CP2 or LHCP, light-harvesting Chl *a/b* protein complex), a Photosystem 2 (PSII) antenna complex that has been isolated from the chloroplasts of many species (Thornber, 1975; Shepanski, 1981). It has a molecular weight of $\sim 35,000$, and apparently includes three molecules each of Chl *a* and Chl *b*, one carotenoid, and at least one polypeptide. The Chl *a/b* protein has been the subject of a thoughtful exciton analysis by Van Metter (1977a,b), based on his ambient temperature absorption, CD, fluorescence, and fluorescence polarization spectra. More recently, Shepanski (1981) presented additional CD spectra, and some modifications to Van Metter's model of exciton interactions among the Chls of the complex.

In Van Metter's model, the large magnitude CD centered at 661 nm, which is conservative when corrected for intrinsic CD, is interpreted in terms of exciton interactions among the 3 Chl *bs*. It is argued that the lack of such CD features at longer wavelength implies that exciton interactions among the 3 Chl *as* are much weaker. Energy transfer from the Chl *bs* to the Chl *as* is efficient, as evidenced by the appearance of Chl *a* fluorescence sensitized by Chl *b* absorption and by the lack of any Chl *b* fluorescence. Rapid equilibration of electronic excitation energy

among all six pigments is indicated by the fact that their absorption and fluorescence spectra are related by Stepanov's equation (Knox and Van Metter, 1979). To explain the appearance of only two peaks (one positive, one negative) in the conservative CD, Van Metter and Shepanski propose that the Chl *b* molecules are arranged as a trimer with C_3 symmetry, i.e., the molecules are at the vertices of an equilateral triangle with their transition dipoles oriented similarly. The resulting three $S_0 \rightarrow S_1$ exciton transition dipoles are perpendicular and two are degenerate, hence the absence of a third CD peak. Another consequence of the assumed symmetry is that when the Chl *a* fluorescence is sensitized by Chl *b* absorption, a minimum in the emission spectrum of fluorescence polarization is expected near the wavelength at which Chl *b* fluorescence would be maximum (if there were no energy transfer to Chl *a*). Such a minimum is actually observed. Van Metter also describes other ways in which his model is consistent with observed fluorescence spectra.

Because so little is known of the Chl *a/b* protein's structure, Van Metter's model must be viewed as provisional with respect to mutual orientations of Chl transition dipoles. Nonetheless, it is consistent with experiment and therefore interesting. It is particularly noteworthy here that in the model, as revised by Shepanski, each pair of Chl *bs* has an S_1 exciton $J \approx -90 \text{ cm}^{-1}$, whose magnitude is comparable to the established nearest-neighbor BChl J s of the two bacterial complexes discussed earlier. Also, because the inter-Chl *a* J must be much less than the Chl *b* J , Van Metter concludes that the three Chl *bs* are mutually close, and the 3 Chl *as* are more widely dispersed. This conclusion agrees with one made many years earlier (Pearlstein, 1964) that in PSII the concentration of Chl *as* is "diluted" by an intermingling of Chl *bs* (see Sections IV, B and C).

IV. Exciton Migration from Antenna to Reaction Center

If an exciton is created in 1 fsec (see Section II), it takes nearly 10^6 times that long for it to migrate from its point of origin in an antenna complex to a RC in a typical thylakoid or chromatophore. Historically, the problem of the exciton's migration to and trapping by the RC (Franck and Teller, 1938) long predates the description of exciton states of Chl-protein complexes (Dratz *et al.*, 1967), which had to await the development of techniques for the isolation of the latter from the intact organism. Indeed, the origin of the exciton migration problem and the

concept of a "photosynthetic unit" consisting of antenna plus RC date to the same era (Emerson and Arnold, 1932a,b; Gaffron and Wohl, 1936). The historical problem—of whether a mechanism exists that can account for the (then considered brief) duration of the migration—was solved when it was shown theoretically that in lattice models of Chl arrays *in vivo* the Förster mechanism suffices (Bay and Pearlstein, 1963; Pearlstein, 1966, 1967; see also following Section). That the migration is still in any sense a problem is the result of several circumstances: (1) theoretical uncertainty about the relationship between the magnitude of J and the nature of the exciton's motion; (2) incomplete information about the structure of the Chl arrays, with regard to both the individual protein complex and the juxtaposition of complexes in membranes, and (3) new phenomena revealed by picosecond spectroscopy. The first point is dealt with in the next section, the second in Section IV,B, and the third in Section V.

A. Coupling Energy, J , and the Nature of the Motion

In the presence of intramolecular vibrations that are only weakly coupled to it, an exciton that is initially localized on one molecule undergoes purely wavelike motion. For example, in an exciton dimer, it oscillates sinusoidally between the two molecules at the frequency $2cf$. The process is reversible, and the energy is never more than instantaneously relocalized. In another and more realistic extreme, if there are exciton-coupled intramolecular vibrations whose relaxation time $\tau_r \ll (2cf)^{-1}$, an exciton initially localized on one-half of a dimer hops to the other one-half with a probability that is constant in time. For identical molecules, this process is also reversible, but the energy may be thought of as always localized on one or the other of the two molecules. In an exciton-coupled aggregate, sequential hopping transfers are described as random walks. There are also situations intermediate between the two extremes in which the exciton motion has a more complicated description.

In the older literature, these two extremes are referred to as strong coupling and very weak coupling, respectively, with reference to the magnitude of J (Simpson and Peterson, 1957; Förster, 1965). The older viewpoint held that the mechanism responsible for the two types of motion somehow differ qualitatively. Because the strong-coupling limit was defined by the appearance of exciton effects in steady state spectra, it was sometimes called simply the *exciton limit*, and ensuing energy transfer was said to be effected by an *exciton mechanism*. Similarly, because, for interacting transition dipoles, energy transfer in the very-weak-coupling limit is described by Förster's theory (Förster, 1948, 1951, 1965), the

corresponding transfer was said to be by the Förster mechanism. Such dichotomies are misleading, especially the latter because the Förster mechanism is an exciton mechanism.

More recent theoretical approaches put the description of exciton motion on a different basis (Silbey, 1976; Knox, 1977). Immediately following its creation, the motion of an exciton is wavelike (sometimes called *coherent*), and after a certain period of time it becomes hopping (or *incoherent*). Theorists differ as to the time scale on which coherence is lost; for Chl singlet excitons it is probably between 10 fsec and 1 psec (Knox, 1977; Pearlstein *et al.*, 1976). Thus, except in the emerging field of subpicosecond spectroscopy, the effects of exciton coherence on energy transfer are likely to be difficult to discern. The newer theories also confirm that, for dipole-dipole interactions, the Förster description of exciton motion is the correct one once coherence is lost.

B. Hopping Exciton Theory

Energy transfer from one molecule to another in the Förster limit has been reviewed often in the photosynthesis literature (see reviews by Knox, 1975, 1977). In brief, the hopping rate constant for transfer between the halves of an exciton dimer is

$$F = \tau_0^{-1} (R_0/R)^6 \quad (11)$$

where τ_0 is the radiative (or "natural") lifetime of S_1 , and R_0 is the critical distance given (in units of nm⁶) by Förster's formula,

$$R_0^6 = (8.785 \times 10^{17} \kappa^2/n^4) \int F(\nu)\epsilon(\nu) d\nu/\nu^4 \quad (12)$$

In Eq. (12), $\epsilon(\nu)$ is the molar extinction coefficient on a wave number scale, $F(\nu)$ is the normalized emission ($\int F(\nu) d\nu = 1$), n is the refractive index of the medium, and the orientation factor is

$$\kappa^2 = (\cos \alpha - 3 \cos \beta_1 \cos \beta_2)^2 \quad (13)$$

[see Eq. (1) for notation]. For identical molecules in nearly identical environments ($\Delta \approx 0$), the hopping is reversible because the overlap integral in Eq. (12) is the same for transfer in either direction. Equation (11) shows the inverse sixth power dependence of F on the distance R between the dipoles. This follows in Förster's theory from the inverse cubic dependence of J on R . The rate of hopping transfer (however rapid, as long as it is still describable as hopping) can never have an R^{-3} dependence, as Kenkre and Knox (1974) have discussed.

For Förster transfer over arrays of Chls, e.g., as defined by the Chl-protein complexes in a photosynthetic membrane, there is a hop-

ping rate constant between each pair of identical Chls. In terms of these rate constants, one can write down a set of coupled rate equations (collectively called a "master" equation) for the probabilities as functions of time that each Chl molecule is in the S_1 state (i.e., the exciton "resides" on that Chl). The master equation includes terms for the irreversible removal of the exciton from the antenna array, e.g., by photoconversion at the RC, fluorescence, or nonradiative decay in the antenna. The solution of the master equation for the time-dependent probabilities depends on the structure of the array, but in general can be expressed as a sum of exponential decays. Of greatest interest is the sum of the probabilities, which is itself the probability, $P(t)$, that the exciton is still in the antenna array (not yet trapped by a RC, or otherwise decayed). Thus, for an array of N Chls,

$$P(t) = \sum_{m=0}^{N-1} C_m \exp(-\gamma_m t) \quad (14)$$

where the characteristic decay-rate constants γ_m depend on the Förster F 's and other parameters of the master equation, and the weighting factors C_m depend on those as well as on how the array is excited initially. A useful quantity is the lowest moment of $P(t)$,

$$M_0 = \int_0^{\infty} P(t) dt \quad (15)$$

effectively the exciton lifetime. Physically, $P(t)$ contains most of the interesting kinetic information—one need not ask how many times the exciton "visits" a RC during its lifetime or other questions for which there are no direct experimental tests.

In general, solving the master equation is far from trivial. If the three-dimensional structure of a Chl array were known, the equation could, in principle, be solved numerically by computer. Indeed, computer studies of hopping transfer in model arrays have been done (Robinson, 1967; Altmann *et al.*, 1979; Shipman, 1980). However, it is difficult to gain insight from such studies. There is one structural situation in which the master equation can be solved analytically, i.e., without recourse to computer (thereby showing explicitly how $P(t)$ and M_0 depend on structural parameters), and another in which some features of the time-dependence of $P(t)$ can be inferred. The first of these is the regular lattice, and the second is the completely random array. Of course, the crucial question is how a real photosynthetic Chl array compares to either of these idealized situations. There are some antenna arrays in which a high degree of order in three dimensions is observed (Park and Biggins,

1964; Staehelin *et al.*, 1980; see also Kaplan and Arntzen, Chapter 3, this volume). In most arrays, there is at least substantial orientational ordering of the transition dipoles (Breton and Geacintov, 1979; see also Breton and Vermeglio, Chapter 4, this volume), and a concentration of Chl-protein complexes high enough to preclude spatial randomness. It is, therefore, reasonable to suppose that, with regard to hopping transfer, real Chl arrays are not too unlike regular lattices (of possibly complicated unit-cell structure) and that the nature of possible deviations from lattice-like transfer behavior might be suggested by the transfer kinetics of random arrays. Ultimately, of course, experiment will be the arbiter (see Sections IV,C and V).

1. LATTICE MODELS

In a lattice model, the antenna Chls are assumed to occupy the sites of a regular crystal lattice and to have a definite, fixed spatial orientation. For simplicity, it is frequently assumed that all antenna lattice sites are equivalent. The RCs, which serve to "quench" the antenna singlet excitons, also occupy lattice sites. In a lattice model, the RCs may occur regularly (i.e., form a "superlattice") or at random locations—provided each RC has an identical set of interactions with its nearest neighboring antenna Chls. The interactions of a RC with its nearest antenna neighbors in an isotropic lattice are illustrated in Fig. 3. (In an isotropic lattice, all of the Chls necessarily have the same spatial orientation.)

Three types of RC antenna coupling are distinguished in Fig. 3. The RC is said to interact "nondisruptively" (Pearlstein, 1972) with its nearest-neighbor antenna Chls if the hopping transfer between the RC and its neighbors is reversible and the rate constant has the same magnitude as that between a pair of adjacent antenna Chls. The quenching of the exciton by a nondisruptive RC is due entirely to the rapidity of conversion of the neutral excited singlet state into the charge-separated (radical ion-pair) state at the RC. (The RCs of *Rp. sphaeroides* appear to have at least approximate nondisruptive character; see Pearlstein, 1967.) A purely "disruptive" RC is one whose S_1 state lies at a sufficiently lower energy than that of the antenna Chl to "quench" the exciton (as far as the antenna is concerned) by trapping it—Förster transfer out of the RC has a negligibly small rate constant. Probably no photosynthetic RC is purely disruptive at physiological temperatures, although P700 may come close. Finally, Fig. 3 shows a "generalized quencher" (Hemenger *et al.*, 1972), one which allows both conversion and partial trapping. The generalized quencher requires three parameters for its description, against the single parameter of either the disruptive or the nondisruptive quencher. It is sufficiently general to include even a case like that of

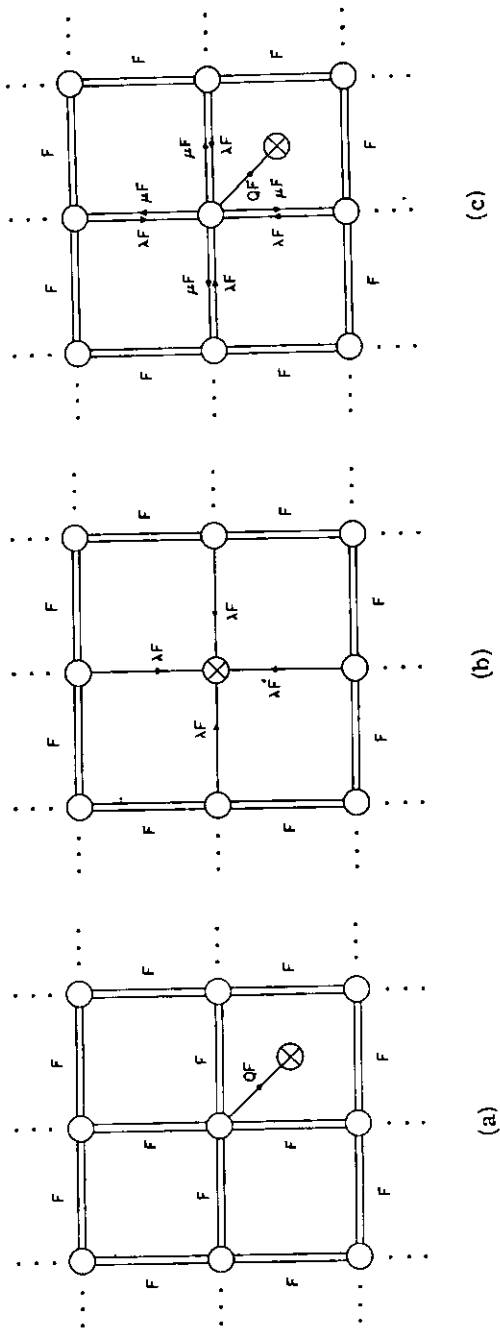

FIG. 3. Various types of quenching centers and their kinetic interactions with antenna Chl molecules, for hopping excitons. For illustrative purposes, a two-dimensional square lattice with only isotropic nearest-neighbor interactions is shown; results given in the text are more general. In each part, the central circle is the quenching site, other open circles represent antenna Chl molecules. Double connecting lines (without arrows) denote reversible excitation transfer pathways of Förster rate constant F . Single connecting lines with arrows denote irreversible transfer (of labeled rate constants). The circle with the \otimes [located, for clarity, in an interstitial position in parts (a) and (c)], represents the quantum-converting process, of rate constant QF , of the reaction center; in part (b), that last process is irrelevant to the exciton quenching. (a) Nondisruptive quenching. (b) Disruptive quenching. (c) Generalized quenching. The dimensionless quantities Q , λ , and μ are the three parameters that describe the generalized quenching.

the BChl *b*-containing bacterium *Rp. viridis*, in which the RC, although a rapid quantum converter, lies energetically uphill of the antenna BChls and so is an "antitrap" (Zankel and Clayton, 1969).

Consider a lattice of N antenna Chls per RC. The case of a purely nondisruptive quencher ($\mu = \lambda = 1$), for which there are negligible interactions between the RC and its nonnearest antenna neighbors, can be treated very generally. In that case, regardless of the range of the antenna Chl-antenna Chl interactions, the mean time for exciton quenching, or exciton lifetime, M_0 from Eq. (15), is

$$M_0 = (N/F) (Q^{-1} + A) \quad (16)$$

where F is the hopping rate constant between nearest-neighboring antenna Chls, Q is a parameter shown in Fig. 3, and A depends only on lattice parameters independent of the RC and on the initial condition (exciton starting site). Equation (16) implies that for primitive lattices of any dimension with antenna Chl-antenna Chl interactions of arbitrary range and with any initial condition, the short-range purely nondisruptive quenching of hopping excitons can be described as an additive sequence of events: There is a mean time, $(N/F)A$ to reach a RC for the first time, plus a mean time, $N/(QF)$, to be photoconverted, after the exciton has reached that center for the first time.

This simple intuitive result holds quite generally, as long as the range of direct interactions between the RC and the antenna Chls remains short. In particular, for a generalized quencher (but only nearest-neighbor interactions everywhere),

$$\langle M_0 \rangle = t_0 + (qF)^{-1} \{N\alpha - [(N-1)^2(\lambda-1)/(N\lambda)]\} \quad (17)$$

where the average is over all lattice sites, as starting sites for the exciton, weighted equally (Hemenger *et al.*, 1972). In Eq. (17), q is the number of nearest neighbors of any given lattice site, and t_0 is the value of M_0 for an exciton that starts at the quenching center itself,

$$t_0 = (QF)^{-1} [1 + (\mu/\lambda)(N-1)] \quad (18)$$

The quantity α depends on lattice parameters (see Table I). The second term on the right-hand side of Eq. (16) or Eq. (17) is the "first passage time" of random-walk theory (Montroll, 1969). In Eq. (17), $(qF)^{-1}$ is the step-time of a constant step-time random walk, and the factor in braces is the mean number of steps required to reach the RC (for the first time) from an arbitrary starting site. The exciton quenching process is said to be "quencher limited" or "diffusion limited" if the t_0 term or the random-walk term, respectively, makes the dominant contribution to $\langle M_0 \rangle$.

If detrapping is significant, that is, $\mu/\lambda \sim 1$, one has from Eq. (18) the

TABLE 1
 Values of Lattice Parameters in Eq. (17)

Number of dimensions	α	Lattice	q	c_1	c_2
1	$(N^2 - 1)/6N$	Linear	2		
2	$c_1(\ln N) + c_2$	Hexagonal	3	0.41350	0.06621
		Square	4	0.31831	0.19506
		Triangular	6	0.27566	0.23521
3	c_1	Simple cubic	6	1.51639	
		Body-centered cubic	8	1.39320	
		Face-centered cubic	12	1.34466	

at-first-sight surprising (although rigorous) result that t_0 scales with N , even though the exciton starts at the RC itself, and even in the diffusion limit. A heuristic way to understand this (for $\mu/\lambda = 1$) is the following. If the rate constant $(QF)^{-1}$ is not infinite, the exciton has a finite probability to escape the RC before photoconversion. Once it escapes, it executes a random walk whose average length before returning to the RC is exactly N steps, regardless of lattice geometry or random-walk step time. (Montroll, 1964). Thus, if the exciton initially starts at the RC, it spends on the average only $(1/N)$ th of its time there, where it is quenched with (photoconversion) rate-constant QF . As a result, its lifetime is just $(QF/N)^{-1}$, the value given by Eq. (18). If the exciton initially starts somewhere other than the RC, its first passage time to the RC must be added to the total time required for quenching [in the sense of Eq. (15)], which is the result expressed by Eq. (17).

So far, the detailed shape of $P(t)$ has not been mentioned. For hopping transfer and quenching on two- or three-dimensional lattices, the contribution of terms in the m sum of Eq. (14) is generally quite small with uniform initial excitation (all exciton starting sites equally likely) unless $m = 0$, that is, $C_0 \sim 1$, $C_m \sim 0$ for $m > 0$. When this zero-mode dominance occurs, $P(t)$ is, of course, well approximated as a single exponential, $\exp(-\gamma_0 t)$, where $\gamma_0 \approx \langle M_0 \rangle^{-1}$. The zero mode is not necessarily so dominant with other initial conditions. For example, it breaks down completely if initially only the RC itself is excited, provided that the exciton quenching is diffusion limited (Hemenger *et al.*, 1972). Even with uniform initial excitation, higher modes can contribute significantly if there is long-range quenching or slow back transfer from the quencher. (By long-range quenching is meant a situation in which exciton hopping into the RC from its non-nearest neighbors competes with nearest neighbor hops between antenna Chls. Slow back transfer signifies $\lambda \gg \mu \sim Q \sim \gamma_0/F$; see Fig. 3.)

Neither of these conditions, i.e., long-range quenching or slow back transfer, is easy to create in photosynthetic systems. For lattice models of the Chl arrays in these, the rule is therefore zero-mode dominance of hopping exciton migration and quenching (with uniform initial excitation).

Zero-mode dominance can also break down in lattices where the exciton hopping is critically anisotropic (Hemenger *et al.*, 1972). Critical anisotropy (defined later) is even less likely to occur in photosynthetic Chl "lattices" than, say, long-range quenching, but anisotropy generally is quite possible. The effects of anisotropy, including critical anisotropy, on the kinetics of incoherent exciton quenching are illustrated by the following example. Consider a simple cubic lattice in which the reversible Förster rate constants between nearest-neighboring antenna Chls are F , F , and βF along the a , b , and c directions, respectively ($0 \leq \beta \leq 1$). For simplicity, let $\mu = \lambda = 1$, so that from Eq. (17),

$$\langle M_0 \rangle = (N/F)[(1/Q) + (\alpha/6)] \quad (19)$$

From Table 1, when $\beta = 1, \alpha/6 = 0.25273$. As long as $\beta \gg 1/N$, the zero-mode remains dominant, and $\langle M_0 \rangle$ remains linear in N , although the quenching takes longer because for $1/N \ll \beta \leq 1$, $\alpha/6 = 0.25273 + (1/4\pi) \ln(1/\beta)$. If $\beta \ll 1/N$, the exciton quenching proceeds as if the cubic lattice had become a set of independent square lattices (the a - b planes): The zero-mode is again dominant (not quite as strongly) and the leading term in α is proportional to $\ln N$ (see Table I). However, if the lattice is critically anisotropic, that is, $\beta \sim 1/N$, a single decay mode no longer dominates and the random-walk part of the expression for $\langle M_0 \rangle$ differs from either purely two- or three-dimensional behavior. Physically, this result has a simple interpretation. The lattice becomes critically anisotropic when the time it takes the exciton to make a single nearest-neighbor hop along the c axis ($\sim 1/\beta F$) is comparable to the diffusion-limited exciton "lifetime" $\langle M_0 \rangle$. In other words, the exciton must make at least one out-of-plane hop to sense the three-dimensionality of the lattice.

Up to this point, the finite lifetime of the exciton due to decay channels other than RC quenching, both radiative and nonradiative, has not been included explicitly. If these other channels are all independent, first-order, and homogeneous over the antenna, they can be represented collectively by a single lifetime, τ . In Eq. (14), each γ_m calculated as if $\tau = \infty$ becomes $\gamma_m + \tau^{-1}$. When the zero-mode is dominant, one also has

$$M_0^{-1}(\tau) = M_0^{-1}(\infty) + \tau^{-1} \quad (20)$$

Equation (20) is a good approximation even in a one-dimensional lattice (Lakatos-Lindenberg *et al.*, 1972), where higher modes contribute noticeably under initial and quenching conditions for which the zero-mode is strongly dominant in three dimensions.

In a one-dimensional lattice, if the quenchers occur with a fractional concentration, c ($= 1/N$), but at random lattice sites, $\langle M_0 \rangle$ is generally much larger than it is with a quencher at every N th site, periodically (Lakatos-Lindenberg *et al.*, 1972). Also, $P(t)$ is generally highly nonexponential with quenchers placed at random. This is *not* the case for higher dimensional lattices. Both $\langle M_0 \rangle$ and $P(t)$ change little on going from periodic to random quenchers in two or three dimensions (Hemenger *et al.*, 1972). In three dimensions, P_{random} and P_{periodic} are identical to within a fractional difference of order $c^{1/2}$. Thus, for lattice models of photosynthetic Chl arrays, it is virtually immaterial to the quenching kinetics of hopping excitons whether the RCs themselves occur periodically or at random.

Because in many photosynthetic organisms there is more than one form of antenna Chl, lattice models of these Chl arrays ought somehow to take account of this fact. One proposal (Kopelman, 1976; Swenberg *et al.*, 1976) that has been made in the context of exciton transport to RCs is based on the existence, in green algae and higher green plants, of two chemically distinct antenna pigments, Chl *a* and Chl *b*. Two assumptions are made: (1) The two Chls occupy the sites of a single lattice at random, with the probability of either being at any individual site given by its fractional concentration. (2) Singlet excitation transferred from Chl *b* to Chl *a* (whose $S_0 \rightarrow S_1$ transition is of lower energy) is unlikely to return to Chl *b* during the (Chl *a*) exciton lifetime. In this model, the exciton can "percolate" through the Chl *a* sublattice, its long-range migration properties being determined by whether or not the fractional concentration of Chl *a* exceeds the critical concentration for percolation through the particular lattice. (Below the critical concentration there are only isolated clusters of Chl *a* molecules connected by nearest-neighbor pathways; above it, in an infinite lattice, there is a cluster of infinite extent.) Unfortunately, neither assumption of this percolation model is well satisfied in photosynthetic organisms. At ambient temperatures, the difference between $S_0 \rightarrow S_1$ transition energies of Chl *a* and Chl *b* in the Chl *a/b* protein complex is only $\sim 2 kT$. If a principal deduction of the Van Meter model (see III,C) is correct, that the Chl *b*'s are clustered more closely together within each protein, and if the Chl *a/b* proteins are homogeneous in structure, a lattice model would have to place the Chl *b*'s interstitially in a lattice of Chl *a*'s (in any event, in a highly nonrandom

way). It is therefore unlikely that exciton percolation is an important process in photosynthesis.

It has been suggested that photosynthetic pigments are arranged "outward" from the RC in order of increasing S_1 energies (Paillotin, 1972; Govindjee *et al.*, 1973; Seely, 1973). This includes environmentally-shifted forms of Chl *a* as well as accessory pigments. This arrangement would direct excitation energy more efficiently into the RC than a random walk over identical molecules. However, the argument overlooks two points: First, random walks on lattices in two or more dimensions are rapid enough to account for observed fluorescence lifetimes (Paillotin, 1976; Knox, 1977; see also IV,C). Second, if the excitation is trapped by the antenna in the vicinity of each RC, it would have no opportunity to visit a second RC (and therefore be wasted) if the first RC is not in the reduced state (a common occurrence at moderate to high light intensities). Interstitial placement of antenna pigments with higher S_1 energies in a (low S_1 energy) Chl *a* lattice, as suggested by the Van Metter model, seems a more plausible alternative.

2. RANDOM MODELS

If pigment molecules are placed totally at random in three dimensions, with regard to both spatial location and orientation, the situation resembles a viscous or frozen solution. Förster himself solved the problem of excitation transfer from donor (D) to acceptor (A) pigments in such a solution for the case $[D] \ll [A]$ (Förster, 1949). In that case, he found that the decay of the donor's excited state (following brief excitation) has the time dependence, $\exp[-kt^{1/2} - (t/\tau)]$, where k is a constant and τ is the D-state lifetime in the absence of A. If the energy transfer is rapid (that is, k is large), the decay is highly nonexponential, quite unlike the situation of zero-mode dominance (exponential decay) with lattice models. For pigments restricted to two dimensions but otherwise at random, the analog of the three-dimensional time dependence is $\exp[-k't^{1/2} - (t/\tau)]$, again quite nonexponential (Pearlstein *et al.*, 1979; Wolber and Hudson, 1979).

For the photosynthetic Chl arrays, if D is the principal antenna Chl and A is the RC, then the situation is not $[D] \ll [A]$ as Förster considered, but $[D] \gg [A]$ with much D-D transfer. For random pigments, the latter case has not been solved analytically, but some progress has been made (Blumen and Manz, 1979; Blumen and Zumofen, 1980). There is a tendency to speculate that the time dependences would be similar in the two cases, but that is not at all clear.

There is also a tendency to confuse the $\exp(-kt^{1/2})$ time dependence of

the $[D] \ll [A]$ random pigment problem with Smoluchowski's solution to the problem of diffusion into a sink (Smoluchowski, 1916; Montroll, 1946). The latter problem resembles that of a random walk with traps, and Smoluchowski showed that at short times there is an exponential dependence on $t^{1/2}$. However, Smoluchowski's problem, when applied to the photosynthetic case, is much more like a lattice model than a random model (Pearlstein, 1966). The $t^{1/2}$ dependence arises from summing over the higher modes ($m > 0$) in Eq. (14). Because the zero-mode is dominant, the contribution of all the higher modes together is very small, so that effects of the Smoluchowski $t^{1/2}$ dependence, in contrast to the Förster $t^{1/2}$ dependence, would be very hard to discern experimentally. It would require detecting deviations from exponentiality of at most a few percent at times ≈ 50 psec in the fluorescence decay following excitation by a weak, single picosecond pulse (see Sections IV and V).

If experiment ultimately shows deviations from exponentiality in excess of the Smoluchowski term, one might then suspect that the principal antenna Chl is not arrayed in more-or-less orderly fashion. However, this question is at least as likely to be settled by structural studies as by picosecond spectroscopy.

C. Experimental Tests of Theory

Fluorescence is the only readily available experimental monitor of the S_1 state's kinetics in photosynthetic Chl arrays. The time dependence of the fluorescence decay following excitation by a single picosecond pulse is potentially informative (Section IV,B). It is important for the analysis of the one-exciton kinetics that such picosecond experiments be extrapolated to zero-pulse energy because of nonlinear effects (Campillo *et al.*, 1977; see also Section V). It is also important that the fluorescence observed comes from the principal antenna Chl, i.e., the antenna Chl that transfers energy directly to the RC, and not from accessory antenna pigments. Transfer of energy from accessory pigments to principal antenna Chl, although certainly interesting, may not involve multiple donor (exciton) transfer, and may resemble a one-donor, many-acceptor transfer situation for which nonexponential fluorescence decay (Searle and Tredwell, 1979) is expected (Section IV,B,2).

Carefully extrapolated picosecond fluorescence experiments show no apparent deviations from exponential decay (Campillo *et al.*, 1977). It is of interest to compare theoretical and experimental exciton lifetimes. Experimentally, one determines the time constant for an exponential fluorescence decay, or more generally the time integral of the observed

decay profile. For samples whose RCs are active (i.e., not oxidized), the quantity τ^{-1} in Eq. (20) is usually negligible compared to $M_0^{-1(\infty)}$, so that the experimentally determined fluorescence lifetime can be compared directly to $\langle M_0 \rangle$ from Eq. (17).

An example of one such comparison is worked through here with lattice-model theory. It is instructive for both the general agreement between theory and experiment and for the still rather primitive nature of our understanding of exciton migration and conversion at the RC.

For chromatophores of *Rp. sphaeroides* R-26, which has only the single antenna pigment BChl *a*, the extrapolated fluorescence lifetime from single-pulse picosecond excitation is 300 ± 50 psec (Campillo *et al.*, 1977). This should be the value of $\langle M_0 \rangle$ in Eq. (17). Comparison of theory and experiment thus becomes a matter of analyzing the parameters in that equation. The t_0 term, from Eq. (18), has three parameters, μ/λ , $(QF)^{-1}$, and N . The ratio μ/λ is the relative hopping rate, back and forth, between the RC and its nearest neighboring antenna BChls (i.e., the ratio of detrapping rate constant to trapping rate constant). It may be determined empirically as the ratio of the Förster overlap integral, from Eq. (12), for RC fluorescence with antenna absorption, to the integral for antenna fluorescence with RC absorption; geometrical quantities cancel out. In the absence of such an empirical determination, one may estimate $\mu/\lambda \sim 1$ because the lowest S_1 levels of RC and antenna BChls are virtually monoenergetic. The quantity QF is the photoconversion rate of the isolated RC. The best current estimate (Holten *et al.*, 1980) is $(QF)^{-1} \approx 5$ psec. N is the number of antenna BChls per RC, so that $N = 60$. (Campillo *et al.*, 1977, take $N = 30$, the number of LH-R-26 complexes per RC. However, as argued later, it is correct to use the total number of antenna BChls, not the number of complexes.) Thus, it appears that $t_0 \approx 300$ psec, which is just the observed fluorescence lifetime. This is in accord with conclusions reached earlier (Pearlstein, 1966, 1967) that exciton migration and conversion is not diffusion limited in photosynthetic systems. It means that the exciton migration is so rapid that the exciton "visits" the RC a number of times before it is converted to the charge separated state. Note that the theory used does not require one to know the number of such visits, an experimentally inaccessible quantity. For a more detailed analysis of these points, see Pearlstein (1982).

If $\langle M \rangle \approx t_0$, the random-walk term in Eq. (17) must lie within experimental uncertainty, that is, ≤ 50 psec. Campillo *et al.* (1977) plausibly assume a two-dimensional lattice, e.g., a square lattice, for which $q = 4$ and $\alpha = 0.32 \ln N + 0.20$ from Table I. Knox (1977) has shown that for a square lattice, it is probably inconsequential whether each BChl occupies

one lattice site, or whether several BChls are bunched at each site but with the same average concentration of BChls. Thus, it is appropriate to take $N = 60$, as earlier. The parameter λ is ~ 1 for a reason similar to that why $\mu/\lambda \sim 1$ (see earlier and Fig. 3); thus the λ part of the random-walk term is negligible compared to the α part (not necessarily true for *Rp. viridis*). It follows that $F^{-1} \approx 2.2$ psec, a perfectly reasonable upper limit.

Campillo *et al.* (1977) give $\tau_0 = 18$ ns and estimate the antenna BChl-BChl $R_0 \approx 9.0$ nm (based on individual BChls, not complexes), so that from Eq. (11) and the limiting value of F^{-1} , it follows that $R \leq 2.0$ nm. (Campillo *et al.*, equating the 300-psec fluorescence lifetime to the random-walk term alone, and using $N = 30$ rather than 60, obtained $R = 3.1$ nm.) The R here is an average of the separation of dipoles within an LH-R-26 complex and the separation of nearest neighboring dipoles in two adjacent complexes. The former R value is unknown but may be ~ 1.2 nm, which is the known separation of nearest neighboring dipoles in a subunit of the *Prosthecochloris* BChl a -protein. Then linear averaging implies an upper limit of 2.8 nm for the separation of nearest neighboring dipoles in two adjacent LH-R-26 complexes in the chromatophore; squared averaging implies an upper limit of 2.6 nm. These numbers can be compared with the known 2.4 nm separation of nearest neighboring dipoles in two adjacent subunits of the *Prosthecochloris* BChl a -protein.

One concludes from this example that lattice theory and experiment are consistent, but that not too much has been learned yet because of the number of experimental uncertainties. For example, if $(QF)^{-1} \ll 5$ psec, which is possible based on current experimental results, the t_0 term may in fact make a smaller contribution to the exciton lifetime than the first-passage term. Presumably, this issue will be settled by future experiments.

In principle, it is possible to obtain additional information about the one-exciton kinetics from measurements of either steady state or time-dependent fluorescence depolarization of membranous samples. Experiments of this type show that the lowest energy antenna pigments have considerable orientational order, their $S_0 \rightarrow S_1$ dipoles being close to or in the membrane plane (see Breton and Vermeiglio, Chapter 4, this volume). However, there is as yet no theory of exciton migration on lattices (of possibly complex orientational ordering) that allows the calculation of quantities, analogous to, but more complicated than, $P(t)$, from which the time-dependent fluorescence depolarization can be determined. Such a theory exists for molecules in a frozen solution (Hemenger and Pearlstein, 1973), but that theory is clearly not relevant

to photosynthetic membranes. A theory of this sort has been given for dimers (Rahman *et al.*, 1979), and hopefully can be extended to lattices.

V. Exciton Effects in Picosecond Optical Spectra

This is a burgeoning subject that can only be touched on here. However, at least one aspect of the field, exciton collisions, is well covered in a review (Breton and Geacintov, 1980; see also Paillotin and Swenberg, 1979; Paillotin *et al.*, 1979). When two excitons collide, a strong possibility is that they then both cease to exist, their energies passing to heat, for example. With single picosecond-pulse excitation of even moderate pulse energy, exciton populations can become great enough for collisions of two singlet excitons to occur at a rate sufficient to noticeably shorten the S_1 state lifetime. Although this is a complicating artifact in the study of one-exciton kinetics, it is an interesting way to study exciton dynamics, and it may conceivably provide an independent, exciton-derived source of structural information. If a sample is excited with a train of picosecond pulses, long-lived Chl triplets created during one pulse can collide with singlet excitons created during a later pulse. This phenomenon, too, is receiving attention (Monger and Parson, 1977).

Picosecond and subpicosecond spectroscopies will possibly open other exciton-related avenues as well. One of these is the search for nonexponential fluorescence decay at early times, already mentioned (Section IV,B,2). Another is the experimental determination of the random-walk contribution to the fluorescence lifetime (Section IV,C), which would require greater precision of measurement on both intact membrane and isolated RC (Pearlstein, 1982). If that can be accomplished, a third avenue would be the search for deviations from random-walk behavior due to exciton coherence effects (Hemenger *et al.*, 1974).

VI. Exciton Effects within Reaction Center Complexes

Reaction center complexes isolated from purple bacteria contain four BChls, two Bphs and nonpigmented components (see Kaplan and Arntzen, Chapter 3, Okamura *et al.*, Chapter 5, this volume). Exciton interactions among these six RC pigments are certainly possible. If there are such interactions, they may be of importance at least as an aid in understanding RC function, i.e., primary photochemistry (see Parson and Ke, Chapter 8, this volume). In particular, if as some believe, the

primary photoelectron donor is a "special pair" of BChls, that pair's dimeric exciton interaction should give rise to observable spectroscopic effects. It is therefore of interest to ask what these effects are and whether they are, in fact, observed.

The "special-pair" hypothesis is that the primary photoelectron donor, P870 in purple bacterial RCs (P700 in green plant PSI), consists of a pair of BChls (Chls) that are closely juxtaposed with their macrocycles roughly parallel, held that way in part as a result of bonds to fifth (axial) ligands of both Mgs (Boxer and Closs, 1976; Fong and Koester, 1976; Shipman *et al.*, 1976b). The hypothesis derives from two sets of observations. First is the existence of Chls in just such paired geometries in certain organic solvent systems (verified by infrared spectroscopy and ^1H and ^{13}C NMR, Katz *et al.*, 1978), and in crystalline ethyl chlorophyllide *a* · 2H₂O (verified by X-ray diffraction analysis, Chow *et al.*, 1975). Second are the comparative ESR and ENDOR properties of a given type of Chl as monomer cation radical in a solvent and as (primary photoelectron) donor cation radical in a photosynthetic RC. For P700 and P870, the ESR lines of the latter are $1/\sqrt{2}$ narrower than those of the corresponding monomer, and several identifiable (by selective deuteration) ^1H ENDOR lines of the latter are shifted (relative to the free proton frequency) by one-half as much as those of their respective monomers (Norris *et al.*, 1979). The second set of observations can be explained (Norris *et al.*, 1971, 1979) if the unpaired electron spin of the RCs donor cation radical is more-or-less equally shared by two Chls (or BChls). The first set of observations provides specific structural models in which the explanation of the second set is realized. Thus arose the special pair hypothesis.

Theoretically, the electronic transition moments of the two Chls (or BChls) of a special pair interact resonantly (Fig. 4) to produce exciton effects (shifts or splittings) in the optical absorption spectrum (Shipman *et al.*, 1976b). These effects may also give rise to excitonic CD spectra. Certain features in the optical spectra of RC's can be interpreted in terms of such exciton effects (Reed and Ke, 1973; Vermeglio and Clayton, 1976; Vermeglio *et al.*, 1978; Rafferty and Clayton, 1979; Shvvalov and Asadov, 1979). However, at least in the case of RCs from *Rp. sphaeroides* R-26, such an interpretation leads to a considerable multiplication of hypotheses compared to an interpretation in terms of a monomeric primary donor. In these RCs, the $S_0 \rightarrow S_1$ transition appears as two absorption bands, a broad featureless one at 865 nm, and a much narrower one at 800 nm with a shoulder at ~810 nm (Feher, 1971). According to an exciton interpretation (Vermeglio and Clayton, 1976) based on the special-pair hypothesis, the two exciton components of this

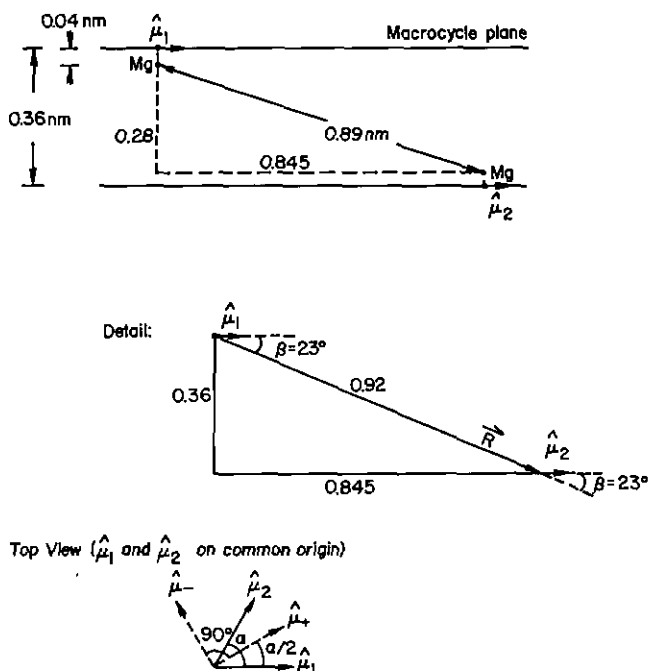

FIG. 4. Geometry of $S_0 \rightarrow S_1$ transition dipoles for Chl or BChl "special pair." $\hat{\mu}_1$ and $\hat{\mu}_2$ are unit vectors along the dipole directions for each of the two Chls. In the top view, $\hat{\mu}_+$ and $\hat{\mu}_-$ are unit vectors along the directions of the two exciton transition moment directions; the angle α is exaggerated for clarity.

transition of the special pair occur at 865 and at 810 nm (see Fig. 5), and the main absorption of the 800-nm band is attributed to the two remaining BChls of the RC (not part of the primary donor). The possibility of a weaker interaction between the two molecules of the pair, leading to a splitting of the 865-nm band, is apparently excluded by the absence of such effects in the 865-nm CD and LD bands.

This exciton interpretation is faced with the following difficulties:

1. A mechanism is needed to explain the ratio (≈ 1.7 at 77 K) of widths of the 865-nm to the 800-nm absorption band. This ratio, $\sim \sqrt{3}$, is precisely what is predicted by DGS theory if the 865-nm absorption is due to a single BChl, and the 800-nm band arises from the remaining three BChls, among which are exciton interactions of magnitude $\approx 100 \text{ cm}^{-1}$, as in antenna complexes.

2. When the RC is oxidized, chemically or photochemically, the dimeric exciton interaction of the special pair is effectively "turned off."

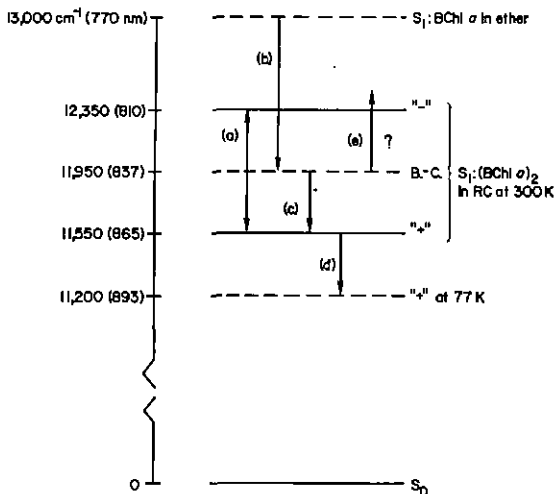

FIG. 5. Energy level diagram for special-pair BChl. (a) Exciton splitting, $2|J| = 800 \text{ cm}^{-1}$ ($J = 400 \text{ cm}^{-1}$). (b) Nonexcitonic red shift, 1050 cm^{-1} . (c) Excitonic red shift, 400 cm^{-1} . (d) Cryogenic red shift, 350 cm^{-1} . (e) Oxidation shift, absolute value $\geq 400 \text{ cm}^{-1}$.

Despite this, no absorption band of oxidized RCs occurs anywhere near 837-nm, the wavelength corresponding to the exciton band-center energy (Fig. 5), i.e., the transition energy of the remaining neutral BChl of the donor unperturbed by exciton interaction. (Differential environmental shifts of the absorptions of the two BChls in the special pair cannot be invoked to explain this anomaly, because a Δ large enough to move the absorption close to 800 nm, say, would effectively prevent the large intensity borrowing of the 865-nm band in the presence of the putative, large exciton interaction, $J = -400 \text{ cm}^{-1}$.) An additional mechanism is thus needed with a special-pair donor, but not with a monomeric donor, to account for a very substantial "oxidation shift."

3. At low temperature, the long wavelength band displays a 28-nm cryogenic red shift (Reed and Ke, 1973), while the 800-nm band merely sharpens (no shift). A red shift of exciton band-center energy should give rise to a concomitant red shift of the 810-nm absorption, which is not observed. An increase of exciton coupling strength should give rise to a concomitant blue shift of the 810-nm band, also not observed. A complex mechanism is therefore needed, with a special-pair donor, to account for this apparent precise matching of "environmental" interaction (to red shift the band center) and exciton interaction strength (to blue shift the higher energy exciton transition). With a monomeric do-

nor, only a mechanism of the first kind is needed, and no precise matching.

4. The special-pair geometry of Fig. 4, or any similar geometry with nearly parallel macrocycles that gives comparable excitonic red shift and intensity borrowing, theoretically produces an excitonic CD whose rotational strength is too small by a factor of 6 (R. M. Pearlstein, unpublished) to account for the observed strength (Reed and Ke, 1973) of the 865-nm CD band. Thus, the exciton dimer does no better than a monomeric donor (which presumably has chiral interactions with protein) in explaining this large chirality.

5. The S_1 energy of the primary donor is virtually coincident with that of the BChl in the LH-R-26 antenna complex. With a monomeric donor this coincidence can be explained by invoking one, as yet unknown, nonexcitonic red-shift mechanism. With a special pair, the donor requires a second, distinct nonexcitonic red-shift mechanism, because, unlike the exciton dimer of the LH-R-26 complex, the absorption band attributed to the special pair exciton dimer has a large excitonic red shift (Fig. 5).

If there are exciton interactions in the R-26 RC, it seems more likely they are of the small-magnitude ($\approx 100 \text{ cm}^{-1}$) type, as in all three antenna complexes so far analyzed, than of the large magnitude ($\approx 400 \text{ cm}^{-1}$) required by a special pair. The existence of the latter in the RC is itself called into question on the basis of an exciton analysis that specifically takes into account the inter-pigment geometry. It should be noted that the ENDOR lineshift argument does not quantitatively include that geometry.

Acknowledgments

I am indebted to R. S. Knox and W. W. Parson for helpful comments and criticism.

REFERENCES

- Altmann, J. A., Beddard, G. S., and Porter, G. (1979). *Ciba Found. Symp.* [N.S.] **61**, 191-197.
- Anex, B. G., and Umans, R. S. (1964). *J. Am. Chem. Soc.* **86**, 5026-5027.
- Bay, Z., and Pearlstein, R. M. (1963). *Proc. Natl. Acad. Sci. U.S.A.* **50**, 1071-1078.
- Blumen, A., and Manz, J. (1979). *J. Chem. Phys.* **71**, 4694-4702.
- Blumen, A., and Zumofen, G. (1980). *Chem. Phys. Lett.* **70**, 387-391.
- Bolt, J. (1980). Ph.D. Thesis, University of California, Berkeley.

- Bolt, J., and Sauer, K. (1979). *Biochim. Biophys. Acta* **546**, 54–63.
- Bolt, J., and Sauer, K. (1981). *Biochim. Biophys. Acta* **637**, 342–347.
- Boxer, S. G., and Closs, G. L. (1976). *J. Am. Chem. Soc.* **98**, 5406–5408.
- Breton, J., and Geacintov, N. E. (1979). *Ciba Found. Symp.* [N.S.] **61**, 217–233.
- Breton, J., and Geacintov, N. E. (1980). *Biochim. Biophys. Acta* **594**, 1–32.
- Butler, W. L. (1979). *Ciba Found. Symp.* [N.S.] **61**, 237–252.
- Campillo, A. J., Kollman, V. H., and Shapirq, S. L. (1976). *Science* **193**, 227–229.
- Campillo, A. J., Hyer, R. C., Monger, T. G., Parson, W. W., and Shapiro, S. L. (1977). *Proc. Natl. Acad. Sci. U.S.A.* **74**, 1997–2001.
- Chang, J. C. (1977). *J. Chem. Phys.* **67**, 3901–3909.
- Chow, H., Serlin, R., and Strouse, C. E. (1975). *J. Am. Chem. Soc.* **97**, 7230–7237.
- Davydov, A. S. (1971). "Theory of Molecular Excitons." Plenum, New York.
- Dexter, D. L., and Knox, R. S. (1965). "Excitons." Wiley (Interscience), New York.
- Dratz, E. A., Schultz, A. J., and Sauer, K. (1967). *Brookhaven Symp. Biol.* **19**, 303–318.
- Duysens, L. N. M. (1952). Doctoral Thesis, State University, Utrecht, The Netherlands.
- Duysens, L. N. M. (1964). *Prog. Biophys.* **14**, 1–104.
- Emerson, R., and Arnold, W. A. (1932a). *J. Gen. Physiol.* **15**, 391–420.
- Emerson, R., and Arnold, W. A. (1932b). *J. Gen. Physiol.* **16**, 191–204.
- Fehér, G. (1971). *Photochem. Photobiol.* **14**, 373–387.
- Fenna, R. E., and Mathews, B. W. (1975). *Nature (London)* **258**, 573–577.
- Fenna, R. E., and Mathews, B. W. (1976). *Brookhaven Symp. Biol.* **28**, 170–182.
- Fenna, R. E., Ten Eyck, L. F., and Mathews, B. W. (1977). *Biochem. Biophys. Res. Commun.* **75**, 751–756.
- Fong, F. K., and Koester, V. J. (1976). *Biochim. Biophys. Acta* **423**, 52–64.
- Förster, T. (1948). *Ann. Phys. (Leipzig)* [6] **2**, 55–75.
- Förster, T. (1949). *Z. Naturforsch., A* **4**, 321–327.
- Förster, T. (1951). "Fluoreszenz Organischer Verbindungen." Vandenhoeck & Ruprecht, Göttingen.
- Förster, T. (1965). In "Modern Quantum Chemistry" (O. Sinanoglu, ed.), Part 3, pp. 93–137. Academic Press, New York.
- Franck, J., and Teller, E. (1938). *J. Chem. Phys.* **6**, 861–872.
- Frank, H. A., McLean, M. B., and Sauer, K. (1979). *Proc. Natl. Acad. Sci. U.S.A.* **76**, 5124–5128.
- Fulton, R. L., and Gouterman, M. (1964). *J. Chem. Phys.* **41**, 2280–2286.
- Gaffron, H., and Wohl, K. (1936). *Naturwissenschaften* **24**, 81–90, 103–107.
- Govindjee, and Govindjee, R. (1975). In "Bioenergetics of Photosynthesis" (Govindjee, ed.), pp. 1–50. Academic Press, New York.
- Govindjee, Papageorgiou, G., and Rabinowitch, E. (1973). In "Practical Fluorescence: Theory, Methods, and Techniques" (G. G. Guilbault, ed.), pp. 543–575. Dekker, New York.
- Hemenger, R. P. (1977a). *J. Chem. Phys.* **66**, 1795–1801.
- Hemenger, R. P. (1977b). *J. Chem. Phys.* **67**, 262–264.
- Hemenger, R. P. (1978). *J. Chem. Phys.* **68**, 1722–1728.
- Hemenger, R. P., and Pearlstein, R. M. (1973). *J. Chem. Phys.* **59**, 4064–4072.
- Hemenger, R. P., Pearlstein, R. M., and Lakatos-Lindenberg, K. (1972). *J. Math. Phys.* **13**, 1056–1063.
- Hemenger, R. P., Lakatos-Lindenberg, K., and Pearlstein, R. M. (1974). *J. Chem. Phys.* **60**, 3271–3277.
- Holten, D., Hoganson, C., Windsor, M. W., Schenck, C. C., Parson, W. W., Migus, A., Fork, R. L., and Shank, C. V. (1980). *Biochim. Biophys. Acta* **592**, 461–477.

- Kasha, M. (1963). *Radiat. Res.* **20**, 55-71.
- Kasha, M., Rawls, H. R., and El-Bayoumi, M. A. (1965). *Pure Appl. Chem.* **11**, 371-392.
- Katz, J. J., Shipman, L. L., Cotton, T. M., and Janson, T. R. (1978). In "The Porphyrins" (D. Dolphin, ed.), Vol. 5, pp. 401-458. Academic Press, New York.
- Kenkre, V. M., and Knox, R. S. (1974). *Phys. Rev. Lett.* **33**, 803-806.
- Knox, R. S. (1963). "Theory of Excitons." Academic Press, New York.
- Knox, R. S. (1975). In "Bioenergetics of Photosynthesis" (Govindjee, ed.), pp. 183-221. Academic Press, New York.
- Knox, R. S. (1977). *Top. Photosynth.* **2**, 55-97.
- Knox, R. S., and Van Metter, R. L. (1979). *Ciba Found. Symp.* [N.S.] **61**, 177-186.
- Kopelman, R. (1976). *Top. Appl. Phys.* **15**, 298.
- Lakatos-Lindenberg, L., Hemenger, R. P., and Pearlstein, R. M. (1972). *J. Chem. Phys.* **56**, 4852-4867.
- Levanon, H., and Norris, J. R. (1978). *Chem. Rev.* **78**, 185-198.
- Matthews, B. W., Fenna, R. E., Bolognesi, M. C., Schmid, M. F., and Olson, J. M. (1979). *J. Mol. Biol.* **131**, 259-285.
- Merrifield, R. E. (1963). *Radiat. Res.* **20**, 154-158.
- Monger, T. G., and Parson, W. W. (1977). *Biochim. Biophys. Acta* **360**, 393-407.
- Montroll, E. W. (1946). *J. Chem. Phys.* **14**, 202-211.
- Montroll, E. W. (1964). *Proc. Symp. Appl. Math.* **16**, 193-220.
- Montroll, E. W. (1969). *J. Math. Phys.* **10**, 753-765.
- Norris, J. R., Uphaus, R. A., Crespi, H. L., and Katz, J. J. (1971). *Proc. Natl. Acad. Sci. U.S.A.* **68**, 625-629.
- Norris, J. R., Scheer, H., and Katz, J. J. (1979). In "The Porphyrins" (D. Dolphin, ed.), Vol. 4, pp. 159-195. Academic Press, New York.
- Olson, J. M. (1978). *Int. J. Syst. Bacteriol.* **28**, 128-129.
- Olson, J. M., and Thornber, J. P. (1979). *Membr. Proteins* **2**, 279-340.
- Olson, R. A., Jennings, W. H., and Olson, J. M. (1969). *Arch. Biochem. Biophys.* **129**, 30-41.
- Olson, J. M., Ke, B., and Thompson, K. H. (1976). *Biochim. Biophys. Acta* **430**, 524-537.
- Paillotin, G. (1972). *J. Theor. Biol.* **36**, 223-235.
- Paillotin, G. (1976). *J. Theor. Biol.* **58**, 219-235.
- Paillotin, G., and Swenberg, C. E. (1979). *Ciba Found. Symp.* [N.S.] **61**, 201-209.
- Paillotin, G., Swenberg, C. E., Breton, J., and Geacintov, N. E. (1979). *Biophys. J.* **25**, 513-533.
- Park, R. B., and Biggins, J. (1964). *Science* **144**, 1009-1010.
- Pearlstein, R. M. (1964). *Proc. Natl. Acad. Sci. U.S.A.* **52**, 824-830.
- Pearlstein, R. M. (1966). Ph.D. Thesis, University of Maryland, College Park.
- Pearlstein, R. M. (1967). *Brookhaven Symp. Biol.* **19**, 8-14.
- Pearlstein, R. M. (1972). *J. Chem. Phys.* **56**, 2431-2442.
- Pearlstein, R. M. (1982). *Photochem. Photobiol.* **35**, 835-844.
- Pearlstein, R. M., and Hemenger, R. P. (1978). *Proc. Natl. Acad. Sci. U.S.A.* **75**, 4920-4924.
- Pearlstein, R. M., Lindenberg, K., and Hemenger, R. P. (1976). In "Excited States of Biological Molecules" (J. B. Birks, ed.), pp. 591-600. Wiley, New York.
- Pearlstein, R. M., Van Nostrand, F., and Nairn, J. A. (1979). *Biophys. J.* **26**, 61-72.
- Philipson, K. D., and Sauer, K. (1972). *Biochemistry* **11**, 1880-1885.
- Rafferty, C. N., and Clayton, R. K. (1979). *Biochim. Biophys. Acta* **546**, 189-206.
- Rahman, T. S., Knox, R. S., and Kenkre, V. M. (1979). *Chem. Phys.* **44**, 197-211.
- Reed, D. W., and Clayton, R. K. (1968). *Biochem. Biophys. Res. Commun.* **30**, 471-475.
- Reed, D. W., and Ke, B. (1973). *J. Biol. Chem.* **248**, 3041-3045.
- Robinson, G. W. (1967). *Brookhaven Symp. Biol.* **19**, 16-45.

- Sauer, K. (1975). In "Bioenergetics of Photosynthesis" (Govindjee, ed.), pp. 115-181. Academic Press, New York.
- Sauer, K. (1978). *Acc. Chem. Res.* **11**, 257-264.
- Sauer, K., and Austin, L. A. (1978). *Biochemistry* **17**, 2011-2019.
- Searle, G. W. F., and Tredwell, C. J. (1979). *Ciba Found. Symp.* [N.S.] **61**, 257-277.
- Seely, G. R. (1973). *J. Theor. Biol.* **40**, 173-187.
- Serlin, R., Chow, H., and Strouse, C. E. (1975). *J. Am. Chem. Soc.* **97**, 7237-7242.
- Shepanski, J. F., and Knox, R. S. (1981). *Isr. J. Chem.* **21**, 325-331.
- Shipman, L. L. (1980). *Photochem. Photobiol.* **31**, 157-167.
- Shipman, L. L., Norris, J. R., and Katz, J. J. (1976a). *J. Phys. Chem.* **80**, 877-882.
- Shipman, L. L., Cotton, T. M., Norris, J. R., and Katz, J. J. (1976b). *Proc. Natl. Acad. Sci. U.S.A.* **73**, 1791-1794.
- Shuvalov, V. A., and Asadov, A. A. (1979). *Biochim. Biophys. Acta* **545**, 296-308.
- Silbey, R. (1976). *Annu. Rev. Phys. Chem.* **27**, 203-223.
- Simpson, W. T., and Peterson, D. L. (1957). *J. Chem. Phys.* **26**, 588-593.
- Smoluchowski, M. W. (1916). *Phys. Z.* **17**, 557, 585.
- Staelin, L. A., Golecki, J. R., and Drews, G. (1980). *Biochim. Biophys. Acta* **589**, 30-45.
- Swarthoff, T., de Grooth, B. G., Meiburg, R. F., Rijgersberg, C. P., and Amesz, J. (1980). *Biochim. Biophys. Acta* **593**, 51-59.
- Swenberg, C. E., Dominijanni, R., and Geacintov, N. E. (1976). *Photochem. Photobiol.* **24**, 601-604.
- Sybesma, C. (1977). "An Introduction to Biophysics." Academic Press, New York.
- Thorner, J. P. (1975). *Annu. Rev. Plant Physiol.* **26**, 127-158.
- Tinoco, I. (1963). *Radiat. Res.* **20**, 133-139.
- Tinoco, I., and Cantor, C. R. (1970). *Methods Biochem. Anal.* **18**, 81-203.
- Van Metter, R. L. (1977a). *Biochim. Biophys. Acta* **462**, 642-658.
- Van Metter, R. L. (1977b). Ph.D. Thesis, University of Rochester, Rochester, New York.
- Vermeglio, A., and Clayton, R. K. (1976). *Biochim. Biophys. Acta* **449**, 500-515.
- Vermeglio, A., Breton, J., Paillotin, G., and Cogdell, R. (1978). *Biochim. Biophys. Acta* **501**, 514-530.
- Weiss, C., Jr. (1972). *J. Mol. Spectrosc.* **44**, 37-80.
- Whitten, W. B., Nairn, J. A., and Pearlstein, R. M. (1978). *Biochim. Biophys. Acta* **503**, 251-262.
- Whitten, W. B., Olson, J. M., and Pearlstein, R. M. (1980). *Biochim. Biophys. Acta* **591**, 203-207.
- Wolber, P. K., and Hudson, B. S. (1979). *Biophys. J.* **28**, 197-210.
- Wong, D., Merkelo, H., and Govindjee (1981). *Photochem. Photobiol.* **33**, 97-101.
- Zankel, K. L., and Clayton, R. K. (1969). *Photochem. Photobiol.* **9**, 7-15.

Primary Photochemical Reactions

WILLIAM W. PARSON
BACON KE

I. Introduction: General Considerations.....	332
A. Photo-oxidation of Chlorophylls.....	332
B. Requirements for Fast Electron Transfer.....	334
C. The Problem of Preventing Back Reactions.....	336
D. Experimental Approaches.....	338
II. Photosynthetic Bacteria.....	339
A. General Scheme.....	339
B. Quinone Acceptors Q_A and Q_B	340
C. The Initial (or Intermediate) Electron Acceptor Complex, I.....	341
D. Electron Transfer between the Bacteriochlorophyll and Bacteriopheophytin of I.....	345
E. Triplet States.....	348
F. Charge Transfer within the Reaction Center Bacteriochlorophyll Dimer.....	352
III. Green Plants.....	354
A. General Scheme.....	354
B. Chloroplast Photosystem I.....	356
C. Chloroplast Photosystem II.....	369
References.....	379

ABBREVIATIONS

BChl	Bacteriochlorophyll
Bph	Bacteriopheophytin
Chl	Chlorophyll
Cyt	Cytochrome
E_m	Midpoint redox potential (referred to H^+/H_2 at pH 7)
ENDOR	Electron-nuclear double resonance
ESR	Electron spin (paramagnetic) resonance
HOMO	Highest normally filled molecular orbital
ISC-A (B)	Iron-sulfur center A (B)
LUMO	Lowest normally unoccupied molecular orbital
Ph	Pheophytin
PSI(II)	Chloroplast photosystem I(II)
RC	Reaction center
TSF-I(II)	<i>Triton subchloroplast fragments enriched in the RCs of PSI (II)</i>

ABSTRACT

The photochemical reactions of photosynthetic bacteria and plants all depend on the principle that when bacteriochlorophyll or chlorophyll is excited with light, it becomes a strong reductant. The excited molecule transfers an electron to a neighboring molecule, which appears to be a second bacteriochlorophyll in the case of bacteria, a second chlorophyll in chloroplast photosystem I, and a pheophytin in chloroplast photosystem II. This first step is completed within a few picoseconds. It is followed rapidly by the movement of an electron from the initial acceptor to a second, and from the second acceptor in turn to a third. The electron is thus removed quickly from the region of the oxidized bacteriochlorophyll or chlorophyll, preventing wasteful back reactions between the electron donor and acceptor. The chains of early electron donors and acceptors have been studied in bacteria and the two plant photosystems, by measuring optical absorbance changes and electron spin resonance signals that reflect the oxidation or reduction of the carriers. In some cases, the reduced electron acceptors have been trapped by blocking their reactions with subsequent acceptors. Because the initial reactions are extremely fast, studies on primary photochemistry require the use of techniques with very high time resolution.

I. Introduction: General Considerations

A. Photo-oxidation of Chlorophylls

The primary photochemical reactions in photosynthetic bacteria and in the two photosystems of green plants all appear to be basically alike. They all depend on the fact that when chlorophyll (Chl) or bacteriochlorophyll (BChl) is raised to an excited singlet state, the molecule becomes a much stronger and more reactive electron donor than it is in the ground state. An electron in the lowest normally unoccupied molecular orbital (LUMO) is bound less tightly than one in the highest normally filled orbital (HOMO), and it is readily transferred to a neighboring electron acceptor (Fig. 1). The midpoint redox potential (E_m) of the excited molecule is more negative than that of the unexcited molecule by approximately $h\nu/e$, where $h\nu$ is the excitation energy and e is the electronic charge. The E_m for the one-electron oxidation of unexcited BChl in organic solvents is about +0.5 V (Fuhrhop and Mauzerall, 1969; Fajer *et al.*, 1974), and since $h\nu$ is about 1.6 eV, the E_m in the excited state is approximately -1.1 V. But similar considerations must apply to hemes, and indeed to any oxidizable molecule. What is special about Chl and BChl? The answer to this hinges partly on the fact that excited molecules can decay by a variety of competing pathways (Fig. 1). Electron transfer can occur with a high quantum yield only if competing processes are restricted. Chl and BChl are better suited for photochemical electron transfer than the hemes because their excited singlet states are longer-lived. In the hemes, interactions between the central Fe and

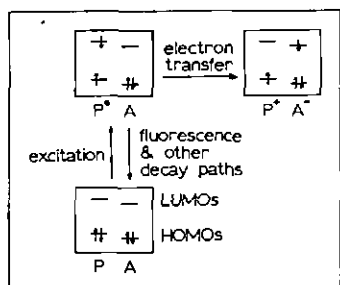

FIG. 1. Basic mechanism of the primary photochemical electron transfer reactions. Key: P, Chl, BChl, or a (Chl)₂ or (BChl)₂ dimer; A, electron acceptor that is either another molecule of Chl or BChl, or the corresponding Ph. The horizontal lines represent the highest filled molecular orbitals (HOMOs) and the lowest unfilled molecular orbitals (LUMOs); short vertical arrows represent electrons. The LUMO is 1.3–1.6 eV above the HOMO in energy. Excitation of P creates an excited singlet state (P*). P* can decay by fluorescence or radiationless relaxation, or by intersystem crossing to a triplet state (not shown), or it can transfer an electron to A. Electron transfer forms cationic and anionic free radicals (P⁺ and A⁻). The reduction of A by P* is downhill thermodynamically, whereas the reduction by P would be far uphill.

the porphyrin ring cause extremely rapid quenching of the excited state. The Mg of BChl and Chl does not have this effect. (See chemical structures in Shipmann, Chapter 6, and Rebeiz and Lascelles, Chapter 15, this volume.) Chl and BChl have fluorescence lifetimes similar to those of the Mg-free analogs, pheophytin (Ph) and bacteriopheophytin (Bph).

One of the processes that compete with photochemical electron transfer is fluorescence, and this leads to an interesting dilemma (for a discussion of fluorescence *in vivo*, see Lavorel and Etienne, 1977). Other things being equal, the rate constant for fluorescence (the reciprocal of the natural radiative lifetime of the excited state) is proportional to the extinction coefficient for excitation of the molecule from the ground state to the excited state. Strong absorbers are strong emitters. An effective photochemical system has to have a large extinction coefficient, if the excited state is to be generated with a high probability. Bacterial reaction centers (RCs), as an example, have an extinction coefficient of $1.2 \times 10^5 \text{ M}^{-1} \text{ cm}^{-1}$ in their long wavelength absorption band (Straley *et al.*, 1973); this is about six times as large as the extinction coefficient for the α band of a *c*-type cytochrome. Why then, do excited RCs not decay very rapidly by fluorescence? Part of the answer to this is that the rate constant for fluorescence also depends inversely on the wavelength of the emission. The relatively low energy of the excited states of Chl and BChl (Chl* and BChl*) thus helps to check the wasteful decay of the excited states by fluorescence. Moving the absorption band of the RC to longer wavelengths also increases the possibilities of using other pigments as an antenna to feed excitations to the RC. These benefits have their costs, however. The lower the energy of the excited state, the

smaller the amount of free energy that can be trapped photochemically. In addition, the probability of nonradiative decay of the excited state increases as the energy of the excited state decreases.

BChl* in solution has a lifetime of about 2 nsec (Goedheer, 1973; Holten *et al.*, 1980), and Chl* has a lifetime of about 6 nsec (Brody and Rabinowitch, 1957; Butler and Norris, 1962). In the case of BChl*, radiationless relaxation probably accounts for about 60% of the decay; intersystem crossing, about 30%; and fluorescence, about 10%. The sum of the rate constants for these decay paths probably cannot be significantly lower in the photosynthetic RCs than it is in solution. This means that electron transfer can occur efficiently only if its rate constant is much greater than $5 \times 10^8 \text{ sec}^{-1}$. We can refine this limit if we know something about the actual efficiency.

The quantum efficiency of the primary electron transfer reactions is astonishingly high, both in bacteria and in the two chloroplast photosystems. Electron transfer occurs virtually every time the photosynthetic apparatus absorbs a photon. In RCs isolated from *Rhodospseudomonas (Rp.) sphaeroides*, the measured quantum yield is $102 \pm 4\%$ (Wraight and Clayton, 1973)! If electron transfer competes successfully with wasteful quenching processes at least 98% of the time, and if the overall rate constant for quenching is approximately $5 \times 10^8 \text{ sec}^{-1}$, the rate constant for electron transfer must be greater than $2.5 \times 10^{10} \text{ sec}^{-1}$. The rate constant would have to be higher than this to allow for any reversibility of the forward electron transfer reaction.

As we shall discuss later, the actual rate constants for the initial electron transfer reactions have not yet been measured definitively. All of the attempts that have been made to date have probably given only lower limits. In the chloroplast photosystems, the rate constants appear to be at least $5 \times 10^{10} \text{ sec}^{-1}$ (Fenton *et al.*, 1979; Shuvalov *et al.*, 1979b, 1980); in bacterial RCs, the lower limit is approximately $1 \times 10^{12} \text{ sec}^{-1}$ (Holten *et al.*, 1980).

B. Requirements for Fast Electron Transfer

The great speed of the initial electron transfer reactions requires that the primary electron donor and acceptor (P and A) be quite close together. The rate constant for an electron transfer reaction depends strongly (quadratically) on orbital overlap between the reactants, and the orbital overlap falls off exponentially with distance (Hopfield, 1974; Jortner, 1976; Blankenship and Parson, 1979a; Redi and Hopfield, 1980).

Rates of electron transfer reactions also are controlled by the Franck-Condon principle, which says that the energy, angular momentum, and nuclear geometry of the system cannot change during the electron transfer (Hopfield, 1974; Jortner, 1976; Blankenship and Parson, 1979a; DeVault, 1980; Sarai, 1980). If the reaction is exothermic, the release of energy must occur during vibrational relaxation of the products after the electron transfer. This means that before the electron transfer can occur, the reactants must take on the nuclear geometry of a vibrationally excited state of the products. In general, this will not be identical with the geometry of the ground vibrational state of the reactants, and an activation energy will be needed in order to put the reactants into the proper geometry (Fig. 2). One of the most striking features of the primary photosynthetic reactions, in addition to their speed and efficiency, is that their activation energies are essentially zero. The electron transfer continues to occur rapidly and efficiently even at temperatures near 4°K (Peters *et al.*, 1978; Schenck *et al.*, 1981b). The energy difference between the states P^*A and P^+A^- evidently is close to optimal, relative to the changes in nuclear geometry that result from the electron transfer (Fig. 2).

How much of a change in geometry does one expect to result from the oxidation of Chl or BChl? The geometry of the molecule itself will probably change very little. Oxidation is likely to cause very small changes in the lengths of a number of different bonds, rather than a major change in any individual bond. This is because the charge on the oxidized molecule is delocalized extensively over the π electron system (Fajer *et al.*, 1974). The situation is quite different from that in the cytochromes, where oxidation causes more localized changes in electron density at the Fe atom. It is possible, however, that the oxidation of BChl or Chl in the photosynthetic RCs causes a movement of the molecule as a whole with respect to its surroundings. If the complex that undergoes photo-oxidation is a dimer of BChls or Chls (as it appears to be in bacterial RCs, but see Pearlstein, Chapter 7, this volume), the two molecules of the dimer are likely to move closer together after the oxidation (Warshel, 1980). Unfortunately, we do not know enough about the structure of the RC to predict the magnitudes of such movements. If the movements are small, the great speed of the initial electron transfer reaction implies that the energies of P^*A and P^+A^- are very close together.

The speed of the initial electron transfer reactions also seems to require that the reactions occur directly from an excited singlet state, as illustrated in Fig. 1. Intersystem crossing to the triplet state has a rate

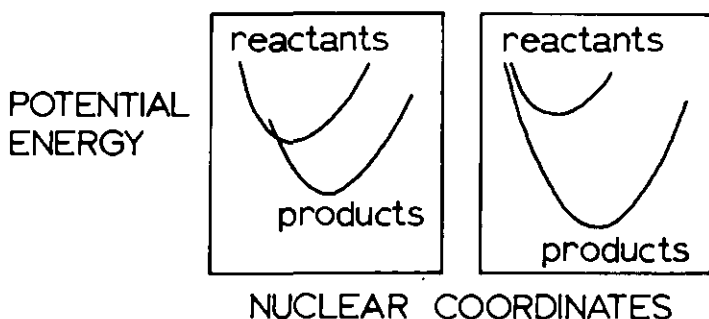

FIG. 2. Schematic illustration of the role of the Franck-Condon principle in electron transfer. The curves show the energies of the reactants (e.g., P^*A) and the products (e.g., P^+A^-), as a function of the nuclear geometries. The abscissa could represent the length of a particular bond, whose mean length is somewhat greater in the products than it is in the reactants. The left- and right-hand parts of the figure represent situations in which products have different electronic energies relative to the energy of the reactants. The Franck-Condon principle states that the nuclear geometry cannot change during the actual electron transfer; this means that the reaction will occur only where the curves for the reactants and products intersect. The frequency with which the reactants reach such an intersection depends on the difference between the mean geometries of the reactants and products, on the difference between the electronic energies of the reactants and products, and on the temperature. For the curves that are shown, the reaction on the left will be facile and nearly temperature-independent. The reaction on the right will have a large activation energy. This figure is highly schematic, because the reactants and products generally contain many vibrating bonds, rather than the one bond illustrated here, and the vibrational energy levels are quantized. "Intersections" of the reactant and products curves can be expressed more rigorously in terms of overlap between the nuclear wave functions (see Jortner, 1976; DeVault, 1980; Sarai, 1980.)

constant of about $2 \times 10^8 \text{ sec}^{-1}$ in Chl and BChl (Parson and Cogdell, 1975), and this is at least 10^3 times too slow to allow the triplet states to be intermediates in the electron transfer. One can imagine ways of facilitating intersystem crossing, such as interactions with paramagnetic species like Fe, but there is no evidence that effects of this type occur in the RCs. Removal of the Fe from bacterial RCs has little or no effect on the initial electron transfer reaction (Blankenship and Parson, 1979b). Additional arguments that the electron transfer occurs from a singlet state are discussed later.

C. The Problem of Preventing Back Reactions

One reason that the question of triplet states arises is that most of the photo-oxidations of Chl and related molecules in solution occur from

triplet states (Holten *et al.*, 1976, 1978a; Andreeva *et al.*, 1978). There are two factors underlying this. First, the lifetimes of the triplet states in solution are on the order of 10^{-4} – 10^{-3} sec, which is more than 10^4 times longer than the lifetimes of the excited singlet states. The triplet species thus have a much greater opportunity to collide with an electron acceptor. This is not really germane to the photosynthetic RCs, where the close proximity of P and A can insure an opportunity for reactions in the singlet state. Second and more importantly, the radical pairs that form by electron transfer from excited singlet states in solution tend to decay immediately by reverse electron transfer reactions (Holten *et al.*, 1978a). Referring to Fig. 1, one can see that the return of an electron from A^- to the HOMO of P is strongly favorable thermodynamically. Back reactions of this sort can occur if the spins of the unpaired electrons on P^+ and A^- are antiparallel (as shown in Fig. 1), but not if they are parallel (as they would be if P^+A^- formed from a triplet state of P). Back reactions from triplet radical pairs to the singlet ground state (PA) require a change of electron spin angular momentum which is "forbidden."

How are wasteful back reactions of P^+A^- prevented in the photosynthetic RCs, if the initial reactions there occur from excited singlet states? The answer to this question is not clear, although several possible solutions have been suggested (Blankenship and Parson, 1978, 1979a; Holten *et al.*, 1978a; Redi and Hopfield, 1980). One possibility is that P^+ and A^- are pulled away from each other very rapidly, perhaps by interactions with other charged groups in the RC. Another possibility is that the spatial properties of the molecular orbitals of P and A are such that there is good overlap between the LUMOs of P and A, but poor overlap between the LUMO of A and the HOMO of P. The overlap between the two LUMOs would allow fast electron transfer from P^* to A, and the poor overlap between the orbitals of different type would prevent back reactions between A^- and P^+ (see Fig. 1). A third possibility is that the back reaction is slow because it is highly exothermic compared to the initial electron transfer reaction from P^* to A (Fig. 1). Franck-Condon factors can limit the rates of strongly exothermic reactions, as illustrated in Fig. 2.

All of these possibilities for limiting the rates of back reactions between P^+ and A^- depend on the idea that P^+ and A^- are held in the RC in a tightly controlled geometry. The rapid back reactions that occur with radical pairs in solution presumably occur because the two radicals can move relatively freely with respect to each other and with respect to molecules of the solvent.

Perhaps the most effective way to minimize back reactions is to have a chain of electron acceptors (A_1, A_2, A_3, \dots) that are arranged to conduct electrons rapidly away from P^+ (Fig. 3). Forward electron transfer from one acceptor to the next can be made rapid by positioning the electron carriers close together and by optimizing the drop in energy that occurs on each step. The probability of a back reaction with P^+ will decrease on each step, so that the later steps do not have to be as fast as the early ones.

The RCs of bacteria and chloroplasts all have chains of electron acceptors as illustrated in Fig. 3. We shall discuss these in detail later. In each case that has been studied to date, the rates of both the forward electron steps and the back reactions seem to be greatest for the very early steps and decrease progressively on each step. In principle, a photosynthetic apparatus probably could operate equally well with a chain of electron donors that supply electrons rapidly to P^+ , moving the positive charge quickly away from A_1 . In practice, however, electron donors generally reduce P^+ on the time scale of 1–10 μsec , which is at least 10^3 times slower than the reactions between the early electron acceptors.

D. Experimental Approaches

Much of the experimental work on the primary photosynthetic reactions has been aimed at detecting and identifying the components of the electron acceptor chains. The most direct approach to the problem is to excite RCs with a short flash of light and to search for transient optical absorbance changes or ESR signals reflecting the reduction and reoxidation of a particular acceptor. Ideally, one should show that the acceptor is reduced and reoxidized rapidly enough to be consistent with a role in the electron transfer sequence. The reduction and reoxidation should occur with a quantum yield that is at least as high as that of the overall sequence.

The major difficulty in this approach is that one requires progressively faster and faster techniques in order to detect earlier and earlier acceptors. Optical techniques capable of resolving times less than

FIG. 3. Back reactions between P^+ and A^- can be prevented if there is a chain of secondary electron acceptors (A_2, A_3, \dots) that remove electrons rapidly from A_1 . The orbital overlap between A^- and P^+ decreases on each step.

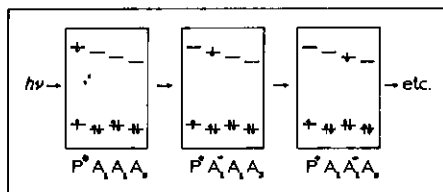

1 psec are available, but the assignments of very short-lived optical signals are frequently ambiguous and there are many possibilities for artifacts caused by the excitation flashes. ESR measurements are inherently three to four orders of magnitude slower.

A less direct, but very useful approach is to block electron transfer between two acceptors, A_i and A_j . This can be done by reducing A_j chemically before the excitation flash or by extracting A_j from the RCs. In some cases, electron transfer can be blocked by lowering the temperature or using a specific inhibitor. If electron transfer from A_i^- to A_j is blocked, the lifetime of $P^+ A_i^-$ may be long enough so that optical signals associated with A_i^- become relatively easy to detect. Even if A_i^- itself is still difficult to measure, it may be possible to detect back reactions between A_i^- and P^+ by measuring the decay kinetics of P^+ after a flash. The decay kinetics should become progressively faster as one blocks electron transfer closer and closer to A_1 . In addition to examining the decay of P^+ , one can look for the delayed fluorescence (delayed light emission; for a discussion of this phenomenon in green plants see Govindjee and Jursinic, 1979) that results from back reactions that regenerate P^* . Additional information can be obtained from side products such as triplet states that sometimes form by other types of back reactions.

The shortcoming of these indirect approaches is that a state that forms after electron transfer has been blocked is not necessarily an intermediate in the normal electron transfer pathway; it could be a side product. Eventually, one has to demonstrate the formation of the state in high quantum yield in unblocked RCs.

II. Photosynthetic Bacteria

A. General Scheme

Isolated RCs from photosynthetic bacteria generally contain four molecules of BChl, two of BPh, one or two quinones (Q_A or Q_I and Q_B or Q_{II}), one non-heme Fe, and three polypeptides. The structure of the bacterial RC has been discussed in detail by Okamura *et al.* (Chapter 5, this volume) and the orientations of the different chromophores in the complex has been discussed by Breton and Vermeglio (Chapter 4, this volume). As those chapters describe, two of the four BChls appear to interact with each other particularly strongly. It is this special pair (P870 or P) that undergoes photo-oxidation when the RC is excited with light. The lowest excited singlet state of the dimer (P^*) is about 1.38 eV above

the ground state. In the oxidized dimer (P^+), the spin of the unpaired electron is delocalized over the π systems of the two BChls.

Figure 4 shows an outline of the early electron carriers that remove electrons from P (Blankenship and Parson, 1979a). The excited dimer (P^*) transfers an electron to an acceptor (I) that involves both BChl and BPh. This step takes only a few picoseconds, but it probably consists of a sequence of several smaller steps. We shall discuss this in more detail later. The reduced acceptor (I^-) transfers an electron to Q_A ($\equiv Q_I$) in about 200 psec, and Q_A^- transfers an electron to Q_B ($\equiv Q_{II}$) in about 100 μ sec. P^+ usually is reduced by a *c*-type Cyt in 1–10 μ sec (not shown in Fig. 4). In some cases, the Cyt is tightly bound to the isolated RCs; in others, it is soluble and is lost during the purification of the RCs. Note that the rates of the electron transfer reactions decrease progressively on each step, as the problem of preventing back reactions becomes less and less serious.

B. Quinone Acceptors Q_A and Q_B

The transient reduction and reoxidation of Q_A and Q_B can be detected from optical absorbance changes and ESR signals, following the illumination of RCs (Clayton and Straley, 1970, 1972; Feher, 1971; Leigh and Dutton, 1972; Slooten, 1972; Dutton *et al.*, 1973; Feher *et al.*, 1974; Okamura *et al.*, 1975; Romijn and Amesz, 1976; Vermeglio, 1977; Vermeglio and Clayton, 1977; Wraight, 1977, 1978, 1979; Rutherford and Evans, 1979). Electron transfer between the two quinones can be blocked by lowering the temperature, by extracting Q_B , by certain inhibitors such as *o*-phenanthroline, or by treatments that remove the Fe from the RCs (Parson, 1978; Blankenship and Parson, 1979b). If the electron transfer reaction is blocked in any of these ways, $P^+Q_A^-$ decays by a back

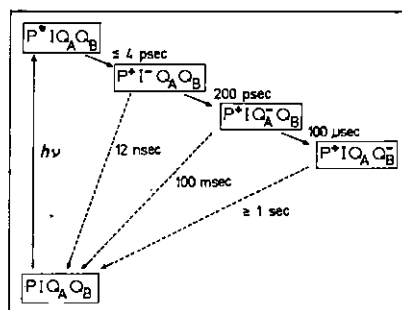

FIG. 4. Early electron transfer steps in photosynthetic bacteria. P, special dimer of BChls; I, BChl–Bph complex; Q_A ($\equiv Q_I$) and Q_B ($\equiv Q_{II}$), quinones. The dashed lines show back reactions, which usually are negligible unless the forward electron transfer reactions are blocked. This figure shows only processes that are reasonably well established. More speculative details of the initial reaction are given in Figs. 6 and 9.

reaction with a time constant of about 0.1 sec. This reaction increases in rate if one lowers the temperature (Parson, 1967; Clayton and Yau, 1972; Hsi and Bolton, 1974; Loach *et al.*, 1975). Whether the Fe atom actually plays a direct role in the reaction between the two quinones is not yet clear, because removal of the Fe requires treating RC preparations under conditions that cause the polypeptides of the RC to dissociate (Debus *et al.*, 1981). It has not yet been possible to restore the electron transfer reaction by adding Fe to the depleted preparations. Electron transfer from Q_A to Q_B and from Q_B to the Cyt_s is discussed in more detail by Cramer and Crofts, Chapter 9, this volume.

In intact chromatophores, the effective E_m of Q_A/Q_A^- is about -0.18 V (Prince and Dutton, 1976, 1978; Prince *et al.*, 1977; Rutherford *et al.*, 1979). The E_m of P^+/P in the ground state is about $+0.45$ V (Parson and Cogdell, 1975; Prince and Dutton, 1978). $P^+Q_A^-$ thus lies about 0.63 eV above PQ_A in free energy. For reasons that are not clear, the E_m of Q_A/Q_A^- in isolated RCs appears to be less negative (about -0.05 V) (Dutton *et al.*, 1973; Prince and Dutton, 1978), so that the free energy captured in $P^+Q_A^-$ is about 0.50 eV. One should bear in mind that thermodynamic parameters calculated from E_m values are subject to serious ambiguities and generally give only rough estimates of the physiologically meaningful parameters (Blankenship and Parson, 1979a).

C. The Initial (or Intermediate) Electron Acceptor Complex, I

The transient reduction of the earlier electron acceptor complex I also can be detected from optical absorbance changes following a short flash, provided that the flash is not much longer than about 10 psec (Dutton *et al.*, 1975; Kaufmann *et al.*, 1975, 1976; Rockley *et al.*, 1975; Netzel *et al.*, 1977; Holten *et al.*, 1978b, 1980; Peters *et al.*, 1978; Shuv-
alov *et al.*, 1978; Kryukov *et al.*, 1979; Akhmanov *et al.*, 1980; Schenck *et al.*, 1981a). To obtain such a flash, one generally starts with a mode-locked Nd : glass laser. The laser emits a train of short pulses at 1060 nm. A single pulse is selected from the train, amplified in a second laser and doubled in frequency to 530 nm. The 530-nm pulse can be used directly as the excitation flash or it first can be shifted to longer wavelengths by Raman shifting or other techniques. To generate a measuring or "probe" light pulse of other wavelengths, part of the 530-nm pulse or part of the original 1060-nm pulse is focused into a liquid such as CCl_4 . This generates a continuum of new wavelengths in a pulse that has about the same width as the original pulse. The probe pulse is delayed in time

with respect to the excitation pulse, and then passed through the sample, through a monochromator, and then to a detector. This allows one to measure the optical absorption spectrum of the sample, as a function of time after the excitation flash.

Figure 5A shows the optical absorbance changes that result from the excitation of *Rp. sphaeroides* RCs with a flash lasting about 8 psec (Schenck *et al.*, 1981a). The filled circles show measurements made at 3 nsec after the excitation, when the RCs are in the state $P^+IQ_A^-Q_B$ (see Fig. 5A). Most of the absorbance changes can be attributed to the photo-oxidation of P, because the reduction of Q_A causes only relatively small absorbance changes in the visible and near IR regions of the spectrum (see Okamura *et al.*, Chapter 5, and Breton and Vermeglio, Chapter 4, this volume). Oxidation of P causes bleaching of the RC's strong absorption band at 870 nm, and an apparent shift to shorter wavelengths of the band near 800 nm (a bleaching at 810 nm and an absorption increase at 790 nm). The absorbance changes around 800 nm probably mean that the electric field due to P^+ disturbs the absorption band of one or both of the other BChls of the RC, although P itself may also have some absorbance in this region (see Shuvalov and Parson, 1981b; Breton and Vermeglio, Chapter 4, this volume). Oxidation of P also causes partial bleaching of an absorption band at 600 nm. The bleaching at 600 nm was not measured in the experiment of Fig. 5 because the excitation flash was at 600 nm.

The open circles in Fig. 5A show measurements made at 20 psec after the excitation, when the RCs are still in the state $P^+I^-Q_A^-Q_B$. The

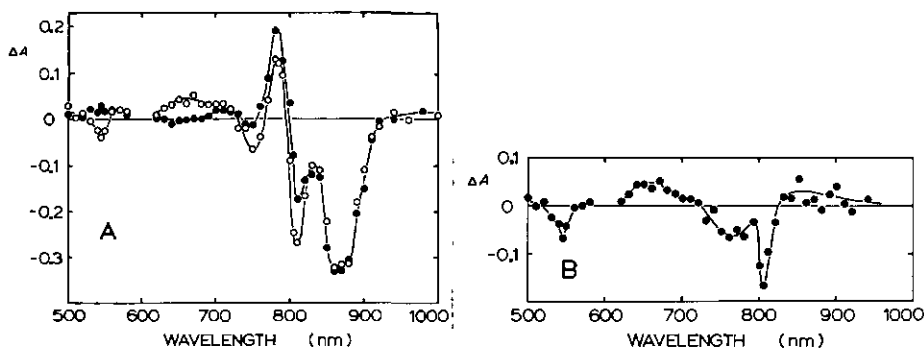

FIG. 5. Absorbance changes resulting from the excitation of *Rp. sphaeroides* R-26 RCs with nonsaturating, 8-psec flashes at 600 nm. (A) absorbance changes measured at 20 psec (○) and 3 nsec (●) after the excitation. (B) difference between the absorbance changes measured at 20 psec and 3 nsec. (From Schenck *et al.*, 1981a.)

difference between the absorbance changes measured at 20 psec and 3 nsec is plotted in Fig. 5B. This spectrum appears to reflect mainly the transient reduction of I to I^- . The difference spectrum includes bleaching at 545, 760, and 800 nm, and a broad absorbance increase near 670 nm. There also is a small bleaching at 600 nm that can be seen when the RCs are excited at 530 nm. The absorption bands at 545 and 760 nm are ascribed to the Bphs of the RC (see Okamura *et al.*, Chapter 5, and Breton and Vermeglio, Chapter 4, this volume), and the bleaching that occurs here suggests that I is one of the BPhs. Electrochemical reduction of BPh in solution causes very similar absorbance changes, including the formation of the broad absorption band near 670 nm (Fajer *et al.*, 1975; Davis *et al.*, 1979a). The absorption bands at 600 and 800 nm, on the other hand, are due to BChl. The changes that occur in these bands suggest that I is a complex involving both BPh and BChl.

Measurements like those shown in Fig. 5 have been made with RCs isolated from several other species of bacteria including *Rp. viridis* and *Rhodospirillum (Rs.) rubrum* (Holten *et al.*, 1978b; Shuvalov *et al.*, 1978). The difference spectra for the reduction of I are all qualitatively similar, but the absorption bands lie at longer wavelengths in *Rp. viridis*. This species contains BChl *b* rather than BChl *a*.

The quantum yield of I^- appears to be similar to that of P^+ (Parson *et al.*, 1975; Akhmanov *et al.*, 1980; Holten *et al.*, 1980). This indicates that the reduction of I is probably a step in the normal electron transfer sequence, and not simply a side reaction.

I^- decays with a time constant of 150–200 psec, presumably by transferring an electron to Q_A (Kaufmann *et al.*, 1975, 1976; Rockley *et al.*, 1975; Holten *et al.*, 1978b; Pellin *et al.*, 1978; Peters *et al.*, 1978; Schenck *et al.*, 1981a,b). It has not yet been possible to measure the reduction of Q_A directly with this speed but the decay of I^- can be blocked by reducing Q_A before the excitation flash, or by extracting Q_A from the RCs. Electron transfer from I^- to Q_A becomes somewhat slower if Q_B is reduced, perhaps because of the electrostatic effect of Q_B^- (Pellin *et al.*, 1978). The electron transfer kinetics are not very sensitive to temperature (Peters *et al.*, 1978); the reaction actually increases in speed with decreasing temperature down to about 20°K, and then begins to slow down (Parson *et al.*, 1978; Schenck *et al.*, 1981b).

If electron transfer to Q_A is blocked by the reduction or removal of Q_A , the P^+I^- radical pair decays by back reactions with a lifetime of about 12 nsec (Cogdell *et al.*, 1975; Parson *et al.*, 1975; Parson and Monger, 1977; Holten *et al.*, 1978b). The acceptor complex can be trapped in the reduced state for much longer time, if one illuminates

RCs with continuous light in the presence of a reduced Cyt after lowering the redox potential to reduce Q_A (Shuvalov and Klimov, 1976; Shuvalov *et al.*, 1976b; Tiede *et al.*, 1976a,b, van Grondelle *et al.*, 1976; Prince *et al.*, 1977; Troster *et al.*, 1977; Holten *et al.*, 1978b; Okamura *et al.*, 1979). Under these conditions, the 12 nsec lifetime of P^+I^- provides an opportunity for the Cyt to transfer an electron to P^+ . If this occurs, it leaves the RC in the state $PI^-Q_A^-$ or in $PI^-Q_A^{2-}$. Both of these states are relatively long-lived. $PI^-Q_A^-$ decays to PIQ_A^{2-} on the time scale of 0.01–5 sec; $PI^-Q_A^{2-}$ lives for many minutes (Okamura *et al.*, 1979). The optical absorbance changes that accompany the reduction of I in this manner are similar to those that have been obtained in the picosecond absorbance measurements.

Although I can be reduced photochemically, it may not be freely accessible to exogenous reductants, even in isolated RCs. Attempts to determine the E_m of I/I^- by redox titrations have given conflicting results that range from -0.40 to -0.62 V (Prince *et al.*, 1976, 1977; Shuvalov *et al.*, 1976b; Rutherford *et al.*, 1979). These E_m values would put the free energy of P^+I^- in the range 0.85–1.10 eV above that of the PI ground state.

An alternative way to study the thermodynamics of the electron transfer reaction is to measure the delayed fluorescence that results from the return of P^+I^- to P^*I . Delayed fluorescence of this sort can be seen when electron transfer from I^- to Q_A is blocked. The intensity of the delayed fluorescence should be a measure of the free energy difference between P^*I and P^+I^- , and the temperature dependence of the delayed fluorescence should be related to the energy difference between the two states. However, the delayed fluorescence can be quenched in ways that are not well understood and this makes interpretation of the measurements uncertain. With isolated RCs, the delayed fluorescence actually increases as one lowers the temperature, suggesting that some type of relaxation diminishes in importance with decreasing temperature (Clayton, 1977; Schenck *et al.*, 1982). Below 200°K, when the temperature-dependent relaxation appears to be insignificant, the delayed fluorescence decreases with decreasing temperature. The temperature dependence of the delayed fluorescence in this region suggests that the energy difference between P^* and P^+I^- is on the order of 0.03 eV (Schenck *et al.*, 1982). This would put the energy of P^+I^- about 1.35 eV above the ground state. Similar measurements in chromatophores and whole cells have given numbers ranging from 0.05 to 0.15 eV for the energy difference between P^* and P^+I^- (Shuvalov and Klimov, 1976; van Grondelle *et al.*, 1978; Godik and Borisov, 1979; Rademaker and Hoff, 1981). The anomalous temperature dependence of the delayed fluorescence at

temperatures above 200°K has not been seen in these more intact systems.

D. Electron Transfer between the Bacteriochlorophyll and Bacteriopheophytin of I

If I involves both BChl and Bph, does only one of the two undergo reduction or is the unpaired electron shared by both molecules? The answer to this is not yet completely clear. The ESR and ENDOR spectra of the I^- radical that are obtained by illuminating RCs continuously at low potentials can be interpreted most simply on the view that the unpaired electron is not shared, but is localized on the BPh (Fajer *et al.*, 1978; Davis *et al.*, 1979b; Okamura *et al.*, 1979). Thermodynamically, it should be easier to reduce the BPh than the BChl because the E_m for the one-electron reduction of BPh in organic solvents is about -0.55 V, whereas that of BChl is about -0.85 V (Fajer *et al.*, 1975). Reduction of the Bph in I could disrupt the electronic interactions between the two molecules, accounting for the changes in the absorption bands of the BChl. The ESR and ENDOR measurements, however, necessarily involve RCs in which P and Q_A are reduced, along with I. They may not provide an accurate picture of the electron distribution in the normal, transient state, $P^+I^-Q_A^-$. The electron distribution in I could depend strongly on the redox states of P and Q_A , because I must have significant orbital overlap with both of these components. In addition, the ESR and ENDOR spectra of I^- have been obtained at cryogenic temperatures. Studies of the optical absorption spectrum of RCs in the state $P^+I^-Q_A^-$ suggest that the charge on I^- is partly delocalized between the BChl and Bph (Shuvalov and Parson, 1981a). As one lowers the temperature, the charge appears to become localized more strongly on the Bph. The temperature dependence of the spectrum indicates that the state $[P^+BChl^-]Bph$ is probably about 0.025 eV above $[P^+BChlBph^-]$ in energy (Fig. 6).

Of the BChl and Bph that make up I, it seems likely to be the BChl that interacts more directly with P and serves as initial electron acceptor, and the Bph that serves to transfer the electron on to Q_A (Shuvalov *et al.*, 1978; Akhmanov *et al.*, 1980) (Fig. 6). This would be in accord with the fact that electron transfer from the BChl to the Bph is energetically downhill. One observation that supports this scheme is that the interaction between P and the BChl appears to be much stronger than that between P and the BPh (Shuvalov *et al.*, 1976b, 1977; Shuvalov and Asadov, 1979). The oxidation of P causes large changes in absorbance and circular dichroism (CD) in the 800-nm region where the BChl of I

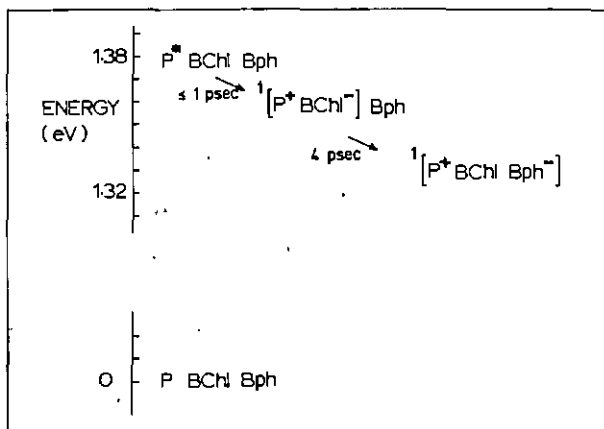

FIG. 6. Energies of radical pairs formed in the early reactions in bacterial RCs, and kinetics of the initial electron transfer processes. BChl and Bph are the components that are collectively called "I" in the text and in Fig. 4. The energy of $^1[P^+ BChl Bph^-]$ is based on the temperature dependence of the delayed fluorescence from RCs at low temperatures. That of $^1[P^+ BChl^-] Bph$ is based on the temperature dependence of the absorption spectrum of $P^+ I^-$. Both of these energies should be considered as only rough estimates. Note also that they are energies, and not free energies. All of the radical pairs shown here are singlet states. (The spins of the unpaired electrons on P^+ and A^- are antiparallel.) Triplet radical pairs are shown in Fig. 9.

absorbs, but no significant changes in the 760-nm region where the Bph absorbs. Reduction of the Bph causes absorbance and CD changes in the 800-nm region, but no significant changes in the 870-nm band due to P. As Breton and Vermeglio (Chapter 4, this volume) discuss, the interpretation of these absorbance and CD changes is still controversial. Additional evidence that P interacts more directly with the BChl than with the Bph comes from estimates of the energy differences between the singlet and triplet forms of the $[P^+ BChl^-] Bph$ and $[P^+ BChl Bph^-]$ radical pairs. This will be discussed later.

If an electron moves from P^* first to the BChl, and then on to the Bph, how long does the electron remain localized on the BChl before it moves on? For information on this point, one must make measurements at very early times after the excitation. The 20-psec delay used for the measurements in Fig. 5 is evidently too long because the equilibration of charge between the BChl and Bph has reached completion. Definitive measurements at shorter times require shorter excitation flashes than the ones that were used for Fig. 5. Figure 7 shows measurements of the absorbance changes that occur in the region around 545 nm, when *Rp. sphaeroides* RCs are excited at 610 nm with flashes lasting about 0.7 psec

(Holten *et al.*, 1980). Such flashes can be obtained from a dye laser that is pumped by an argon ion laser. The flash initially causes an absorbance increase over the entire region covered in the figure. The initial absorbance increase decays rapidly to give the bleaching at 545 nm that is associated with the reduction of Bph (cf. open circles in Fig. 5A). The time constant for this relaxation is approximately 4 psec.

The measurements shown in Fig. 7 indicate that the transfer of charge to the Bph occurs with a time constant of about 4 psec or faster. The actual transfer could be faster than it appears to be, because measurements made during and immediately after the flash can be complicated by absorbance changes due to short-lived excited states. For the same reason, the interpretation of the initial absorbance changes shown in Fig. 7 is not clear. They could represent the putative $[P^+BChl^-]Bph$ intermediate (Fig. 6), or simply an excited state of P or the other BChls of the RC.

Figure 8 shows a more extended spectrum of the very short-lived absorbance changes that precede the reduction of the Bph (Shuvalov *et al.*, 1978). These measurements were obtained by exciting *Rs. rubrum* RCs with a relatively long (25 psec) flash at 880 nm, but with the probe pulse timed so that most of measuring light passed through the sample before the excitation. The small overlap between the end of the probe pulse and the beginning of the excitation pulse provided a measurement of the absorbance changes during the first few psec after the excitation. Note that the absorption bands of Bph at 545 and 760 nm have not yet been bleached, in agreement with Fig. 7. There are, however, absorbance changes indicative of the oxidation of P. Superimposed on these is an additional bleaching at 800 nm, and an absorbance increase in the 650 nm region. These absorbance changes can be plausibly interpreted as reflecting the formation of $[P^+BChl^-]Bph$ (Shuvalov *et al.*, 1978).

In spite of the attractiveness of the idea that the reduction of the BChl precedes that of the Bph, there are several reservations concerning the

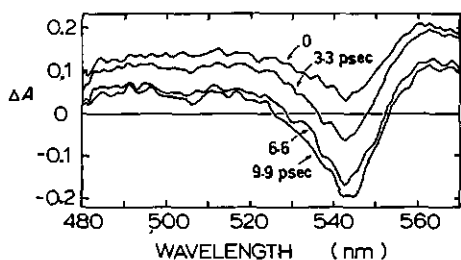

FIG. 7. Absorbance changes resulting from excitation of *Rp. sphaeroides* R-26 RCs with saturating 0.7-psec flashes at 610 nm. The numbers by the curves are the delays between the excitation and probe pulses; their uncertainty is about ± 1 psec. The development of the negative absorbance change at 545 nm is taken to reflect the localization of the electron on the Bph of I^- . (From Holten *et al.*, 1980.)

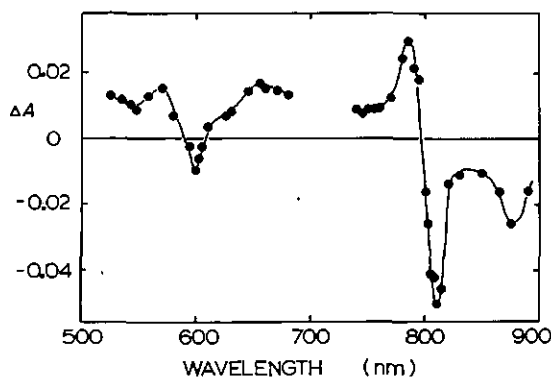

FIG. 8. Initial absorbance changes resulting from excitation of *Rs. rubrum* RCs with non-saturating 25-psec flashes at 880 nm. Most of the probe pulse passed through the sample before the excitation pulse, so that the measurements reflect mainly absorbance changes within the first few psec after the excitation. Complete oxidation of P in the sample would have given a ΔA of about 0.4 at 880 nm. (From Shuvalov *et al.*, 1978.)

evidence for the scheme. First, transient bleaching at 800 nm also can be seen when RCs are excited with an excessive number of photons (Kryukov *et al.*, 1979; Akhmanov *et al.*, 1980; Holten *et al.*, 1980). In this case, the bleaching seems likely to be due to an excited state that is not directly involved in the normal electron transfer sequence. Second, measurements in the 800-nm region have not yet been made with flashes that are short enough (and weak enough) to allow a meaningful comparison between the relaxation kinetics here and the bleaching kinetics at 545 nm. Work to resolve these ambiguities is underway.

E. Triplet States

A triplet state of P (state P^R) can be formed by the decay of the $P^+ I^-$ radical pair, when electron transfer from I^- to Q_A is blocked by the reduction or extraction of Q_A (Dutton *et al.*, 1972; Leigh and Dutton, 1974; Uphaus *et al.*, 1974; Wraight *et al.*, 1974; Cogdell *et al.*, 1975; Parson *et al.*, 1975; Thurnauer *et al.*, 1975; Hoff, 1976; Prince *et al.*, 1976; Hoff *et al.*, 1977; Parson and Monger, 1977; Gast and Hoff, 1978; van Grondelle *et al.*, 1978). State P^R is formed in a quantum yield of only about 10% at room temperature, but its quantum yield increases as one lowers the temperature (Parson *et al.*, 1975; van Grondelle *et al.*, 1978; Schenck *et al.*, 1982). As we shall discuss later, P^R is probably a mixture of a "pure" triplet excited state of P (3P) and a triplet charge transfer state, $^3[P^+ BChl^-]Bph$. These states are almost certainly not intermedi-

ates in the normal electron transfer sequence in unblocked RCs. Study of the triplet states has been useful, however, by providing information on the interactions between P^+ and I^- . In addition, studies of the effects of magnetic fields on the yield of P^R have provided strong evidence that the P^+I^- radical pair is created from an excited singlet state of P , without intersystem crossing to a triplet state.

If P^+I^- forms an excited singlet state, the spins of the unpaired electrons on P^+ and I^- must initially be antiparallel, and the radical pair must be in a singlet state (Figs. 1, 3, and 6). A back reaction that occurs under these conditions must either regenerate the excited singlet state (P^*) or return P to the ground state. A triplet state of P can form only if the spins on P^+ and I^- become parallel before the back reaction occurs. Such a change in the relationship between the spins is much easier in $[P^+ BChl Bph^-]$ than it would be if the two electrons were in the same molecule because the singlet and triplet states of the radical pair, $^1[P^+ BChl Bph^-]$ and $^3[P^+ BChl Bph^-]$, probably have very nearly the same energy. The difference between the energies of the singlet and triplet states depends on the orbital overlap between the unpaired electrons in P^+ and Bph^- , and this overlap must be much smaller than it would be if the two electrons were both in the same molecule. If $^1[P^+ BChl Bph^-]$ and $^3[P^+ BChl Bph^-]$ are nearly isoenergetic, they will be perturbed significantly by hyperfine magnetic interactions between electron and nuclear spins on the two molecules, by Zeeman interactions with magnetic fields, and by interactions with other electronic spins, such as that of Q_A^- (Haberkorn and Michel-Beyerle, 1977, 1979; Werner *et al.*, 1978; Bowman *et al.*, 1981). Because of these perturbations, the eigenstates of the radical pair are not pure singlet and triplet states, but quantum mechanical mixtures of these states. A radical pair that is born from a singlet state thus develops triplet character. The time scale for this development is probably on the order of 1–10 nsec. Back reactions that occur after the radical pair has developed triplet character can form P^R .

Magnetic fields can influence the rate of singlet–triplet interconversions in $P^+ BChl Bph^-$ because they separate the three sublevels of the triplet radical pair. In the presence of a field, one of the triplet sublevels (T_{+1}) moves to higher energy, and one (T_{-1}) to lower energy. Only the third sublevel (T_0) is unaffected by the field, and remains able to mix with the singlet state. One would expect, therefore, that weak magnetic fields would decrease the quantum yield of state P^R , and this is indeed observed (Blankenship *et al.*, 1977; Hoff *et al.*, 1977; Michel-Beyerle *et al.*, 1979; Rademaker *et al.*, 1979; Boxer *et al.*, 1982; Ogrodnik *et al.*, 1982; Roelofs *et al.*, 1982). In addition, the P^R that is formed in the

presence of a magnetic field is found to be almost exclusively in the T_0 sublevel (Dutton *et al.*, 1972; Leigh and Dutton, 1974; Uphaus *et al.*, 1974; Thurnauer *et al.*, 1975; Prince *et al.*, 1976). In the absence of a magnetic field, all three of the triplet sublevels of P^R are populated (Clarke *et al.*, 1976; Hoff, 1976; Hoff *et al.*, 1977; Parson and Monger, 1977; Gast and Hoff, 1978).

The decrease in the quantum yield of P^R can be seen with very weak fields. A field of about 40 G typically gives a half-maximal effect. The dependence of the effect on the field strength indicates that the splitting between $^1[P^+BChlBph^-]$ and $^3[P^+BChlBph^-]$ is only about 2×10^{-7} eV (Haberkorn and Michel-Beyerle, 1977; Werner *et al.*, 1978; Boxer *et al.*, 1982; Ogrodnik *et al.*, 1982; Roelofs *et al.*, 1982). If the splitting were much greater than this, one would expect weak fields to increase the yield of P^R because the field could raise the energy of the T_{+1} sublevel so that it matched that of the singlet state. No such increase in the yield is observed. [The yield does increase in the presence of extremely strong fields, which provide an additional mechanism for singlet-triplet mixing (Boxer *et al.*, 1982)]. Similar conclusions on the singlet-triplet splitting in P^+I^- have been drawn from measurements of the transfer of magnetic spin polarization between I^- and Q_A^- (Gast and Hoff, 1979). An upper limit of about 3.5×10^{-7} eV for the splitting has been obtained from measurements of the effects of microwave irradiation on the quantum yield of P^R (Bowman *et al.*, 1981). Microwaves with a frequency that matches the energy gap between two of the spin states in the radical pair can reverse the decrease in the P^R yield that is caused by a magnetic field.

The very small splitting between the singlet and triplet states of $P^+BChlBph^-$ means that the orbital overlap between the two radicals is extremely weak. This initially seems difficult to reconcile with the great speed of the electron transfer from P^* to I (Haberkorn *et al.*, 1979). If an electron can move rapidly back and forth between P^* and I^- , it should experience a strong exchange interaction with the lone electron in the HOMO of P . This interaction should give a large splitting between the singlet and triplet states of P^+I^- . The small splitting that is observed seems to mean that a relaxation of some sort follows the initial electron transfer from P^* to I . The relaxation could involve nuclear motion that increases the distance between P^+ and I^- , or it could be the movement of the electron from the $BChl$ to the Bph of I (Haberkorn *et al.*, 1979; Ogrodnik *et al.*, 1982). The magnetic field experiments probably reflect the situation after the electron has become localized mainly on the Bph .

The singlet-triplet splitting in the $[P^+BChl^-]Bph$ charge transfer state appears to be substantially greater than the splitting that the mag-

netic field experiments imply for $[P^+ BChl Bph^-]$. We have discussed the singlet radical pair $^1[P^+ BChl^-]Bph$ earlier and have indicated that it probably lies about 0.025 eV above $^1[P^+ BChl Bph^-]$ in energy (Fig. 6). The triplet charge transfer state $^3[P^+ BChl^-]Bph$ appears to make a small contribution to the absorption spectrum of RCs in state P^R (Shuvalov and Parson, 1981a,b). The temperature dependence of the spectrum suggests that $^3[P^+ BChl^-]Bph$ has an energy about 0.03 eV above that of the lowest localized triplet state of P (3P) (Fig. 9). The energy of 3P appears to be about 0.40 eV below that of P^* , or about 1.0 eV above the ground state, judging from the temperature dependence of delayed fluorescence from reaction centers in state P^R (Shuvalov and Parson, 1981). This means that the singlet-triplet splitting between $^1[P^+ BChl^-]Bph$ and $^3[P^+ BChl^-]Bph$ is about 0.35 eV (Fig. 9). This is enormously greater than the 10^{-7} eV between $^1[P^+ BChl Bph^-]$ and $^3[P^+ BChl Bph^-]$ (estimated from the effects of magnetic fields on the yield of P^R). Although additional work needs to be done to provide firmer information on the energy levels of 3P and the radical pairs, it seems clear that the orbital overlap between P and the BChl of I is extremely strong. This agrees well with the idea that the BChl acts as an intermediate electron carrier between P and the Bph.

To recapitulate the basic ideas underlying the schemes in Figs. 6 and 9, the singlet radical pairs form a cascade of states with closely spaced, decreasing energy levels. The triplet radical pairs are *not* intermediates

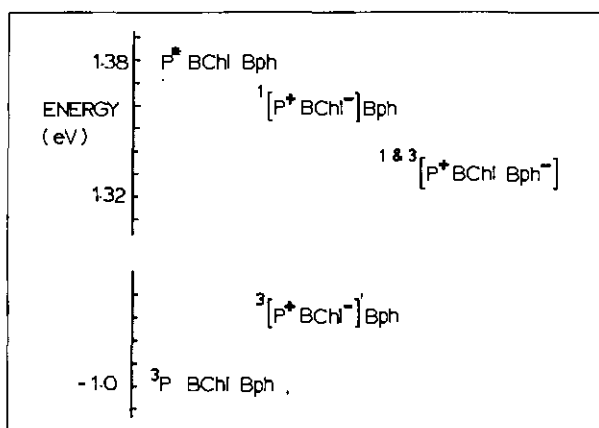

FIG. 9. Singlet and triplet radical pairs formed in bacterial RCs. The singlet radical pairs shown here are the same as those shown in Fig. 6. The energy of $^3[P^+ BChl^-]Bph$ is shown relative to that of 3P ; it is based on the temperature dependence of the absorption spectrum of P^R .

in the normal electron transfer sequence, but they provide information on the orbital overlap between P and the various electron acceptors. The orbital overlaps are reflected in the separations between the singlet and triplet states of the radical pairs. The overlap decreases rapidly as the electron moves to acceptors that are progressively farther away from P. As the orbital overlap decreases, the probability of back reactions decreases. This seems to account adequately for the remarkable efficiency of the photosynthetic apparatus.

F. Charge Transfer within the Reaction Center *Bacteriochlorophyll Dimer*

If we accept the idea that an electron first moves from P to BChl and then moves on to the Bph in about 4 psec, the initial separation of charge between P and the BChl would appear to take no more than about 1 psec. It could be even much faster than this. Nonetheless, there are indications that the initial electron transfer reaction may consist of several still smaller steps. The evidence on this point is indirect and is quite inconclusive, because states that decay in less than 1 psec are too fleeting for direct measurements with currently available technology. The approach that has been used here is to block electron transfer to I by reducing the Bph before the excitation. This can be done by illuminating RCs with continuous light in the presence of a reduced Cyt, as was described earlier. If RCs are excited with an 8 psec flash after I has been reduced in this manner, one sees a short-lived state of P that appears not to be simply an excited singlet state.

Figure 10 shows a spectrum of the absorbance changes that accompany the formation of the transient state in RCs from *Rp. sphaeroides* (Schenck *et al.*, 1981a). A qualitatively similar spectrum has been obtained with RCs from *Rp. viridis* (Holten *et al.*, 1978b), but the lifetimes of the transient states are different in the two species. The lifetime is about 20 psec in *Rp. viridis* and about 350 psec in *Rp. sphaeroides*. In both species, the absor-

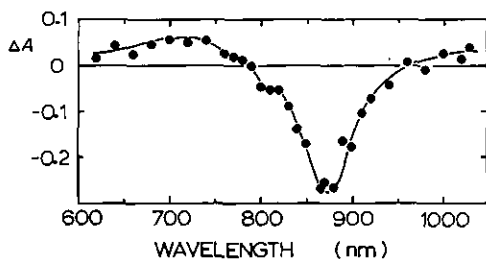

FIG. 10. Absorbance changes resulting from the excitation of *Rp. sphaeroides* R-26 RCs with non-saturating 7 psec flashes at 600 nm, after the reduction of I by continuous illumination at a low redox potential. (From Schenck *et al.*, 1981a.)

bance changes include bleaching of the absorption bands of P, but few if any changes in the bands due to the BChls or the Bphs. In Fig. 10, note that there is very little bleaching at 800 nm, where the BChl that is part of I absorbs (cf. Figs. 5 and 8). There also are no significant absorbance changes in the 1250–1350 nm region where there should be an absorbance increase if P undergoes oxidation (Netzel *et al.*, 1977). These observations may seem to argue against the idea that a BChl acts as an intermediate electron carrier between P and Bph. There certainly is no indication of the formation of the state $[P^+ BChl^- Bph^-]$, but the argument is not very compelling. If the BChl and Bph of I interact strongly, the prior reduction of the Bph could prevent electron transfer from P to the BChl.

What is the transient state that one sees after the reduction of I? The observations with RCs from *Rp. viridis* were interpreted initially as reflecting the excited singlet state, P^* (Holten *et al.*, 1978b). Work with *Rp. sphaeroides*, however, indicates that this interpretation is probably incorrect. If the transient state were the excited singlet state, the yield of fluorescence measured after the reduction of I should be several orders of magnitude greater than the fluorescence yield measured with I unreduced. (The lifetime of the transient state is 350 psec, whereas the lifetime of P^* with I unreduced must be less than 4 psec. The natural radiative lifetime of P^* cannot be much different under the two conditions, because the reduction of I causes only very minor changes in the absorption spectrum of P.) Contrary to this prediction, the reduction of I changes the fluorescence yield by less than a factor of 2 (Shuvalov and Klimov, 1976; Schenck *et al.*, 1981a). The total amount of luminescence actually decreases somewhat, presumably because new decay routes for P^* open up when the Bph is reduced.

The transient state thus appears not to be the excited singlet state P^* , but rather a metastable state that forms rapidly from the excited state. One possibility would be that the transient state is a triplet state of P that forms as a side product only because electron transfer to I is blocked. It is difficult to rule out this possibility at present, because the absorbance changes are not sufficiently diagnostic. The spectrum shown in Fig. 10 is actually very similar to the spectrum associated with the formation of the triplet state P^R (Parson *et al.*, 1975; Shuvalov and Parson, 1981b). The formation of a triplet state within a few psec and the decay within a few hundred psec would require an unusually fast mechanism for intersystem crossing, but this conceivably could result from magnetic interactions between P^* and I^- .

Another possibility is that the transient state is a charge transfer state in which an electron has moved from one of the two BChls of P to the other. This interpretation is particularly attractive because the charge

transfer state could be an intermediate in the transfer of an electron from P to I.

What would the energy level of the charge transfer state be relative to that of P*? We cannot answer this question because we do not have sufficient information about the structure of the RC. To a first approximation, the energy of the charge transfer state will be similar to that of the excited singlet state, because the formation of either state involves the promotion of an electron from a HOMO to a LUMO of BChl (see Fig. 1). As Breton and Vermeglio (Chapter 4, this volume) discuss, the excited singlet state that we have loosely called "P*" is probably the lower of two exciton states. The exciton states are formed by symmetric and antisymmetric combinations of the two excited states that would be obtained by exciting either one of the two BChls alone. The splitting between the exciton states depends on the change in dipolar interactions between the BChls, when one of the molecules is excited. The magnitude of the splitting is currently controversial, but it may be on the order of 0.13 eV (see Breton and Vermeglio, Chapter 4, this volume). The energy of the charge transfer states, on the other hand, probably depends more on the interactions of the BChls with other charged or dipolar groups nearby. If, for example, there is a negatively charged amino acid near one of the BChls (BChl_a), and a positively charged group near the other (BChl_b), the BChl_b⁻ BChl_a⁺ charge transfer state could be greatly favored over the BChl_a⁻ BChl_b⁺ state. The splitting between the two charge transfer states could easily be as great as 0.2 eV. Thus, it is quite possible that the lower charge transfer state lies below P* but still above the radical pair state that is formed when an electron moves from P to the BChl of I. This would put the charge transfer state in a position to serve as an intermediate in the electron transfer to I.

This discussion is necessarily speculative. If the lower charge transfer state is very close to the lower exciton state in energy, the two states could be mixed so extensively that they would not be detectable as discrete states. Additional work will be needed, in order to determine if the transient state actually is the charge transfer state, and whether or not it is an intermediate in the normal transfer of an electron from P to I.

III. Green Plants

A. General Scheme

The primary photochemical charge separation and electron transport reactions in green plant photosynthesis take place in two photosystems linked in series (see Govindjee and Govindjee, 1975). In each photosystem, the excited primary donor, P*, rapidly transfers an electron to

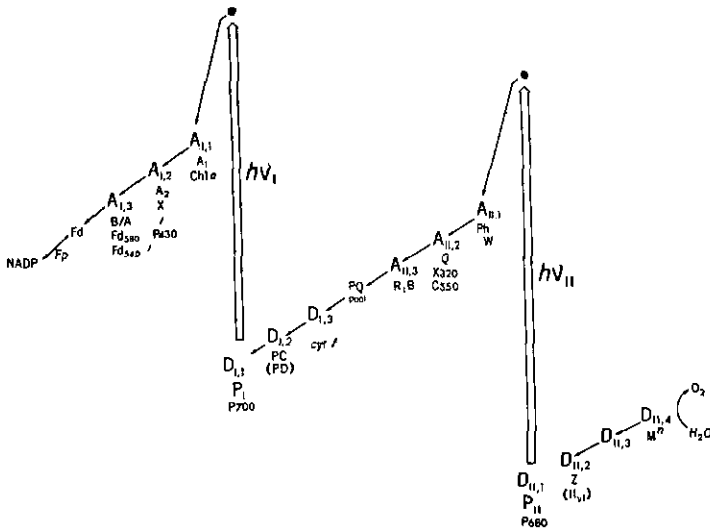

FIG. 11. The Z scheme for electron transport in green plant photosynthesis. General designations for the electron donors and acceptors are explained in the text. Some commonly used designations are also included in the scheme. A Rieske Fe-S center may function as $D_{1,3}$; M^n stands for the charge accumulator.

an acceptor and becomes oxidized to P^+ . The primary donor of photosystem I (PSI), P700, has been generally considered a Chl *a* dimer (Norris *et al.*, 1974). Recent ESR and ENDOR studies, however, show that both P700 and P680, the primary donors of PSII, could be monomeric Chl *a* (Davis *et al.*, 1979a; Wasielewski *et al.*, 1981).

In PSI, a very strong reductant and a moderate oxidant ($P700^+$) are formed, whereas in PSII, a very strong oxidant ($P680^+$) and a moderate reductant are formed. In PSII, water is the ultimate electron donor, and in PSI, ferredoxin (Fd) and NADP are the final electron acceptors. The moderate reductant of PSII and the oxidant of PSI link to complete the electron transport pathway.

The "Z scheme" encompassing the two photosystems is presented in Fig. 11. Since we will deal extensively here with the "early" electron acceptors as well as the early secondary donor(s), we use A (acceptor) and D (donor) as generalized descriptions for these species. Subscripts I and II indicate the photosystem to which each component belongs, and subscripts 1, 2, . . . for the position of the component in the electron transport sequence. P700 ($D_{1,1}$ *) and P680 ($D_{11,1}$) represent the primary

*The symbols $D_{1,1}$ and $D_{11,1}$ for P700 and P680 are used in this volume only in this chapter by Parson and Ke, and Chapter 5 by Okamura *et al.*—editor.

donors of PSI and PSII, respectively. The commonly used abbreviations for the electron carriers are also included in Fig. 11. Currently known electron transport rates under physiological conditions and reaction times in detergent-fractionated subchloroplast fragments or those occurring in chloroplasts under perturbed conditions (higher or lower pH, heating, chemical or inhibitor treatment, low temperature), are discussed in the text.

Chronologically, knowledge of the early electron acceptors was unveiled in the order from the more remote to the primary electron donor. This is because of the relatively long lifetimes of the reduced forms of the more remote species, which render them easier to detect. As discussed earlier, one effective way to maintain a high photosynthetic efficiency is to have more than one acceptor molecule participate in transferring the electron away from P^+ within a very short time span after the initial charge separation. Advances of our knowledge of these early acceptors have been facilitated by various experimental manipulations: (a) use of subchloroplast fragments enriched in reaction center components to obtain strong signals of interest; (b) sufficient instrument time response to resolve fast events; (c) use of redox conditions to block certain segments of the electron transport chain selectively; and (d) application of cryogenic temperatures to slow reaction rates or to alter reaction pathways.

The strong reductant of PSI and the strong oxidant of PSII are naturally of great interest, as they are respectively the sites where the reducing power for $NADP^+$ reduction and oxidizing power for water oxidation are initially formed from light-energy conversion. Properties of these two components are probably least known among the electron carriers, but they also constitute one of the more intensively studied subjects.

B. Chloroplast Photosystem I

1. THE PRIMARY ELECTRON DONOR P700

Since its discovery by Kok in 1956, the primary electron donor of PSI, P700, has been extensively studied and documented (Ke, 1973, 1978; Sauer, 1975; Hoch, 1977). Its dimeric nature has been suggested by ESR and ENDOR spectroscopy (Katz and Norris, 1973) and supported by circular dichroism studies (Phillipson *et al.*, 1972). However, recent work by Wasielewski *et al.* (1981) using deuterated, highly ^{13}C -enriched alga showed that $P700^+$ consists of a single oxidized Chl *a*-type macrocycle. Interpretation of the origin of the difference spectrum ($P700^+ - P700$)

has been made by many workers in terms of exciton interaction and energy level splitting (van Gorkom *et al.*, 1974; Schaffernicht and Junge, 1981). Much useful information on the disposition of P700 in the thylakoid membrane has been obtained from linear dichroism (e.g., Breton *et al.*, 1975) and photoselection studies (Junge, 1976; Schaffernicht and Junge, 1981) (see Breton and Vermeglio, Chapter 4, this volume).

The differential molar extinction coefficient of P700 in digitonin-fractionated subchloroplast particles is $64,000 M^{-1}\cdot\text{cm}^{-1}$ (Hiyama and Ke, 1972a). A similar value was obtained for intact chloroplasts by measuring the quantitative relationship between the number of electrons generated by light in PSII (measured by flash yield of oxygen evolution) and those transferred to oxidized P700 (Haehnel, 1976).

The E_m of P700⁺/P700 was first determined by Kok (1961) on chloroplasts enriched in P700 after acetone extraction, and a value of +0.43 V (versus standard hydrogen electrode) was obtained. Subsequent measurements (Rumberg, 1964; Yamamoto and Vernon, 1969; Knaff and Malkin, 1973; Ke *et al.*, 1975; Shuvalov *et al.*, 1976a; Evans *et al.*, 1977; Setif and Mathis, 1980) yielded values ranging from +0.37 to +0.53 V with the majority of cases having the value of about +0.48 V. Most of the variations in previously reported values are probably caused by changes in the environment of P700 in the different types of particles used.

The following sections will deal with the early (both primary and secondary) electron carriers. They will be discussed in the sequence of their participation in the photochemically initiated electron transport in the RC rather than in the usual chronological order of research development.

2. DIRECT DETECTION OF P⁺·A_{I,1}⁻, P⁺·A_{I,2}⁻, AND P⁺·A_{I,3}⁻; KINETICS OF ELECTRON TRANSFER FROM P* TO A_{I,1}, A_{I,2}

a. A_{I,1}. The charge separation between P700 and A_{I,1} was first "isolated" photochemically and spectroscopically using PSI fragments in which all acceptors except A_{I,1} were either (a) chemically reduced at a highly reducing potential (Sauer *et al.*, 1978) ; or (b) maintained in the reduced state by background illumination at a moderately reducing potential (-0.62 V) (Shuvalov *et al.*, 1979a). Figure 12A shows the difference spectrum constructed from the initial absorption changes induced by 300 nsec, 710 nm dye-laser pulses in Triton-fractionated TSF-I fragments under condition (b) at 5°K. This absorption change decays with a t_d of 1.3 msec at 5°K. Assuming that the difference spectrum plotted from the 1.3 msec absorption changes represents a composite of (P700⁺ - P700) and (A_{I,1}⁻ - A_{I,1}), and further assuming that the former

FIG. 12. (A) Spectrum of light-induced absorbance changes with lifetime of 1.3 msec in TSF-I particles poised at -0.62 V and at 5°K . This spectrum probably represents the changes: $(\text{P700}^+ - \text{P700}) + (\text{A}_{1,1}^- - \text{A}_{1,1})$. The inset shows kinetics of absorbance changes at 696 nm and 480 nm induced by 710 -nm laser excitation. (B) Solid curve, result of subtraction of the $(\text{P700}^+ - \text{P700})$ spectrum from the spectrum in (A), assuming equal extinction coefficient for P700 and $\text{A}_{1,1}$ at 700 nm. Dashed curve, spectrum of $(\text{ChL}^- - \text{Chl})$ in solution (taken from Fujita *et al.*, 1978). Wavelength scale for the latter spectrum is shifted to the red by ~ 25 nm. It may also be possible that the absorbance changes shown in (A) are partly due to a triplet state of P700 (Setif *et al.*, 1981). (From Shuvalov *et al.*, 1979a.)

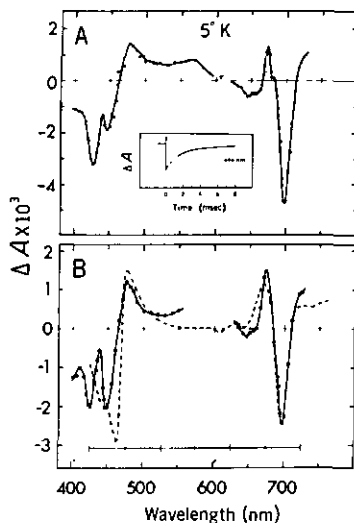

change contributes approximately 50% of the total change in the far-red band, one may obtain $(\text{A}_{1,1}^- - \text{A}_{1,1})$ (shown in Fig. 12B) by subtracting from the total spectrum in Fig. 12A the $(\text{P700}^+ - \text{P700})$ spectrum separately obtained at room temperature. The spectrum in Fig. 12B differs from the $(\text{P700}^+ - \text{P700})$ spectrum by additional bleaching at 445 nm and a development of the 480 - and 672 -nm bands. Instead of an absorbance increase near 400 nm usually observed in the P700^+ difference spectrum, there is an absorbance decrease.

The difference spectrum derived in this manner appears very similar to that for the formation of Chl *a* anion radical (Fujita *et al.*, 1978), particularly the development of two intense bands, one at wavelength slightly longer than the Soret band and the other at wavelength shorter than the main red band of Chl *a*. We suggested that the development of the bands near 480 and 670 nm in the $(\text{A}_{1,1}^- - \text{A}_{1,1})$ spectrum possibly reflects the formation of a Chl anion radical in PSI fragments. The possibility that Chl *a* functions as $\text{A}_{1,1}$ has previously been suggested by Zakharova and Chibisov (1977) and by Friesner *et al.* (1979).

In Fig. 12B, the difference spectrum for the formation of Chl *a* anion radical is retraced by the dashed curve, and shifted toward longer wavelength by 23 nm to coincide with the $(\text{A}_{1,1}^- - \text{A}_{1,1})$ difference spectrum. The red shift of the $(\text{A}_{1,1}^- - \text{A}_{1,1})$ spectrum from the known monomer spectrum was tentatively interpreted by assuming that the Chl *a* acceptors in PSI may be dimeric. Interestingly, the bleaching observed at 420 , 450 , and 700 nm coincide with the absorption bands of Chl *a* dimer in

solution (Fong *et al.*, 1976). However, the most recent ENDOR experiments indicate that $A_{I,1}^-$ is most likely a monomeric Chl *a* anion radical (Fajer *et al.*, 1980).

As discussed later, the difference spectrum ($A_{I,1}^- - A_{I,1}$) may also be isolated strictly from absorption changes with characteristically very rapid decay times in subchloroplast fragments at 20°C.

When chloroplasts are heated at 60°–65°C for 5 min, the absorption changes of P430, the spectral species presumed to be an early acceptor in PSI, are eliminated (Shuvalov, 1976); however, absorption changes attributable to P700 photo-oxidation persist. It was suggested that heating probably inactivated P430, whereas P700 was not affected and could still transfer its electron to an acceptor located closer to it or to an unknown alternate acceptor. PSI fragments isolated from chloroplasts after treatment with SDS apparently also contain only the acceptor $A_{I,1}$ (Mathis *et al.*, 1978). The difference spectrum constructed from absorption changes in both of these kinds of particles presumably represents the changes in both P700 and $A_{I,1}$ [(P700⁺ - P700) + ($A_{I,1}^- - A_{I,1}$)] (Baltimore and Malkin, 1980a,b).

In Triton subchloroplasts or chloroplasts that were poised only with ascorbate and DCIP so that the bound Fe-S proteins could not have been reduced beforehand, decay kinetics of P700⁺ with $t_{1/2}$ of 0.5–1.0 msec could be observed at 5°K (Sauer *et al.*, 1979; Conjeaud and Mathis, 1980). In spinach chloroplasts, rapid decay phases with $t_{1/2}$ of 120 μsec and 1.5 msec began to appear at 95°K, and the fast phase became more dominant with decreasing temperature (e.g., 91% with $t_{1/2}$ of 122 μsec at 8°K). These observations suggest that at low temperatures the electrons released by P700 can move to the near-neighbor acceptors, but not to the more remote ones. However, previous observations (Ke *et al.*, 1973a, 1977, 1979; Demeter and Ke, 1977) in subchloroplasts poised under similar conditions showed that a major fraction of the electrons released from P700 after photoexcitation apparently became trapped by the more remote acceptor(s), the Fe-S centers.

b. $A_{I,2}$. When the two bound Fe-S proteins in TSF-I particles are chemically reduced at -0.62 V, the light-induced absorbance changes at 5°K also display a 130 msec component in addition to the 1.3 msec component associated with $A_{I,1}^-$ formation and decay (Shuvalov *et al.*, 1979a) (Fig. 13A inset). The light-minus-dark difference spectrum of the 130 msec component (Fig. 13A) is characterized by bleaching near 430, 455, 655, 677, and 700 nm, development of broad bands between 470 and 570 nm and beyond 725 nm, and development of narrow bands at 445, 672, and 688 nm. This spectrum has been interpreted as due in

FIG. 13. (Top) spectrum of light-induced absorbance changes with lifetime of 130 msec in TSF-I fragments poised at -0.62 V and at 5°K . This difference spectrum represents the changes: $(P700^+ - P700) + (A_{1,2}^- - A_{1,2})$. The inset shows kinetics of absorbance changes at 430 nm induced by 710 -nm dye laser excitation. (Bottom) Light-minus-dark difference absorption spectrum of TSF-I fragments poised at -0.62 V and at 4°C . This difference spectrum represents the change $(A_{1,2}^- - A_{1,2})$. The absorption changes were measured in a dual-wavelength spectrophotometer, using continuous background illumination. (From Shuvalov *et al.*, 1979a.)

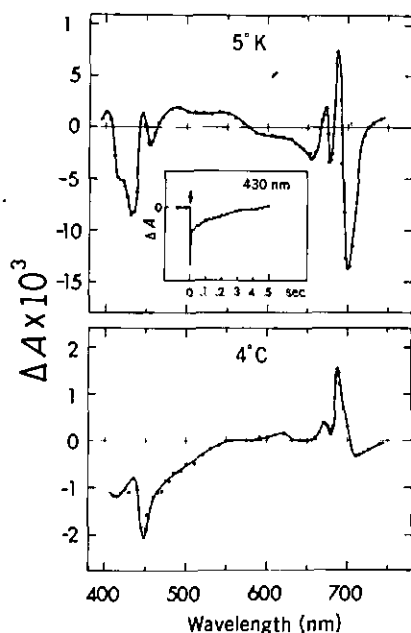

part to $P700^+$ formation plus a blue shift of a narrow band near 450 nm and development of bands near 670 and 690 nm. The latter absorption changes were suggested to be due to the reduction of the acceptor $A_{1,2}$.

This possibility was verified by measuring the absorption changes induced by continuous illumination at 4°C in TSF-I particles poised at -0.62 V. Under these conditions, the rate of electron donation to $P700^+$ from the low-potential mediators in the medium becomes competitive with the rate of recombination between $P700^+$ and $A_{1,2}^-$ formed in the light, thus resulting in an accumulation of $A_{1,2}^-$ (Shuvalov *et al.*, 1979a). As shown by the spectrum of the light-induced reversible absorption changes in Fig. 13B, no bleaching is observed at 700 nm, confirming that $P700$ is maintained in its reduced state. The spectrum is further characterized by a broad bleaching in the 400 – 550 nm region and a bleaching of a narrow band near 710 nm, a blue shift of the 442 -nm band, and a development of narrow bands at 672 and 688 nm. The broad bleaching in the blue-green region is indicative of the reduction of an Fe-S center, while the absorbance changes in the 450 nm and 670 – 720 nm regions are probably electrochromic shifts in the absorption spectrum of some Chl molecules, induced by the electric field of the reduced acceptor $A_{1,2}^-$.

An alternate means of observing $A_{1,2}$ photoreduction and decay in

PSI particles was to accumulate $A_{1,3}$ photochemically with preilluminating flashes in the presence of a reduced mediator that is known to react with $P700^+$ much more rapidly than the time needed (30–50 msec) for the recombination between $P700^+$ and $P430^-$ (see next section). Indeed it took two successive preilluminating flashes before an absorption change with decay characteristics of $A_{1,2}$ could be seen (Sauer *et al.*, 1978). This suggests that there are two equivalents of electron acceptors located beyond $A_{1,2}$. The obvious candidates for the equivalents are the two bound Fe–S centers (see next section).

c. $A_{1,3}$. A spectral species, P430, detected by flash-kinetic spectroscopy (Hiyama and Ke, 1971a), and a “bound ferredoxin,” detected by ESR spectroscopy (Malkin and Bearden, 1971), were separately proposed to be the “primary” electron acceptor of PSI. These coincidental developments subsequently led to a correlation of the two components and to the realization that P430 probably follows $A_{1,2}$ in the electron transfer sequence. The difference spectrum of absorption changes associated with charge recombination in unreduced TSF-I particles would be viewed as consisting of the changes $[(P700^+ - P700) + (P430^- - P430)]$ or $[(P700^+ - P700) + (A_{1,3}^- - A_{1,3})]$. In fact, by providing appropriate secondary donors or acceptors to the PSI reaction center, decay of $P700^+$ and $P430^-$ could be made to occur at different rates, and separate difference spectra for the changes $(P700^+ - P700)$ and $(P430^- - P430)$ could readily be constructed (Fig. 14).

The simultaneous but separate findings of P430 by optical spectroscopy and chloroplast-bound Fe–S proteins by ESR spectroscopy, and the assignments of an identical functional role to the two components as the “primary” electron acceptor of PSI, led to an intensive inquiry into the relationship between the two components. All correlations made thus far are indirect and some of them circumstantial. The major difficulty in this situation is an experimental one: ESR detection of the Fe–S proteins can only be made at a temperature near 10°K, whereas the optical kinetics of P430 were measured at room temperature. Unlike the species $A_{1,1}$ and $A_{1,2}$, which can react reversibly even down to 5°K, the two bound Fe–S centers (ISC) (B and A), once photoreduced at cryogenic temperatures, are either irreversibly trapped or recombine with $P700^+$ extremely slowly (see Section III,B,3). The time resolution of currently available rapid freeze-quenching techniques is not yet adequate for such correlations.

The light-minus-dark difference spectrum initially measured for P430 in the visible and UV regions (Hiyama and Ke, 1971b; Ke, 1972) already suggested an Fe–S protein to be a possible candidate. The first

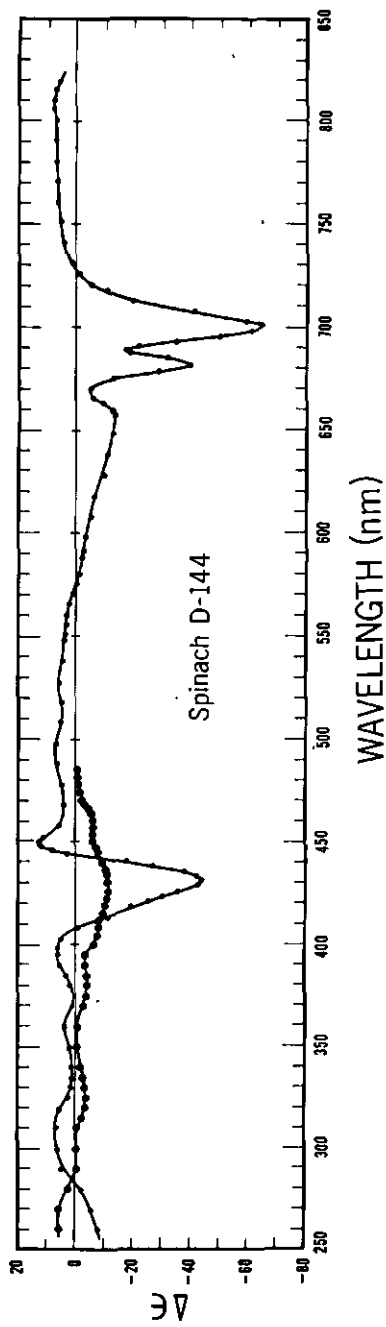

FIG. 14. Light-minus-dark difference spectra for (P700+ - P700) and (P430 - P430) in digitonin-fractionated PSI particles. (From Ke, 1973.)

attempt at a correlation was based on the observation that preillumination of TSF-I particles in the presence of an auto-oxidizable secondary acceptor such as methyl viologen led to an accumulation of $P700^+$ and thus prevented transient $P700$ absorption changes upon subsequent flash illumination. The same sample rapidly frozen to 5°K also did not show an ESR signal of reduced Fe-S proteins (Ke and Beinert, 1973).

Simultaneous measurements of the fractions of decay of $P700^+$ and ISC-A initially formed in a subchloroplast sample at 10°K and subsequently exposed to elevated temperatures for various periods of time demonstrated that ISC-A was the reaction partner of $P700^+$ in the recombination reaction (Ke *et al.*, 1974; also cf. Bearden and Malkin, 1974; Visser *et al.*, 1974).

Additional indirect evidence correlating P430 with an Fe-S protein was provided by the redox titration of the chloroplast-bound Fe-S proteins on the one hand (Ke *et al.*, 1973a), and the titration of the amplitude of light-induced $P700$ absorption changes (Ke, 1975; Lozier and Butler, 1974) on the other. The midpoint potential of the photometric titration curves agreed closely with that of the first-stage ESR titration of the bound Fe-S proteins of PSI. The fact that illumination of dark-adapted subchloroplast particles at low temperatures led to reduction of only the less negative of the Fe-S proteins also suggests that ISC-A is probably the same as P430.

As it is now known that possibly one more Fe-S ($A_{I,2}$) may be present between the earliest acceptor ($A_{I,1}$) and the bound ICSs-A,B, an inquiry into the question of the identity of P430 is being renewed. This question remains an important one, as a large body of spectral studies have established that P430 is the direct electron source for all the secondary electron acceptors tested so far (Hiyama and Ke, 1971a,b) including ferredoxin (Hiyama and Ke, 1972b; Bouges-Bocquet, 1980). Also it has now been suggested that P430 may correspond to $A_{I,2}$ (Hiyama and Fork, 1980). The optical difference spectrum measured for ($A_{I,2}^- - A_{I,2}$) (Shuvalov *et al.*, 1979a) is indeed consistent with this notion. However, definitive kinetic correlation is needed.

d. Picosecond Spectroscopy Involving $A_{I,1}$ and $A_{I,2}$ Forward Reactions. Using Q-switched ruby laser pulses of 20-nsec duration, the risetimes for the formation of $P700^+$ (and also $P430^-$) were determined to be ≤ 100 nsec (Ke, 1972) (as limited by the bandwidth of the signal processor) and ≤ 20 nsec for $P700^+$ (Witt and Wolff, 1970). Further attempts in applying picosecond excitation pulses for examining the charge separation and subsequent electron transfer among the early acceptors in PSI have yielded a risetime of ≤ 30 –50 psec for $P700^+$

formation (Fenton *et al.*, 1979; Shuvalov *et al.*, 1979b,c; Kamogawa *et al.*, 1981). Using mode-locked ruby laser pulses at 694.3 nm for excitation as well as measuring, it was determined that $A_{I,1}^-$ decays with a $t_{1/2}$ of ~ 200 psec (Fig. 15A). This presumably is the time for electron transfer from $A_{I,1}^-$ to $A_{I,2}$. The electron transfer time from $A_{I,1}^-$ to $A_{I,2}$ at cryogenic temperatures has not yet been measured. From preliminary ESR kinetic

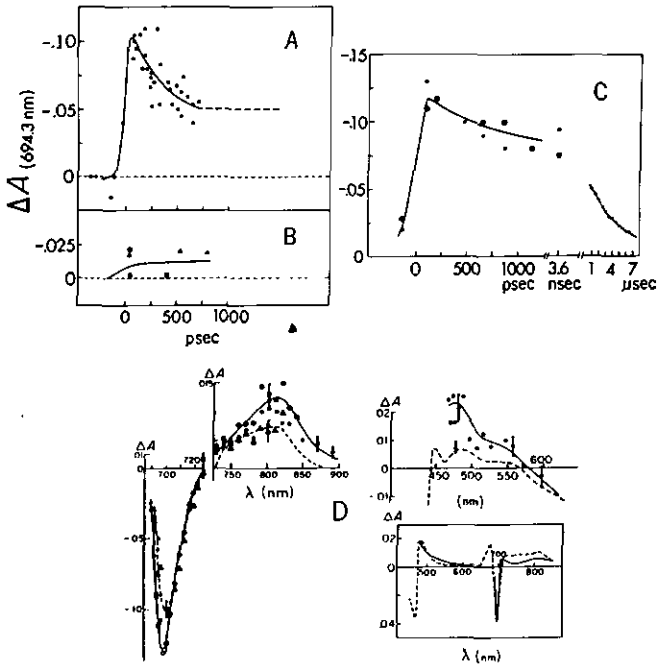

FIG. 15. (A) Kinetics of absorbance changes at 694.3 nm in TSF-I fragments poised at about +0.2 V and induced by single 50–60 psec 694.3-nm pulses at 20°C. (B) Same conditions as in (A), except sample contained additional methyl viologen and under background illumination to cause P700⁺ accumulation. (C) Kinetics of absorbance changes at 694.3 nm in TSF-I fragments poised at ~ 0.62 V and under background illumination to cause $A_{I,2}^-$ accumulation. 50–60 psec pulses were used for the nano- and subnanosecond time domain, and 300-nsec 710-nm dye laser pulses were used for microsecond measurements. (D) Spectra of light-induced absorbance changes measured 150 psec (○ and ●) and 800 psec (Δ and ▲) after excitation with 708-nm (● and ▲) or 689-nm (○ and Δ) psec pulses in the red (left) and shorter wavelength (right) regions in TSF-I fragments poised at about +0.2 V. The dashed curves show the difference spectrum of P700 measured in the same sample by continuous illumination. The inset (bottom, right) shows the difference spectrum between the 150-psec and the 800-psec spectra; the dashed curve is the difference spectrum for the formation of Chl *a* anion radical (Fujita *et al.*, 1978), shifted toward the red to coincide with the measured difference spectrum. (A, B, and C from Shuvalov *et al.*, 1979b; C and D from Shuvalov *et al.*, 1979c.)

measurements (see later), this time would be $< 100 \mu\text{sec}$ (Shuvalov *et al.*, 1979a).

When P700 is maintained in the oxidized state, the absorption change induced by a psec pulse is decreased 10-fold (Fig. 15B). Figure 15D shows the difference spectrum constructed from the 200 psec decay signals obtained by using a mode-locked Nd-YAG laser (Shuvalov *et al.*, 1980). This difference spectrum is in good agreement with that obtained for $(A_{I,1}^- - A_{I,1})$ by μsec spectroscopy (cf. Fig. 12B) and also with the *in vitro* spectrum of the Chl *a* anion radical (Fujita *et al.*, 1978).

The electron transfer time from $A_{I,2}^-$ to $A_{I,3}$ has not yet been measured. If the assumption is valid that P430 is the same as one of the bound Fe-S center(s), the reduction time of $A_{I,3}$ or the electron transfer time from $A_{I,2}^-$ to $A_{I,3}$ would be $\leq 100 \text{ nsec}$ (Ke, 1972).

3. KINETICS OF BACK-REACTIONS BETWEEN P^+ AND $A_{I,1}^-$, $A_{I,2}^-$, AND $A_{I,3}^-$

When the two bound Fe-S centers are chemically reduced, photoreduced $A_{I,1}^-$ and $A_{I,2}^-$ recombine with $P700^+$ at different rates. Recombination between $P700^+$ and $A_{I,1}^-$ occurs at room temperature with lifetimes of 10 nsec and 3 μsec (Fig. 15C). The 10 nsec absorption change component probably reflects two simultaneous processes of the ion radical pair $P700^+ \cdot A_{I,1}^-$, one being charge recombination and the other conversion to a state with some triplet character. The triplet state has a decay time of 3 μsec at room temperature and 1.3 msec at 5°K (Shuvalov *et al.*, 1979a; also cf. Shuvalov, 1976; Frank *et al.*, 1979). $A_{I,2}^-$ recombines with $P700^+$ in 250 μsec at room temperature (Sauer *et al.*, 1978) and 130 msec at 5°K (Shuvalov *et al.*, 1979a).

Under more reducing conditions when $A_{I,2}$ is reduced in addition to the other two bound Fe-S centers, the light-induced absorption change decays much more rapidly. This decay time was measured to be 3 μsec at room temperature (Sauer *et al.*, 1978; Shuvalov *et al.*, 1979a) and 0.55 msec (Sauer *et al.*, 1978) or 1.3 msec (Shuvalov *et al.*, 1979a) at 5°K. In subchloroplasts under these reducing conditions or in an SDS-fractionated PSI particle, in which presumably only P700 and $A_{I,1}$ still remain photochemically active, the rate of the recombination between $P700^+$ and $A_{I,1}^-$ apparently decreases with decreasing temperature from 293°K ($t_1 = 3 \mu\text{sec}$) to 70°K, then remains practically constant in the 70°–5°K region (Mathis *et al.*, 1978; Shuvalov *et al.*, 1979b). However, some of the absorbance changes seen in these systems may be due to triplet states (Setif *et al.*, 1981). In a frozen sample of untreated PSI subchloroplasts, i.e., when all acceptors are present in the oxidized state and ready to receive and transfer electrons released by P700, a single

flash will reduce predominantly ISC-A, the Fe-S center, with the least negative E_m (-0.53 V) and with g values of 2.05, 1.94, and 1.86. At very low temperatures, a small fraction of the P700 absorption change is reversible, indicating that some electrons travel only as far as $A_{1,1}$ and/or $A_{1,2}$.

The electrons trapped at ISC-A return to $P700^+$ relatively slowly. Depending on the temperature, two qualitatively different types of kinetics were observed. In the 294° – 240° K region, Arrhenius-type exponential kinetics were observed with the rate constant $k = 1 \times 10^{10} \cdot \exp(-16,000/RT)$ sec^{-1} . Below 220° K, logarithmic ($< 80^\circ$ K) or near-logarithmic kinetics (220° – 80° K) were observed (Ke *et al.*, 1979).

The switchover of the overall rate of $P700^+$ decay near 220° K was attributed to a phase transition in the sample. The change in the behavior of recombination kinetics at the moment of the phase transition may arise from either a change in the structural arrangements or conformational states in the reactants. The fact that the charge recombination reaction is observed at very low temperatures, when diffusion of $P700^+$ and the reduced acceptor molecules in chloroplasts seems impossible, indicates that the recombination takes place by way of electron tunneling.

The logarithmic kinetics for $P700^+$ decay below 220° K has been explained by assuming a broad rectangular distribution among the various ($P700^+ \dots A_{1,3}^-$) pairs over the value of some distribution parameter, of which the rate constant k is an exponential function (Zamaraev and Khairutdinov, 1974). The distribution of the values of the rate constant may be accounted for by different environments around or different mutual orientations of the reacting species $P700^+$ and $A_{1,3}^-$, or by different distances between them in the various reacting pairs. A distribution function reconstructed from the experimentally measured $P700^+$ decay in the temperature range of 160° – 80° K showed a 4.5 order-of-magnitude variation in the rate constant. If the distribution over k is assumed to be solely due to a distribution of the reacting pairs over the interspecies distance, the kinetic formulations would yield a distribution of 5 Å. The tunneling distance for the majority of the ($P700^+ \dots A_{1,3}^-$) pairs has been estimated from the ESR linewidth of $P700^+$ to exceed 13.2 Å. (For a detailed treatment of the electron tunneling process, see DeVault, 1980.)

4. ESR SPECTROSCOPY

The difference spectra for ($A_{1,1}^- - A_{1,1}$) and ($A_{1,2}^- - A_{1,2}$) (Sections III,B,2,b, and c) as constructed from the absorption changes in TSF-I particles poised at -0.62 V and at cryogenic temperatures suggest that $A_{1,1}^-$ is an anion radical of Chl *a* and $A_{1,2}^-$ an Fe-S center. Additional

support for these suggestions has been obtained from other ESR-spectroscopic measurements, which will be summarized here.

As shown in Fig. 16, left top, in TSF-I particles poised at -0.62 V and at 56°K , the kinetics of the ESR signals in the $g = 2.00$ region also has two exponential-decay components with lifetimes of 1.3 msec and ~ 100 msec (130 msec at 7°K). The ESR spectrum constructed from the 1.3-msec decay component is asymmetric, shifted to a higher g value (2.004 ± 0.0005), and has a ΔH_{pp} of 10 G (Shuvalov *et al.*, 1979a). One may assume the latter spectrum to be a composite of two radical signals, one of which is due to P700^+ and the other to Chl^- .

An ESR spectrum that is presumably due to $\text{A}_{1,1}^-$ has been isolated in a Triton- or SDS-fractionated PSI particle in the presence of dithionite and under intense illumination followed by freezing under illumination (Heathcote *et al.*, 1980; Baltimore and Malkin, 1980a). The ESR spectrum has a g -value of 2.0025 and an ΔH_{pp} from 10 to 14 G. From these ESR results, $\text{A}_{1,1}^-$ was assigned to an anion radical of either Chl or Ph. ENDOR spectroscopy suggests that $\text{A}_{1,1}^-$ is most likely a monomeric Chl a anion radical (Fajer *et al.*, 1980).

For the 130-msec decay component, a kinetic correlation was made

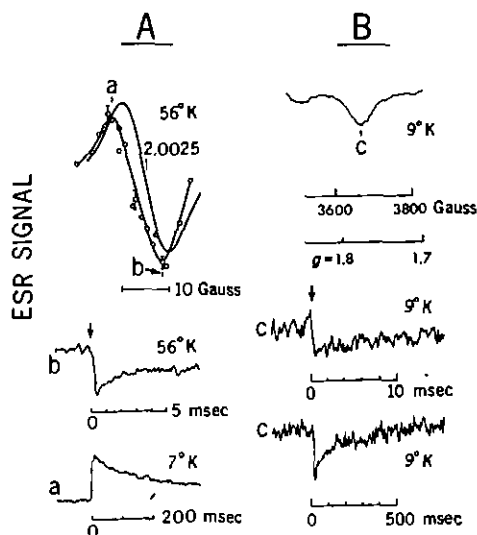

FIG. 16. (A, top) The plain continuous curve: light-minus-dark ESR spectrum of the 100-msec decay component, measured using continuous illumination of TSF-I fragments poised at -0.62 V and at 56°K . Curve with open circles: amplitude of ESR spectrum of flash-induced 1.3-msec decay component with the same sample. (A, center) Kinetics of flash-induced ESR-signal change at point (b) of the top spectrum, measured with a time resolution of ~ 200 μsec at 56°K . (A, bottom) Kinetics of flash-induced ESR signal change at point (a) of the top spectrum, measured with a time resolution of 6 msec at 7°K . (B, top) Light-minus-dark ESR spectrum of TSF-I fragments poised at -0.62 V and at 9°K in the $g = 1.78$ region measured with continuous illumination. (B, center and bottom) Kinetics of flash-induced ESR signal change at point (c) of the top spectrum on different time scales. (From Shuvalov *et al.*, 1979a.)

with the ESR signal of the Fe-S center designated as "X." Figure 16, top right, shows the light-minus-dark ESR spectrum at 9°K of T₂SF-I particles poised at -0.62 V in the $g = 1.78$ region characteristic of X (McIntosh *et al.*, 1974; Heathcote *et al.*, 1978). The risetime for the formation of this ESR signal was limited by the time response of 200 μ sec of our instrument (right, middle trace, Fig. 16). The signal decay has a single component with $t_{\frac{1}{2}} \sim 130$ msec (right, bottom trace, Fig. 14), which agrees with the optical signal measured for the reversal of the (P700⁺·A_{1,2}⁻) state (Section III,B,2,b). Thus, these data are consistent with the assumption that A_{1,2} and X represent the same acceptor, probably another Fe-S center.

5. KINETICS OF ELECTRON TRANSFER FROM D_{1,2} TO P700⁺

In subchloroplast particles, which are often deprived of the endogenous donors as a result of solubilization or inactivation, P700⁺ formed during charge separation is forced to recover by recombining with one of the reduced acceptors or with an externally furnished secondary donor molecule. In normal photosynthesis, P700⁺ recovers by accepting an electron ultimately generated by PSII. The question of whether Cyt *f* or plastocyanin is the immediate physiological electron donor to P700⁺ has long been controversial (Kato, 1977).

Thus far, all available evidence indicates that Cyt *f* is not the direct electron donor to P700⁺. There is no kinetic (Hiyama and Ke, 1971c; Haehnel, 1975; Haehnel *et al.*, 1980b) or stoichiometric (Haehnel, 1975) correspondence between P700⁺ reduction and Cyt *f* oxidation; quantitation by "flash titration" showed that less than 15% of the electrons generated by PSII passed through Cyt *f* to P700⁺ (for further discussion, see Cramer and Crofts, Chapter 9, this volume).

Dark reduction of P700⁺ by electron carriers located between plastoquinone and P700 showed two kinetic components with halftimes of 20 and 200 μ sec (Bouges-Bocquet, 1977; Haehnel, 1977; Van Best and Mathis, 1978). The latter was initially assumed to represent P700⁺ reduction by plastocyanin. The temperature dependence of the 200 μ sec reduction of P700⁺ yielded an activation energy of 2.2 kcal·mol⁻¹ (Haehnel, 1978), a value much lower than expected for a diffusion-controlled process. There are other indications that plastocyanin may be structurally bound to the thylakoid membrane (Sane and Hauska, 1972; Ke *et al.*, 1975), thus providing close association with P700.

When the 20- μ sec decay kinetics of P700 reduction and oxidation of plastocyanin and Cyt *f* were examined simultaneously, it was found that although a high proportion of P700⁺ was reduced 5–10 μ sec after an excitation flash, no oxidation of either Cyt *f* or plastocyanin was observed within this time (Bouges-Bocquet and Delosme, 1978). This ob-

ervation led to the suggestion that an unknown intermediary electron donor (designated "PD") must be present between plastocyanin and P700: $\text{Cyt } f \rightarrow \text{PC} \rightarrow \text{PD} \rightarrow \text{P700}$. About the same time, it was found that one of the six subunits (subunit III) fractionated from PSI reaction-center particles was required for electron transfer from plastocyanin to P700^+ (Bengis and Nelson, 1977). The "PD" could be a bound form of plastocyanin.

Kinetic-spectroscopic examination of P700^+ reduction in chloroplasts, in the presence of 3 mM MgCl_2 and 200 mM sorbitol, shows that 70% of the total P700^+ recovers with a halftime of 20 μsec (Haehnel *et al.*, 1980a,b). The fast decay phase has been attributed to a direct reduction of P700^+ by closely complexed plastocyanin. The formation of a complex between plastocyanin and P700 is apparently favored by a compensation of surface charges of the membrane by added cations and by a diminishing internal volume of the thylakoids at increasing osmolarity of the solution. These new results favor the complexed plastocyanin as the immediate donor to P700. Haehnel *et al.* (1980b) also found Cyt *f* oxidation to occur in two phases, at 70–130 μsec and 440–860 μsec and tentatively ascribed them to electron transfers to plastocyanin oxidized in 20 μsec and 200 μsec , respectively. The 200- μsec phase is attributed to a mobile pool of plastocyanin that mediates electron exchanges between PSI reaction centers.

C. Chloroplast Photosystem II

Charge separation in green plant PSII produces a strongly oxidizing primary donor (P680^+) and a moderately reducing primary acceptor. The redox potential of the primary donor couple $\text{P680}^+/\text{P680}$ is probably well over +0.8 volt, which is needed for water photolysis; it has been estimated to be around +1.1 V (see Jursinic and Govindjee, 1977; Klimov *et al.*, 1979). The stable acceptor is probably a membrane-bound plastoquinone molecule complexed with iron (Klimov *et al.*, 1980d; Nugent *et al.*, 1981). The redox potential of the plastoquinone acceptor(s) is still controversial. The transient electron acceptor in PSII, a pheophytin molecule, has been discovered only recently. For a recent review on electron acceptors of PSII, see Vermaas and Govindjee (1981).

1. THE PRIMARY ELECTRON DONOR P680

Because of the highly positive E_m (actual value yet undetermined), the oxidized-minus-reduced difference spectrum of the PSII primary electron donor, P680, has not yet been obtained by chemical means. The difference spectrum of P680 was first constructed from flash light-induced absorption-change transients in chloroplasts (Döring *et al.*, 1967)

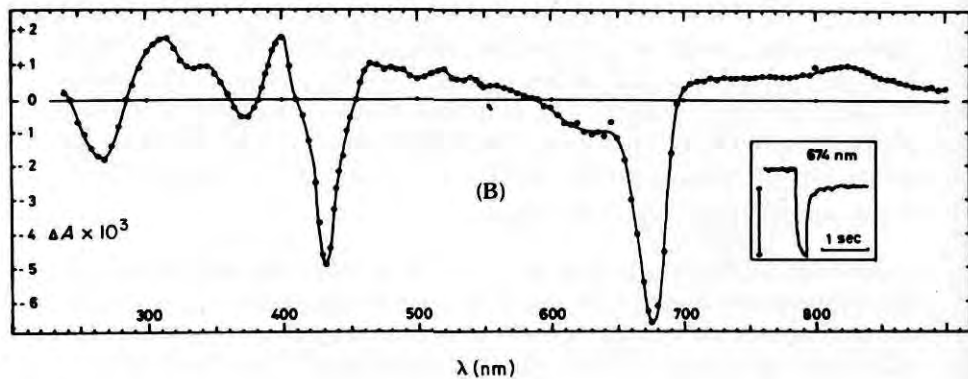
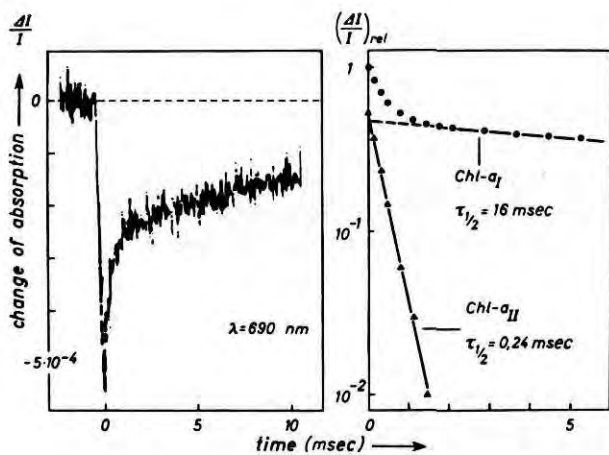
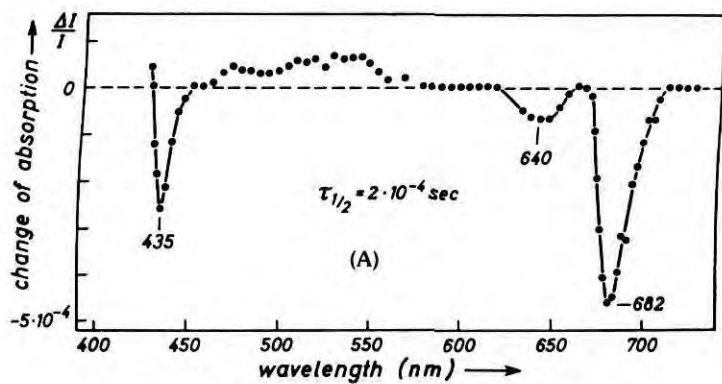

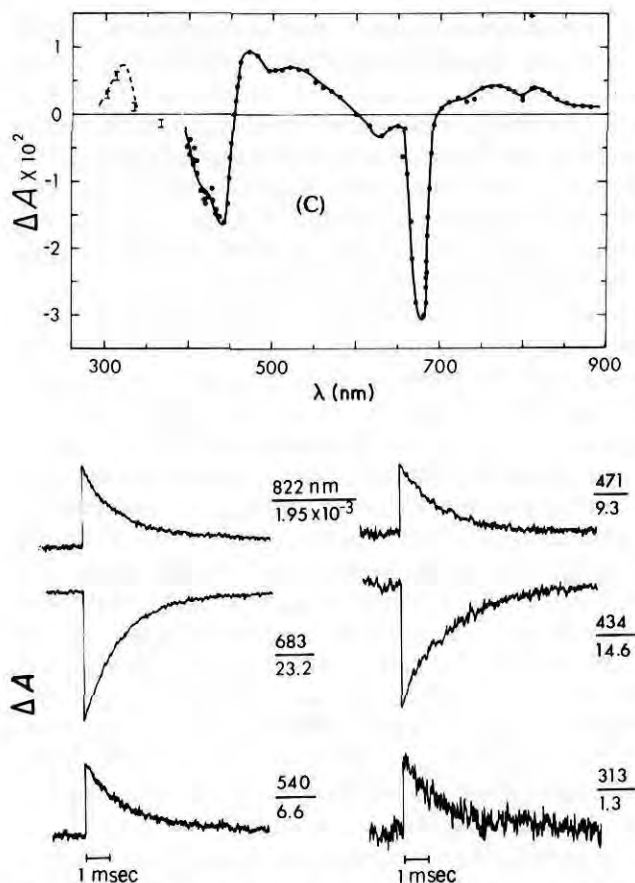

FIG. 17. Light-minus-dark difference spectra of absorption changes for (P680⁺ - P680) (A, B, and C) and (PQ⁻ - PQ) (B and C). (A) spectrum measured in whole spinach chloroplasts using 20- μ sec flash excitation. Absorption-change transient at 690 nm shown below. (B) Spectrum measured in subchloroplast fragments prepared with deoxycholate, using steady illumination (duration, 2 sec). Inset shows an absorption change at 674 nm. (C) Light-minus-dark difference spectrum of TSF-IIa fragments at 95°K. Typical absorption-change transients at several wavelengths are shown below. (A from Döring *et al.*, 1967; B from van Gorkom *et al.*, 1975; C from Ke and Dolan, 1980.)

(Fig. 17A, top). The chloroplast transients decay in two phases (Fig. 17A, bottom) with lifetimes of 200 μ sec and 20 msec, which were assigned to P680 and P700, respectively. The 200 μ sec decay time was attributed to the reduction of P680⁺ by a secondary donor, by inference with a similar decay time (Kok *et al.*, 1970) for the state change $S_1^* \rightarrow S_2$ on the oxidizing side of PSII (for an earlier review on P680, see Witt, 1975).

The initially reported absorption change for PSII (Döring *et al.*, 1967) was relatively small, and was thought not to be caused directly by the oxidation of P680, but rather to be an "indicator" change in response to P680 photo-oxidation. The small amplitude of the changes could also be due to an inadequate time resolution of the measuring technique. This proved to be the case, as a new component decaying in 35 μsec was subsequently observed with 1 μsec time resolution (Gläser *et al.*, 1974), and the total absorption change attributable to P680 agreed with the expected stoichiometry between the two photosystems.

P680 reactions can also be measured by an absorption increase at 825 nm which is associated with the cation radical formation (Haveman and Mathis, 1976). In untreated chloroplasts, P680 changes could not be detected with a time resolution of 3 μsec , which led to the conclusion that under physiological conditions, the reduction of P680⁺ must be faster than 3 μsec (van Best and Mathis, 1978). However, when chloroplasts are treated either by low pH, Tris washing, or exposure to detergent during fractionation, P680 absorption changes can readily be observed, and the decay time is usually in the 100–300 μsec range. The general consensus now is that the submicrosecond decay represents reduction of P680⁺ by the first secondary donor and the 200 μsec component represents recombination of P680⁺ with the reduced acceptor.

Using deoxycholate-treated chloroplasts (van Gorkom *et al.*, 1974) and subsequently also a PSII particle fractionated by digitonin treatment (van Gorkom *et al.*, 1975; Pulles *et al.*, 1976), the (P680⁺ - P680) difference spectrum could be obtained by steady illumination of the sample in the presence of ferricyanide (Fig. 17B). Ferricyanide presumably oxidizes the secondary donor(s) and facilitates the accumulation of P680⁺.

A difference spectrum from the UV to the near-IR consisting of predominantly P680 photo-oxidation at low temperatures has been measured recently in the Triton-fractionated subchloroplast fragments (TSF-IIa) (Ke and Dolan, 1980) (Fig. 17C). The decay in these absorption changes has been assigned to a recombination between P680⁺ and Q⁻ ($A_{II,2}^- \equiv Q_A^- \equiv Q_I^- \equiv PQ_I^-$). New experiments have suggested that some Chl triplet state might also be involved in this difference spectrum (B. Ke, unpublished experiments).

The ESR signal initially attributed to P680⁺ had a *g*-value of 2.003 and ΔH_{pp} of 8 G (Ke *et al.*, 1973b; Malkin and Bearden, 1973). However, because optical spectroscopy indicated that P680⁺ formed in the primary act does not accumulate, but recovers by reduction by either the first secondary donor or the primary acceptor, it was suggested that the free radical ESR signal initially attributed to P680⁺ probably belongs to an oxidized Chl molecule which may be the immediate secondary donor to P680⁺ (Malkin and Bearden, 1975; Visser, 1975).

2. DIRECT MEASUREMENT OF
THE ($A_{II,1}^- - A_{II,1}$) DIFFERENCE SPECTRUM

As in the photosynthetic bacteria and green plant PSI, an intermediary electron acceptor has been found recently in green plant PSII. The first clue came from the observation that in *Chlorella* cells, in which the stable acceptor Q was chemically reduced, a strong delayed fluorescence with a halftime of 700 nsec was observed after excitation with short laser flashes (van Best and Duysens, 1977). One possible origin of this delayed fluorescence was suggested to be the recombination between $P680^+$ and $A_{II,1}^-$ (called W^-). More direct evidence for an intermediary electron acceptor in PSII was obtained from absorption changes at about the same time (Klimov *et al.*, 1977). In a PSII particle ("DT-20") poised at a relatively positive potential (no addition or 10 μM ferricyanide), actinic illumination causes a fluorescence yield increase from F_0 to F_{max} ($\Delta F = F_{max} - F_0$), reflecting reduction of acceptor Q. However, when the PSII particle is poised under conditions so that acceptor Q is chemically reduced, the fluorescence yield induced by the weak probing beam rises instantly to the maximum level (F_{max}) comparable to that when Q is photochemically reduced. Upon illumination with strong actinic light, the fluorescence decreases, instead, to almost the F_0 level (F'_0). Under these conditions, absorption changes characteristic of reduction of a pheophytin were observed, instead of those related to the reduction of Q.

These fluorescence yield and absorption change characteristics have been confirmed also with chloroplasts and various detergent-fractionated PSII subchloroplast fragments (Klimov *et al.*, 1980b), including the TSF-IIa fragments highly enriched in PSII reaction center components (Klimov *et al.*, 1980a). The light-induced difference spectrum and a typical absorption change signal for the TSF-IIa fragments poised at -0.45 V are shown in Fig. 18. The spectrum is characterized by bleaching at 410, 422, 514, 545, and 685 nm, and by development of bands at 676, 655, 455, and 700 nm. Most recent experiments have shown that pheophytin is photoreduced in less than 2 nsec and recombines with $P680^+$ in ~ 4 nsec (Shuvalov *et al.*, 1980). The rate of oxidation of Ph^- by Q is yet unknown. The E_m of Ph/Ph^- in PSII has recently been measured to be -610 mV (Klimov *et al.*, 1979).

The unusual Chl *a* fluorescence yield changes in PSII under reducing conditions were interpreted on the thesis that the variable fluorescence may actually be delayed fluorescence arising from charge recombination in the state [$P680^+ \cdot Ph^-$] (Klimov *et al.*, 1977). Thus, the recombination luminescence would appear after illumination if Q was prerduced, but disappear if Ph was prerduced. This notion was supported by the find-

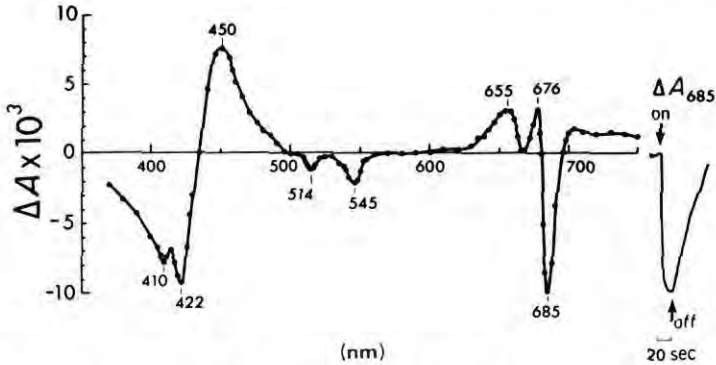

FIG. 18. Light-minus-dark difference spectrum of TSF-IIa fragments poised at ~ -0.45 V and at 295°K. The inset (trace on the right edge of the figure) shows the absorption-change transient at 685 nm on the same absorbance scale. (From Klimov *et al.*, 1980a.)

ing that ΔF has an activation energy of 0.047 eV in DT-20 particles and 0.075 eV in chloroplasts (Klimov *et al.*, 1978). F_{\max} was found to decay in two phases at 320 ± 30 psec and 3.2 ± 0.8 nsec in DT-20 fragments, whereas F'_0 only had a short-lived component (150 ± 30 psec) and the long-lived component (2–4 nsec) was almost absent. Thus, the luminescence decaying in 2–4 nsec can be assigned solely to ΔF (Klimov *et al.*, 1978; cf. Sorokin *et al.*, 1970; Sauer and Brewington, 1978).

The 4-nsec recombination luminescence has been confirmed with the TSF-IIa fragments (Shuvalov *et al.*, 1980). Furthermore, the formation of an ion radical pair in PSII has also been measured directly by nanosecond kinetic spectroscopy. At low redox potential, absorbance changes with 4-nsec lifetime are observed in PSII. The spectrum is consistent with the sum of spectra for the formation of the cation radical of the primary electron donor, $P680^+$, and of the anion radical, Ph^- . Both the absorbance changes and luminescence signals are diminished when the reaction centers are driven into the state $[P680 \cdot Ph^-]$ by continuous illumination at low redox potentials.

Trapping of Ph^- in PSII at 295°K is accompanied by the appearance of an ESR signal with $g = 2.0035$ and ΔH_{pp} of 12.5 G (Klimov *et al.*, 1980c), similar to that of the anion radical of Ph *in vitro* (Fujita *et al.*, 1978). At 6°K, this signal can be seen at low microwave power (0.1 mW) (Fig. 19 left, top), but is almost unobservable at 50 mW due to power saturation (Fig. 19 left, bottom). When Ph^- is trapped in TSF-IIa fragments at 220°K, the ESR spectrum at 6°K shows, in addition to the narrow singlet due to Ph^- with $g = 2.003$ and ΔH_{pp} of 13 G, a doublet centered at $g = 2.00$ with a splitting of 52–55 G (Fig. 19, right, top). The

split signal, in contrast to the singlet, is highly temperature sensitive and not detectable above 15°K (Fig. 19 right, bottom).

The split ESR signal detected after trapping Ph^- in PSII and that observed previously after trapping Bph^- under similar conditions in photosynthetic bacteria have similar g -values, magnitudes of splitting, and dependences of the signal amplitude on temperature and microwave power. These similarities indicate that the splitting of the ESR signal in PSII probably has the same origin as in photosynthetic bacteria, namely, an interaction between Ph^- and the singly reduced quinone, PQ^- (Q^-), which probably interacts with an iron atom. The involvement of plastoquinone as well as iron has recently been confirmed by extraction and reconstitution experiments (Klimov *et al.*, 1980d).

3. DIRECT DETECTION OF THE $[\text{P680}^+ \cdot \text{A}_{II,2}]$ STATE; KINETICS OF THE BACK-REACTION

The stable electron acceptor in PSII ($\text{A}_{II,2}$) has long been considered to be a membrane-bound plastoquinone molecule. Based on the hypothesis that the acceptor molecule Q (Q stands for quencher) in its oxidized

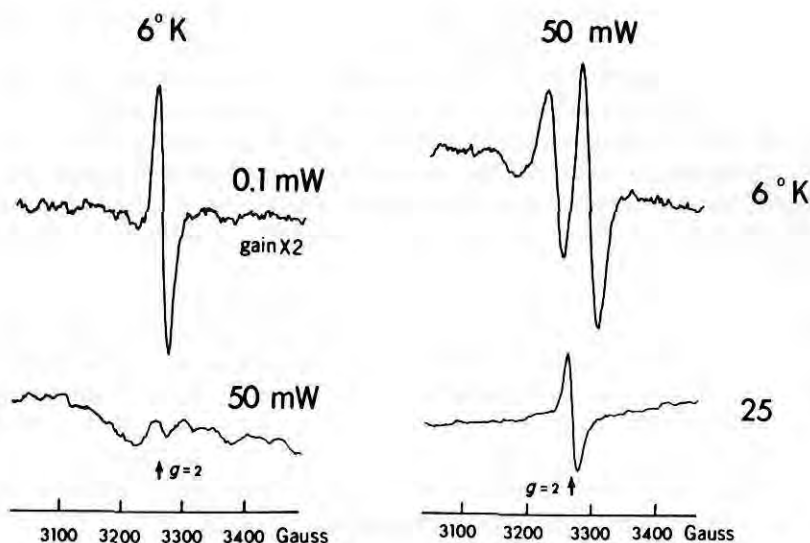

FIG. 19. (Left) ESR spectra (measured at 6°K) of TSF-IIa fragments after 30-sec illumination at 295°K (at ~ -0.45 V) followed immediately by freezing in liquid nitrogen under illumination. Top spectrum measured at 0.1 mW; bottom spectrum at 50 mW. (Right) ESR spectra of TSF-IIa fragments after 90-sec illumination at 220°K (at ~ -0.45 V) followed immediately by freezing in liquid nitrogen under illumination. Top spectrum measured at 6°K and 50 mW; bottom spectrum at 25°K and 50 mW. (From Klimov *et al.*, 1980a.)

state is a fluorescence quencher (Duysens and Sweers, 1963), the properties of Q have been studied by the fluorescence yield increase when $A_{11,2}$ is either photochemically or chemically reduced (see Lávorel and Etienne, 1977; cf. section III,C,2). The study of the stable electron acceptor of PSII has also been facilitated by the use of a specific inhibitor, diuron, which prevents electron transfer from the primary acceptor plastoquinone (Q) to the secondary plastoquinone B or R.

Early studies of spectral changes in the UV and visible regions led to kinetic identifications consistent with plastoquinone being an acceptor in PSII, and the species responsible for these changes was designated X320 (Stiehl and Witt, 1968). Subsequent studies (van Gorkom *et al.*, 1974, 1975; Pulles *et al.*, 1976) with detergent-fractionated subchloroplast fragments produced a difference spectrum which included features of both X320 and the spectral species C550 (see later) as well as $[PQ^- - PQ]$ *in vitro* (see Fig. 34 of Chapter 5). The membrane-bound plastoquinone molecule in PSII undergoes a one-electron reduction during charge separation. Absorption changes due to $A_{11,2}$ (PQ, X320, or C550) reduction can be observed at both room and cryogenic temperatures (van Gorkom *et al.*, 1974; Haveman *et al.*, 1975; Ke and Dolan, 1980). Also, their decay kinetics are identical to that of $P680^+$ whenever the electron transport from the first secondary donor is prevented.

Absorption changes at 550 nm (due to C550) are considered not to reflect the reduction of the acceptor itself directly, but rather to be a spectral shift responsive to the electric field of the reduced acceptor. This conclusion is based on the observation that chloroplasts extracted with nonpolar solvents can be reactivated by addition of plastoquinone, but restoration of C550 changes requires additional β -carotene (Okayama and Butler, 1972).

Light-induced absorption changes measured in TSF-IIa fragments by flash-kinetic spectroscopy at room and cryogenic temperatures have been attributed to $[P680^+ - P680] + (PQ^- - PQ)$ (Ke and Dolan, 1980) (Fig. 17C). Changes due to $(P680^+ - P680)$ occur largely in the visible region, while those due to $(PQ^- - PQ)$ occur largely in the UV region. Recombination between $P680^+$ and PQ^- is indicated by identical single, exponential decay kinetics observed at several wavelengths related to the two species and at different temperatures.

The recombination rate decreases rapidly with decreasing temperature down to about 210°K; below $\sim 210^\circ\text{K}$, the decay time remains constant at 1.25 ± 0.5 msec (activation energy is practically zero). The low temperature recombination time observed in the TSF-IIa fragments is slightly shorter than values (2–4 msec) reported by others. This variation suggests that the reaction time may be very sensitive to disturbance

of the architecture in the thylakoid membrane produced by different preparative procedures, including exposure to detergents.

The dependence of the fluorescence-quenching property of the PSII electron acceptor on its redox state has been utilized for the determination of its E_m . The first titration (Cramer and Butler, 1969) showed two quenching transitions at -35 mV and -270 mV (at pH 7), and showed that the midpoint potentials are pH dependent. The first, more positive quenching transition was initially considered to represent the "primary" electron acceptor of PSII. Subsequently, a similar titration with the TSF-IIa fragments enriched in PSII reaction center components (Ke *et al.*, 1977) showed predominantly the more negative transition. The actually measured E_m of -350 mV was later demonstrated (Horton and Croze, 1979) to be too negative as a result of the peculiar quenching action exerted by one of the mediators used (neutral-red). Nevertheless, the presence of two quenching centers in chloroplasts was confirmed (Horton and Croze, 1979; Malkin and Barber, 1979).

The exact functional roles of the two quenching centers are not yet known. One explanation is that the more negative value reflects a problem of inaccessibility of a fraction of the electron acceptors (Golbeck and Kok, 1979). Another suggestion is that the two quenching transitions may reflect separate electron acceptors operating in parallel (Horton and Croze, 1979; Malkin and Barber, 1979). This idea is consistent with various previous proposals that there is more than one "primary" acceptor in PSII (Joliot and Joliot, 1973; Melis and Homann, 1976). The two quenching transitions may correspond with the components which contribute to the 515-nm electrochromic absorption changes in chloroplasts (Malkin, 1978). For an up-to-date review on the various forms of Q (labeled as Q_L , Q_H ; Q_1 , Q_2 ; Q_α , Q_β , etc.) and the relationship between them, see Vermaas and Govindjee (1981).

The more negative quenching transition is unlikely to be associated with the intermediary electron acceptor ($A_{II,1}$), a pheophytin, as it is now known that the E_m of $A_{II,1}/A_{II,1}^-$ is substantially more negative than -300 mV (Klimov *et al.*, 1979).

4. KINETICS OF ELECTRON TRANSFER FROM $D_{II,2}$ TO $P680^+$

$P680^+$ in PSII is the primary oxidant that ultimately oxidizes water. The rate of $P680^+$ reduction by the closest electron donor ($D_{II,2}$) was initially revealed by fluorescence experiments (Mauzerall, 1972). In dark-adapted *Chlorella* cells, the fluorescence increase induced by 10 nsec N_2 -laser pulses had a 25-nsec induction phase. Based on the premise that the oxidized primary donor ($P680^+$) is also a fluorescence quencher (Butler, 1972), this 25 nsec fluorescence-induction phase was

later interpreted to represent "a priming reaction for the photosystem that makes oxygen." In *Chlorella* cells, in which the oxygen evolution system is still intact, the major phase of fluorescence induction is also rapid ($<1 \mu\text{sec}$) and is attributable to the reduction of P680^+ by the closest secondary donor (Duysens *et al.*, 1975). When chloroplasts are incubated with hydroxylamine, which prevents the secondary donor from reducing P680^+ rapidly, this rapid induction phase is replaced by a slower $20 \mu\text{sec}$ phase. Subsequently, when absorption changes were measured directly in untreated, dark-adapted chloroplasts using nanosecond excitation flashes and a rapid photometer, an absorption change at 820 nm decaying with $t_{1/2} = 25\text{--}45 \text{ nsec}$ was indeed observed (van Best and Mathis, 1978). This was reconfirmed by fluorescence-induction measurements in dark-adapted *Chlorella* cells (Sonneveld *et al.*, 1979). The 30 nsec decay component was observed, however, only on the first excitation flash in dark-adapted chloroplasts. It was explained that in dark-adapted chloroplasts, $\text{D}_{\text{II},2}$ is ready for electron donation, so that P680^+ formed by the flash is rapidly reduced (30 nsec) by $\text{D}_{\text{II},2}$. The rate of electron donation after subsequent flashes may indeed be somewhat slower (sub μsec to μsec) (Sonneveld *et al.*, 1979). In addition, some $\text{D}_{\text{II},2}^+$ may stay oxidized, so that after the second flash, some P680^+ is reduced by recombining with the reduced acceptor ($\text{A}_{\text{II},2}^-$) instead, with a halftime of $\sim 140 \mu\text{sec}$ (Conjeaud and Mathis, 1980).

At cryogenic temperatures when electron donation from $\text{D}_{\text{II},2}$ is prevented, P680^+ may also be reduced directly by the (high-potential) Cyt b_{559} (Mathis and Vermeglio, 1975). There is no indication that Cyt b_{559} is an intermediate in the electron transport chain on the donor side of PSII at room temperature.

Independent ESR studies have revealed rapidly reversible signals which appear to be the counterparts of the rapid absorption changes related to the secondary donor. A free radical ESR transient which is spectrally similar to those of "Signal II" ($g = 2.0046$, $\Delta H_{\text{pp}} = 19 \text{ G}$) has been found in chloroplasts. One signal (designated II_{vf} ; vf = very fast) is formed in less than $100 \mu\text{sec}$ and decays in $400\text{--}900 \mu\text{sec}$. If oxygen evolution is inhibited by Tris treatment or other means, the same transient decays 1000-fold more slowly (Signal II_{f}) (Blankenship *et al.*, 1975; Warden *et al.*, 1976). These signals (II_{vf} and II_{f}) probably correspond to $\text{D}_{\text{II},2}$ and a modified state of the same component, $\text{D}'_{\text{II},2}$, respectively. Information on the risetime of the II_{vf} signal (representing the $\text{D}_{\text{II},2}$ -to- $\text{D}'_{\text{II},2}$ step) would be necessary for correlating II_{vf} with the 30 nsec time of P680 reduction.

At the present time, absorption-change and fluorescence measurements have provided only indirect kinetic information on $\text{D}_{\text{II},2}$; no high-

resolution ESR spectrum is yet available for $\text{II}_{\text{v.f.}}$. ESR studies have, however, led to speculation that $\text{D}_{\text{II},2}$ may also be a quinonoid compound (Warden *et al.*, 1976; also cf. Okayama, 1974).

The oxidation of $\text{D}_{\text{II},2}$ (referred to as Y or Z_1 or Z) leads ultimately to the oxidation of water to O_2 (see Wydrzynski, Chapter 10, this volume, for details), and the reduction of $\text{A}_{\text{II},2}$ (referred to as Q, Q_A , Q_1 , PQ_1 , X-320, C550) leads to the reduction of the plastoquinone (PQ) pool. On the other hand, reduction of $\text{A}_{\text{I},3}$ [referred to as P430 Fe-S center(s)] leads to the reduction of NADP^+ to NADPH, and the oxidation of $\text{D}_{\text{I},2}$ (PD; bound plastocyanin) to the oxidation of PQ pool, completing the cycle. The chemical structures of the components involved and the details of electron and proton transport will be discussed by Cramer and Crofts (Chapter 9, this volume) for both green plants and photosynthetic bacteria.

Acknowledgments

We acknowledge with thanks the helpful suggestions and criticisms of D. Holten, V. V. Klimov, V. A. Shuvalov, and C. C. Schenck.

REFERENCES

- Akhmanov, S. A., Borisov, A. Y., Danielius, R. Y., Gadonas, R. A., Kozlowski, V. S., Piskarskas, A. S., Razjivin, A. P., and Shuvalov, V. A. (1980). *FEBS Lett.* **114**, 149–152.
- Andreeva, N. E., Barashkov, B. I., Zakharova, G. V., Shubin, V. V., and Chibisov, A. K. (1978). *Biophysics (Engl. Transl.)* **23**, 565–570.
- Baltimore, B. G., and Malkin, R. (1980a). *Photochem. Photobiol.* **31**, 485–490.
- Baltimore, B. G., and Malkin, R. (1980b). *FEBS Lett.* **110**, 50–52.
- Bearden, A. J., and Malkin, R. (1974). *Fed. Proc., Fed. Am. Soc. Exp. Biol.* **33**, 378.
- Bengis, N. C., and Nelson, N. (1977). *J. Biol. Chem.* **252**, 4564–4569.
- Blankenship, R. E., and Parson, W. W. (1978). *Annu. Rev. Biochem.* **47**, 635–653.
- Blankenship, R. E., and Parson, W. W. (1979a). In "Photosynthesis in Relation to Model Systems" (J. Barber, ed.), pp. 71–114. Elsevier, Amsterdam.
- Blankenship, R. E., and Parson, W. W. (1979b). *Biochim. Biophys. Acta* **545**, 429–444.
- Blankenship, R. E., Babcock, G. T., Warden, J. T., and Sauer, K. (1975). *FEBS Lett.* **51**, 287–293.
- Blankenship, R. E., Schaafsma, T. J., and Parson, W. W. (1977). *Biochim. Biophys. Acta* **461**, 297–305.
- Bouges-Bocquet, B. (1977). *Biochim. Biophys. Acta* **462**, 362–370.
- Bouges-Bocquet, B. (1980). *Biochim. Biophys. Acta* **590**, 223–233.
- Bouges-Bocquet, B., and Delosme, R. (1978). *FEBS Lett.* **94**, 100–104.
- Bowman, M. K., Budil, D. E., Closs, G. L., Kostka, A. G., Wraight, C. A., and Norris, J. R. (1981). *Proc. Natl. Acad. Sci. U.S.A.* **78**, 3305–3307.
- Boxer, S. G., Chidsey, C. E. D., and Roelofs, M. G. (1982). *J. Am. Chem. Soc.* **104**, 1452–1454.

- Breton, J., Roux, E., and Whitmarsh, J. (1975). *Biochem. Biophys. Res. Commun.* **64**, 1274-1277.
- Brody, S. S., and Rabinowitch, E. (1957). *Science* **125**, 555.
- Butler, W. L. (1972). *Proc. Natl. Acad. Sci. U.S.A.* **69**, 3420-3422.
- Butler, W. L., and Norris, K. H. (1962). *Biochim. Biophys. Acta* **66**, 72-77.
- Clarke, R. H., Connors, R. E., and Frank, H. A. (1976). *Biochem. Biophys. Res. Commun.* **71**, 671-675.
- Clayton, R. K. (1977). *Plant Cell Physiol., Spec. Issue* **3**, 87-96.
- Clayton, R. K., and Straley, S. C. (1970). *Biochem. Biophys. Res. Commun.* **39**, 1114-1119.
- Clayton, R. K., and Straley, S. C. (1972). *Biophys. J.* **12**, 64-79.
- Clayton, R. K., and Yau, H. F. (1972). *Biophys. J.* **12**, 867-881.
- Cogdell, R. J., Monger, T. G., and Parson, W. W. (1975). *Biochim. Biophys. Acta* **408**, 189-199.
- Conjeaud, H., and Mathis, P. (1979). *Photochem. Photobiol.* **29**, 833-837.
- Conjeaud, H., and Mathis, P. (1980). *Biochim. Biophys. Acta* **590**, 353-359.
- Conjeaud, H., and Mathis, P., and Pailotin, G. (1978). *Biochim. Biophys. Acta* **546**, 280-291.
- Cramer, W. A., and Butler, W. L. (1969). *Biochim. Biophys. Acta* **172**, 503-510.
- Davis, M. S., Forman, A., and Fajer, J. (1979a). *Proc. Natl. Acad. Sci. U.S.A.* **76**, 4170-4174.
- Davis, M. S., Forman, A., Hanson, L. K., Thornber, J. P., and Fajer, J. (1979b). *J. Phys. Chem.* **83**, 3325-3332.
- Debus, R. J., Okamura, M. Y., and Feher, G. (1981). *Biophys. J.* **33**, 19a (Abstr. M-AM-E4).
- Demeter, S., and Ke, B. (1977). *Biochim. Biophys. Acta* **462**, 770-774.
- DeVault, D. (1980). *Q. Rev. Biophys.* **13**, 387-564.
- Döring, G., Stiehl, H. H., and Witt, H. T. (1967). *Z. Naturforsch., B: Anorg. Chem., Org. Chem., Biochem., Biophys., Biol.* **22B**, 639-644.
- Dutton, P. L., Leigh, J. S., and Seibert, M. (1972). *Biochem. Biophys. Res. Commun.* **46**, 406-413.
- Dutton, P. L., Leigh, J. S., and Reed, D. W. (1973). *Biochim. Biophys. Acta* **292**, 654-664.
- Dutton, P. L., Kaufmann, K. J., Chance, B., and Rentzepis, P. M. (1975). *FEBS Lett.* **60**, 275-280.
- Duysens, L. N. M., and Sweers, H. E. (1963). In "Studies on Microalgae and Photosynthetic Bacteria" (Jpn. Soc. Plant Physiol., ed.), pp. 353-372. Univ. of Tokyo Press, Tokyo.
- Duysens, L. N. M., Den Haan, G. A., and Van Vest, J. A. (1975). *Proc. Int. Congr. Photosynth., 3rd, 1974*, pp. 1-12.
- Evans, M. C. W., Sihra, C. K., and Slabas, A. R. (1977). *Biochem. J.* **162**, 75-85.
- Fajer, J., Borg, D. C., Forman, A., Felton, R. H., Dolphin, D., and Vegh, H. (1974). *Proc. Natl. Acad. Sci. U.S.A.* **71**, 994-998.
- Fajer, J., Brune, D. C., Davis, M. S., Forman, A., and Spaulding, L. D. (1975). *Proc. Natl. Acad. Sci. U.S.A.* **72**, 4956-4960.
- Fajer, J., Davis, M. S., Brune, D. C., Forman, A., and Thornber, J. P. (1978). *J. Am. Chem. Soc.* **100**, 1918-1920.
- Fajer, J., Davis, M. S., Forman, A., Klimov, V. V., Dolan, E., and Ke, B. (1980). *J. Am. Chem. Soc.* **102**, 7143-7145.
- Feher, G. (1971). *Photochem. Photobiol.* **14**, 373-387.
- Feher, G., Issacson, R. A., McElroy, J. D., Ackerson, L. C., and Okamura, M. Y. (1974). *Biochim. Biophys. Acta* **368**, 135-139.
- Fenton, J. M., Pellin, M. J., Govindjee, and Kaufmann, K. J. (1979). *FEBS Lett.* **100**, 1-4.
- Fong, F. K., Koester, V. J., and Polles, J. S. (1976). *J. Am. Chem. Soc.* **98**, 6406-6408.
- Frank, H., McLean, M. B., and Sauer, K. (1979). *Proc. Natl. Acad. Sci. U.S.A.* **76**, 5124-5128.

- Friesner, R., Dismukes, G. C., and Sauer, K. (1979). *Biophys. J.* **25**, 277–294.
- Fuhrhop, J. H., and Mauzerall, D. (1969). *J. Am. Chem. Soc.* **91**, 4174–4181.
- Fujita, I., Davis, M. S., and Fajer, J. (1978). *J. Am. Chem. Soc.* **100**, 6280–6282.
- Gast, P., and Hoff, A. J. (1978). *FEBS Lett.* **85**, 183–188.
- Gast, P., and Hoff, A. J. (1979). *Biochim. Biophys. Acta* **548**, 520–535.
- Gläser, M., Wolff, C., Buchwald, H.-E., and Witt, H. T. (1974). *FEBS Lett.* **42**, 81–85.
- Godik, V. I., and Borisov, A. Y. (1979). *Biochim. Biophys. Acta* **548**, 296–308.
- Goedheer, J. C. (1978). *Biochim. Biophys. Acta* **292**, 665–676.
- Golbeck, J. H., and Kok, B. (1979). *Biochim. Biophys. Acta* **547**, 347–360.
- Govindjee, and Govindjee R. (1975). In "Bioenergetics of Photosynthesis" (Govindjee, ed.), pp. 1–50. Academic Press, New York.
- Govindjee, and Jursinic, P. (1979). *Photochem. Photobiol. Rev.* **4**, 125–205.
- Haberhorn, R., and Michel-Beyerle, M. E. (1977). *FEBS Lett.* **75**, 5–8.
- Haberhorn, R., and Michel-Beyerle, M. E. (1979). *Biophys. J.* **26**, 489–498.
- Haberhorn, R., Michel-Beyerle, M. E., and Marcus, R. A. (1979). *Proc. Natl. Acad. Sci. U.S.A.* **76**, 4185–4188.
- Haehnel, W. (1975). *Proc. Int. Congr. Photosynth., 3rd, 1974* Vol. 1, pp. 557–568.
- Haehnel, W. (1976). *Biochim. Biophys. Acta* **423**, 499–509.
- Haehnel, W. (1977). *Biochim. Biophys. Acta* **459**, 418–441.
- Haehnel, W. (1978). *Proc. Int. Congr. Photosynth., 4th, 1977* pp. 777–786.
- Haehnel, W., Hess, V., and Pröpper, A. (1980a). *FEBS Lett.* **111**, 79–82.
- Haehnel, W., Pröpper, A., and Krause, H. (1980b). *Biochim. Biophys. Acta* **593**, 384–399.
- Haveman, J., and Mathis, P. (1976). *Biochim. Biophys. Acta.* **440**, 346–355.
- Haveman, J., Mathis, P., and Vermeglio, A. (1975). *FEBS Lett.* **58**, 259–261.
- Heathcote, P., Williams-Smith, D. L., Sihra, C. K., and Evans, M. C. W. (1978). *Biochim. Biophys. Acta* **503**, 333–342.
- Heathcote, P., Timofeev, K. N., and Evans, M. C. W. (1980). *FEBS Lett.* **111**, 381–385.
- Hiyama, T., and Fork, D. (1980). *Arch. Biochem. Biophys.* **199**, 488–496.
- Hiyama, T., and Ke, B. (1971a). *Proc. Natl. Acad. Sci. U.S.A.* **68**, 1010–1013.
- Hiyama, T., and Ke, B. (1971b). *Biochim. Biophys. Acta* **267**, 160–171.
- Hiyama, T., and Ke, B. (1971c). *Biochim. Biophys. Acta* **226**, 320–327.
- Hiyama, T., and Ke, B. (1972a). *Biochim. Biophys. Acta* **267**, 160–171.
- Hiyama, T., and Ke, B. (1972b). *Proc. Int. Congr. Photosynth., 2nd, 1974* Vol. 1, pp. 491–497.
- Hoch, G. (1977). *Encycl. Plant Physiol., New Ser.* **5**, 136–146.
- Hoff, A. J. (1976). *Biochim. Biophys. Acta* **440**, 765–771.
- Hoff, A. J., Rademaker, H., van Grondelle, R., and Duysens, L. N. M. (1977). *Biochim. Biophys. Acta* **460**, 547–554.
- Holmes, N. G., van Grondelle, R., Hoff, A. J., and Duysens, L. M. N. (1976). *FEBS Lett.* **70**, 96–101.
- Holten, D., Gouterman, M., Parson, W. W., Windsor, M. W., and Rockley, M. W. (1976). *Photochem. Photobiol.* **23**, 415–423.
- Holten, D., Windsor, M. W., Parson, W. W., and Gouterman, M. (1978a). *Photochem. Photobiol.* **28**, 951–961.
- Holten, D., Windsor, M. W., Parson, W. W., and Thornber, J. P. (1978b). *Biochim. Biophys. Acta* **501**, 112–126.
- Holten, D., Hoganson, C., Windsor, M. W., Schenck, C. C., Parson, W. W., Migus, A., Fork, R. L., and Shank, C. V. (1980). *Biochim. Biophys. Acta* **592**, 461–477.
- Hopfield, J. J. (1974). *Proc. Natl. Acad. Sci. U.S.A.* **71**, 3640–3644.
- Horton, P., and Croze, E. (1979). *Biochim. Biophys. Acta* **545**, 188–201.

- Hsi, E. S. P., and Bolton, J. B. (1974). *Biochim. Biophys. Acta* **347**, 126–153.
- Joliot, P., and Joliot, A. (1973). *Biochim. Biophys. Acta* **305**, 302–316.
- Jortner, J. (1976). *J. Chem. Phys.* **64**, 4860–4867.
- Junge, W. (1976). In "Chemistry and Biochemistry and Plant Pigments" (T. W. Goodwin, ed.), pp. 233–333. Academic Press, New York.
- Jursinic, P., and Govindjee (1977). *Photochem. Photobiol.* **26**, 617–628.
- Kamogawa, K., Namiki, A., Nakashima, N., Yoshihara, K., and Ikegami, I. (1981). *Photochem. Photobiol.* **34**, 511–516.
- Kato, S. (1977). *Encycl. Plant Physiol., New Ser.* **5**, A. Trebst, ed. 247–252.
- Katz, J. J., and Norris, J. R. (1973). *Curr. Top. Bioenerg.* **5**, 41–75.
- Kaufmann, K. J., Dutton, P. L., Netzel, T. L., Leigh, J. S., and Rentzepis, P. M. (1975). *Science* **188**, 1301–1304.
- Kaufmann, K. J., Petty, K. M., Dutton, P. L., and Rentzepis, P. M. (1976). *Biochem. Biophys. Res. Commun.* **70**, 839–845.
- Ke, B. (1972). *Arch. Biochem. Biophys.* **152**, 70–77.
- Ke, B. (1973). *Biochim. Biophys. Acta* **303**, 1–33.
- Ke, B. (1975). *Proc. Int. Congr. Photosynth., 3rd, 1974* Vol. 1, pp. 373–382.
- Ke, B. (1978). *Curr. Top. Bioenerg.* **7**, 76–138.
- Ke, B., and Beinert, H. (1973). *Biochim. Biophys. Acta* **305**, 689–693.
- Ke, B., and Dolan, E. (1980). *Biochim. Biophys. Acta* **590**, 401–406.
- Ke, B., Hansen, R. E., and Beinert, H. (1973a). *Proc. Natl. Acad. Sci. U.S.A.* **70**, 2940–2945.
- Ke, B., Sahu, S., Shaw, E. R., and Beinert, H. (1973b). *Biochim. Biophys. Acta* **347**, 36–48.
- Ke, B., Sugahara, K., Shaw, E. R., Hansen, R. E., Hamilton, W. D., and Beinert, H. (1974). *Biochim. Biophys. Acta* **368**, 401–408.
- Ke, B., Sugahara, K., and Shaw, E. R. (1975). *Biochim. Biophys. Acta* **408**, 12–25.
- Ke, B., Hawkrige, F., and Sahu, S. (1976). *Proc. Natl. Acad. Sci. U.S.A.* **73**, 2211–2215.
- Ke, B., Dolan, E., Sugahara, K., Hawkrige, F., Demeter, S., and Shaw, E. R. (1977). *Plant Cell Physiol., Spec. Issue*, pp. 187–199.
- Ke, B., Demeter, S., Zamaraev, K. I., and Khairutdinov, R. F. (1979). *Biochim. Biophys. Acta* **545**, 265–284.
- Klimov, V. V., Klevanik, A. V., Shuvalov, V. A., and Krasnovsky, A. A. (1977). *FEBS Lett.* **82**, 183–186.
- Klimov, V. V., Allakhverdiev, S. I., and Paschenko, V. A. (1978). *Dokl. Akad. Nauk SSSR* **242**, 1204–1207.
- Klimov, V. V., Allakhverdiev, S. I., Demeter, S., and Krasnovsky, A. A. (1979). *Dokl. Akad. Nauk SSSR* **249**, 227–230.
- Klimov, V. V., Dolan, E., and Ke, B. (1980a). *FEBS Lett.* **112**, 97–100.
- Klimov, V. V., Allakhverdiev, S. I., Shutilova, N. I., and Krasnovsky, A. A. (1980b). *Sov. Plant Physiol. (Eng. Transl.)* **27**, 315–326.
- Klimov, V. V., Allakhverdiev, S. I., and Krasnovsky, A. A. (1980c). *Dokl. Akad. Nauk SSSR* **249**, 485–488.
- Klimov, V. A., Dolan, E., Shaw, E. R., and Ke, B. (1980d). *Proc. Natl. Acad. Sci. U.S.A.* **77**, 7227–7231.
- Knaff, D. B., and Malkin, R. (1973). *Arch. Biochem. Biophys.* **159**, 558–562.
- Kok, B. (1961). *Biochim. Biophys. Acta* **48**, 527–533.
- Kok, V., Forbush, B., and McGlorin, M. (1970). *Photochem. Photobiol.* **11**, 457–475.
- Kryukov, P. G., Letokhov, V. S., Matveetz, Y. A., Nikogosian, D. M., and Sharkov, A. V. (1979). In "Picosecond Phenomena" (C. V. Shank, E. Ippen, and S. L. Shapiro, eds.), pp. 158–166. Springer-Verlag, Berlin.
- Lavorel, J., and Etienne, A.-L. (1977). In "Primary Processes of Photosynthesis" (J. Barber, ed.), pp. 203–268. Elsevier, Amsterdam.

- Leigh, J. S., and Dutton, P. L. (1972). *Biochem. Biophys. Res. Commun.* **46**, 414–421.
- Leigh, J. S., and Dutton, P. L. (1974). *Biochim. Biophys. Acta* **357**, 67–77.
- Loach, P. A., Kung, M. C., and Hales, B. J. (1975). *Ann. N.Y. Acad. Sci.* **244**, 297–319.
- Lozier, R. H., and Butler, W. L. (1974). *Biochim. Biophys. Acta* **333**, 460–464.
- McIntosh, A. R., Chu, M., and Bolton, J. R. (1974). *Biochim. Biophys. Acta* **376**, 308–314.
- Malkin, R. (1978). *FEBS Lett.* **87**, 329–333.
- Malkin, R., and Barber, J. (1979). *Arch. Biochem. Biophys.* **173**, 169–178.
- Malkin, R., and Bearden, A. J. (1971). *Proc. Natl. Acad. Sci. U.S.A.* **68**, 16–19.
- Malkin, R., and Bearden, A. J. (1973). *Proc. Natl. Acad. Sci. U.S.A.* **70**, 294–297.
- Malkin, R., and Bearden, A. J. (1975). *Biochim. Biophys. Acta* **396**, 250–259.
- Mathis, P., and Vermeglio, A. (1975). *Biochim. Biophys. Acta* **369**, 371–381.
- Mathis, P., Sauer, K., and Remy, R. (1978). *FEBS Lett.* **88**, 275–278.
- Mauzerall, D. (1972). *Proc. Natl. Acad. Sci. U.S.A.* **69**, 1358–1362.
- Melis, A., and Homann, P. (1976). *Photochem. Photobiol.* **23**, 343–350.
- Michel-Beyerle, M. E., Scheer, H., Seidlitz, H., and Tempus, D. (1979). *FEBS Lett.* **100**, 9–12.
- Netzel, T. L., Rentzepis, P. M., Tiede, D. M., Prince, R. C., and Dutton, P. L. (1977). *Biochim. Biophys. Acta* **460**, 467–487.
- Norris, J. R., Scheer, H., Druyan, M. E., and Katz, J. J. (1974). *Proc. Natl. Acad. Sci. U.S.A.* **71**, 4897–4900.
- Nugent, J. H. A., Diner, B. A., and Evans, M. C. W. (1981). *FEBS Lett.* **124**, 241–244.
- Ogrodnik, A., Krüger, H. W., Orthuber, H., Haberkorn, R., and Michel-Beyerle, M. E. (1982). *Biophys. J.* **39**, 91–99.
- Okamura, M. Y., Isaacson, R. A., and Feher, G. (1975). *Proc. Natl. Acad. Sci. U.S.A.* **72**, 3491–3495.
- Okamura, M. Y., Isaacson, R. A., and Feher, G. (1979). *Biochim. Biophys. Acta* **546**, 394–417.
- Okayama, S. (1974). *Plant Cell Physiol.* **15**, 95–101.
- Okayama, S., and Butler, W. L. (1972). *Plant Physiol.* **49**, 769–774.
- Parson, W. W. (1967). *Biochim. Biophys. Acta* **131**, 154–172.
- Parson, W. W. (1978). In "The Photosynthetic Bacteria" (R. K. Clayton and W. R. Sistrom, eds.), pp. 455–469. Plenum, New York.
- Parson, W. W., and Cogdell, R. J. (1975). *Biochim. Biophys. Acta* **416**, 105–149.
- Parson, W. W., and Monger, T. G. (1977). *Brookhaven Symp. Biol.* **28**, 195–211.
- Parson, W. W., Clayton, R. K., and Cogdell, R. J. (1975). *Biochim. Biophys. Acta* **387**, 268–278.
- Parson, W. W., Schenck, C. C., Blankenship, R. E., Holten, D., Windsor, M. W., and Shank, C. V. (1978). In "Frontiers of Biological Energetics" (P. L. Dutton, J. S. Leigh, and A. Scarpa, eds.), pp. 37–44. Academic Press, New York.
- Pellin, M. J., Wright, C. A., and Kaufmann, K. J. (1978). *Biophys. J.* **24**, 361–367.
- Peters, K., Avouris, P., and Rentzepis, P. M. (1978). *Biophys. J.* **23**, 207–217.
- Philipson, K. P., Satoh, V. L., and Sauer, K. (1972). *Biochemistry* **11**, 4591–4594.
- Prince, R. C., and Dutton, P. L. (1976). *Arch. Biochem. Biophys.* **172**, 329–334.
- Prince, R. C., and Dutton, P. L. (1978). In "The Photosynthetic Bacteria" (R. K. Clayton and W. R. Sistrom, eds.), pp. 440–453. Plenum, New York.
- Prince, R. C., Leigh, J. S., and Dutton, P. L. (1976). *Biochim. Biophys. Acta* **440**, 622–636.
- Prince, R. C., Tiede, D. M., Thornber, J. P., and Dutton, P. L. (1977). *Biochim. Biophys. Acta* **462**, 467–490.
- Pulles, M. P. J., van Gorkom, H. J., and Verschoor, G. A. M. (1976). *Biochim. Biophys. Acta* **440**, 98–106.
- Rademaker, H., and Hoff, A. J. (1981). *Biophys. J.* **34**, 325–344.

- Rademaker, H., Hoff, A. J., and Duysens, L. N. M. (1979). *Biochim. Biophys. Acta* **546**, 248–255.
- Redi, M., and Hopfield, J. J. (1980). *J. Chem. Phys.* **72**, 6651–6660.
- Rockley, M. G., Windsor, M. W., Cogdell, R. J., and Parson, W. W. (1975). *Proc. Natl. Acad. Sci. U.S.A.* **72**, 2251–2255.
- Roelofs, M. G., Chidsey, C. E. D., and Boxer, S. G. (1982). *Chem. Phys. Lett.* **87**, 582–588.
- Romijn, J. C., and Amesz, J. (1976). *Biochim. Biophys. Acta* **423**, 164–173.
- Rumberg, B. (1964). *Z. Naturforsch., B: Anorg. Chem., Org. Chem., Biochem., Biophys., Biol.* **19B**, 707–716.
- Rutherford, A. W., and Evans, M. C. W. (1979). *FEBS Lett.* **104**, 227–230.
- Rutherford, A. W., Heathcote, P., and Evans, M. C. W. (1979). *Biochem. J.* **182**, 515–523.
- Sane, P. V., and Hauska, G. (1972). *Z. Naturforsch.*, **27B**, 932–938.
- Sarai, A. (1980). *Biochim. Biophys. Acta* **589**, 71–83.
- Sauer, K. (1975). In "Bioenergetics of Photosynthesis" (Govindjee, ed.), pp. 139–144. Academic Press, New York.
- Sauer, K., and Brewington, G. T. (1978). *Proc. Int. Congr. Photosynth., 4th, 1977* pp. 409–421.
- Sauer, K., Mathis, P., Acker, S., and Van Best, J. A. (1978). *Biochim. Biophys. Acta* **503**, 120–134.
- Sauer, K., Mathis, P., Acker, S., and Van Best, J. A. (1979). *Biochim. Biophys. Acta* **545**, 466–472.
- Schaffernicht, H., and Junge, W. (1981). *Photochem. Photobiol.* **34**, 223–232.
- Schenck, C. C., Parson, W. W., Holten, D., and Windsor, M. W. (1981a). *Biochim. Biophys. Acta* **635**, 383–392.
- Schenck, C. C., Parson, W. W., Holten, D., Windsor, M. W., and Sarai, A. (1981b). *Biophys. J.* **36**, 479–489.
- Schenck, C. C., Blankenship, R. E., and Parson, W. W. (1982). *Biochim. Biophys. Acta* **680**, 44–59.
- Setif, P., and Mathis, P. (1980). *Arch. Biochem. Biophys.* **204**, 477–485.
- Setif, P., Hervo, G., and Mathis, P. (1981). *Biochim. Biophys. Acta* **638**, 257–267.
- Shuvalov, V. A. (1976). *Biochim. Biophys. Acta* **430**, 113–121.
- Shuvalov, V. A., and Asadov, A. A. (1979). *Biochim. Biophys. Acta* **545**, 296–308.
- Shuvalov, V. A., and Klimov, V. V. (1976). *Biochim. Biophys. Acta* **440**, 587–599.
- Shuvalov, V. A., and Parson, W. W. (1981a). *Proc. Natl. Acad. Sci. U.S.A.* **78**, 957–961.
- Shuvalov, V. A., and Parson, W. W. (1981b). *Biochim. Biophys. Acta* **638**, 50–59.
- Shuvalov, V. A., Klimov, V. V., and Krasnovsky, A. A. (1976a). *Mol. Biol.* **10**, 326–337.
- Shuvalov, V. A., Krakhmaleva, I. N., and Klimov, V. V. (1976b). *Biochim. Biophys. Acta* **449**, 597–601.
- Shuvalov, V. A., Asadov, A. A., and Krakhmaleva, I. N. (1977). *FEBS Lett.* **76**, 240–245.
- Shuvalov, V. A., Klevanik, A. V., Sharkov, A. V., Matveetz, Y. A., and Kryukov, P. G. (1978). *FEBS Lett.* **91**, 135–139.
- Shuvalov, V. A., Dolan, E., and Ke, B. (1979a). *Proc. Natl. Acad. Sci. U.S.A.* **76**, 770–773.
- Shuvalov, V. A., Ke, B., and Dolan, E. (1979b). *FEBS Lett.* **100**, 5–8.
- Shuvalov, V. A., Klevanik, A. V., Sharkov, A. V., Kryukov, P. G., and Ke, B. (1979c). *FEBS Lett.* **107**, 313–316.
- Shuvalov, V. A., Klimov, V. V., Dolan, E., Parson, W. W., and Ke, B. (1980). *FEBS Lett.* **118**, 279–282.
- Slooten, L. (1972). *Biochim. Biophys. Acta* **275**, 208–218.
- Sonneveld, A., Rademaker, H., and Duysens, L. N. M. (1979). *Biochim. Biophys. Acta* **548**, 536–551.

- Sorokin, E. M., Festisova, Z. G., and Tumerman, L. A. (1970). *J. Spectrosc.* **13**, 439-443.
- Stiehl, H. H., and Witt, H. T. (1968). *Z. Naturforsch.*, **23B**, 220-224.
- Straley, S. C., Parson, W. W., Mauzerall, D. C., and Clayton R. K. (1973). *Biochim. Biophys. Acta* **305**, 597-609.
- Thurnauer, M. C., Katz, J. J., and Norris, J. R. (1975). *Proc. Natl. Acad. Sci. U.S.A.* **72**, 3270-3274.
- Tiede, D. M., Prince, R. C., Reed, G. H., and Dutton, P. L. (1976a). *FEBS Lett.* **65**, 301-304.
- Tiede, D. M., Prince, R. C., and Dutton, P. L. (1976b). *Biochim. Biophys. Acta* **449**, 447-469.
- Trosper, T. L., Benson, D. L., and Thornber, J. P. (1977). *Biochim. Biophys. Acta* **460**, 318-330.
- Uphus, R. A., Norris, J. R., and Katz, J. J. (1974). *Biochem. Biophys. Res. Commun.* **61**, 1057-1063.
- van Best, J. A., and Duysens, L. N. M. (1977). *Biochim. Biophys. Acta* **459**, 187-206.
- van Best, J. A., and Mathis, P. (1978). *Biochim. Biophys. Acta*, **503**, 178-188.
- van Gorkom, H. J. (1974). *Biochim. Biophys. Acta* **347**, 439-442.
- van Gorkom, H. J., Tamminga, J. J., Haveman, J., and Van Der Linden, I. K. (1974). *Biochim. Biophys. Acta* **347**, 417-438.
- van Gorkom, H., Pulles, M. P. J., and Wessels, J. S. C. (1975). *Biochim. Biophys. Acta* **408**, 331-339.
- van Grondelle, R., Romijn, J. C., and Holmes, N. G. (1976). *FEBS Lett.* **72**, 187-192.
- van Grondelle, R., Holmes, N. G., Rademaker, H., and Duysens, L. N. M. (1978). *Biochim. Biophys. Acta* **503**, 10-25.
- Vermaas, W. F. J., and Govindjee (1981). *Photochem. Photobiol.* **34**, 775-793.
- Vermeglio, A. (1977). *Biochim. Biophys. Acta* **459**, 516-524.
- Vermeglio, A., and Clayton, R. K. (1977). *Biochim. Biophys. Acta* **461**, 159-165.
- Visser, J. W. M. (1975). Ph.D. Thesis, University of Leiden.
- Visser, J. W. M., Rijersberg, K. P., and Amesz, J. (1974). *Biochim. Biophys. Acta* **368**, 235-246.
- Warden, J. T., Blankenship, R. E., and Sauer, K. (1976). *Biochim. Biophys. Acta* **423**, 462-478.
- Warshel, A. (1980). *Proc. Natl. Acad. Sci. U.S.A.* **77**, 3105-3109.
- Wasielewski, M. R., Norris, J. R., Crespi, H. L., and Harper, J. (1981). *J. Am. Chem. Soc.* **103**, 7664-7665.
- Werner, H.-J., Schulten, K., and Weller, A. (1978). *Biochim. Biophys. Acta* **502**, 255-268.
- Witt, H. T. (1975). In "Bioenergetics of Membranes" (Govindjee, ed.), pp. 493-554. Academic Press, New York.
- Witt, K., and Wolff, C. (1970). *Z. Naturforsch.*, **25B**, 387-388.
- Wraight, C. A. (1977). *Biochim. Biophys. Acta* **459**, 525-531.
- Wraight, C. A. (1978). *FEBS Lett.* **93**, 283-288.
- Wraight, C. A. (1979). *Photochem. Photobiol.* **30**, 767-776.
- Wraight, C. A., and Clayton, R. K. (1973). *Biochim. Biophys. Acta* **333**, 246-260.
- Wraight, C. A., Leigh, J. S., Dutton, P. L., and Clayton, R. K. (1974). *Biochim. Biophys. Acta* **333**, 401-408.
- Yamamoto, H., and Vernon, L. P. (1969). *Biochemistry* **8**, 4131-4137.
- Zakharova, N. I., and Chibisov, A. K. (1977). *Dokl. Akad. Nauk SSSR* **237**, 340-342.
- Zamarav, K. I., and Khairutdinov, R. F. (1974). *Chem. Phys.* **4**, 181-194.

Part IV

Electron Transport

Electron and Proton Transport

WILLIAM A. CRAMER
ANTONY R. CROFTS

I. Introduction.....	389
II. Mechanism of Electron Transfer.....	391
A. General Considerations.....	391
B. Specific Examples.....	396
III. Properties of Quinones.....	398
A. Quinone Species.....	398
B. Electron and Proton Transfer Reactions in Solution.....	399
C. Reduction of Cytochrome <i>c</i> by $Q^{\cdot-}$ and $QH^{\cdot-}$ in Solution.....	400
D. Stability and Relative Reducing Strength of the Semiquinone Species.....	400
E. Spectroscopic Properties of Ubi- and Plastosemiquinone.....	401
F. Quinone Mobility in Membranes.....	402
IV. Primary and Secondary Quinone Acceptors.....	404
A. Methods for the Measurements of the Electron Transfer Properties of the Primary Acceptor.....	405
B. Properties of the Primary Acceptor Complex of the Bacteria.....	407
C. Primary Quinone Electron Acceptor Complex of the Photosystem II.....	409
D. The Secondary Electron Acceptor in Chloroplasts and Algae.....	412
E. Quinone-Binding Proteins.....	415
F. Membrane Surface Potential in Photosystem II.....	417
V. Cytochromes.....	418
A. Protein Chemistry.....	418
B. The Cytochrome <i>b-c</i> ₁ Complexes.....	419
C. Kinetics of Electron Transfer.....	421
D. Chloroplast Cytochrome <i>b</i> ₅₅₉ : Properties and Function.....	424
E. The Cyclic Electron Transfer Chain of <i>Rp. sphaeroides</i> and <i>Rp. capsulata</i>	427
F. Reductants for Cytochrome <i>b</i> ₅₆₁	429
G. Role of Cytochrome <i>b</i> ₅₆₆	430
VI. The Electron Donors to P700 and P870.....	431
VII. Vectorial Electron Transport.....	435
A. Background.....	435
B. Mechanism of the Carotenoid Spectral Shift.....	437
C. Characteristics of the Carotenoid Shift in <i>Rp. sphaeroides</i>	439
D. Electrogenic Events Indicated by Electrochromic Changes.....	441
E. The Slow Electrochromic Phase in Chloroplasts and Algae.....	442
F. Vectorial H^+ Translocation—The Role of Diffusible Quinone.....	445
G. A Modified Q-Cycle Mechanism.....	447
VIII. Protolytic Reactions.....	449
A. General Considerations.....	449
B. Chloroplast Photosystem II—Donor Side.....	450

C. Photosystem II—Acceptor Side.....	453
D. Characteristics of Rapid H ⁺ Uptake in Chromatophores.....	454
References.....	457

ABBREVIATIONS

ADRY	Acceleration of the deactivation reactions of the water splitting enzyme system Y
<i>Chr.</i>	<i>Chromatium</i>
Cyt	Cytochrome
DBMIB	2,5-Dibromo-3-methyl-6-isopropyl-benzoquinone
DCIP	2,6-Dichlorophenolindophenol
DCMU	3-(3,4-Dichlorophenyl)-1,1-dimethylurea
DPPC	Dipalmitoylphosphatidylcholine
DQ	2,3,5,6-Tetramethyl- <i>p</i> -benzoquinone (duroquinone)
E_{m7}	Midpoint oxidation-reduction potential at pH 7
E_n	Redox potential
ESR	Electron spin (paramagnetic) resonance
HOQNO	2 <i>n</i> -Heptyl-4-hydroxyquinoline N-oxide
HP	High potential
IP	Intermediate potential
KD	Kilodalton
K_d	Dissociation constant
LP	Low potential
LHCP	Light-harvesting chlorophyll-protein complex
M_r	Relative molecular weight measured by SDS-PAGE electrophoresis
PC	Plastocyanin
PQ	Plastoquinone
PS	Photosystem
Q_A	First quinone acceptor ($\equiv Q_1$)
<i>Rs.</i>	<i>Rhodospirillum</i>
<i>Rp.</i>	<i>Rhodopseudomonas</i>
RFeS	Rieske iron-sulfur center
SU	Subunit
TMQ	Trimethyl- <i>p</i> -benzoquinone
μC	Microcoulombs
UHDBT	5- <i>n</i> -Undecyl-6-hydroxy-4,7-dioxobenzothiazole
UQ	Ubiquinone
UV	Ultraviolet

ABSTRACT

The photosynthetic electron transport chains of green plants and bacteria are reviewed and discussed from a variety of points of view.

1. *Components.* The present state of knowledge of the redox components of the electron transfer chains is reviewed. Where possible, the relation between prosthetic groups, identified by biophysical methods, and the subunits, proteins or enzymes with which they are functionally associated, is presented. The components are discussed in terms of their thermodynamic properties, the kinetics of their interac-

tion with other components, their topographical distribution, and their involvement in proton pumping mechanisms.

2. *Kinetics of electron transport.* Marcus' theory is briefly reviewed, with some applications in photosynthesis. Measured rates of electron transfer processes are discussed in the context of several models for the arrangement of the dark electron transfer chains and for the mechanism of proton pumping.
3. *Thermodynamics of electron transfer.* The equilibrium redox potentials of components known to be involved in the electron transfer chains are reviewed and discussed. The modification of these potentials under operating conditions (operational redox potentials) is briefly discussed.
4. *Quinones.* The redox potentials of the couples of the quinone/semiquinone/quinol systems involved in electron transfer are discussed, with emphasis on the role of proteinaceous binding sites in stabilizing semiquinone species and the involvement of "bound" quinones in electron transfer. The role of bulk quinones in distributing electrons between chains is treated, and the mobility of quinones is discussed in terms of this distributive function and in terms of the possible role of quinones as H carriers in chemiosmotic H⁺ pumping mechanism.
5. *Topography of the chains.* The arrangement of components in the membrane is briefly discussed and related to models for proton pumping.
6. *Electrochromic absorbance changes—the "membrane voltmeter."* Electrochromic theory is briefly reviewed, and recent advances in our understanding of the mechanism of the carotenoid electrochromic change in photosynthetic bacteria are discussed.
7. *Protolytic reactions—the sites of H⁺ uptake and release.* The measurement of protolytic reactions is reviewed, and recent results discussed in the context of known electron transfer reactions and their involvement in proton pumping.
8. *Models.* The aspects of electron transfer summarized above are critically discussed in the context of several current models for the mechanism of electron transfer and proton transport. Most workers have adopted variants of the Q cycle to explain their results; possible Q-cycle mechanisms for the operation of the intersystem chain in chloroplasts and the cyclic chains of *Rp. sphaeroides* and *Rp. capsulata* are discussed.

I. Introduction

The purpose of this chapter is to provide an overview of current facts and concepts related to photosynthetic electron and proton transport in higher plants, algae, and photosynthetic bacteria. It is hoped that this chapter will provide basic information, in the field of electron transport and energy coupling, to beginning students as well as to advanced researchers.*

*For earlier work on these topics, the editor recommends that the readers consult chapters by M. Avron (electron flow); Govindjee and R. Govindjee (electron flow: general); A. T. Jagendorf (photophosphorylation); J. Lavorel (delayed light emission); S. Murakami *et al.* (structure of membrane and ion transport); G. Papageorgiou (chlorophyll *a* fluorescence); and H. T. Witt (electron flow and energy conservation) in "Bioenergetics of Photosynthesis," (Govindjee, ed.) Academic Press, New York (1975).

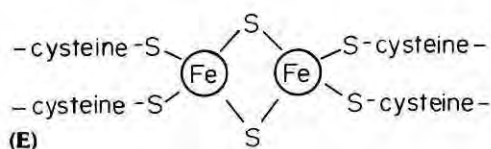
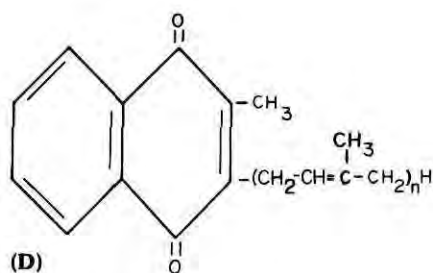
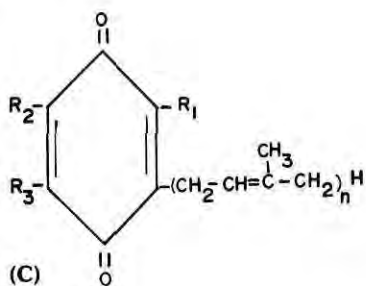
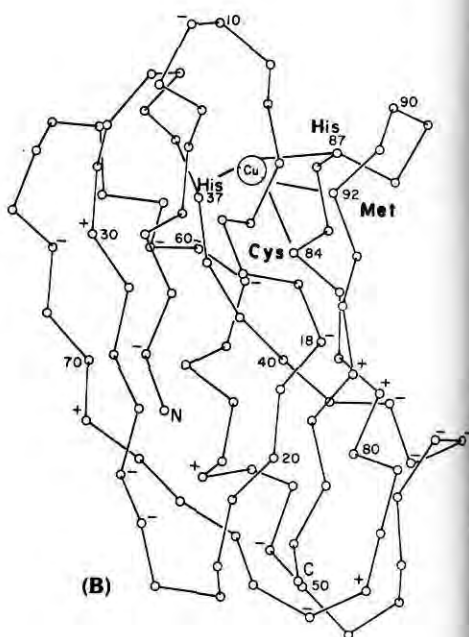
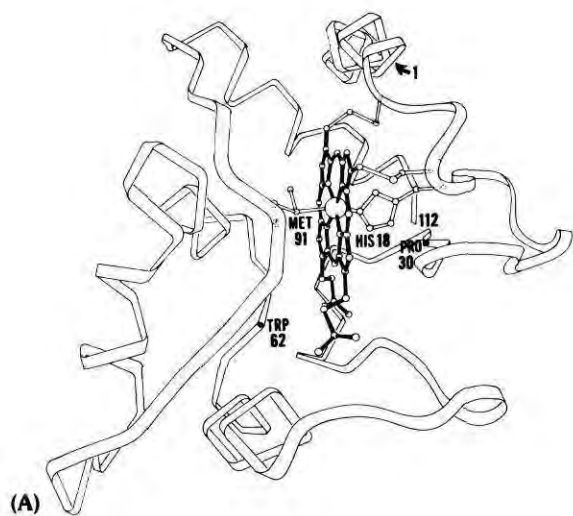

FIG. 1. Structures of prosthetic groups of redox compounds involved in plant and bacterial photosyntheses. (A) Structure of Cyt C_2 from *Rp. rubrum*, viewed from the "front" of the protein showing the exposed heme edge. This figure is obtained from the work of F. R. Salemme, whose discussion of these data is found in Salemme (1977). (B) Structure of spinach plastocyanin. This figure was redrawn by D. W. Krogmann, using the original figure of Freeman and co-workers (Colman *et al.*, 1978) and other sequence data. (C) Structure of ubiquinone and plastoquinone with substituent groups and isoprenoid chain length.

	R ₁	R ₂	R ₃	n
UQ	CH ₃	CH ₃ O	CH ₃ O	10
PQ	H	CH ₃	CH ₃	9

(D) Structure of menaquinone found in some photosynthetic bacteria. $n = 7$ in the purple nonsulfur bacterium *Chr. vinosum*, where the isoprenoid chain length is also seven units. (E) Structure of iron-sulfur linkage characteristic of $2\text{Fe} - 2\text{S}^*$ cluster found in soluble low potential plant ferredoxins and perhaps the high potential Rieske iron-sulfur protein as well.

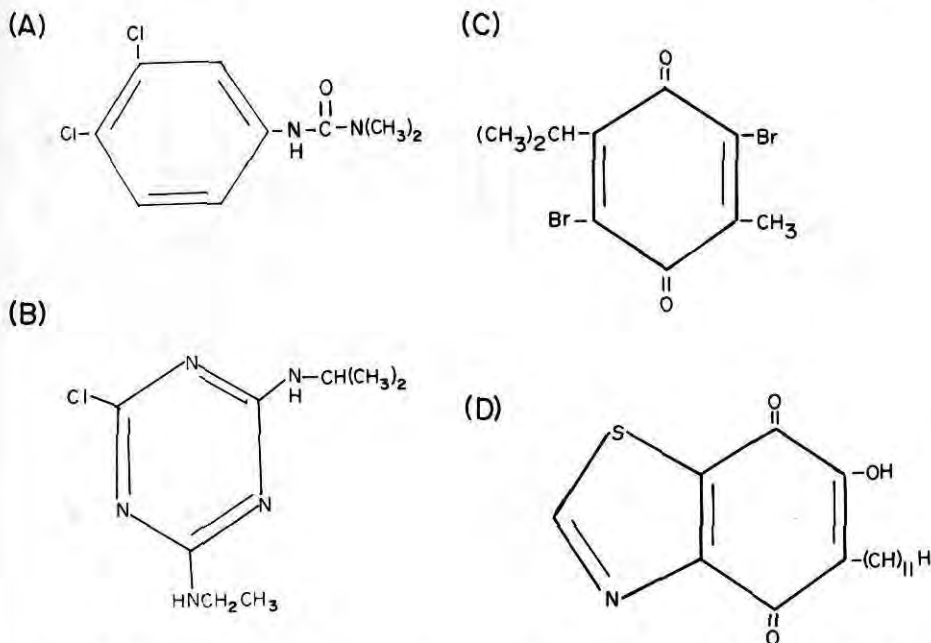

FIG. 2. Commonly used inhibitors of photosynthetic electron transport: (A) DCMU, (B) atrazine, (C) DBMIB, and (D) UHDBT.

A summary of the chemical structures of some of the oxidation-reduction compounds present in photosynthetic electron transport is presented in Fig. 1. These compounds include the heme protein cytochrome c_2 (Cyt c_2), the copper protein plastocyanin (PC), plastoquinone (PQ), and ubiquinone (UQ), and the iron-sulfur (Fe-S) cluster thought to be active in ferredoxin and the high potential Rieske Fe-S center. A summary of the redox proteins, their molecular weights, and approximate midpoint potentials in situ is shown for chloroplasts and algae (Table I). A summary of the chemical structures of commonly used inhibitors of electron transport, DCMU, atrazine, DBMIB, and UHDBT is shown in Fig. 2.

II. Mechanisms of Electron Transfer

A. General Considerations

Electron transfer reactions between metal (M) redox centers in solution coordinated by one or more ligands (L),

TABLE I
Molecular Weight and E_m of Isolated Chloroplast¹ and Algal Electron Transport Proteins

Proteins	M_r ($\times 10^3$)	E_m (mV)	Reference
PSII:			
Mn protein (<i>Scenedesmus obliquus</i>)	92	—	Metz <i>et al.</i> (1980)
P680 Complex (barley)	46	—	von Wettstein <i>et al.</i> (1980)
Herbicide binding Q_A -protein	32	—	Steinback <i>et al.</i> (1981)
Cytochrome b_{559}	5.5 (SU) ² 46 (eight SU) 111 (lipoprot.)	Ascorbate- reducible	Oettmeier <i>et al.</i> (1980) Garewal and Wasserman (1974) Wasserman (1980)
(<i>Bumilleriopsis filiformis</i>)	37 17 ~6 (SU) ~6 (SU)	Ascorbate- reducible	Lach and Böger (1977a) Lach and Böger (1977a) Zielinski and Price (1980)
Cytochrome b_{560} (soluble)	30	—	Satoh (1981)
PSI:		130	Matsuzaki and Kamimura (1972)
Cytochrome f (monomer)	35	—	Nelson and Racker (1972)

36	(Radish)	—	Ho and Krogmann (1980)
38	(<i>Spirulina maxima</i>)	350	Tanaka <i>et al.</i> (1978)
38	(<i>Chlamydomonas</i>)	339	Ho and Krogmann (1980)
31	(Charlock)	350	Wood (1977)
27	(<i>Brassica</i>)	365	Gray (1978)
32	(<i>Scenedesmus acutus</i>)	370	Matsuzaki <i>et al.</i> (1975)
33	(<i>Spirulina platensis</i>)	380	Böhme <i>et al.</i> (1980a)
34	Plastocyanin	318	Böhme <i>et al.</i> (1980b)
10.5		370	Katoh <i>et al.</i> (1962)
	Cytochrome <i>b</i> ₅₆₃	—84	Colman <i>et al.</i> (1978)
			Stuart and Wasserman (1975)
		20,9,6,6,6(2) = 40 (four SU)	
	P700 protein (in complex)	18	Lach and Böger (1977b)
		70 (2),	Bengis and Nelson (1977)
		20 (PC-binding)	
	FeS electron acceptor proteins	16, 18	Bengis and Nelson (1977)
	Ferredoxin-NADP+ reductase	34-120	Zanetti and Curri (1980)
		33-36 (monomer)	Sheriff <i>et al.</i> (1980)
	Ferredoxin	—480	Tagawa and Arnon (1962)
			Matsubara <i>et al.</i> (1967)

¹The source of the protein or polypeptide is spinach chloroplasts, unless otherwise indicated.

²The value of the subunit molecular weight of purified cytochrome *b*₅₅₉ has recently been found to be Mr = 10,000 instead of 5.5-6 kD, when measured on SDS-urca-gradient gels (Widger *et al.*, 1982).

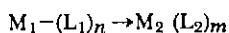

are commonly classified as inner sphere or outer sphere, depending on whether the reaction involves (a) direct transfer of an electron from M_1 to M_2 ; or (b) transfer mediated by one or more bridging ligands $(L_1)_n$ or $(L_2)_m$. In the case of electron transfer to a redox center, M_2 , which is fully coordinated, an inner sphere mechanism would require displacement of a ligand, L_2 , during the time of electron transfer. When these fairly general concepts are applied to electron transfer reactions in solution involving metalloproteins of biological interest, the transfer is generally thought to be by an outer sphere mechanism because of the problem of displacing amino acid residues immediately coordinated to the metal redox center. Transfer by an outer sphere mechanism between such fully liganded redox centers can be more easily described, as in the Marcus theory (see later). In the case of Cyt *c*, where crystal structure and electron transfer mechanisms have been investigated more thoroughly than for any other heme protein (Salemme, 1977; Ferguson-Miller *et al.*, 1978; Adman, 1979), the outer sphere pathway for oxidation and perhaps reduction is thought to have direct access to an edge of the heme exposed at the protein surface (Fig. 1A). Transfer to or from the exposed heme edge could involve a significant barrier if the distance between donor and acceptor and the heme edge were too large. The actual distance over which electron transfer might occur between two heme proteins has been estimated in a model study (Salemme, 1976). The distance of closest interatomic approach between heterocyclic π -bonded atoms of the heme in the respective proteins was found to be approximately 8 Å, several angstroms larger than expected for an outer sphere reaction involving orbital overlap between the reacting species. Such distances between electron donor and acceptor create a barrier to transfer, and in such cases tunneling may contribute to the electron transfer mechanism. *Tunneling* is a phenomenon associated with quantum mechanical properties, whereby the wavelike nature of a particle allows it to pass through a repulsive barrier with an energy larger than its kinetic energy, with a probability sensitively dependent upon barrier width and height.

The two theories of electron transfer that have been applied to problems of electron transfer relevant to photosynthesis are (1) the *Marcus theory* for outer sphere reactions, a classical theory which does not explicitly take into account any quantum mechanical tunneling factors, but for which a central concept is the reorganization of the reacting nuclei and the solvent required for the electron transfer to occur (Marcus, 1965; DeVault, 1980); and (2) the quantum mechanical formulations of

tunneling for electron transfer (Blankenship and Parson, 1979b; Chance *et al.*, 1979; DeVault, 1980).

The Marcus theory can describe solution reactions of photosynthetic redox proteins (Wherland and Pecht, 1978) and quinones (Rich and Bendall, 1980a) fairly successfully when these occur in solution. It may also be useful in describing electron transfer reactions in the photosynthetic membrane in which reactants are mobile as allowed by the fluidity of the local membrane environment. It is unlikely that this theory would be used to accurately describe reactions in the membrane which (1) occur so rapidly that reorganization of the reacting nuclei and surrounding solvent molecules cannot occur; (2) which occur between protein components in the membrane that are widely separated or have large natural barriers to electron transport; or (3) which occur at low temperature where the mobility of the membrane redox components is extremely limited and the quantization of vibrational energy levels is a significant factor. It was, in fact, the temperature independence of cytochrome oxidation at cryogenic temperatures in *Chr. vinosum* that first clearly focused on tunneling as a relevant electron transfer mechanism in photosynthesis (DeVault and Chance, 1966).

In the Marcus theory, the expression for the forward rate constant, k_{12} , of the electron transfer reaction

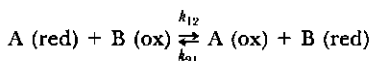

is expressed in terms of the self-exchange rate constants, k_{11} and k_{22} , for

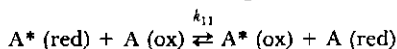

and

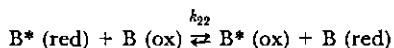

and the equilibrium constant, $K_{\text{eq}} = k_{12}/k_{21}$, for the electron transfer reaction from A to B. The Marcus expression for the forward rate constant in an approximate and simplified form, which appears to describe the kinetics of electron transport between a large number of cytochromes and copper proteins (Wherland and Pecht, 1978) when K_{eq} is not too large, is

$$k_{12} \approx \sqrt{k_{11} k_{22} K_{\text{eq}}}$$

From this approximation, a useful expression can be obtained relating k_{12} and the change of standard or midpoint potential, ΔE° , for a redox reaction.

$$\log k_{12} = \frac{F}{2.3RT} \frac{\Delta E^\circ}{2} + \text{constant},$$

with the first term = ΔE° (mV)/118 for a one electron transfer reaction at 25°C.

B. Specific Examples

The Marcus theory in the preceding approximation has been applied to a set of 13 electron transfer reactions between 6 different groups of iron and copper redox proteins, *Pseudomonas aeruginosa* azurin, azurin from 2 other sources, 2 plastocyanins, *P. aeruginosa* Cyt c_{551} , Cyt c_{553} from the alga *B. filiformis*, and cytochrome *c* (Wherland and Pecht, 1978). Using a best-fit value for the self-exchange rate constant for each of the six groups of proteins, the calculated forward rate constant for the 13 redox reactions between different donors and acceptors was found to agree with measured values. It was concluded that within this group of redox proteins, derived from algae and nonphotosynthetic bacteria, that there was in most cases no kinetic selectivity operating in the electron transfer reactions. An important exception was parsley Cyt *f*, which was found to react very selectively with plant plastocyanin as compared to bacterial azurin.

The Marcus theory has also been found to fit data for the rate of reduction of cytochrome *c* by a series of substituted benzoquinols. The ΔE° values are calculated for the transfer from the anionic quinol to Cyt *c* (Rich and Bendall, 1980a). When the data are plotted in this way, the slope of $\log k_{12}$ versus ΔE° is approximately $(118 \text{ mV})^{-1}$. The ability of the Marcus theory prediction to fit these data has been used to support a possible physiological function for the anionic quinol–semiquinone couple ($\text{QH}^-/\text{QH}^\cdot$) in one electron transfer reaction to cytochromes *b*, *c*₁, or *f*, or the high potential FeS protein in chloroplast and mitochondrial membranes (Rich and Bendall, 1980a).

An application of the tunneling equation to the problem of electron transfer from the rapidly (psec) reduced electron acceptor, I, in reaction centers to the quinone acceptor complex, $\text{I}^- \cdot \text{Q}^- \cdot \text{Fe}^{2+} \rightarrow \text{I} \cdot \text{Q}^{2-} \cdot \text{Fe}^{2+}$, utilized the relation between the tunneling matrix elements, $|T_{12}|$, and magnetic exchange leading to ESR signal splitting when the donor and acceptor contain unpaired electrons (Okamura *et al.*, 1979). (For a background on primary reactions and reaction centers, see Wraight, Chapter 2; Okamura *et al.*, Chapter 5; and Parson and Ke, Chapter 8, this volume.) $|T_{12}|$ could then be evaluated in terms of the magnetic coupling constant, *J*, determined as 60 gauss from the measured doublet splitting for the state $\text{I}^+ \text{Q}^\cdot$. Given knowledge of the reorganizational energy

accompanying the electron transfer, it would be possible to evaluate the matrix element $|T_{12}|$ characteristic of the tunneling process.

Another experimental situation in photosynthesis that has been associated with the existence of electron tunneling is the observation of electron transfer reactions at cryogenic temperatures. The initial suggestion for operation of a tunneling mechanism in photosynthetic electron transport came from experiments on the light-induced cytochrome oxidation in the purple photosynthetic bacterium *Chromatium* as a function of temperature (DeVault and Chance, 1966). At room temperature the half-time for oxidation was 2 μ sec, and the activation energy over an extended temperature range was 3.3 kcal/mole. The rate was measured as the temperature was lowered to cryogenic levels and the half-time at 120°K increased to 2.3 msec. The observation that the rate decreased very little below 120°K implied the existence of a tunneling mechanism below this temperature. There are now many other examples of electron transfer reactions at low temperatures showing a very small dependence of rate on temperature (DeVault, 1980).

Whether the physicochemical mechanism of electron transfer can be described by classical theories useful for solution reactions or theories involving quantum-mechanical considerations, there is much biochemical evidence to indicate that, at least in Cyt *c*, an exposed heme edge of the cytochrome provides the route for oxidation and possibly reduction, as well. A reason for involving the heme edge of Cyt *c* in the pathway and mechanism for oxidation and/or reduction is that a positive charge distribution around the exposed edge appears to be an invariant structural feature in *c*-type cytochromes from several sources. This charge distribution occurs in eukaryotic Cyt *c*, as well in the Cyt *c*₂ from the photosynthetic bacterium *Rs. rubrum* and Cyt *c*₅₅₀ from *Micrococcus denitrificans* (Salemme, 1977). The region around residue positions 5 and 8 over the exposed edge is positively charged in every cytochrome, although there is some variation in the exact positions of the residues. Residues 12–13 are always positive except in Cyt *c*₂ from the photosynthetic bacterium *Rp. sphaeroides*. Residue 27 is lysine in all prokaryotes, and in all eukaryotes except the algae *Euglena* and *Crithidia*. Residues 72–73 are always positive except in two Cyt *c*₂'s. Residue 79 is always a lysine except for a glycine substitution in *c*₂ of *Rp. capsulata*. Residues 83–88 always have at least one positive charge. There is at least one negative charge around positions 90–93 (Salemme, 1977; Fig. 14).

Besides the invariance of the positive charges around the exposed heme edge, the other reason for believing that these charges are important in the electron transfer mechanism is based on a series of chemical modification studies involving the reaction of mammalian Cyt *c* and its oxidase (Ferguson-Miller *et al.*, 1978) and reductase (Speck *et al.*, 1979).

The interaction of Cyt *c* with oxidase appears to occur through an ionic mechanism since mitochondrial Cyt *c* is strongly cationic with a $pI \approx 10$, and the reaction between Cyt *c* and the oxidase is sensitive to ionic strength.

Selective and specific chemical modification of Cyt *c* lysines results in loss of oxidase function. Modification of other residues such as methionine or tyrosine was once thought to provide specific information, but it now appears that these treatments also cause damage to the Cyt as judged by loss of the 695 nm band (Dickerson and Timkovich, 1975). The reagent CDNP (4-chloro-3,5-dinitrobenzoic acid) can selectively modify individual lysines centered around the beta carbon of phenylalanine 82, with the resulting inhibition of the binding to cytochrome oxidase correlating very well with the order of elution from a carboxymethyl cellulose column (Brautigan *et al.*, 1978a,b; Ferguson-Miller *et al.*, 1978). The role of these lysines in binding to the oxidase and reductase is further illustrated by the ability of the oxidase (Rieder and Bosshard, 1978a), *b-c*₁ reductase (Rieder and Bosshard, 1978b), and Cyt *c* peroxidase (Pettigrew, 1978) to differentially shield these lysines from labeling. It has been inferred from the preceding material that electron transfer reactions of Cyt *c* in solution occur through a mechanism involving the exposed heme edge of these cytochromes, with many of the basic residues around the heme providing ionic attraction to the acceptor and/or donor redox protein. Similar conclusions have been reached for Cyt *c*₂ of the bacteria (Wood *et al.*, 1977). A variation of this conceptual framework occurs in *Euglena* Cyt *c*₅₅₂ where, although the electron transfer appears to involve the exposed heme edge, reduction and oxidation take place at a negatively charged site on the surface of Cyt *c*₅₅₂ (Wood and Cusanovich, 1975). A very different kind of protein-protein interaction mechanism, involving nonpolar and nonelectrostatic interactions, appears to govern the electron transfer from bacterial cytochromes *c*₂ to bacterial high-potential iron proteins (Cusanovich and Mizrahi, 1979).

III. Properties of Quinones

A. Quinone Species

Three main types of isoprenoid quinones are employed in photosynthetic electron transport, ubiquinone (UQ-7 and UQ-10) and menaquinone (MQ-7) in the bacteria, and plastoquinone (PQ-9) in chloroplasts, algae, and cyanobacteria. The content of PQ-9 in chloroplasts has been estimated to be 40 molecules per reaction center (Crane, 1965). The content of UQ-10 in photosynthetically grown purple nonsulfur

bacteria and of UQ-7 and MQ-7 in *Chromatium vinosum* has been estimated to be 25–40, 15, and 6 molecules per reaction center (data summarized in Hauska and Hurt, 1981).

The values of E_{m7} in situ are 40–65 mV (Urban and Klingenberg, 1969) and 90 mV (Takamiya and Dutton, 1979), respectively, for ubiquinone in mitochondria and chromatophores, and 80 mV (Okayama, 1976) or 120 mV (Golbeck and Kok, 1979), for plastoquinone in chloroplasts. In all cases the value of E_m varied by $(-2.3 RT/F \cdot \text{pH} = -59 \cdot \text{pH} \text{ mV})$ over the physiological pH range.

B. Electron and Proton Transfer Reactions in Solution

The relevant redox and protonation reactions of quinone, Q, are



characterized by midpoint potentials E_{m1} , E_{m2} , and E_m , respectively.

The reaction among the quinone species usually discussed is $Q + QH_2 \rightarrow 2QH$, characterized by the semiquinone formation (or stability) constant:

$$K_s = \frac{(QH)^2}{(Q)(QH_2)} \quad (4)$$

with quantities in parentheses equal to concentrations when measurements are made under dilute conditions (Clark, 1960).*

The acid–base equilibria for the quinol (QH_2 and QH^-) and semiquinone (QH) species, with the measured dissociation constants at 25°C for duroquinol and durosemiquinone measured in aqueous solution, except where indicated, are:

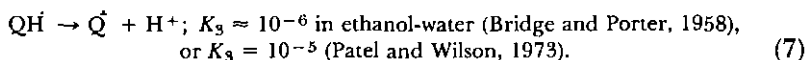
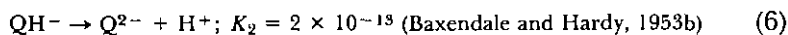
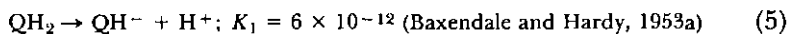

Rich and Bendall (1979, 1980a) have recently presented a compilation of pK and midpoint potential data for a number of substituted quinones, as well as a useful graphical description of the pH dependence of the midpoint potential of the various redox species of menadiol.

*Note that $K_s = 1/K_d$, where K_d is the dismutation constant.

C. Reduction of Cytochrome *c* by \dot{Q} and QH^- in Solution

The reducing species, which have been identified in the literature, are the quinols QH_2 , QH^- , and the semiquinones $QH\dot{}$, \dot{Q} . The *in vitro* reduction of Cyt *c* by hydroquinone proceeds primarily through the anionic quinol (QH^-) or anionic semiquinone (\dot{Q}) as the direct reductant of ferricytochrome *c* in solution. Reduction of Cyt *c* by *p*-benzoquinol occurs through \dot{Q} (Yamazaki and Ohnishi, 1966; Rich and Bendall, 1980a) and QH^- (Rich and Bendall, 1980a). The reduction of Cyt *c* by catechol (Toppen, 1976) and menadiol (Rich and Bendall, 1979) occurs through QH^- , with the reduction by catechol thought to be trimolecular, involving two Cyt *c* molecules. The second-order rate constant for reduction of Cyt *c* by anionic menaquinol, MQH^- , was calculated to be $\sim 1.1 \times 10^6 M^{-1} sec^{-1}$ at 25°C. The second-order rate constant for the reduction of Cyt *c* by a series of substituted *p*-benzoquinols has also been studied as a function of the midpoint potential of the reductant (Rich and Bendall, 1980a). The rate constant was found to be proportional to the square root of the equilibrium constant between QH^- and Cyt *c*, implying that these electron transfer reactions can be described by the Marcus theory.

D. Stability and Relative Reducing Strength of the Semiquinone Species

The semiquinone species have received much attention because of the discussion of Q-loop models of proton translocation initiated by Mitchell (1976).

The reducing strength in the semiquinone and quinol participating in Eqs. (1) and (2) described earlier in Section III, B depends on the stability of the semiquinone species with respect to dismutation. If the dismutation reaction, $2QH\dot{}$ \rightarrow $Q + QH_2$, is written as the sum of Eqs. (1) (going right to left) and (2), then it can be seen that the relative strength of $QH\dot{}$ as a reductant compared to QH_2 depends on the stability constant, K_s , expressed in Eq. (4). If K_s is small, then it follows from Eq. (1) for $Q \rightleftharpoons QH\dot{}$ that $QH\dot{}$ \rightarrow Q tends to be favored, or from Eq. (2) for $QH\dot{}$ \rightleftharpoons QH_2 that the equilibrium would tend to lie in favor of $QH\dot{}$ \rightarrow QH_2 . These two effects would define $QH\dot{}$ as a reductant of greater strength than QH_2 . Quantitatively, the difference in midpoint potentials of Eqs. (1) and (2) is

$$E_{m1} - E_{m2} = 2.3 \frac{RT}{F} \log_{10} K_s, \quad (8)$$

so that if K_s is less than 1, $E_{m1} < E_{m2}$ and the semiquinone is a stronger reductant than QH_2 . The midpoint potentials, E_{m1} and E_{m2} , of the two semiquinone reactions are split symmetrically about the midpoint, E_m , for the quinone-quinol Eq. (4),

$$E_m = (E_{m1} + E_{m2})/2 \text{ (Clark, 1960).} \quad (9)$$

K_s was estimated to be 1.3 for durosemiquinone (DQ) at pH = 13 (Baxendale and Hardy, 1953b). From the values of the pK's given in Eqs. (5)–(7) (Section III,B), it was estimated that the K_s for the protonated semiquinone (DQH) is 10^{-12} , or perhaps 10^{-10} in a lipid environment (Mitchell, 1976). A K_s of 10^{-10} can be seen from Eqs. (8) and (9) to give a splitting of ± 300 mV about the midpoint E_m (Mitchell, 1976).

The stability constants of the semiquinone associated with the mitochondrial succinate dehydrogenase and Cyt *b-c*₁ complex have been estimated to be 10^{-2} – 10^{-3} and 5×10^{-2} , respectively (Ohnishi and Trumppower, 1980) or 10^{-5} in submitochondrial particles (de Vries *et al.*, 1981). Redox titrations in chromatophores of the iron-quinone ESR signal associated with the two-electron 'gate' of *Rp. viridis* (Rutherford and Evans, 1979), and *Rp. sphaeroides* (Rutherford and Evans, 1980), and of the binary pattern in rate of oxidation in Q_A in chloroplasts (J. Bowes and A. R. Crofts, unpublished observations) indicate that the value of K_s is in the range 1–20, much larger than indicated by the original estimates of Mitchell (1976). Furthermore, the primary quinone acceptors of PSII and the bacterial reaction center form stable semiquinones upon reduction, and much lower potentials are required for complete reduction to the quinol form (Rutherford and Evans, 1979). These considerations also imply that the effective values of K_s for the semiquinone species involved in fast electron transfer reactions in the quinone primary acceptor complex are many orders of magnitude larger than the original estimate of Mitchell (1976). This evidence indicates that these reactions involve quinones, the semiquinone species of which are bound in a proteinaceous environment that markedly changes their properties with respect to those of quinones in solution (also see Section IV,B–E).

E. Spectroscopic Properties of Ubi- and Plastosemiquinone

The presence of quinone radical can in some cases be detected in the $g = 2$ region by ESR spectroscopy. However, in many cases the spectrum is broadened and shifted by interaction with neighboring groups. The distinction between the anionic and neutral quinone radical can be made spectrophotometrically (Bensasson and Land, 1973). The anionic radi-

cals of plastoquinone and ubiquinone show absorbance maxima in the near UV at 320 nm and in the blue region of the spectrum at 440–450 nm, with molar extinction coefficients of about 10,000 and 6000, respectively. The neutral form of the plastoquinone radical has absorbance maxima at 265 nm, 295 nm, and a peak of small amplitude at 415 nm, whereas the ubiquinone neutral radical has broad maxima at 280 and 430 nm. Thus, it is possible to distinguish the different forms of the semiquinone radicals spectrophotometrically. The plastoquinone difference spectra ($PQ^{\cdot-} - PQ$) in the near UV (300–350 nm) region of the spectrum are similar to light-minus-dark spectra obtained for the primary acceptor of PSII (Stiehl and Witt, 1969; van Gorkom, 1974; Melis and Duysens, 1979). Ubiquinone difference ($UQ^{\cdot-} - UQ$) spectra in the blue region of the spectrum near 450 nm are also similar to those obtained for the primary quinone acceptor of the bacteria (Vermeglio, 1977; Wraight, 1977).

F. Quinone Mobility in Membranes

The H^+ -translocating loops proposed by Mitchell (1966) consist of alternately directed hydrogen and electron carriers in energy-transducing membranes. Ubiquinone and plastoquinone are obvious candidates for hydrogen carriers able to span the membrane because they are present in high concentrations. The ready extraction of quinone into organic solvents suggests that a large amount of the ubi- and plastoquinone in the membrane is loosely bound and diffusible in the membrane. The basis of transmembrane diffusion or shuttling of these quinones has, however, not been described or proven.

It has been argued that a transmembrane shuttle role for ubiquinone is unlikely because of the large size and relative rigidity of the unsaturated isoprenoid side chain (Trumpower and Katki, 1979). The problem of geometrical or steric constraints on the motion of ubiquinone can be seen from the fact that the extended 50 carbon isoprenoid side chain of UQ-10 is 48 Å and the entire molecule would be 56 Å. This length is somewhat greater than the thickness of the insulating phase of a bilayer membrane, which would be approximately 40–50 Å. The orientation of the quinone molecules with respect to the phospholipid side chains is not known. From the preceding dimensions, a rigid vertical orientation seems unlikely.

In spite of the preceding uncertainty, there is now an experimental basis for considering the existence of transmembrane quinone-mediated hydrogen transfer. Incorporation of ubiquinone and plastoquinone into artificial membrane vesicles made of soybean lecithin greatly stimulated

the reduction of encapsulated ferricyanide by externally added reductant (Futami and Hauska, 1979; Futami *et al.*, 1979). The role of the isoprenoid chain in the transmembrane redox function was not completely clear in these studies, although the short chain UQ-1 and UQ-2 compounds along with the simple quinones TMQ, DQ, and MDQ without side chains, were the least effective quinones. UQ-3 through UQ-9 appeared similar in efficiency of redox function, and UQ-10, the natural ubiquinone, slightly less effective. Plastoquinone was much more effective as a redox catalyst in these experiments than the short- or zero-chain quinones, but the rate of ferricyanide reduction was about 5 times slower with PQ than with UQ-3 through UQ-10, assuming an equal extent of incorporation of all these quinones into the vesicle membrane. In a reconstituted system containing bacterial reaction centers, ubiquinone-10 was able to catalyze a proton pump linked to cyclic electron flow around the reaction center (Crofts *et al.*, 1977a).

The transbilayer motion of the headgroup of ubiquinone in vesicles made of a single perdeuterated phospholipid, dimyristoylphosphatidylcholine (DMPC) with 14 carbon fatty acid chains, has been studied through the effect of chemical shift reagents on the ubiquinone headgroup methoxy proton (^1H) resonance (NMR), using a quinone:lipid ratio of 3 mol.%, only slightly higher than the quinone concentration estimated to exist in the lipid of the inner mitochondrial membrane (Kingsley and Feigenson, 1981). The motion of the quinone ring, judged from the line width of the methoxy ($-\text{OCH}_3$) proton resonances (see Fig. 1C for ring structure) decreased, whereas the depth of the quinone:quinol ring relative to the membrane surface in large vesicles increased, with increasing isoprenoid chain length. The ring of reduced ubiquinol was found to be closer to the membrane surface, on the average, than that of ubiquinone. The existence of a fairly rapid transmembrane exchange was inferred from the presence of a single $-\text{OCH}_3$ resonance in the presence of shift reagents, implying that the magnetic environments at the inner and outer halves of the bilayer are averaged by transbilayer motion. The *minimum* exchange rates were found to range from 23 sec^{-1} for UQ-10 to 215 sec^{-1} for UQ-1. These rates for the longer chain ubiquinones are similar to turnover rates calculated for the dithionite-ferricyanide reaction in the quinone-reconstituted system of Futami *et al.*, (1979), but the exchange rates for the short chain quinones are much faster than the turnover rates obtained from the electron transfer experiments. The exchange rates may be compared with the turnover of photosynthesis under conditions of maximal flux ($100\text{--}300 \text{ sec}^{-1}$), bearing in mind the high stoichiometry of quinones per chain. The NMR experiments on UQ motion in DMPC vesicles imply that the

transmembrane headgroup motion is kinetically competent although the quinone environment and interaction with lipid in the very short chain DMPC vesicles is not the same as in the longer chain DPPC vesicles, and may not be physiological (Ulrich *et al.*, 1982).

Diffusive motion of plastoquinone in directions parallel to the plane of the membrane has been discussed recently in the context of the hypothesis that PSII and PSI are spatially separated, with PSII mostly confined to the appressed grana membranes and PSI localized in the exposed membrane region consisting of the grana end membranes and the stromal membranes (Anderson, 1981; see I. Ohad and G. Drews, Chapter 5, in Govindjee, Volume II (1982); also see Kaplan and Arntzen, Chapter 3 of this volume). It was proposed that plastoquinone is the mobile redox carrier that communicates, through two dimensional diffusive motion, between widely separated lipoprotein complexes of PSII and PSI. An order of magnitude calculation made by Anderson (1981) was that the distance over which plastoquinone could migrate in 1 msec was ~ 50 nm if the plastoquinone was assumed to have a lateral diffusion coefficient similar ($\sim 10^{-8}$ /cm²/sec) to those which have been determined by spin label, fluorescence probe studies, and fluorescence photobleaching for phospholipids. It is again not clear whether the lateral motion of ubi- and plastoquinone would be impeded, relative to that of a conventional phospholipid, by the long isoprenoid chain. In *Rp. sphaeroides* the diffusion of UQH₂ from its site of reduction at the reaction center to its site of utilization at the UQH₂-Cyt c₂ oxidoreductase complex takes ≈ 1 msec (Baccarini-Melandri *et al.*, 1982). Assuming the proteins to be uniformly distributed, this indicates a diffusion coefficient of $\approx 10^{-9}$ /cm²/sec.

IV. Primary and Secondary Quinone Acceptors

The term *primary acceptors* has taken on a certain ambiguity with the development of picosecond techniques, and the characterization of the initial photochemical processes. In all the photochemical reaction centers so far studied, electron acceptors that are reduced and oxidized in the time domain shorter than the fluorescence lifetime have been characterized as intermediates in the electron transfer from the primary donor to the first stable acceptor. These intermediate acceptors are certainly primary in the temporal and mechanistic senses, but the concentrations of the reduced species under normal operating conditions is never significant. In this chapter, we will use the term *primary acceptor* to refer to the first acceptor that is stable, with a rate of reoxidation that is slow compared with the lifetime of fluorescence.

A. Methods for the Measurement of the Electron Transfer Properties of the Primary Acceptor

Four main methods are available for measuring the reactions of the primary quinone acceptor, each of which has its drawbacks.

1. The most direct measurements are by spectrophotometry using the difference spectra and extinction coefficients of the different quinone species mentioned earlier. The disadvantages of this method are (a) the difficulty of making absorbance measurements in the region of strong background absorbance by chlorophylls (Chl) and carotenoids; (b) the presence of other absorbance changes whose spectra overlap those of the quinones; (c) the semiquinone anions of the primary and secondary quinone acceptors Q_A and Q_B (also referred as Q_I and Q_{II} ; discussed further in IV,B-D) have similar spectra, so that the electron transfer reaction $Q_A^{\dot{-}} Q_B \rightarrow Q_A Q_B^{\dot{-}}$ has no marked absorbance change in the blue or near UV region.

2. Although the semiquinone species have similar spectra, they appear to interact differently with neighboring pigment molecules, in which the presence of a local charged group induces a spectral shift. This gives rise to a difference spectrum between the states $Q_A^{\dot{-}} Q_B$ and $Q_A Q_B^{\dot{-}}$, which can be used both to measure one of the redox states and to measure the electron transfer reaction. In chloroplasts, the red shift at 550 nm (C550) (Knaff and Arnon, 1969b) and in *Rp. sphaeroides*, the red shift of the bacteriopheophytin Bph bands (Vermeiglio *et al.*, 1980b), has been used as an indicator of these changes.

3. The electron transfer rate from the primary acceptor can be measured indirectly by following the rate of regeneration of "open" photochemical traps. This method depends on (a) a method for measuring photochemical turnover, and on (b) a rapid rereduction of the primary donor, so that the opening of the traps is determined by electron transfer from the primary stable acceptor. This method has been used successfully in *Chromatium* and *Rp. viridis* and in measurements of PSII turnover. In the bacteria, the photochemical turnover can be measured directly by the absorbance change of the primary donor or more easily by those of the Cyts that act as secondary donors. In chloroplasts or algae, the turnover has been assayed by measuring the yield of oxygen (or of some artificial donor) in a suitable flash regime. In chloroplasts and in *Rp. sphaeroides* or *Rp. capsulata*, the photochemical turnover can be assayed by the fast phase of the electrochromic carotenoid change.

4. Fluorescence yield of Chl can be used as an indicator of an acceptor's redox state, since if the reaction center is "closed" by reducing the acceptor, energy transfer to the reaction center cannot occur and energy

will remain in the antenna complex until it is lost as fluorescence or heat. The absolute fluorescence yield of chloroplasts measured with a low intensity excitation beam is approximately a few percent, corresponding to a mean lifetime of fluorescence in a medium of relatively high ionic strength of 0.3–0.5 nsec (Moya *et al.*, 1977; Sauer and Brewington, 1978). In strong actinic light, these values increase to give a mean lifetime of 1.4 nsec (Moya *et al.*, 1977). The light-induced increase of fluorescence yield has been used to study redox properties of the primary acceptor (Butler, 1962; Duysens and Sweers, 1963). It was hypothesized that the increase in fluorescence yield was controlled in the manner described earlier by compound Q (quencher of fluorescence), here called Q_A . The antagonistic effect of PSII and PSI in being able to, respectively, reduce and oxidize the Q_A , could be demonstrated (Butler, 1962; also see Govindjee *et al.*, 1960).

The disadvantages of this method arise from the fact that many other phenomena apart from the redox state of Q_A contribute to changes in the fluorescence yield. Among these are

1. In PSII centers containing either the oxidized primary donor $P680^+$ (Butler, 1972; den Haan *et al.*, 1974) or the reduced intermediate acceptor Ph^+ (Klimov *et al.*, 1977), a quenching of fluorescence is observed. The mechanism of the quenching is not yet established. In measurements of the kinetics of electron flow from Q_A^+ , the quenching interferes for a period depending on the lifetime of $P680^+$, typically <50 μ sec in normal chloroplasts or algae.

2. In quenching by the triplet state, excess quanta absorbed in the pigment bed are lost by a mechanism in which excess Chl singlets are converted to triplets that transfer their energy to form carotenoid triplets, which in turn dissipate their energy as heat. This mechanism protects the photosynthetic apparatus from photo-oxidative damage. The energy dump or "valve effect" occurs over a period of several microseconds and is fastest in the presence of oxygen (see Witt, 1979, for a review). The fraction of excitons lost by the valve effect depends on the intensity of the exciting light, being minimal at levels subsaturating for the photochemistry, but showing no saturation. Since this fraction of quanta is not available for fluorescence, the yield of fluorescence is lowered during the dumping process by an amount dependent on the light intensity. The effect interferes with measurements dependent on the quenching effects of $P680^+$ or of the "open" trap, but it is significant only during intense illumination and for a few μ sec afterwards.

3. Over time scales longer than those of the two previous phenomena, various mechanisms concerned with the distribution of quanta between the photosystems come into play. These include surface charge

effects, redistribution of molecular complexes within the plane of the membrane, and phosphorylation by a light dependent, redox-controlled kinase of membrane proteins including the light-harvesting Chl a : b protein complex (LHCP), which affects energy distribution (see, e.g., Bennett *et al.*, 1980). These phenomena contribute to the complex kinetics of fluorescence induction curves (see Papageorgiou, 1975) because the redistribution of ions and the phosphorylation reactions occur on the time scale of the development of the proton gradient and the reduction of the plastoquinone pool.

4. Changes in fluorescence yield are specifically associated with the onset of the proton gradient, giving rise to the "fluorescence lowering" phenomenon (Murata and Sugahara, 1969; Wraight and Crofts, 1971; Briantais *et al.*, 1979).

5. There is nonlinearity in the relation between fluorescence yield and concentration of reduced primary acceptor (Joliot and Joliot, 1964; Joliot *et al.*, 1973; van Gorkom and Pulles, 1978). This is usually attributed to the fact that the LHC complexes are able to pass excitons to more than one reaction center. As a consequence, the probability of an exciton finding a trap is high until a substantial fraction of traps is closed, so that the increase in fluorescence yield lags behind the closure of traps.

6. The interpretation of fluorescence changes is further complicated by the probability that PSII centers may be heterogeneous with respect to primary quinone acceptors, their coupling to the intermediate electron transfer chain, and their distribution between stroma and grana (see Section IV,C).

In spite of these problems, it has been possible to use the increase of fluorescence yield as an indicator of the redox state of the primary acceptor Q_A in chromatophores and chloroplasts and to titrate the mid-point potential of Q_A by measuring the change of fluorescence yield as a function of ambient redox potential in chloroplasts (Cramer and Butler, 1969; Knaff, 1975; Horton and Croze, 1979) and bacteria (Cramer, 1969; Reed *et al.*, 1969). The chloroplast data are discussed in Section IV,C. The decrease in fluorescence yield on reopening of the closed PSII traps has also been used to measure the rate of electron transfer out of Q_A^* (Forbush and Kok, 1968; Joliot and Kok, 1975; Bowes and Crofts, 1980).

B. Properties of the Primary Acceptor Complex of the Bacteria

The acceptor complex in the bacteria is now known to consist of two quinone molecules (Q_A and Q_B) and an iron atom. The quinone species

is UQ-10 in *Rp. sphaeroides* and *Rs. rubrum* and a menaquinone in *Chr. vinosum* (Feher and Okamura, 1978). The reduction of Q_A occurs very rapidly, in 10^{-10} sec (Kaufmann *et al.*, 1975; Rockley *et al.*, 1975), whereas transfer from Q_A^* to Q_B has a $t_{1/2} \approx 100$ μ sec at pH = 7.5 (Vermeglio and Clayton, 1977; Blankenship and Parson, 1979a) in isolated reaction centers, and ~ 35 μ sec in chromatophores (Bowyer *et al.*, 1979). The removal of Q_B , which is relatively loosely bound, does not affect the primary photochemistry (Okamura *et al.*, 1975). The E_m measured at pH values above the pK for dissociation of QH^+ to Q^* is thought to reflect the operating potential in the membrane, because the electron transfer is much more rapid than proton transfer. The operating midpoint potentials of the reduced acceptor in *Chr. vinosum*, *Rs. rubrum*, and *Rp. sphaeroides* were found to be -160 mV, -200 mV, and -180 mV, and the pK values were 8, 9, and 10, respectively (Prince and Dutton, 1976). The temperature dependence of the midpoint potential in *Chr. vinosum* indicates that a large decrease of entropy (71 cal mole $^{-1}$ deg $^{-1}$) accompanies the reduction of Q_A (Case and Parson, 1971).

The Q_A -Fe- Q_B quinone acceptor complex of *Rp. sphaeroides* reaction center acts as a two electron gating system, in that transfer of one electron to the complex results in formation of a stable semiquinone anion ($Q_B^{\dot{-}}$) which disappears with a $t_{1/2} = 10$ -200 μ sec, depending on pH and bacterial species (Blankenship and Parson, 1979a), upon reduction by a second electron, and upon transfer of two protons (Vermeglio, 1977; Wraight, 1977, 1979). Detailed properties of this gating system are discussed by Wraight (1981; also see Chapter 2, this volume). See Section IV,D for a detailed discussion of the analogous gating system in chloroplasts and algae. A diagram of the bacterial acceptor complex is shown in Fig. 3.

The role of the high spin ($S = 2$) ferrous (Fe^{2+}) iron in the quinone acceptor complex is not clear. It appears not to be directly involved in the primary photochemistry since the latter is not affected by removal of most of this iron (Loach and Hall, 1972), and Mössbauer studies show that the valence and magnetic moment (~ 5.35 Bohr magnetons) do not change when reaction centers are chemically reduced (Debrunner *et al.*, 1975; Feher and Okamura, 1978; Butler *et al.*, 1980). It has been proposed that this iron might facilitate electron transfer between Q_A and Q_B (Okamura *et al.*, 1975; Blankenship and Parson, 1979a), although the chemical nature of the Fe environment and of the Fe bonding is not known. The Fe is not heme iron, nor is it bonded to sulfur. The magnitude of the exchange interaction between Fe^{2+} and the quinone spin has been found to be small enough so that it is thought to be unlikely that quinone is a ligand of the Fe (Butler *et al.*, 1980). Even though the Fe does not affect photochemistry, it does influence the ESR spectrum

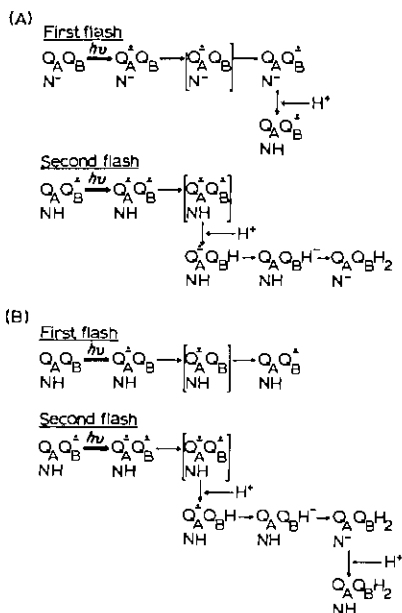

FIG. 3. A scheme for electron transfer and proton binding in the quinone acceptor complex of photosynthetic reaction centers. (A) At high pH the proton taken up on the first flash is not initially bound to a semiquinone but to a nonchromophoric group (N^-/NH) in the reaction center complex. After the second flash, the disproportionation of the two semiquinones is rate limited by the uptake of a single H^+ . This is the first proton bound by the quinone (Q_B). The subsequent electron transfer produces fully reduced quinol, which can obtain its second proton from the group NH , protonated on the first flash. (B) At low pH (< 7) it has not been possible to kinetically distinguish the two protons taken up on the second flash, but the model derived at high pH can be readily extended to low pH. In this case, the second proton bound regenerates NH . The two protons would indeed be kinetically indistinguishable if the intervening steps, including electron transfer, were sufficiently fast. The scheme and figure legend are kindly provided by C. A. Wraight (see Wraight, 1979, 1981).

of the acceptor since magnetic energies and energy splittings are small. Loss of iron from quinone acceptor complex results in elimination of the light-induced $g = 1.82$ ESR signal and the appearance of a $g = 2.0045$ signal characteristic of a quinone anion radical (Okamura *et al.*, 1975). However loss of iron is consequent upon removal of the H (heavy) subunit (see Okamura *et al.*, Chapter 5, this volume) of the reaction center, and evidence now suggests that the H subunit rather than iron is required for electron transfer to Q_B (Debus *et al.*, 1981). The binding site for Q_A has been shown to be on the M (medium) subunit (Fehér and Okamura, 1978); possibly the H subunit serves several functions, both catalytic and structural, providing stabilization for the iron and the binding site for Q_B .

C. Primary Quinone Electron Acceptor of the Photosystem II

The electron acceptors of PSII bear some similarity to those of the bacterial system in that a quinone, or semiquinone, acceptor can be defined by titration of fluorescence yield in a potential region fairly close to that measured in the bacterial system. Titration of the fluorescence

yield giving a midpoint near 0 volts ambient potential has been observed in a number of laboratories (Cramer and Butler, 1969; Erixon and Butler, 1971; Knaff, 1975; Ke *et al.*, 1976; Horton and Croze, 1979; Malkin and Barber, 1979; Baker and Horton, 1980) with the majority of the measurements indicating a quenching component with an E_{m7} near -20 mV. A midpoint potential somewhat more positive than 0 volts was found in titrations of particles of a PSI-deficient mutant of the green alga *Scenedesmus*, in titrations of a slow component of the chloroplast light-induced electrochromic shift (Malkin, 1978) and in a titration of the fluorescence yield (Malkin and Barber, 1979). The other similarity between the acceptor system of the chloroplast PSII and that of the bacteria is that a much lower potential acceptor, suggested to be a pheophytin (Klimov *et al.*, 1977) with an $E_m \approx -600$ mV (Klimov *et al.*, 1980; Rutherford *et al.*, 1981) has been found to be rapidly reduced (Shuvalov *et al.*, 1980) in chloroplast particles enriched in PSII (also see Parson and Ke, Chapter 8, this volume). As in the bacterial system, the acceptor defined by titrations of fluorescence yield is a quinone-semiquinone couple, in this case, plastoquinone-semiquinone (Stiehl and Witt, 1969; van Gorkom, 1974; Pulles *et al.*, 1976). Consistent with this identification based on spectrophotometric observation of the light-induced formation of the plastoquinone anion radical at 320 nm, the midpoint potential of the ~ 0 volt quenching component Q_A ($\equiv Q_1$) has been found in most studies to show a pH dependence in the range of 6–8 similar to that expected for a component undergoing a $1e-/1H^+$ oxidation-reduction. Formation of the plastoquinone anion radical also correlates (van Gorkom, 1974) with another spectral change at 550 nm (C550) associated with reduction of the electron acceptor complex of PSII (Knaff and Arnon, 1969b). This pH dependence of the E_m of Q_A extends only to 8.9, above which the E_m was -130 ± 20 mV and independent of pH (Knaff, 1975). The pH value of 8.9 would then presumably correspond to the pK of the neutral semiquinone form of Q_A . The operating midpoint potential of Q_A in the light would then be -130 mV, because the kinetically competent redox reaction of Q_A as a primary electron acceptor would be $Q^{\cdot-}/Q$ and not $QH^{\cdot-}/Q$. These arguments have also been made for the "primary" electron acceptor of *Rp. sphaeroides* chromatophores (Prince and Dutton, 1976). The redox reaction of the primary acceptor plastoquinone-plastoquinone couple titrated in the dark would be $PQH^{\cdot-} \rightarrow PQ + H^+ + e^-$ or $PQ^{\cdot-} \rightarrow PQ + e^-$, dependent upon pH. One complication in this interpretation is the pK of $PQH^{\cdot-}$, which in solution has a value around 5.0 (Bendall, 1977; also see Section III,B). This does not coincide with the conclusion that the pK of the reduced form of $QH^{\cdot-}$ is 8.9. However, as noted earlier, the proper-

the quinones are known to be substantially modified by their binding proteins, and it seems reasonable to regard this difference in pK as reflecting such a modification. The difference between the operating donor and quinone acceptor potentials in PSII would then be ≈ 1.1 – 1.3 V. The difference between donor and acceptor midpoint potentials in the bacteria is ≈ 0.6 – 0.65 V. See Chapter 8 by Parson and Ke of this volume for a discussion of the electron transfer events preceding quinone reduction in PSII and the primary acceptor reactions of PSI.

An important difference in the properties of the primary quinone acceptor system of the plant PSII, compared to that of the bacteria, is the presence of a second acceptor component with an $E_{m7} \approx -250$ – -300 mV seen in titrations of the fluorescence yield of PSII (Cramer and Butler, 1969; Ke *et al.*, 1976; Golbeck and Kok, 1979; Horton and Croze, 1979; Malkin and Barber, 1979; Baker and Horton, 1980). This lower potential quenching component has been called Q_L ($E_{m7} = -250$ – -300 mV), and that measured at higher potential ($E_{m7} \approx -20$ mV) and described earlier is given the notation Q_H . The notation Q_H and Q_L for chloroplasts refers to two redox components associated with the primary quinone acceptor Q_A . The notation Q_1 and Q_2 also refers to heterogeneous properties of Q_A (Joliot and Joliot, 1979). It has been proposed that Q_L might be a pheophytin, but this appears not to be correct because (a) the recently measured E_m of pheophytin at about -600 mV (Klimov *et al.*, 1980; Rutherford *et al.*, 1981) is much more negative than that of Q_L , and (b) in addition, the E_m of Q_L is pH-dependent (Cramer and Butler, 1969; Horton and Croze, 1979). This would be consistent with Q_L also belonging to a plastoquinone–semiquinone couple (Cramer and Butler, 1969; Melis, 1978; Melis and Duysens, 1979). A possible correlation has also been noted between the relative amount of Q_L versus Q_H seen in a redox titration and the relative amounts of the low and high potential forms of the PSII-associated Cyt b_{559} (Horton and Croze, 1979); the relative amount of Q_L is much larger in PSII particles prepared with the detergent Triton X-100 (Ke *et al.*, 1976; Horton and Croze, 1979), where Cyt b_{559} is known to be in a low potential ($E_m = +55$ mV) form (Hind and Nakatani, 1970).

The two fluorescence quenching components seen in these redox titration experiments may be related to the well-documented observation that the fluorescence rise curve measured in the presence of DCMU, which indicates reduction of the primary acceptors, has at least two kinetic phases (Joliot and Joliot, 1973), with rate constants denoted k_α and k_β for the fast and slow phases in a two component deconvolution of the data (Melis and Homann, 1975). At the present time, it is not clear whether (a) Q_L is the more efficient, and Q_H the less efficient of the two

quenching components (Melis, 1978; Horton and Croze, 1979); or whether (b) Q_H is the major quenching component (Cramer and Butler, 1969; Bowes *et al.*, 1981). Hypothesis (a) is supported by k_a being associated with reduction of Q_L when the rate of the fluorescence rise is measured at different redox potentials (Melis, 1978; Horton and Croze, 1979). The latter hypothesis is supported by Q_H generally being the component of larger magnitude in titrations of the fluorescence yield in chloroplasts and by reduction of Q_H correlating with light-induced formation of the C550 band indicative of the PSII acceptor (Erixon and Butler, 1971). In these respects, Q_H resembles the Q_1 component defined by Joliot and Joliot (1979, 1981) from studies of the heterogeneity of the PSII acceptors in which two quenching components, Q_1 and Q_2 , were defined. The reduction of Q_1 correlates with a rapid formation of the 518 nm absorbance change indicative of transmembrane charge separation (Joliot and Joliot, 1981).

It has recently been inferred that Cyt b_{563} can be reduced by the less efficient quencher of PSII, which might provide an additional role for this secondary quencher (Joliot and Joliot, 1981). Thus, the heterogeneity in the kinetics of reduction of these acceptors, as well as their reoxidation, may reflect different roles for the two quenchers or acceptors operating at different potentials. A structural heterogeneity in the antennae of PSII may also be a factor in the heterogenous kinetic and functional behavior of the primary acceptor of PSII (Joliot and Joliot, 1979; Melis and Duysens, 1979). For another recent discussion of the relationships between the various forms of Q , see Vermaas and Govindjee (1981).

D. The Secondary Electron Acceptor in Chloroplasts and Algae

It has been shown in chloroplasts and intact algae, as well as in the bacterial chromatophores and reaction centers mentioned earlier, that a second quinone is able to act as the secondary electron acceptor. This component forms a semiquinone anion on reduction with one electron, which is not readily oxidized, but the quinol formed on reduction by a second electron is rapidly oxidized by the chain. The evidence for electron storage on the secondary acceptor is based on observations of a binary pattern of redox behavior as a function of flash number. The existence of an electron storage component in chloroplasts was inferred from a periodicity observed in the transfer of electrons from PSII to PSI (Bouges-Bocquet, 1973), in the increase of fluorescence caused by the addition of dithionite or DCMU after flash preillumination (Velthuis and Ames, 1974), and in *Chlorella* under anaerobic conditions from the

rate and magnitude of the fluorescence changes after illumination with one or two flashes (van Best and Duysens, 1975). This secondary two electron acceptor was called "B" or "R" (Bouges-Bocquet, 1973; Velthuys and Amesz, 1974), which has perhaps led to some confusion in notation. For the purpose of the present work, we will call this component Q_B ($\equiv Q_{II}$) in order to emphasize the analogy with the chromatophore system. Component Q_B was postulated to be a quinone species to account for its ability to function, although transiently, as a two electron acceptor. Much stronger evidence for Q_B being plastoquinone was obtained from the measurement, in chloroplasts inhibited on the donor side of PSII, of absorbance changes at 320 nm in the near UV associated with formation of the plastosemiquinone anion (Mathis and Haveman, 1976; Pulles *et al.*, 1976). The decay of the 320 nm absorbance change associated with $Q_B^{\cdot -}$ occurred in 1.2 msec at 9°C, which is close to the rate-determining step (~ 0.6 msec at room temperature) associated with electron transport in PSII. Electron transfer from the primary acceptors Q_A and Q_B to the plastoquinone pool, PQ, was proposed to occur in chloroplasts as

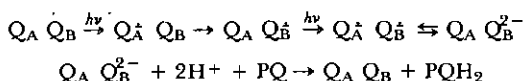

Bowes and Crofts (1980) measured the decay of the high fluorescence yield produced on reduction of Q_A by illumination of chloroplasts with a strong flash and showed that the rate of decay was much more rapid ($t_{1/2} \sim 200\text{--}300 \mu\text{sec}$) for the reaction $Q_A^{\cdot -} Q_B \rightarrow Q_A Q_B^{\cdot -}$ than for the reaction $Q_A^{\cdot -} Q_B^{\cdot -} \rightarrow Q_A Q_B^{2-}$ ($t_{1/2} \sim 600\text{--}800 \mu\text{sec}$), which showed a lag phase before reaching maximal rate. They have suggested that the different rates reflect different redox potentials for the couples $Q_B/Q_B^{\cdot -}$ and $Q_B^{\cdot -}/Q_B^{2-}$, with the former being more oxidizing.

The preceding scheme assumes that there is just one primary quinone acceptor, which, from the values of the equilibrium constants summarized later for electron transfer between primary and secondary quinone acceptors, would have to be Q_H . Estimations of the equilibrium constants (Bouges-Bocquet, 1975; Diner, 1977) for the different reactions between primary and secondary acceptors, and the pool along with differences, ΔE_m , in midpoint potentials (Bendall, 1977) have varied widely. Values for the E_{m7} of the quinone pool have been obtained by extraction experiments (Okayama, 1976) and by measurement of the area over the fluorescence induction curve (Golbeck and Kok, 1979; Thielen and van Gorkom, 1981), giving values of 80 mV (for the extractable PQ) or ~ 120 mV (for the induction area). Equilibrium constants for the reactions

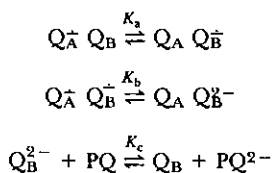

have been estimated to be $K_a = 15-20$, $K_b > 50$, $K_c \sim 1$ (Diner, 1977), or $K_a = 20$, $K_b = 0.5$, $K_c \sim 1$ (Bouges-Bocquet, 1975). A part of this variation may be due to the fact that the experiments used to estimate equilibrium constants were performed under conditions in which the protonation state of the reactants was undefined. In the case of high potential Q_A the E_m value for the couples Q_A/Q_AH^+ at pH 7 (~ -20 mV) and Q_A/Q_A^+ ($E_m \approx -130$ mV) differ by approximately 110 mV corresponding to a change in equilibrium constant of ~ 70 . A further discussion of these points is given by Diner (1977) and Bowes and Crofts (1980). In preliminary redox titrations of the rate of disappearance of Q_A^+ using a fluorescence technique, it was found that the difference in rate between the first and second flash titrated with $E_{m7} \sim 130 \pm 20$ mV, suggesting a similar value for the E_m of the couple $Q_B^{\dot{B}}/Q_B$, or Q_BH^+/Q_B (J. M. Bowes and A. R. Crofts, unpublished observations). This value is close to the value for E_{m7} of the pool, and suggests that if the Q_B site is in equilibrium with the pool, the stability constant for formation of $Q_B^{\dot{B}}$ is about 1. In the light of these results, the relatively small redox gradient favoring $Q_B^{\dot{B}}$ in the scheme of Bendall (1977) would not by itself account for the long-term stability of the semiquinone at physiological pH. Thielen and van Gorkom (1981) recently made an extensive study of the potentials of the components of the acceptor complex and suggested an interesting model based on the assumption that the couple $Q_A Q_B$ is reduced by a pair of electrons to provide the titration usually ascribed to Q_H , followed by a one-electron titration to give Q_L :

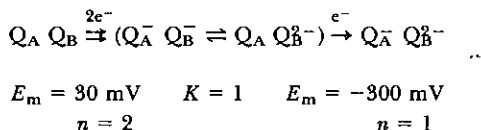

The titrations for these experiments were performed using dithionite in the absence of redox mediators, and the wide divergence of the value for Q_H from those previously reported may indicate that some of the one-electron components of the system were not titrated at equilibrium.

The rapid light-induced formation of Q_A^+ , the anionic nature of the semiquinones, and the pH independence of the rates of the reactions,

$Q_A^+ Q_B \rightarrow Q_A Q_B^+$ and $Q_A^+ Q_B^+ \rightarrow Q_A Q_B^{2+}$, imply that these reactions are not in equilibrium with protons of the bulk medium and suggest that proton uptake occurs at the level of reduction of the plastoquinone pool (Bendall, 1977). Since the secondary electron transfer reactions between Q_A and Q_B occur on a time scale that could allow protonation reactions to occur, the lack of protonation of secondary quinone would imply that this component may be in an aprotic, hydrophobic environment that is protected from the outer aqueous phase. However, it should be noted that no binary pattern is observed in the proton uptake on flash illumination of dark-adapted chloroplasts, as would be expected if H^+ uptake is linked to PQ (pool) reduction. A mechanism such as that discussed by Wraight (1979, 1981) for bacterial reaction center H^+ binding would resolve this paradox.

E. Quinone-Binding Proteins

The experimental evidence supporting the existence of a quinone apoprotein for the acceptor Q_B in chloroplasts is circumstantial at the present time and is based to a significant extent on the properties of the inhibition of DCMU and other herbicides: (a) the site of action of DCMU is immediately after the primary acceptor Q_A (Duysens and Sweers, 1963; Duysens, 1972), as is that of the atrazine herbicides; (b) the ability of trypsin to remove the DCMU-binding site implies that this site is proteinaceous (Regitz and Ohad, 1976; Renger, 1976; Trebst, 1979); (c) the herbicide-binding protein has been identified with respect to its M_r value (≈ 32 kD) on gels through the use of photoaffinity labeled analogs of inhibitors acting in a manner similar to DCMU (Oettmeier *et al.*, 1980; Steinback *et al.*, 1981); (d) stabilization of the semiquinone anion $Q_B^{\cdot-}$ and DCMU-induced modification of the redox properties of this anion (Velthuys and Ames, 1974) are more readily explained by a proteinaceous binding site for Q_B ; and (e) atrazine-resistant weeds have a modified binding site for the atrazines, modified electron transfer from Q_A^+ to Q_B , and an altered molecular value of the 32kD protein (Arntzen *et al.*, 1979; Bowes *et al.*, 1980). The preceding points (a)–(e), together with the proximity of Q_A and Q_B to the site of action of DCMU, lead to the hypothesis that plastoquinone is a coenzyme or prosthetic redox group of the DCMU binding protein. The apoprotein appears also to contain a high affinity binding site for bicarbonate (Govindjee and van Rensen, 1978; Khanna *et al.*, 1981). Bowes and Crofts (1981), Velthuys (1981b), and Wraight (1981) discussed mechanisms of inhibition in terms of competition at the Q_B site between Q_B , or PQ or PQH_2 from the pool, and a number of inhibitors. A topographical model of the

chloroplast intersystem electron transport chain, indicating exposure of the Q_B -protein (Trebst, 1979; Steinback *et al.*, 1981) to the outer aqueous phase is shown in Fig. 4.

Other biochemical evidence for the existence of quinone-binding proteins in energy transducing membranes comes from studies on mitochondria. The amount of ubisemiquinone in the purified Cyt *b-c*₁ complex, as detected by a free radical ESR signal at $g = 2.00$, can be a large fraction of the total ubiquinone in the complex (Ohnishi and Trumppower, 1980; Yu and Yu, 1980; de Vries *et al.*, 1981). This relatively large concentration of semiquinone has led to the conclusion that the intermediate must be stabilized by interacting with a protein. The other data leading to this conclusion were that phospholipids alone did not stabilize the ubisemiquinone radical, and that the concentration of the radical decreased as a function of time of treatment with α -chymotrypsin (Yu and Yu, 1980). The putative ubiquinone protein in the *b-c*₁ com-

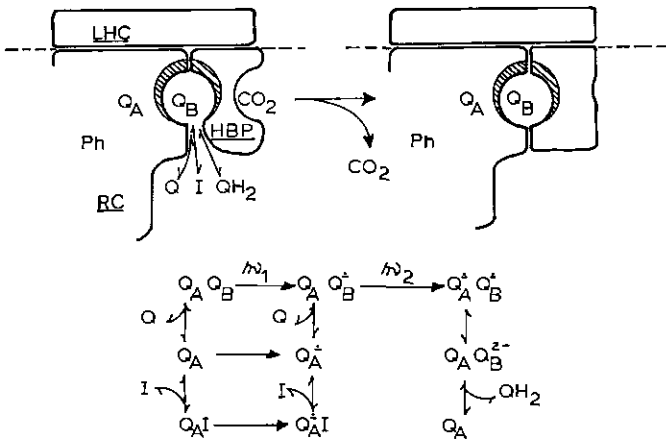

FIG. 4. The quinone acceptor complex of PSII, showing activators and inhibitors. The scheme shows three protein complexes, the light-harvesting chlorophyll *a-b* protein complex (LHC), which appears to act as a barrier to proton accessibility (Ausländer and Junge, 1974; Renger and Tieman, 1979); the PSII reaction center (RC) containing the intermediate pheophytin acceptor (Ph), and the primary plastoquinone acceptor (Q_A); the 32 kD herbicide binding protein (HBP) containing binding sites for herbicides (shown as shaded) and CO_2 , and a catalytic site at which the secondary plastoquinone acceptor (Q_B , also called B or R in the literature) reacts with the primary acceptor. The quinone antagonists (I) are shown as competing with the different redox species of quinone from the pool (Bowes and Crofts, 1981; Velthuys, 1981b). The herbicides are shown as sharing a common binding site, which is also influenced by CO_2 (Govindjee and van Rensen, 1978; see W. F. J. Vermaas and Govindjee, in Govindjee, Vol. II, 1982; Govindjee *et al.*, 1976; Radmer and Ollinger, 1980).

plex has been called QP-C. A second quinone protein from mitochondria, which is necessary in catalytic amounts for reduction of Cyt *c* by succinate and is believed to be reduced directly by succinate dehydrogenase, is denoted QP-S and has been isolated (Yu and Yu, 1980).

The resistance to extraction by organic solvents, such as isooctane, has led to the suggestion that component 'Z' (Evans and Crofts, 1974b) in the electron transport chain of chromatophores, a two-electron redox component with a midpoint potential of +155 mV (Prince and Dutton, 1977), may also arise from bound ubiquinone (Takamiya and Dutton, 1979). Approximately 25 ubiquinones per reaction center can be extracted from chromatophores, leaving 2 ubiquinones in the reaction center together with 1-4 other ubiquinone molecules showing kinetic and redox properties similar to those of 'Z' (Takamiya *et al.*, 1979). Further extraction of quinone leads to loss of the phenomena associated with 'Z', providing additional support for its identification as a quinone at a binding site, presumed to be proteinaceous, and justifying the name Q_Z (Crofts and Wood, 1978; Dutton and Prince, 1978b). However, Crofts *et al.* (1975) previously noted that the redox range over which an acceleration of the re-reduction of Cyt *c*₂ occurred was close to that at which the quinone pool would have been reduced to the extent of 1 QH₂/chain, and had later shown (Crofts *et al.*, 1977) from the second-order kinetics that the concentration of reductant for Cyt *c* present at E_{h7} ~ 100 mV, where the rate of re-reduction was maximal, was at least four-fold in excess of that required to reduce Cyt *c* stoichiometrically; this observation was never satisfactorily explained by the hypothesis of a specific bound quinone, Q_Z. Rich and Bendall (1980) suggested that the phenomena associated with Q_Z may in part be explained by reaction of the ubiquinol oxidase complex with quinol from the pool in a second-order process (Rich, 1982), and a re-evaluation of the kinetics of the phenomena associated with Q_Z have lent considerable support to this view (Crofts *et al.*, 1982c). The role of quinones in relation to specific electron transfer mechanisms is discussed more extensively later.

F. Membrane Surface Potential in Photosystem II

The rate of electron-transport to ferricyanide as a Hill acceptor in PSII of chloroplasts is dependent upon ionic strength. The higher the ionic strength or the lower the pH, the faster the rate of ferricyanide reduction (Itoh, 1978a). This effect has been attributed to the existence of a negative potential on the surface of the membrane where there is a hydrophobic barrier to the penetration of the triply charged ferricyanide anion. The increase in the rate of ferricyanide reduction caused

by an increase in the concentration of added salt or protons is attributed to shielding of the negative surface potential responsible for repelling the ferricyanide in the outer aqueous medium (Itoh, 1978a). For small values of the surface potential, ψ_o , its value is given by $\psi_o = 4\pi\sigma/D\kappa$, where σ is the surface charge density, D the dielectric constant of H_2O , and $1/\kappa$ the characteristic Debye-Hückel length. By measuring the rate of ferricyanide reduction by PSII in sonicated chloroplasts as a function of salt concentration, a value of $\psi_o = -25 - -30$ mV was estimated for the surface potential near PSII at pH 7.5 in the presence of low concentrations of salt, and a value of +17 mV at pH 4.9. The former ψ_o value was found to correspond to a surface charge density of about $-0.6 \mu C/cm^2$. Larger values of ψ_o and the surface charge density, -60 mV and $-1.3 \mu C/cm^2$, respectively, were obtained from the salt dependence of the ferricyanide oxidation of the primary acceptor of PSII (Itoh, 1978b).

There also appears to be a heterogeneity in the membrane surface with respect to the membrane potential. A much smaller value for the ψ_o in PSI was inferred from the smaller effect of salt on the rate of electron transport to ferricyanide in intact chloroplasts (Itoh, 1978a), and the salt dependence of the rate of P700 reduction by ferrocyanide (Itoh, 1979). An asymmetry of surface charge, with a value of $-2.2 \mu C/cm^2$ outside, and of $-3.4 \mu C/cm^2$ at the inner surface affecting electron donation to PSII associated with ESR signal II_r by charged external donors, has been inferred by Yerkes and Babcock (1981). Changes in membrane surface potential will affect membrane properties including surface pH, transmembrane potential (Barber, 1981), and the apparent E_m of redox components located near the membrane surface (Itoh, 1980).

V. Cytochromes

A. Protein Chemistry*

Chloroplasts and algae contain two, and possibly three, *b*-type Cyts that have been purified, as well as the membrane-bound Cyt *f*. The *b*-type Cyts that have been purified are b_{559} , b_{563} (b_6), and a soluble b_{560} . A subunit M_r value of approximately 6 kD for a Cyt b_{559} lipoprotein from spinach has been found in three laboratories (Garewal and Wasserman, 1974; Zielinski and Price, 1980; Satoh, 1981), but has been found to be 37 kD in another (Lach and Böger, 1977a). A value of 6 kD for the

*Also see Table I.

subunit polypeptide M_r value of Cyt b_{559} would be the smallest of any known Cyt. The smallest known polypeptide among other b Cyts is that of the soluble *E. coli* b_{562} with a M_r value of 12 kD, and the smallest c-type Cyts, with 81–82 amino acids, have M_r values of approximately 10 kD (Almasy and Dickerson, 1978). Thus, 6 kD appears to be too small to enclose a heme. The resolution of these problems appears to be that the 6 kD polypeptide measured on gels is a result of proteolysis. The major polypeptide seen on urea-SDS gradient gels after preparation in the presence of protease inhibitors is approximately 10 kD (Widger and Cramer, 1982). The subunit M_r value of the Cyt b of mammalian mitochondria is estimated to be 21–38 kD (von Jagow and Sebald, 1980). A value of 17 kD has been reported for the b_{559} from the blue-green alga *Bumilleropsis filiformis* (Lach and Böger, 1977a) and 30 kD for a soluble b_{560} from spinach (Matsuzaki and Kamimura, 1972).

Cytochrome b_6 has been found to be a tetrameric lipoprotein of heterogeneous polypeptide composition in one laboratory (Stuart and Wasserman, 1975), and a single polypeptide with M_r value 18 kD in another (Lach and Böger, 1977b). The measurement of 18 kD appears more likely to be approximately correct at present, because of the isolation of a Cyt b_6 - f complex containing the FeS center and only five polypeptides on an SDS gel, with M_r values of 34, 33, 23, and 17.5 kD (Hauska *et al.*, 1981). Very good agreement exists on the M_r value or minimum M_r value of Cyt f , with a value near 35 kD found in at least nine different studies. The two axial ligands of the heme of Cyt f have recently been inferred to be histidine and lysine for the oxidized Cyt at pH = 8.0 (Siedow *et al.*, 1980), unlike Cyt c whose axial ligands are histidine and methionine.

B. The Cytochrome b - c_1 Complexes

The initial interest in these complexes may stem from extensive study of the Cyt b - c_1 complex in mitochondria. A chloroplast b_6 - f complex with a Cyt stoichiometry of $2b_6:f$ was first isolated by Nelson and Neumann (1972). These workers noted that the $b_6:f$ ratio tended to decrease and the b_6 α band peak to shift to shorter wavelengths in the later steps of purification. This may be the reason why the presence of a low potential form of Cyt b_{559} has sometimes been reported in the isolated complex. A preparation using octylglucoside as the detergent, indicates the presence of the 5 polypeptide bands (M_r values = 34, 33, 23, 20, and 17.5 kD) mentioned earlier, 2 b_6/f and 2 non-heme iron/ f , and an absence of Cyt b_{559} in a preparation that preserved plastoquinol:plastocyanin reductase activity (Hauska *et al.*, 1981). The 2:1 stoichiometry of

$b_6:f$ is of interest because of evidence that the mitochondrial Cyt b of the $b-c_1$ complex and complex III is present in a stoichiometry of $2b/c_1$ and that there are at least two distinct in situ forms, b_{562} and b_{566} with distinct spectral, redox, and kinetic characteristics. The b -type Cyts of the chromatophore complex also show similar characteristics (see below). The redox potential of Cyt b_6 has been measured by titration to be (a) $E_{m8} = +5$ mV, where the Cyt was also found to be labile with respect to a negatively directed shift in potential (Böhme and Cramer, 1973); and (b) $E_{m7} = -110$ mV and pH independent; approximately the same value was obtained in b_6-f particles (Rich and Bendall, 1980b).

The High Potential Fe-S Center: Rieske *et al.* (1964a) purified an iron protein from complex III of mitochondria, after succinylation of a crude preparation. The succinylated protein had a M_r value of 26 kD, a broad visible absorption spectrum with peaks of the oxidized protein at 575, 460, and 315 nm, and a $g = 1.90$ ESR signal in the reduced form. The acid labile sulfur (S^*) content of the protein was 0.7–0.8 moles/gram atom Fe, and the Fe-S linkage appeared to be a $2Fe-2S^*$ cluster (Rieske *et al.*, 1964a, b). The midpoint potential varied between +180 and +290 mV (Rieske, 1976). An FeS center with similar ESR characteristics and similar E_m was found in several photosynthetic bacteria (Evans *et al.*, 1974; Prince *et al.*, 1975). The E_m values were independent of pH in the range 6.3–8.0 and decreased by 60 mV per pH unit increase between pH 8 and 10 in *Rp. sphaerodes* chromatophores (Prince and Dutton, 1976). Further studies on the function of an FeS protein (called the "oxidation factor" of the $b-c_1$ segment), which is required for succinate-Cyt c reductase activity indicate that it is probably identical to the Rieske protein. It apparently has the same molecular weight (Trumppower and Edwards, 1979) and is required for electron transfer from succinate and from ubiquinol to Cyt c_1 ; it is needed for the reduction of both Cyts b and c_1 in the presence of antimycin A, for the reoxidation of succinate-reduced Cyt b by Cyt c and Cyt oxidase, and for the oxidant-induced reduction of Cyt b (Bowyer *et al.*, 1981b). The above background on the biochemical properties of the high potential "Rieske" FeS protein in mitochondria is mentioned here because the protein has many similar properties in chromatophores and chloroplasts. It has recently been isolated from the latter system (Hurt *et al.*, 1981).

Much of the information on the optical and EPR spectral properties of $2 Fe-2S^*$ proteins (Fig. 1E) is derived from studies on the $2Fe-2S^*$ ferredoxin proteins (Beinert, 1977; Cammack *et al.*, 1977; Palmer, 1977). The minimal iron-sulfur structure is $[Fe_2S_2^*(S-Cys)_4]$ containing two tetrahedrally coordinated iron atoms bridged by two sulfurs (S^*), which can be released as H_2S upon acidification of the protein (Fig. 1E).

The g values of the reduced "Rieske" protein are 2.02, 1.89, and 1.81, with no net paramagnetism observed in the oxidized state at low temperature. A model has been proposed for the $2\text{Fe}-2\text{S}^*$ center, which explains the magnetic properties, in which the two iron atoms of the oxidized protein are high spin Fe^{3+} ($S = 5/2$), antiferromagnetically coupled to give zero net spin at low temperatures. Upon reduction, one of the Fe atoms is reduced to high spin Fe^{2+} ($S = 2$), and the antiferromagnetic coupling then gives a net low spin ($S = 1/2$).

The presence of a "Rieske"-type FeS center in chromatophores was deduced from observations of a $g = 1.90$ signal in the dark that titrated with a characteristic midpoint potential and was eliminated upon illumination of the chromatophores (Evans *et al.*, 1974; Prince *et al.*, 1975). A similar $g = 1.89-1.90$ signal has been titrated in the dark in chloroplasts with a midpoint, at $\text{pH} = 6.5-8.0$, of $+290$ mV in chloroplasts (Malkin, 1975), and $+330$ mV in the b_6-f complex (Rich *et al.*, 1980). The signal was eliminated by illumination with PS1 light (Whitmarsh and Cramer, 1979a; Malkin and Chain, 1980).

C. Kinetics of Electron Transfer

Participation of Cyt b_6 in a cyclic pathway around PS1 is defined by its photoreduction through ferredoxin (Böhme, 1976) in ~ 1 msec and dark oxidation in 10–20 msec (Slovacek *et al.*, 1979, 1980), through an uncoupler- and DBM1B- sensitive site (Böhme and Cramer, 1972). Reduction of Cyt b_6 by PSII also occurs (Rumberg, 1966; Weikard, 1968), which has been found to be DCMU- sensitive in some cases (Böhme and Cramer, 1972; Heber *et al.*, 1976; Böhme, 1979, 1980; Velthuys, 1979), but not always (Joliot and Joliot, 1981), and insensitive to an antibody to ferredoxin (Böhme, 1980). The rate (Velthuys, 1979) and amplitude (Böhme, 1979) of photoreduction are increased when the plastoquinone pool is more reduced. Involvement of Cyt b_6 reduction in a 'Q loop' associated with charge separation and formation of a slow electrochromic phase was proposed by Velthuys (1979). The general 'Q loop' model predicts that reduction of b_6 requires reduction of the FeS protein in a concerted reaction. This prediction has recently been verified (Prince *et al.*, 1982). It is of interest to note that the kinetics of photoreduction of a Cyt b with an $E_{m7} = +50$ mV (to be referred to as cyt b_{561} in this chapter) in chromatophores of *Rp. capsulata* and *Rp. sphaeroides* are dependent upon the formation, or the presence before a flash, of oxidized FeS (Bowyer and Crofts, 1981).

Cytochrome f has traditionally been regarded as a redox component, which behaves in a relatively straightforward manner. A great deal of

early data of several kinds (spectrophotometric, biochemical, and genetic) defined a simple function for this Cyt as an intersystem electron carrier where it responds to the push-pull influence of red and far-red light (summarized in Whitmarsh and Cramer, 1979b). Some aspects of Cyt *f* response, the significance of which is not understood, include (1) an apparently different degree of equilibration with plastocyanin and P700 in the dark and light (Marsho and Kok, 1970), which may relate to a change of position of the Cyt in the membrane (Horton and Cramer, 1974); and (2) a lack of understanding of the amplitude and kinetics of Cyt *f* redox changes after a single turnover flash. The relatively small ($\sim 0.4 f:700$) amplitude of Cyt *f* oxidation after a single turnover flash can be partly explained by a rapid reduction of the oxidized Cyt ($E_{m7} \approx +360$ mV) by the initially reduced high potential (+290 - +330 mV) FeS protein (Koike *et al.*, 1978) and by equilibration with the FeS protein as well as one or more copper centers of the plastocyanin ($E_{m7} = +370$ mV). If the E_{m7} of the FeS protein were +290 mV, and equilibration between the FeS center and Cyt *f* occurred rapidly after electron transfer to P700⁺ formed on a single turnover flash, then the net oxidation of Cyt *f* after such a flash would be expected to be < 10%. The amplitude of the Cyt *f* reduction after an extended series of closely spaced flashes was found to be less than 1 *f*:P700 (Haehnel, 1973). It was also pointed out by Haehnel (1973, 1977) that the detailed time course of both the oxidation and reduction of the Cyt should be sigmoidal, i.e., contain a delay, if the Cyt functions in a linear chain of carriers. The delay in reduction was much smaller than predicted (Haehnel, 1977). A sigmoidal time course for the flash-induced photo-oxidation of Cyt *f* in *Chlorella* was, however, observed by Bouges-Bocquet (1977). The problem of the time course of reduction of Cyt *f* after a long 300 msec flash, which oxidizes all of the donors of PSI and establishes steady state conditions of ΔpH and phosphorylation, has been considered by Whitmarsh and Cramer (1979b, 1980). The amplitude of Cyt *f* turnover was consistent with an *f*: P700 stoichiometry of 1. The ratio of 5-6 in the half-time of Cyt *f* reduction to that of P700 could be largely predicted by an analytical consideration of the reduction through a linear chain in which the Cyt is the third component reduced after P700 and plastocyanin. The predicted kinetics for reduction by plastoquinol of four components, FeS-Cyt *f*-PC-P700, in a linear chain, yielded a ratio of 3.4 for the ratio of reductive half-time of Cyt *f* and P700, when the simplest choice of rate constants was made for the successive electron transfer steps from the plastoquinol pool. It was proposed that the somewhat larger measured value of the ratio of these half-times could be due to the decrease, with successive transfer of electrons after the long flash, of the

positive charge on $P700^+ - PC^+ - Cyt f^+ - FeS^+$, resulting in a lowered affinity of Cyt *f* or the FeS center for the electron from plastoquinol. (Whitmarsh and Cramer, 1980). Further considerations of the reaction between Cyt *f* and plastocyanin may also have to take account of the inference that PSI is mostly absent from the grana stacks (see Kaplan and Arntzen, Chapter 3, this volume; I. Ohad and G. Drews, Chapter 5, in Govindjee, 1982). In this case, PSII would have to transfer electrons to PSI at the grana periphery (Anderson, 1981), and plastocyanin may play a major role as a mobile carrier in transgranal electron transfer.

Kinetic information on the FeS center in chromatophores has become available through the use of the inhibitor 5-*n*-undecyl-6-hydroxy-4, 7-dioxobenzothiazole (UHDBT) (see Fig. 2D). UHDBT interacts very close to, or with, the Rieske FeS protein, as it blocks the photo-oxidation of the FeS center, shifts its *g* value from 1.90 to 1.89, and its E_{m7} from +280 to +350 mV (Bowyer *et al.*, 1980). The ability of the FeS center to rapidly (< 1 msec) reduce the photo-oxidized Cyt *c* complex of the chromatophores is illustrated by the approximate doubling in amplitude of Cyt *c* oxidation by a single flash in the presence of UHDBT. The interpretation of this experiment is that the measured amplitude of Cyt *c* photo-oxidation is diminished in the absence of UHDBT because the electron from the reduced FeS center rapidly reduces and equilibrates with the Cyt *c* complex. Cytochrome *c* consists of approximately equal amounts of the loosely bound Cyt c_2 ($E_{m7} \approx +340$ mV) and a bound form of Cyt *c* (see discussion and Figs. 6 and 7 later). As in the chloroplast case discussed earlier, the FeS center has a lower E_m than the Cyt c_2 , so that after a single turnover flash, one-half the Cyt *c* (most of it c_2) is reduced by the electron initially on the FeS center. Transfer of this electron is blocked by UHDBT resulting in complete oxidation of one equivalent of Cyt *c* after the flash. A generally similar result has been obtained for the amplitude of flash-induced Cyt *f* oxidation in the presence and absence of the putative inhibitors, DBMIB and bathophenanthroline (Koike *et al.*, 1978) and UHDBT (Whitmarsh *et al.*, 1981) of the FeS center in chloroplasts. DBMIB was originally thought to be a plastoquinone antagonist (Böhme *et al.*, 1969). The fact that DBMIB at low concentrations eliminates and possibly shifts the $g = 1.90$ signal in chloroplasts (Malkin, 1981b) now suggests that its site of action, which is believed to be specific at the low concentration of $1 \mu M$ usually employed, is close to the FeS center in chloroplasts, where it may react with or displace a bound quinone. It seems likely that UHDBT also acts at the Rieske center in chloroplasts (Whitmarsh *et al.*, 1981). Although one site of action of UHDBT in chloroplasts appears to be near the FeS center, it also appears to inhibit electron transfer from Q_A at concentrations (≈ 1

μM) lower than those at which it reacts near the FeS center (Malkin, 1981a; Oettmeier *et al.*, Whitmarsh *et al.*, 1981). DBMIB at higher concentrations also inhibits at a similar site near Q_A (de Kouchkovsky and de Kouchkovsky, 1974; Bowes and Crofts, 1981; Velthuys, 1981b).

D. Chloroplast Cytochrome b_{559} : Properties and Function

Two redox forms of Cyt b_{559} have been well described in systematic redox titrations: high and low potential forms with midpoint potentials at pH 7–8 of +350–400 mV and +50–+100 mV (reviewed in Cramer and Whitmarsh, 1977). An intermediate potential form in NH_2OH -treated chloroplasts has been described with an $E_m \approx +240$ mV (Horton and Croze, 1977), though a continuous range of redox forms may exist in this intermediate range in chemically treated chloroplasts (Erixon and Butler, 1971). Two or three ranges of values of midpoint potentials, ranging from "high" to "intermediate" to "low," can be distinguished in a rapid assay by reduction of oxidized b_{559} with (a) ferrocyanide or hydroquinone; (b) ascorbate; and (c) dithionite. The use of menadiol as a reductant slightly stronger than ascorbate should allow an even more finely graded rapid assay (Rich and Bendall, 1980b). In freshly prepared chloroplasts, there are about two equivalents of high potential b_{559} per reaction center and one at a lower potential which is reducible by menadiol or dithionite. The rapid redox assay may give a truer description of the qualitative distribution of the Cyt between different potential regions, as the long time required for complete redox titration may shift the distribution toward lower potential. The very positive ($\sim +0.4$ V) potential is unusual for a b -type Cyt and could be a consequence of an unusually hydrophobic environment due to the local presence of plastoquinone or β -carotene (Okayama and Butler, 1972; Cox and Bendall, 1974), local proximity of cations such as Mn^{2+} (Cramer *et al.*, 1981a) or other sources of positive charge such as protonation of the Cyt or the surface-exposed peptide of the light-harvesting chlorophyll protein (Steinback *et al.*, 1979). These considerations could also be involved in the explanation of the relatively high potential (+240 mV and +400 mV) of b Cyts in chromatophores of *Rp. capsulata* from dark-grown cells (Zannoni *et al.*, 1974). The redox potential of the purified Cyt b_{559} (studied by Garewal and Wasserman, 1974) indicated that the protein as isolated had an "intermediate" potential, since it was reducible by ascorbate. It is difficult to know whether or not the E_m of the isolated protein is the same as that of the protein *in situ*. A negatively directed shift in the E_m of b -type Cyts upon removal from the membrane is a well-docu-

mented phenomenon. On the other hand, it has been possible to titrate the mitochondrial Cyt *b* of complex III at values close to those obtained in situ when the Cyt was solubilized in detergent (von Jagow and Sebald, 1980). In the case of high potential b_{559} , its high potential state would surely be lost upon isolation if this state was dependent on the presence of the membrane.

The question of whether the relatively low potential (LP) b_{559} found in freshly prepared chloroplasts is an independently functioning redox component is complicated by the fact that high potential (HP) b_{559} is labile and readily converted to lower potential forms by treatments such as heating, trypsin, detergent, NH_2OH , Tris, and so on. Because an appreciable amount of the low potential form of Cyt b_{559} can be found in freshly prepared chloroplasts it has been proposed that low and high potential forms of b_{559} are different proteins, or proteins in different environments under physiological conditions (Rich and Bendall, 1980b).

The different functions that have been proposed for Cyt b_{559} are (a) redox function in water splitting; (b) participation as an electron and H^+ carrier in the main chain; (c) a redox carrier in a cycle around PSII (Heber *et al.*, 1979); (d) a redox carrier on a side path, branch or cycle from the plastoquinone pool (Whitmarsh and Cramer, 1977, 1978); (e) reduced b_{559} as an H^+ acceptor for the S_2 state of the water-splitting complex (Butler, 1978); and (f) overlap or interaction of b_{559} with the DCMU binding site (Horton *et al.*, 1976). There are virtually no data at all on light-induced turnover of intermediate (IP) or low potential b_{559} . Hypotheses (c), (d), and (f) explicitly concern HP b_{559} . (b) and (c) involve interconvertibility, by protonation, of LP, IP, or HP forms of the Cyt. A basic experimental difficulty confronted in situ with this Cyt is that the amplitude of the light-induced absorbance changes of HP b_{559} in well-functioning chloroplasts is small and/or slow. For this reason, the great stimulation in amplitude and rate of photo-oxidation that occurs in the presence of lipid-soluble uncouplers, which are ADRY (Renger, 1972) reagents, that accelerate the deactivation of the water-splitting system, (Olson and Smillie, 1963; Cramer and Butler, 1967; Ben-Hayyim, 1974; Heber *et al.*, 1979; Maroc and Garnier, 1979; Velthuys, 1981a) has attracted much experimental attention. The ADRY reagent data suggest that Cyt b_{559} may be a donor to the S states and that the resulting deactivation of water-splitting and cyclic flow around PSII could become significant at low ambient light intensities (Cramer *et al.*, 1979).

The branched electron transport chain [function (d) listed earlier] appears also to be a topographical branch, with electron transfer to the PSI donors toward the inside of the membrane and at a slower rate, to Cyt b_{559} near the outer aqueous phase. A surface location of the heme of

high potential b_{559} as well as the protein is suggested (a) by the relatively high accessibility to ferricyanide (Horton and Cramer, 1974); and (b) by the effect of trypsin in lowering the E_m of this Cyt (Cox and Bendall, 1974). This effect of trypsin might be attributed to general disruption of the membrane. However, the trypsin effect on b_{559} , measured through the decrease in hydroquinone reduction, occurs more rapidly than does the trypsin effect on the DCMU-binding of the Q_B protein of PSII, thought to be positioned close to the membrane surface (Cramer *et al.*, 1981b). A surface effect of trypsin proteolysis that occurs even more rapidly than that of Cyt b_{559} is the cleavage of the light-harvesting pigment protein (Steinback *et al.*, 1979), which is complete within 3 min at 10°C (Cramer *et al.*, 1981b). Also, the similar effects of DBMIB on increasing the rate of b_{559} and ferricyanide (FeCy) reduction had suggested that b_{559} might participate in the $H_2O \rightarrow DBMIB-FeCy$ pathway, with ferricyanide accepting electrons from b_{559} at the outside of the membrane (Whitmarsh and Cramer, 1978).

Location of at least one molecule of high potential b_{559} per reaction center close to the outer aqueous phase of the membrane is implied by the preceding data. Such a location begs for identification of the natural high potential electron acceptor for this Cyt. A redox function for Cyt b_{559} close to the inside of the membrane, on the other hand, is implied by the ability of PSII to photo-oxidize b_{559} at 77°K (Knaff and Arnon, 1969a) if the electron acceptor for the Cyt at 77°K is near the inside, and the allowed distance of electron transfer is not large (Cramer and Whitmarsh, 1979). Redox functions of b_{559} close to both the outer and inner side of the membrane would imply that a b_{559} functions as a dimeric or oligomeric heme complex (Garewal and Wasserman, 1974), with heme localized near each side of the membrane. Other topographical information available for Cyt b_{559} concerns the orientation of the heme plane relative to the plane of the membrane in preparations of oriented chloroplasts. The dichroic ratio of the α -band of Cyt b_{559} at 77°K indicates that the angle between the heme plane and that of the membrane is greater than 35° (Vermeglio *et al.*, 1980a).

The components of the intersystem electron transport chain of plants and algae are shown against a scale of redox potential in Fig. 5. The dashed lines indicate the organization of the chain into four separate lipoprotein complexes containing the water-splitting enzyme (S_0-S_4), the PSII (P680) and PSI (P700) reaction centers, and the plastoquinol-plastocyanin oxidoreductase containing Cyt b_6 , Rieske FeS, Cyt f , and possibly another molecule of bound plastoquinone (Q_{III} or U; see Section VII,E).

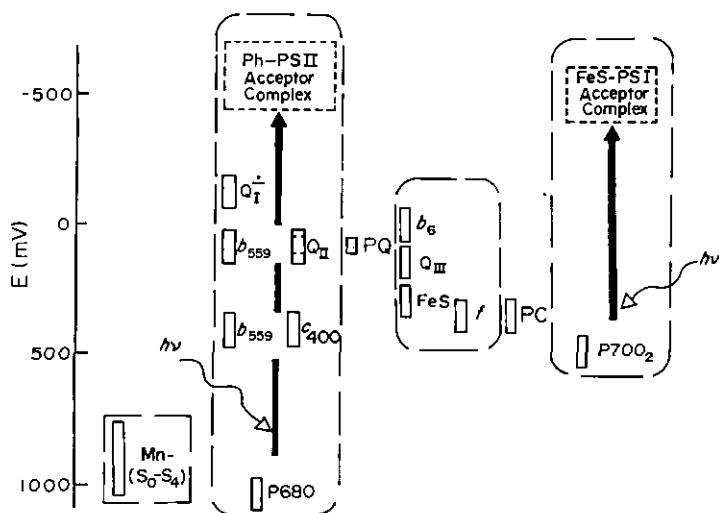

FIG. 5. The components of the electron transport chain of chloroplast shown against a redox scale and distributed in protein complexes (see text for further explanation). Q_I and Q_{II} are Q_A and Q_B of the text. Q_{III} is a putative bound quinone (equivalent to U of the text).

E. The Cyclic Electron Transfer Chain of *Rp. sphaeroides* and *Rp. capsulata*

The following scheme summarizes for *Rp. sphaeroides* our present knowledge of the electron transfer components on the donor side of the reaction center, their stoichiometry (Rel. stoich.) and redox potentials (E_{m7}) in chromatophores, and the half times (t) of their reactions. (A very similar scheme could be drawn for *Rp. capsulata*.)

Component:	QH ₂ →	RFeS →	Cyt c ₁ →	Cyt c ₂ →	[BChl] ₂
Rel. Stoich.:	30	0.5-0.7	0.5-0.6	0.5	1
t :	300 μsec	200 μsec	100 μsec	5 μsec	
E_{m7} (mV):	90	280	270	340	450
Inhibitors:	Myxothiazol	UHDBT	Depletion of Cyt c ₂		

This scheme differs considerably from earlier, generally accepted, schemes (Crofts and Wood, 1978; Dutton and Prince, 1978b). New features of the scheme are as follows:

1. The identification of two different Cyt *c* components in the chain. Wood (1981) has shown on the basis of spectral characteristics, redox

potential, Cyt c_2 depletion experiments, and gel electrophoresis that a species of Cyt c , which differs from the classical Cyt c_2 , is present as a membrane-bound component, analogous to Cyt c_1 of mitochondria. The Cyt is shown as c_1 in the preceding scheme. Bowyer *et al.* (1981a) arrived independently at a similar conclusion on the basis of the spectral differences, differential extractability from spheroplasts, and biphasic kinetics of Cyt oxidation. It has now been possible to measure the separate kinetics of the two Cyts following flash excitation and to unambiguously demonstrate the series mechanism implied in the preceding scheme by measuring time-resolved spectra following flash excitation in the microsecond range (Crofts *et al.*, 1982a). Further evidence for the analogy between the bound Cyt c_1 of chromatophores and the mitochondrial Cyt c_1 has been obtained by Gabellini *et al.* (1982), who have shown that Cyt c_1 co-purifies with Cyt b in a complex similar to the mitochondrial complex III. In chromatophores the total Cyt c ($c_1 + c_2$) is about 1 Cyt c /RC, as determined from the amplitude of flash-induced absorbance changes.

2. As noted earlier (Section V,B), it has been shown through the use of the inhibitory quinone analog, UHDBT, that the electron donor to the c -type Cyts is a component with the stoichiometry and redox properties of the Rieske-type FeS center, RFeS (Bowyer and Crofts, 1978). UHDBT changes both the ESR spectrum and the redox potential of RFeS (Bowyer *et al.*, 1980). Electron transfer to RFeS is inhibited by myxothiazol (Meinhardt and Crofts, unpublished observations; Crofts *et al.*, 1982b); reduction of Cyt c_1 and c_2 by RFeS is insensitive to myxothiazol, but inhibited by UHDBT.

3. The donor to this portion of the chain, the presence of which was originally inferred from the redox potential dependence of the antimycin sensitive reduction of Cyt c (Evans and Crofts, 1974; Prince and Dutton, 1977), has been suggested to be a bound ubiquinone on the basis of differential effects of extraction on the kinetics of Cyt c re-reduction and the slow phase of the carotenoid change (Takamiya *et al.*, 1979). As discussed briefly earlier (Section IV,E) a reevaluation of the dependence on redox potential of the rate of reduction of Cyt b_{561} in antimycin inhibited chromatophores in the light of a revised Q-cycle mechanism (Crofts *et al.*, 1982b), and of the kinetics and stoichiometry of the antimycin sensitive re-reduction of Cyt $c_1 + c_2$, and slow phase of the carotenoid change, have shown that the phenomena previously attributed to a specific bound quinone are adequately and more economically accounted for by a second-order reaction of the ubiquinol-Cyt c_2 oxidoreductase complex with ubiquinol from the pool. Furthermore, extraction experiments have shown that reduction of Cyt b_{561} could occur in chromatophores from which the pool of ubiquinone had been

removed, except for two equivalents per reaction center, of which one was the primary acceptor Q_A , and the second was able to act as a secondary acceptor (Baccarini-Melandri *et al.*, 1982). The reduction kinetics showed a lag (~ 1 msec) and slow half-time ($t_{1/2} \sim 8$ msec) which were independent of E_h over the range 100–300 mV, and were similar to the kinetics observed in unextracted chromatophores at high E_h (200–300 mV). At $E_h > 380$ mV, a binary pattern of reduction as a function of flash number was seen (see later). The results were interpreted as showing that QH_2 produced at the Q_B site on the reaction center was able to diffuse to its site of oxidation on the ubiquinol oxidase complex; this would be the site putatively occupied by Q_Z , which we may refer to as the Q_Z site. Such a diffusion limited reaction requires that at both the Q_B and Q_Z sites, the ubiquinol is able freely to equilibrate with the pool. In the light of these results we may suggest that the reaction of the two-electron gate in chromatophores is better described by the following set of reactions:

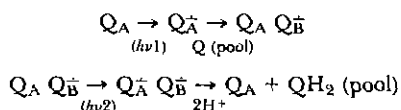

Extraction of the quinone pool did not eliminate the stimulation of the flash-induced Cyt *c* oxidation seen after addition of UHDBT, showing that electron transfer from RFeS is independent of the quinone pool. Further discussion of the mechanism of the ubiquinol-cyt c_2 oxidoreductase is deferred to Section VII,F in which a general Q-cycle model is presented.

F. Reductants for Cytochrome b_{561}

The nature of the reactions of the secondary quinone (Q_B) involved in the two-electron gate by which electrons are transferred from the reaction center to the chain has been discussed earlier. The functioning of the gate has also been observed in chromatophores (Fowler, 1976; Barouch and Clayton, 1977; de Grooth *et al.*, 1978). A binary pattern in the extent of reduction of Cyt b_{561} (E_{m7} of +50 mV) has recently been shown as a function of flash number from the dark state; this suggests that electrons are available to reduce this Cyt b_{561} only after Q_B has been fully reduced (Bowyer *et al.*, 1979). The redox dependence of the operation of the gate in chromatophores when low concentrations of mediators are used suggests that in a fraction of centers ($\sim 50\%$), $Q_B H \cdot$ or Q_B^- is present at redox potentials much higher than the E_{m7} for the couple $Q_B^-/Q_B H$ found by Rutherford and Evans (1979, 1980). This

suggests a mechanism which allows $Q_B\dot{H}$ (or $Q_B^{\dot{-}}$) to exist out of equilibrium with the chain, so that experiments performed in the redox range $300 > E_h > 100$ mV, using mediators at concentrations $< 10 \mu M$, probably involve a heterogeneous population of chains in which a fraction of reaction centers (those with $Q_B\dot{H}$) pass two electrons to the chain on flash excitation, and a fraction (those with Q_B oxidized) pass no electrons to the chain. In support of this possibility, Bowyer and Crofts (1981) have shown that in this E_h range, ametryne at $100 \mu M$ blocks electron transfer from $Q_A^{\dot{-}}$ in about half of the centers, but has no effect on Cyt b_{561} reduction. R. Stein and C. A. Wraight (personal communication) have shown that in reaction centers, ametryne, like *o*-phenanthroline (Vermeglio *et al.*, 1980b; Wraight and Stein, 1980), blocks electron transfer from Q_A^- to Q_B , but not to $Q_B^{\dot{-}}$. Such an effect in chromatophores would account for the observation leading to the hypothesis of heterogeneous chains outlined earlier.

G. Role of Cytochrome b_{566}

It has been possible to obtain precise spectra of the three *b*-type Cyts of *Rp. sphaeroides* in the α -band region, and to select wavelengths of measurement appropriate for the kinetic resolution of the redox changes of the individual Cyts on flash excitation. It had previously been thought that Cyt b_{561} was the only *b*-type Cyt undergoing rapid redox changes during operation of the cyclic chain (Crofts and Wood, 1978; Dutton and Prince, 1978b). It has now been shown that in the presence of antimycin, Cyt b_{566} (E_{m7} of -90 mV) is reduced rapidly following flash excitation (Bowyer *et al.*, 1981a; Crofts *et al.*, 1982a).

The kinetics of reduction of Cyt b_{561} and Cyt b_{566} in the presence of antimycin are of interest. Reduction of both cytochromes is strongly dependent on ambient redox potential (E_h). At values of E_h above 180 mV (at pH 7), Cyt b_{561} goes reduced following a flash with a $t_{1/2} \sim 7$ msec, but after a lag of 0.5–1 msec. As the redox potential is lowered, the rate of reduction increases, to give a $t_{1/2} \sim 300 \mu\text{sec}$, and the lag becomes shorter ($\sim 200 \mu\text{sec}$); these effects titrate in with an apparent $E_{m7} \sim 120$ mV (Evans and Crofts, 1974b; Bowyer and Crofts, 1981). Under these conditions ($E_h \sim 80$ mV), the time course of reduction of Cyt b_{561} , including the lag phase, gives rise to 90% reduction in ~ 1 msec, indicating a kinetic pathway considerably faster than that measured at this E_h for electron transfer through the antimycin sensitive site to the high potential components (RFeS, Cyt c_1 , Cyt c_2) of the chain in the absence of antimycin ($t_{1/2}$ 1–2 msec). The kinetics of Cyt b_{566} are more difficult to measure because of the broad, double α -band, and

overlap with the sharper bands of Cyt b_{561} and the two *c*-type Cyts. When Cyt b_{561} is chemically reduced before flash activation, rapid reduction of Cyt b_{566} ($t_{1/2} \sim 0.4\text{--}1.5$ msec, lag < 100 μsec) can be readily observed in the presence of antimycin.

When Cyt b_{561} is oxidized ($E_h > 60$ mV) before flash excitation in the presence of antimycin, Cyt b_{566} changes following a single flash are much smaller, perhaps indicating transient reduction followed by oxidation. However, a fuller reduction of Cyt b_{566} can be readily observed if a second flash occurs before Cyt b_{561} goes reoxidized. In the absence of antimycin at values of E_h between 0 and 50 mV where Cyt b_{561} is chemically reduced, flash excitation leads to oxidation of Cyt b_{561} with $t_{1/2} \sim 2$ msec after a lag of 500 μsec . Rather surprisingly, the Cyt b_{561} remains partly oxidized for tens of milliseconds, although both the ambient E_h and the presence of photoreductant in the acceptor pool would be expected to favor rapid rereduction. Following a second flash, Cyt b_{561} goes transiently reduced then reoxidized. Over this E_h range Cyt b_{566} goes transiently reduced then oxidized following excitation by one or two flashes.

These results are most easily interpreted in terms of an electron transfer chain in which Cyt b_{566} accepts electrons from a donor, and passes them to Cyt b_{561} in a simple linear chain. Antimycin inhibits the oxidation of reduced Cyt b_{561} . As will be discussed later, it seems likely that the donor is ubiquinol from the pool, which is oxidized in a concerted reaction in which one electron is passed to Cyt b_{561} and the other to FeS^+ in a Q-cycle mechanism. Crofts *et al.* (1976, 1977) had previously pointed out that the relative kinetics of reduction of Cyt b_{561} and Cyt($c_1 + c_2$) (see earlier) were incompatible with a *simple* Q-cycle mechanism, since Cyt b_{561} appeared to undergo reduction faster than Cyt($c_1 + c_2$). This apparent discrepancy has been resolved by a number of modifications to the original Q-cycle mechanism, and by incorporation of the new information on components and their kinetics reviewed briefly earlier. Crofts and Meinhardt (1982) and Crofts *et al.* (1982b) have suggested a Q-cycle model to account for the kinetic and thermodynamic behavior of the cyclic chain of *Rps. sphaeroides*, which is summarized in Figs. 6 and 7. The model is discussed in greater detail later.

VI. The Electron Donors to P700 and P870

The general nature of the sequence of electron donors to P700 and P870 now appears to be similar. This sequence is $[\text{FeS}] \rightleftharpoons [\text{bound } c] \rightleftharpoons [“\text{loose” } c \text{ or PC}] \rightleftharpoons \text{P}$, where P denotes the reaction center in the plant or

FIG. 6. The components of the cyclic electron transport chain of *Rp. sphaeroides* shown against a redox scale. The components in the dashed box are thought to belong to the ubiquinol–Cyt c_2 oxidoreductase complex. The rectangles against each component are centered at the midpoint potential (E_m) and extend over the redox range in which the components are between 90% oxidized and 90% reduced. The dotted rectangle around Q_b (the bulk ubiquinone) represents the redox range over which the oxidized and reduced forms would be present at a stoichiometry of $\geq 1/\text{complex}$. The dotted rectangles above and below Q_z show guesses at the midpoints of the couples Q_z/Q_zH^+ (lower E_m) and Q_zH^+/Q_zH_2 (higher E_m) (see Crofts *et al.*, 1982a). Q_I and Q_{II} correspond to Q_A and Q_B of the text.

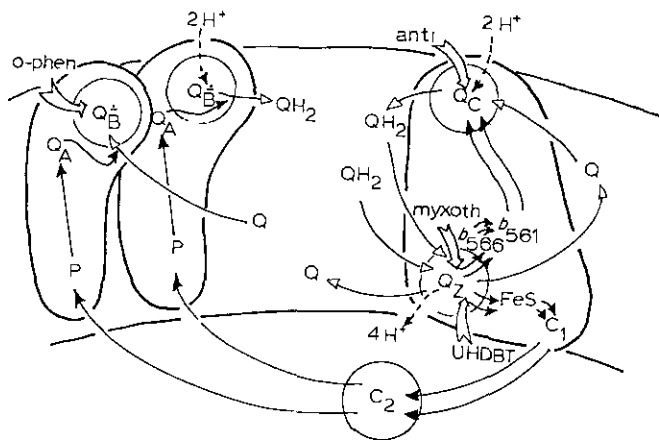
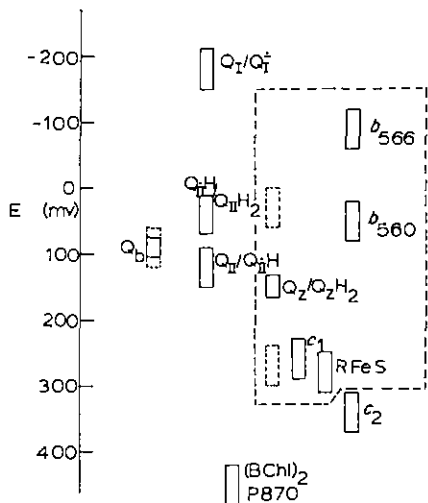

FIG. 7. A scheme for the electron transport chain of *Rp. sphaeroides*. The scheme shows the ubiquinol–Cyt c_2 oxidoreductase arranged as a Q cycle so as to act as a two-electron transferring complex. In half the reaction centers Q_B^+ is reduced to QH_2 , and two electrons are delivered to each complex. In the other half, the secondary acceptor (Q_B) is reduced to the stable semiquinone anion (Q_B^-), and no electrons are delivered to the chain. The stoichiometry of components is thought to be 0.5 complex/RC, and the net stoichiometries of reactants are one electron transferred and $2 H^+$ transported per reaction center activated (Crofts *et al.*, 1982b). Closed arrows show electron transfers, open arrows show chemical transitions. Anti refers to antimycin, myxoth refers to myxothiazole, and o-phen refers to o-phenanthroline. Broad arrows show sites of binding and inhibition. See Section VII,G for further explanation.

bacterial system (see V,E for application to chromatophores already mentioned and V,C for discussion of complexities regarding Cyt *f* in this scheme). The presence of the membrane-bound *c*-type Cyt, Cyt *f*, in algae was first shown in *Chlamydomonas* (Wood, 1977). Such a Cyt has now been purified from several other green and blue-green algal sources (Table I) and from chromatophores (Wood, 1980, 1981). The acceptor of electrons from the membrane-bound *c*-type Cyt and the immediate donor to the reaction center Chl or bacteriochlorophyll (BChl) protein is a heme or copper protein that has been called a "distributive" carrier (Bendall, 1977; Velthuys, 1980a). Algae such as *Chlamydomonas* (Wood, 1978), *Anabaena variabilis* or *Porphyridium boryanum* can utilize either the *c*-type Cyt or the copper protein plastocyanin, dependent upon the metal content of the growth medium. *Euglena* and the xanthophyceae *Bumiltriopsis filiformis* do not contain plastocyanin (Bohner and Böger, 1978). The environmental importance of flexibility in synthesis of this loosely bound protein has been discussed by Wood (1978), who pointed out that copper would tend to precipitate as the insoluble sulfide under reducing conditions and iron would tend to be insoluble as ferric hydroxide under oxidizing conditions. Such a redox duality is not uncommon, since it is also known to occur between Cu and Fe oxidases in bacteria and at the level of ferredoxin-flavodoxin in algae. The inference that plastocyanin is a mobile or distributive carrier is based upon the following observations.

1. Cytochrome *f* can be present in shade plants at a stoichiometry of $<1/P700$, and as low as $\sim 0.5/P700$ (Boardman *et al.*, 1975).
2. Plastocyanin appears to be present in the electron transport chain in excess of Cyt *f*, with the ratio of PC:*f* in spinach chloroplasts estimated to be equal to 4–5 (Plesnicar and Bendall, 1970), or approximately 2 from the earliest estimate (Kato *et al.*, 1962) and by an *in situ* flash spectrophotometric assay (Haehnel, 1977).
3. The increased rate of P700 reduction caused by higher osmolarity has been interpreted in terms of a concentration effect on plastocyanin free within the thylakoids that can react with P700 (Haehnel *et al.*, 1980). This plastocyanin reduces P700 with characteristic half-times of approximately 200 and 20 μsec , the latter time associated with a complex between plastocyanin and P700 (Haehnel *et al.*, 1980). The redox reactions of plastocyanin with P700 and Cyt *f* can now be interpreted in terms of the X-ray crystal structure of plastocyanin (Colman *et al.*, 1978). Briefly, this structure shows the copper to be coordinated at one end of a "barrel" structure to two histidines, a cysteine, and a methionine (Fig. 1B). The closest approach of solvent to the copper, blocked

only by one of the histidine ligands, is about 6 Å. One electron transfer pathway could utilize this path. Because negatively charged side chains are absent from this region, it appears particularly favorable for reactions with negatively charged inorganic reductants and oxidants such as ferro- and ferricyanide. Another electron transfer pathway could be the hydrophobic channel lined with five aromatic residues, which are invariant in all plant plastocyanins. The stimulation by high ionic strength of electron transfer from plastocyanin to P700 implies that this reaction is associated with the former pathway, whereas the reaction with Cyt *f*, whose oxidation is inhibited by high ionic strength, may be associated with the latter hydrophobic pathway (Haehnel *et al.*, 1980).

The osmolarity experiment mentioned earlier serves to introduce the problem of plastocyanin position in the membrane, which has been controversial. Since there is no knowledge of the conformation of this protein in membranes, it is important to note that the crystal structure studies of Colman *et al.* (1978) show plastocyanin (in the crystal) to be a slightly flattened cylinder or barrel of dimensions $40 \times 32 \times 28$ Å. Stood on end, in a direction perpendicular to the plane of the membrane, a plastocyanin molecule of this size would span about one-half the chloroplast bilayer membrane thickness. Two plastocyanins stacked end-to-end would just about span the membrane. The crystal structure, in addition, emphasizes that measurement of Cu atom accessibility may not give the same result as measurement of protein reactivity. Unfortunately, not even this structural distinction serves to sort out the disagreement in the literature. The kinetic experiments strongly imply that the functional site of PC \rightarrow P700 electron transfer is at the inside of the membrane, with a degree of mobility of at least part of the PC pool indicating a loose attachment to the membrane. Some workers find that plastocyanin is inaccessible to antibody (Hauska *et al.*, 1971), which is consistent with the interpretation of the osmolarity experiment (Bendall and Wood, 1978; Haehnel *et al.*, 1980), whereas others have obtained opposite results (Böhme, 1978). Inhibition of electron transport at the site of the negatively charged plastocyanin by polycations (Brand *et al.*, 1972) and mercuric ion (Kimimura and Katoh, 1972), and labeling of the protein by the membrane impermeant probe diazobenzenesulfonate (Smith *et al.*, 1976) imply accessibility of the protein at the outer aqueous phase of the membrane. Inhibition of electron transport by the more lipid-soluble HCN, which is thought to specifically react with the copper, does not imply anything about the Cu location in the membrane, al-

though inaccessibility to a Cu chelator (Plesnicar and Bendall, 1973) and to ferrocyanide (Whitmarsh and Cramer, 1979a) implies an internal location. It would appear that the data point to an internal location of the copper. The main disagreement concerns whether or not a fraction of the PC protein pool is accessible to the outer aqueous phase. The most common topographical position of plastocyanin depicted in the chloroplast membrane is on the inside (Fig. 8), which is consistent with most chemiosmotic models of the electron transport chain and is consistent, in any case, with data on the position of the copper.

VII. Vectorial Electron Transport

A. Background

The early models of Mitchell on the mechanism of vectorial electron transport and proton translocation included a role for the quinol (QH_2)–quinone (Q) couple acting as the intermediate transmembrane shuttle of H atoms (Mitchell, 1966). The model for mitochondria proposed three proton–electron loops to span the three sites of H^+ translocation responsible for the ATP:O ratio of 3 from $\text{NADH} \rightarrow \text{O}_2$. A problem with this model was that the mitochondrial electron transport chain did not divide readily into alternating H and e^- carriers. The most obvious separation of the carriers was into low and intermediate poten-

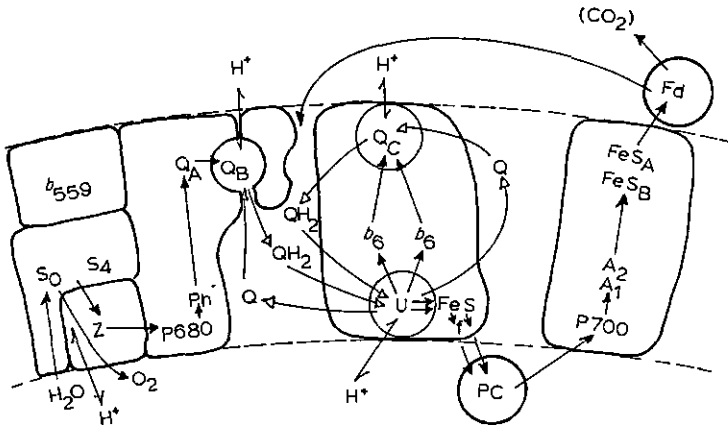

FIG. 8. The chloroplast electron transfer chain. The scheme shows the chain arranged as three Mitchellian proton pumps in series, with the plastoquinol-plastocyanin oxidoreductase acting through a Q cycle. The overall stoichiometry is one electron transferred and three protons pumped for a single turnover of both reaction centers.

tial hydrogen carriers and high potential ($c_1 \rightarrow c \rightarrow$ oxidase) electron carriers. One major problem for the loop model was then to identify the H carrier operating toward the high potential end of the chain. It was suggested by Mitchell (1976) that the middle and high potential segment of the respiratory chain might use the two ubisemiquinone couples arranged in a "Q loop" in order to provide the appropriate stoichiometry of proton translocation. A linear scheme using the separate semiquinone couples was proposed by Crofts *et al.* (1975a).

Models for the vectorial arrangement of the electron transport chain in plant and bacterial photosynthesis have previously been reviewed in the literature (Crofts, 1974; Trebst, 1974; Hauska and Trebst, 1977; Crofts and Wood, 1978; Dutton and Prince, 1978b; Witt, 1978). An early model of the proton translocating electron transport chain for chloroplasts assumed two sites of proton deposition to the membrane inner space in the noncyclic chain, one provided by the water-splitting reactions in PSII (see Wydrzynski, Chapter 10, this volume) and one by a plastoquinone shuttle operating between the two photosystems. It was suggested that the plastoquinone shuttle could also be used for PSI cyclic electron transport. This suggestion was based partly on analogy with the presumed function of ubiquinone in the cyclic system of the bacteria, although it had been recognized that the slower phases of electron transport contributed an electrogenic process in addition to that associated with charge separation in the reaction center (Jackson and Crofts, 1971).

These early models made the following assumptions as first approximations.

1. In chloroplasts and many photosynthetic bacteria, transmembrane electron transfer occurs in the primary photoacts (see Witt, 1975, 1979). Both photosystems are electrogenic in chloroplasts.

2. Plastoquinone and ubiquinone, which are present in stoichiometric excess in the membrane (~ 10 – 40 quinones/reaction center) have sufficient mobility in the direction perpendicular to the membrane surface so that they can be carriers of hydrogen equivalents from one side of the membrane to the other in a hydrogen shuttle.

3. In the case of the second site of proton deposition in the chloroplast system, centered around the water-splitting system, it was initially assumed that proton release and transfer occurred cooperatively, along with O_2 production, with four protons being released on every fourth electron transfer event at the PSII reaction center (cf. Joliet and Kok, 1975).

4. In chromatophores an electrogenic event associated with the dark electron transfer of the cyclic chain was also characterized (Jackson and

Crofts, 1971; Jackson and Dutton, 1973; Evans and Crofts, 1974a). From the sensitivity to antimycin, the redox dependence, the effects of uncouplers and ionophores, and a comparison with electron transfer events, it was concluded that this electrogenic process was associated with electron transfer through the antimycin sensitive site. Crofts *et al.* (1975a) suggested that the electrogenic process was the oxidation of Cyt b_{561} .

These simple models have had to be considerably modified (see Figs. 7 and 8) in the light of more recent research, and some of the underlying assumptions have been shown to be oversimplifications. These developments will be discussed later in the context of the individual proton pumps and of general properties of redox centers involved. (Also see Junge and Jackson, Chapter 13, this volume.)

B. Mechanism of the Carotenoid Spectral Shift

The response of the carotenoid molecules to an electrical field across the membrane in which they are situated is somewhat variable. Most commonly, an absorbance change interpretable as a red shift of the spectrum is observed, as is the case in *Rp. sphaeroides* and *Rp. capsulata*, although it has been pointed out that the change in *Chr. vinosum* is a blue-shift of the carotenoid spectrum (Bowyer and Crofts, 1980). It has also been suggested that in some cases the chloroplast carotenoid change measured at 515 nm may contain a blue-shifted component (Schapendonk, 1980). The most widely accepted view of the carotenoid spectral shift is that it represents an electrochromic or Stark effect, a perturbation of molecular energy levels caused by the light-induced transmembrane electrical field. The magnitude of this field across the 50-Å insulating phase of the membrane is typically 2×10^5 V/cm. Because of the usefulness of the carotenoid shift as an indicator of membrane potential, much effort has gone into attempts to understand in detail the mechanism of the shift. Over the past few years, a plausible molecular mechanism has been formulated as a result of work in a number of laboratories. In order to understand this mechanism, it is necessary to briefly outline salient features of the basic theory underlying the electrochromic shift and those characteristics of the carotenoid change that made a simple theory inadequate. A more detailed discussion of the basic theory is available elsewhere (Labhart, 1967; Liptay, 1969; Reich and Schmidt, 1972; Wraight *et al.*, 1978; also see Junge and Jackson, Chapter 13, this volume).

Wavelength changes in light absorption occur in strong electric fields because the energy of the electronic transition from ground to excited

state associated with absorption of light is altered by the field. The change in the energy of the transition is a consequence of differential effects of the field on the energy of ground and excited states due (a) to different permanent dipole moments of ground and excited states; and (b) to a difference in polarizability of ground and excited states, resulting in a difference in the magnitude of the induced dipole moments. The change in transition energy is seen as a shift, $\Delta\lambda_m$, of the absorbance maximum. A somewhat simplified equation describing these effects is given here:

$$\Delta\lambda_m = \frac{\lambda_m^2}{hc} (\mu_g - \mu_e) \cdot E + 1/2(\alpha_g - \alpha_e)E^2$$

Where λ_m is the absorption peak (cm) in the absence of the field, h is Planck's constant (6.63×10^{-27} erg-sec), c is the speed of light (3×10^{10} cm/sec), $(\mu_g - \mu_e)$ is the difference between the permanent dipole moment in the ground and excited states (esu charge units), $(\alpha_g - \alpha_e)$ is the difference between the polarizability of ground and excited states (cm^3), and E is the electric field (esu volt units). The value of $\Delta\lambda_m$ calculated from typical values of the variables is on the order of a few tenths of a nanometer (Wraight *et al.*, 1978).

The equation shows that for molecules with a permanent dipole, the main effect will be a *linear* shift in the absorbance maximum to the red with change in field strength. For molecules with no permanent dipole, the main effect will be a *quadratic* relationship between extent of shift and field strength arising from a linear effect of the field on the induced dipole $(\alpha_g - \alpha_e) \cdot E$, which results from the polarizing effect of the field. The dot products contain the dependence on the angle between the permanent dipole and that of the field.

Of the pigment molecules known to undergo spectral shifts associated with generation of an electric field across the membranes of chloroplasts and chromatophores, the chlorophylls have a permanent dipole and might therefore be expected to show a linear shift; the carotenoids have no permanent dipole but are polarizable, and might therefore be expected to show a quadratic shift. In all cases where sufficiently accurate measurements have been made, under conditions close to physiological, all pigments *in situ* show a linear shift with applied field (but see de Grooth *et al.*, 1980a, b, for experiments showing quadratic effects at high fields). The discrepancy between the expected and observed behavior of the carotenoids (which contribute the major electrochromic change in the visible region) has been a subject of much discussion. A plausible hypothesis to explain the discrepancy has been proposed by Reich and Schmidt (1972). They have suggested that the carotenoid molecules,

which respond to the field, are contained in an environment in which they experience a strong local field (E_l). The effect of this would be to polarize the molecules, giving them an induced dipole, $(\alpha_g - \alpha_e) E_l$, and shifting the spectrum to the red by $(\alpha_g - \alpha_e) E_l^2$. A small additional field from the membrane potential (E_m) would then give rise to an additional linear shift $(\alpha_g - \alpha_e) E_l \cdot E_m$, the sign of which would depend upon the relative orientation of E_l and E_m .

C. Characteristics of the Carotenoid Shift in *Rp. sphaeroides*

Vredenberg and Ames (1967) noted that the spectrum of the carotenoid change induced by illumination could be accounted for by a small shift to the red of the absorbance spectrum. However, they also mentioned two peculiarities of the change that were of great significance: (1) the point at which the difference spectrum crossed the zero-line was ~ 10 nm to the red of the peak of the absolute spectrum of the carotenoids; and (2) this point did not appear to change markedly as the amplitude of the absorbance change varied. The authors pointed out that such a difference spectrum could not be accounted for by a *progressive* shift to the red of the bulk carotenoid absorbance spectrum.

These original observations have been confirmed and extended by work in a number of other laboratories, and since the nature of the spectral change was contrary to that expected from simple electrochromic theory, attempts have been made to refine the measurements in order to determine more precisely the constraints within which any hypothetical mechanism must operate. It was shown by Crofts *et al.* (1975) and Holmes and Crofts (1977) that, when the spectrum of the change induced by a series of single turnover flashes was measured close to the point of zero change, a small but clearly resolved progressive shift to the red in the isosbestic point could be seen on successive flashes. The change represented a shift of ~ 0.7 nm. When attempts were made to measure the shift using continuous illumination or diffusion potentials, no progressive change could be detected within the resolution of the apparatus (~ 0.3 nm). One difficulty in all such measurements has been the need to correct for changes that are not part of the electrochromic spectrum. In the spectra of flash-induced changes, such a correction can be made by subtracting contributions that are insensitive to electrophoretic ionophores such as valinomycin and gramicidin. When the spectral changes are induced by continuous light, the quantum yield of the electrochromic changes is much greater than that of the changes due to redox centers, so that at low light intensities the contribution of the

latter is small. De Grooth and Amesz (1977a, b) found that chromatophores illuminated at subfreezing temperature in the presence of a redox catalyst (phenazine methosulfate) showed an unusually large carotenoid change with a negligible contamination from redox center changes. In these experiments, they were able to demonstrate a convincing shift to the long wavelengths, which was proportional to the change in amplitude of the difference spectrum but which had its initial inflection point several nanometers towards the red of the main absorption band. They interpreted their results as showing that the carotenoid undergoing a change had a spectrum shifted to the red with respect to the absorption maximum of chromatophores and that the bulk spectrum was due to overlapping contributions from the red-shifted population and a population with a λ_{\max} to the blue of the bulk spectrum, which contributed a negligible change in the spectrum in the presence of a field.

The two hypotheses outlined earlier—that of R. Reich and colleagues postulating a local permanent field to explain the linear shift with applied field, and that of J. Amesz and colleagues postulating that in *Rp. sphaeroides* the carotenoid change comes from a red-shifted population—provided a plausible rationale for the behavior of the carotenoid change and, by extension, that of the electrochromic responses of other pigments. These hypotheses are to some extent complementary, since the Reich hypothesis predicts that for the carotenoids, the population undergoing change should be red-shifted with respect to the nonresponding population.

These hypotheses have received strong support from a number of observations. Two different proteins in *Rp. sphaeroides* and *Rp. capsulata* are associated with binding the light-harvesting pigments, B800, B850 and B870 where the numbers refer to the λ_{\max} values (in nm) for the Bchl components. Details of the peptide and pigment compositions are reviewed by Cogdell and Thornber (1980). In carotenoid-containing strains, both pigment-protein complexes contain one carotenoid molecule per complex.

1. Scolnick *et al.* (1980) have isolated mutant strains of *Rp. capsulata*, each of which contains only one or the other of the two complexes. The strain with B870 has a carotenoid spectrum which peaks to the blue of the spectrum of wild-type strains and shows no electrochromic response; the strain with B800, B850 has a carotenoid spectrum which peaks to the red of the wild-type spectrum and shows electrochromic changes.
2. Broglie *et al.* (1980) have separated the two complexes by SDS-gel

electrophoresis. The complexes retain their pigments, with spectra close to those in situ. The isolated B800, B850 complex shows a red-shifted spectrum and the B870 complex shows a blue-shifted spectrum.

3. Holmes *et al.* (1980) and Matsuura *et al.* (1980a) have shown that the amplitude of the carotenoid change is proportional to the amount of B800, B850, when this is varied by growth at different light intensities.
4. Webster *et al.* (1980a, b) have shown that mild treatment with pronase selectively modifies the B800, B850 complex leading to a loss of carotenoid response and a loss of the 800 nm BChl band. These four observations show that the carotenoid responding to the field is that of the B800, B850 complex and that it has the properties expected from the hypothesis.
5. As noted earlier, Bowyer and Crofts (1980) have shown in *Chr. vinosum* an electrochromic blue shift of a long wavelength carotenoid component.

Peak values of the transmembrane potential in chromatophores measured by the carotenoid absorbance change have been estimated to be as large as 400 mV, with the inside of the vesicle positive. It has been demonstrated that changes of membrane surface potential contribute to the electrochromic shift under conditions of low ionic strength (Symons *et al.*, 1979; Matsuura *et al.*, 1980b). Under these conditions, care should be taken, and changes of surface potential taken into account, when calibrating the electrochromic absorbance change using the dark-diffusion potential method of Jackson and Crofts (1969).

D. Electrogenic Events Indicated by Electrochromic Changes

In *Rp. sphaeroides*, *Rp. capsulata*, and *Rs. rubrum*, the photochemical reaction is electrogenic, contributes 60–70% of the total fast electrochromic absorbance change and is therefore inferred to span 60–70% of the membrane dielectric phase (Dutton and Prince, 1978b; Wraight *et al.*, 1978). Reduction of P870⁺ by Cyt *c*₂ contributes an additional 30–40% of the electrogenic phase. In *Chromatium*, and possibly in *Rp. viridis*, the photochemical reaction appears to span a much smaller fraction of the dielectric because it contributes little, if any, to the carotenoid change (Case and Parson, 1973). Reduction of the oxidized reaction center in the former organism by one of the bound *c*-type Cyt appears to be the main electrogenic process linked to the photochemical events.

In early studies on chloroplasts, the electrogenic events of the photoreactions were shown to occur with a $t_{1/2} \leq 20$ nsec. However, this half-time could include a contribution from the rapid reduction of P680⁺ by the rapidly reacting secondary donor Z₁ with $t_{1/2} = 30$ nsec (van Best and Mathis, 1978). It had been shown that hydroxylamine treatment, which inhibits electron transfer from Z₁ (den Haan *et al.*, 1974), substantially reduces the amplitude of the electrogenic process (Joliot and Joliot, 1976). More recently, the rise kinetics of the 515 nm absorbance change in chloroplasts have been shown to be faster than 10 nsec in the presence of ferricyanide (which oxidizes P700 and eliminates PSI-linked changes) and Tris (which disconnects the O₂-evolving enzyme). Under these conditions the half-time of P680⁺ reduction was 6 μsec. Since no phase corresponding to this reduction was seen in the 515 nm change, Conjeaud *et al.* (1979) inferred that the light reaction of PSII must be electrogenic.

E. The Slow Electrochromic Phase in Chloroplasts and Algae

The slow phase of the electrochromic response (Witt and Moraw, 1959; Joliot and Delosme, 1974; Joliot *et al.*, 1977; Horvath *et al.*, 1979) has been attributed to electrogenic electron transfer outside the photochemical reaction centers (but see Vredenberg, 1981, for an alternative point of view). A number of laboratories have studied the relation between the slow phase, proton uptake and release, electron transfer reactions, cyclic and noncyclic pathways, redox potential, and electrical and chemical components of the proton gradient.

The slow electrochromic phase seen in *Chlorella* and *Chlamydomonas* by Joliot and Delosme (1974) was associated with system I because it was unaffected by treatment with hydroxylamine and DCMU, which inhibits PSII and substantially diminishes the amplitude of the fast phase. Early action spectra of a slow 515 nm absorption change in *Chlorella* had indicated that it was caused by both PSI and PSII (Govindjee and Govindjee, 1965). Based on inhibition of the slow electrochromic phase in algae by antimycin A and lack of it in chloroplasts shocked without Mg²⁺ and ferredoxin (absence of cyclic phosphorylation), it has been concluded that this phase may be driven by reactions associated only with PSI cyclic electron flow (Hind *et al.*, 1981).

It appears that the slow phase can also be driven by electron flow from PSII because (a) it can be observed under aerobic conditions in broken chloroplasts without ferredoxin (Velthuys, 1978), which do not

sustain cyclic phosphorylation; and (b) it shows a two-flash periodicity, though of small amplitude (Bouges-Bocquet, 1980a; Velthuys, 1980b), which is characteristic of components requiring electron flow through the secondary acceptor gating component, Q_B , described earlier. The other properties of the slow phase are as follows.

1. The time course of its rise is approximately correlated with that of reduction of Cyt *f* and b_6 after a flash (Bouges-Bocquet, 1977; Crowther and Hind, 1980).

2. The slow phase is inhibited by the quinone analog, DBMIB. The latter fact has been used to infer involvement of plastoquinone in the generation of the slow phase, but it would also appear to indicate that the FeS center, the probable site of action of DBMIB (Malkin, 1981b), is involved in the pathway generating the slow phase.

3. Although the amplitude of the slow phase under optimal conditions can be equal to that of the fast electrochromic change, the slow phase is also strongly inhibited after several closely spaced flashes (Bouges-Bocquet, 1977). By varying the conditions of coupling and redox poise, at least two possible reasons for this inhibition have been identified. (a) It has been inferred that the H^+ electrochemical potential, $\Delta\bar{\mu}_{H^+}$, acts to inhibit formation of the slow phase (Bouges-Bocquet, 1981b). This would imply that the slow phase only occurs when the light intensity is low or $\Delta\bar{\mu}_{H^+}$ is small for other reasons. (b) The redox poise of components constituting the electrogenic reaction is critical, as discussed later.

4. Its amplitude is dependent on ambient redox potential. In *Chlorella*, the slow phase is readily observed on the flash illumination at low frequency of dark-adapted cells under normal aerobic conditions. Bouges-Bocquet (1981b) has pointed out that the PQ pool is about 12% reduced under these conditions, whereas the amplitude of the slow phase is 80% of the maximal value obtained on adding reductant. Under more oxidizing conditions, the slow phase is diminished in extent. These results suggest that the slow electrogenic process requires prereduction of a component (U) with an E_m about 40 mV more positive than that of the bulk PQ (i.e., E_{m7} for U/UH₂ would be ~120 mV or ~160 mV, depending on the value chosen for the E_{m7} of the pool). Crowther and Hind (1980) reported a requirement for much lower values of the ambient potential ($E_{m8} \approx -54$ mV); however, these results were obtained in experiments with repeated flashes at relatively short intervals (2 Hz). More recently, D. Crowther (personal communication) has measured a value for the potential dependence closer to that estimated by B. Bouges-Bocquet, under conditions in which a longer dark time was al-

lowed between flashes. It appears therefore that (a) U has to be reduced before a flash if the slow phase is to be seen; and (b) when successive flashes are used, reduced U has to be regenerated between the flashes. In chloroplasts, U is reduced rapidly at low potential ($E_h < -54$ mV). U has many of the properties of the component Q_z of the bacterial cyclic chain (see later) and, by analogy, is probably a bound plastoquinone. However, the arguments that suggest that the Q_z site is in rapid equilibrium with the pool can be applied as well to the relation between U and the pool (Fig. 8).

5. Both cyclic PSI and noncyclic PSII may be involved in the slow phase. In *Chlorella*, or with chloroplasts incubated under moderately reducing conditions, the slow phase can be readily observed on repeated flashes in the presence of DCMU, suggesting that the cyclic pathway around PSI is competent to drive the extra loop. It seems likely that the physiological electron donor to the cyclic chain is ferredoxin and that the cycle becomes operative when reduced ferredoxin accumulates (Krause and Heber, 1976; Crowther *et al.*, 1979; Mills *et al.*, 1979). Perhaps more surprising has been the observation mentioned earlier, made independently by Velthuys (1980b) and Bouges-Bocquet (1980a), that in the absence of DCMU the slow phase shows a binary pattern in the amplitude of the response as a function of flash number from the dark state. These observations seem to show clearly that electrons delivered from PSII through the two-electron gate of Q_B contribute to the reduction of U or, in other words, that the extra proton-pumping loop is physiologically connected to the noncyclic chain. Related observations on the "excess" stoichiometry of proton uptake will be discussed more extensively later.

6. Various Q-loop models for electron transfer reactions giving rise to the slow phase, the $H^+ : e$ ratio of 2, and the related kinetics of turnover of Cyt b_6 and f have been proposed. A role for Cyt b_6 in the slow electrogenic loop has been proposed (Velthuys, 1979; Bouges-Boquet, 1981b; Hind *et al.*, 1981; Olsen and Barber, 1981), although it has been noted that the kinetics of Cyt b_6 reduction appear to be faster than those of the slow electrochromic phase (Slovacek *et al.*, 1980). A frequently occurring feature in these models is the proposal of one-electron donation from plastoquinol (either special or pool PQ) to Cyt f with release of one or two protons to the internal space and generation of a neutral or anionic plastoquinone. The semiquinone would then participate in generation of the slow phase. A number of possible electrogenic processes have been suggested: (a) Oxidation of the semiquinone linked to diffusion of the semiquinone anion toward the outside of the membrane. (b) The oxidation of the semiquinone would occur through an

electrogenic electron transfer pathway, drawn by several authors to include Cyt b_6 . In both of these first two models oxidation of the semiquinone in a Q-cycle-type of mechanism would provide the driving force for the electrogenic process. (c) The semiquinone could be reduced by electrogenic electron transfer from reduced Cyt b in a linear scheme such as that proposed by Crofts *et al.* (1976). (d) Electrogenic H^+ movement could be mediated by a pumping mechanism involving proton channels and/or conformational changes (von Jagow and Engel, 1980; O'Keefe *et al.*, 1981). A general model is shown in Fig. 8, based on a Q-cycle mechanism suggested by Velthuys (1979, 1980a).

F. Vectorial H^+ Translocation—The Role of Diffusible Quinone

Chloroplasts and chromatophores contain bound quinone in the acceptor systems of PSII and P870. From inhibition studies and by analogy with the mitochondrial $b-c_1$ complex, it has been inferred that the analogous complexes in chromatophores also contain bound quinone. The binding site for the latter quinone may be the Rieske FeS center shown to be the site of action of the quinone analogs DBMIB and UHDBT (Fig. 2) acting on chloroplasts and of UHDBT on chromatophores. The question of whether bound quinone is necessary and sufficient to support electron transport, proton translocation, and energy coupling has been raised because of a variety of observations. These include the steric problems involved in visualizing transmembrane quinone motion (Trumpower and Katki, 1979), the fact that the turnover rates of electron transport in chromatophores are competent after extraction of a large fraction of the total quinone (Bowyer *et al.*, 1978; Takamiya *et al.*, 1979), and that the Q pool in chloroplasts is thought to be kinetically incompetent (Bouges-Bocquet, 1981a). As mentioned earlier (Section III,F), recent NMR data indicate that at least in artificial DMPC membrane vesicles, transmembrane movement of UQ-10 headgroups appears to occur at a rate kinetically competent for involvement in steady state electron transfer (Kingsley and Feigenson, 1981). These data would appear to vitiate the objections against such motion (Robertson and Boardman, 1975; Trumpower and Katki, 1979), although the DMPC vesicles did not contain any protein, and the vesicle thickness is somewhat less than that of a real membrane. Kinetic competence of the plastoquinone pool was inferred from the ability of plastoquinone to exchange electrons between as many as 10 chains (Siggel *et al.*, 1972). In addition, reconstitution experiments indicate that it is necessary to incorporate excess ubiquinone into the membrane to obtain physiologically

meaningful rates of phosphorylation (Baccarini-Melandri *et al.*, 1980). These data and the question of the roles of bound versus pool quinone in respiratory and photosynthetic energy transduction have been discussed by Hauska and Hurt (1981).

Further evidence for the role of diffusible plastoquinone, presumably arising from the pool, is derived from temperature studies on cyanobacteria. The fluidity of the membrane, which would specifically influence the rate of reaction of mobile components, can be varied in these organisms because they have a relatively simple lipid and fatty acid composition (Fork *et al.*, 1979; Sato *et al.*, 1979). A broad melting transition dependent upon the temperature of growth has been seen in membranes of *Anacystis nidulans* (Furtado *et al.*, 1979). Noncyclic electron transport in the thermophilic blue-green alga *Synechococcus* sp. is characterized by a nonlinear Arrhenius plot, whereas the Arrhenius plot for electron transport associated with PSI or PSII, which did not include transport through the intersystem plastoquinone, showed a linear Arrhenius plot (Hirano *et al.*, 1981). These experiments were interpreted in terms of a decrease in energy of activation being associated with facilitation of electron transport by a fluid membrane phase, and a specific effect of membrane fluidity on the intersystem plastoquinone. These results are supported by observation of biphasic or triphasic Arrhenius plots for Cyt *f* reduction in *Synechococcus lividus* (Fork *et al.*, 1979). They are perhaps complicated by observation of a biphasic Arrhenius plot for PSII electron transport and PMS- and DCIP-mediated cyclic phosphorylation in *A. nidulans* (Ono and Murata, 1979) and also by reports of biphasic Arrhenius plots centered around 15°–20°C for a variety of energy-linked functions in pea and spinach chloroplasts (summarized in Cramer *et al.*, 1981a). Given the large amount of polyunsaturated fatty acid, as well as the heterogeneity of the lipid and fatty acid, any bulk phase lipid transition should occur only at temperatures much lower than 15°–20°C. However, a small endothermic transition can be detected in spinach chloroplasts near 15°–20°C. A much larger endotherm can be seen in this temperature region in chilling-sensitive tomato chloroplasts (Low *et al.*, 1982).

A caveat for the interpretation of experiments with biphasic Arrhenius plots is that it is sometimes experimentally difficult to be sure that the plot does not have continuous curvature. An alternate interpretation of the latter data is that they result from a negative standard enthalpy of reaction and consequently a continuous decrease, with increasing temperature, of the equilibrium constant of the reaction (Silvius *et al.*, 1978).

G. A Modified Q-Cycle Mechanism

The body of research discussed earlier leads to several conclusions which seem applicable to both green plant and bacterial electron transfer, and which may be summarized as follows:

1. The quinone pool is to a greater or lesser extent involved in transferring electrons from the sites for reduction at the reaction centers, to the sites of oxidation on the quinol oxidase complexes.

2. The quinone reductase sites of the reaction centers (the sites labeled Q_B in Figs. 4, 7, and 8) function as two-electron gates. The sites are relatively freely accessible to quinone and quinol from the pool, and to a variety of inhibitors. The sites are able to stabilize the semiquinone anion species, and when occupied by the semiquinone anion are inaccessible to inhibitors. The proteinaceous environment confers a specificity with respect to inhibitors, and may also determine binding sites for activators (CO_2 , for example, in the PSII complex).

3. The semiquinone species are thermodynamically much more stable at the Q_B sites than in the lipid phase of the membrane ($K_s \sim 1$ compared with $\sim 10^{-10}$ in the membrane). However, the stability constants alone cannot account for the fact that semiquinone anion species are present at relatively high concentration (30–50% of centers) at an ambient E_h higher than the measured midpoint potentials for their formation from quinone. It seems likely that an additional stability is conferred for kinetic reasons—perhaps because, although the semiquinones can be lost by disproportionation, neighboring complexes do not interact, and the concentration of semiquinone in the lipid phase is very low.

4. Although the diffusion coefficients for the native quinones are rather low ($\leq 10^{-9} \text{ cm}^2 \text{ sec}^{-1}$), their relatively high concentration in the membrane allows an adequate current of reducing equivalents to flow between complexes to account for maximal steady state flux.

5. The quinol oxidase complexes are able to oxidize quinol independently of the reaction centers (Hauska and Hurt, 1981; Gabellini *et al.*, 1982). As Garland *et al.* (1975) have pointed out, this observation has important consequences for Q-cycle models. Mechanisms which require that ferrocycytochrome *b* of the complex and a one-electron reductant (the dehydrogenases in mitochondria, the reaction center in photosynthetic systems) cooperate in the reduction of quinone (Mitchell, 1976; Dutton and Prince, 1978b) would be expected to seize up after one turnover when oxidizing quinol in the absence of the coreductant or to switch to an alternate linear mechanism (Mitchell, 1982; Prince *et al.*, 1982b).

6. The quinol oxidase complexes probably operate through Q-cycle mechanisms. A mechanism suggested by Crofts and Meinhardt (1982) and Crofts *et al.*, (1982b) for the operation of the chain in chromatophores from *Rps. sphaeroides* is shown in Fig. 7, and a similar mechanism based on this model and on ideas from Velthuys (1982) and Vermaas and Govindjee (1982) is shown for chloroplasts in Fig. 8.

The models have in common the following features:

1. The complex contains two distinct sites at which quinone and quinol from the pool are able to react.
2. One site (labeled Q_Z) catalyzes a quinol:ferricyt *b*, FeS oxidoreductase reaction in which on oxidation of quinol to quinone, one electron passes to a high potential chain (FeS, cyt c_1 , cyt c_2 , P870 in chromatophores; FeS, cyt *f*, PC, P700 in chloroplasts), and a second electron passes to a low-potential chain containing the *b*-type cytochromes of the complex.
3. The second site (labeled Q_C) catalyzes a ferrocyt *b*:quinone oxidoreductase reaction in which two electrons stored in the *b*-Cyt chain reduce quinone to quinol.
4. In order for the second site to reduce quinone to quinol, two electrons would have to be stored in the *b* Cyt chain. To accomplish this the Q_Z site would have to turnover twice for each turnover of the Q_C site (Garland, 1975; Velthuys, 1982; Crofts *et al.*, 1982b).
5. It is not clear whether the *b*-Cyt chain operates by a series mechanism (Garland *et al.*, 1975; Crofts *et al.*, 1982b) (as suggested in Fig. 7), or by a parallel mechanism (Velthuys, 1980a; Malviya *et al.*, 1980) (Fig. 8), or whether two complexes cooperate so that a dimeric Q_C site accepts one electron from each in the reduction of quinone (a bicycle model!).
6. It seems likely that a semiquinone species is stabilized at the Q_C site [accounting for the stable semiquinone observed by ESR in the mitochondrial complex (Ohnishi and Trumpower, 1980; de Vries *et al.*, 1981)], allowing that site to operate by a mechanism similar to that of the two-electron gate. It is probable that the mechanism of inhibition by antimycin or HOQNO reflects an ability of these inhibitors to displace either quinone or quinol, or both, from the Q_C site. In this context it is tempting to speculate that the redox changes induced by addition of antimycin may in part be due to the loss or gain of electrons, as a semiquinone species is converted to quinone or quinol, by electron transfer to

or from neighboring redox centers, before being displaced from the site by inhibitor (cf. Velthuys, 1982).

7. The reaction at the Q_Z site probably does not involve a semi-quinone with a lifetime significant on the time-scale of turnover of the chain. Since the high-potential and low-potential chains operate at different redox potentials (and, in the case of chromatophores, are maintained at different redox potentials on the time scale of seconds in the presence of antimycin), the Q_Z site does not catalyze a disproportionation reaction on this time scale.
8. The Q_Z site is the site of inhibition by UHDBT and by myxothiazol (Meinhardt and Crofts, unpublished observations; Crofts *et al.*, 1982b).
9. In chromatophores, the electrogenic event indicated by the slow phase of the carotenoid change is linked to the oxidation of the *b*-Cyt (to the oxidation of Cyt b_{561} if the *b*-Cyt are arranged in series).
10. The proton-pumping function of the oxidoreductase would be achieved if the reaction catalyzed by the Q_Z site (center 'o' of Mitchell, 1976) was able to equilibrate with protons only from the inside of the chromatophore or granum [the Cyt c_2 or plastocyanin-containing phase, or P-side (Mitchell, 1976)], whereas the reaction at the Q_C site (center 'i' of Mitchell, 1976) was able to equilibrate with protons only from the outside (N-side).

We discuss in the section below the protolytic reactions which might be attributed to the reactions at these sites.

VIII. Protolytic Reactions

A. General Considerations

The protolytic reactions have been studied directly by observing the rapid pH changes on flash activation, using special pH electrodes (Schwartz, 1968; Fowler and Kok, 1974), or indicator dyes (Chance *et al.*, 1970; Crofts and Jackson, 1970; Cogdell *et al.*, 1972; Ausländer and Junge, 1974; also consult Junge and Jackson, Chapter 13, this volume). A correlation between the rapid pH changes observed and the electron transport processes with which they are associated can be attempted by comparison of kinetics, sensitivity to inhibitors, dependence on redox potential, response to ionophores and uncoupling agents, and so on. Protolytic reactions are in general neutral with respect to phase—the

charge of the proton is compensated in the same phase by the charge of the anion in a weak acid dissociation,

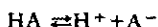

or by an electron in a redox reaction

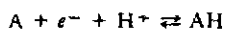

In chemiosmotic proton pumping mechanisms, the pump is electrogenic, so that the electrically neutral protolytic reactions have to be associated with electrogenic reactions operating either in series or in parallel, in which charge is transferred across the insulating membrane separating the two aqueous phases. Much attention has therefore been devoted to the identification of electrogenic processes (as measured by the electrochromic changes discussed earlier, Section VII,8) and their correlation with protolytic and electron transfer reactions. In simple Mitchellian proton pumps, the charge is carried across the membrane in an electrogenic electron transfer; many other models have been suggested in which the electrogenic process is envisaged as movement of different charged species, such as H^+ (or H_3O^+), QH^- , Q^+ , and so on. In all cases, the driving force for the proton pump is, of course, an electron transfer process. In simple Mitchellian pumps, the operation of the pump is a consequence of the involvement of protolytic processes in the electron transfer reactions—the release or uptake of protons on oxidation or reduction of H carriers. The H carriers are envisaged as being mobile across the membrane (see discussion of quinone mobility in Section III,F) and alternating with electron carriers, the latter forming electrogenic arms of proton-pumping loops. In all such schemes, the redox drop (ΔE_{H}) across a neutral H-carrying arm is available to drive and maintain a pH gradient across the membrane, whereas the redox drop across an electrogenic arm is available to drive and maintain an electrical gradient across the membrane (Mitchell, 1966).

B. Chloroplast Photosystem II—Donor Side

It is generally agreed that the release of protons associated with the oxidation of water occurs during the early partial reactions of the water-oxidizing complex rather than in a concerted manner along with the release of O_2 , as originally envisaged (Fowler and Kok, 1974; see reviews by Bouges-Bocquet, 1980b; Velthuys, 1980a; also Wydrzynski, Chapter 10, this volume). However, a major disagreement exists between laboratories as to the pattern of proton release associated with the four step oxidation process. The two major patterns reported are, for the transi-

charge of the proton is compensated in the same phase by the charge of the anion in a weak acid dissociation,

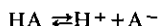

or by an electron in a redox reaction

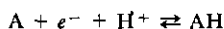

In chemiosmotic proton pumping mechanisms, the pump is electrogenic, so that the electrically neutral protolytic reactions have to be associated with electrogenic reactions operating either in series or in parallel, in which charge is transferred across the insulating membrane separating the two aqueous phases. Much attention has therefore been devoted to the identification of electrogenic processes (as measured by the electrochromic changes discussed earlier, Section VII,8) and their correlation with protolytic and electron transfer reactions. In simple Mitchellian proton pumps, the charge is carried across the membrane in an electrogenic electron transfer; many other models have been suggested in which the electrogenic process is envisaged as movement of different charged species, such as H^+ (or H_3O^+), QH^- , $\bar{\text{Q}}$, and so on. In all cases, the driving force for the proton pump is, of course, an electron transfer process. In simple Mitchellian pumps, the operation of the pump is a consequence of the involvement of protolytic processes in the electron transfer reactions—the release or uptake of protons on oxidation or reduction of H carriers. The H carriers are envisaged as being mobile across the membrane (see discussion of quinone mobility in Section III,F) and alternating with electron carriers, the latter forming electrogenic arms of proton-pumping loops. In all such schemes, the redox drop (ΔE_{H}) across a neutral H-carrying arm is available to drive and maintain a pH gradient across the membrane, whereas the redox drop across an electrogenic arm is available to drive and maintain an electrical gradient across the membrane (Mitchell, 1966).

B. Chloroplast Photosystem II—Donor Side

It is generally agreed that the release of protons associated with the oxidation of water occurs during the early partial reactions of the water-oxidizing complex rather than in a concerted manner along with the release of O_2 , as originally envisaged (Fowler and Kok, 1974; see reviews by Bouges-Bocquet, 1980b; Velthuys, 1980a; also Wydrzynski, Chapter 10, this volume). However, a major disagreement exists between laboratories as to the pattern of proton release associated with the four step oxidation process. The two major patterns reported are, for the transi-

tions $S_0 \rightarrow S_1$, $S_1 \rightarrow S_2$, $S_2 \rightarrow S_3$, and $S_3 \rightarrow S_0$, 1, 0, 1, 2 protons released (Fowler, 1977; Saphon and Crofts, 1977; Velthuys, 1980b) and 0, 1, 1, 2 protons released (Junge *et al.*, 1977). The proton release pattern of 1, 1, 1, 1 has also been reported (Hope and Morland, 1979). These patterns represent conflicting experimental results, rather than conflicting interpretations, and can be resolved only by further experiment. A possible basis for understanding these different results may be provided by the finding that the pattern 1, 0, 1, 2 for H^+ release can be consistently observed after rigorous dark adaptation, whereas the pattern 0, 1, 1, 2 is seen if the chloroplasts are exposed to light before a short dark adaptation (Förster *et al.*, 1981).

In another approach to the above-mentioned problem, Bowes and Crofts (1978) reported a quarternary pattern in the amplitude of the induction curve for 1 msec delayed fluorescence (see review on delayed fluorescence by Govindjee and Jursinic, 1979) emitted by chloroplasts illuminated in the presence of DCMU, with electron donors and acceptors added to catalyze proton-pumping electron transport through PSI. Under these conditions, PSII and its donor pool are limited by the DCMU block to a single electron transfer, so that only one transition of the S states would be expected. By exciting with short flashes from the dark state before addition of DCMU and subsequent illumination in the phosphoroscope, the chloroplasts could be set to a known initial state. The effect of generating a low internal pH, as a result of the H^+ pumping activity of PSI, on the equilibria between the water-oxidizing reactions and the $P680^+ - P680$ couple could then be assessed for known transitions of the S states through the effect on delayed fluorescence, using the rationale of Wraight and Crofts (1971). Using this approach, an enhancement of the delayed fluorescence intensity was observed, which was minimal following 0, 4, or 8 preilluminating flashes, and maximal following 2 or 6 flashes. The general pattern of enhancement was that inferred from the pattern of proton release 1, 0, 1, 2 above (Saphon and Crofts, 1977). However, the relative intensities at the maxima of the induction curves varied by much less than would have been expected from hypothesis, if it were assumed that the redox potentials of the couples involved in each of the partial reactions were similar. It was therefore suggested that at neutral pH the redox potentials of the couples might be in the order (increasing E_{m7}) indicated by the deactivation reactions:

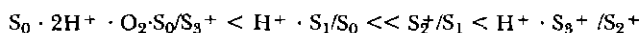

(assuming the pattern of proton release: 1, 0, 1, 2).

At the internal pH in equilibrium with the reactants after H^+ uptake

has reached a maximum, the experimental results suggested that the order might be:

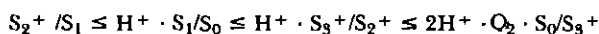

One further line of interest with respect to the pattern of H^+ release is the observation, briefly reported by Bouges-Bocquet (1980b), that the rate of the back reaction,

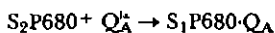

measured by observing the decay of the high fluorescence yield of chloroplasts following a flash from the dark state in the presence of DCMU, is independent of pH. As Bouges-Bocquet has pointed out, the relative rate of this deactivation would be determined by the ratio of rate constants for the reaction between the couples $S_2^+ - S_1$ and $P680^+ - P680$, which is multiplied by the change in proton concentration, if the reaction involved a proton. This observation therefore favors the pattern (1, 0, 1, 2) in which no proton is released in the $S_1 \rightarrow S_2^+$ transition.

Bouges-Bocquet (1980b) reviewed the reactions of the donor side of PSII, paying particular attention to the pathways revealed by kinetic studies over a wide range of temperatures. Figure 9 has been adapted from her suggestion for the most probable relation between components of the donor pool. In only one case has a chemical identity been assigned to a component, Cyt b_{559} , and the physiological role of this component is still something of a mystery. Most other components are identified from secondary kinetic effects on measurable phenomena — P680 kinetics, fluorescence yield rise, delayed fluorescence, glow curves (see Inoue and Shibata, Chapter 11, this volume), oxygen flash yield, H^+ -release, and so on. One other component has a separate kinetic identity, signal II (f or νf), an ESR detectable transient associated with the oxidized form of a secondary donor to P680⁺ (Babcock *et al.*, 1976) and is assumed to be equivalent to Z_2 in the scheme. The kinetic parameters shown on the scheme are taken from literature values or calculated by Bouges-Bocquet (1980b) from thermodynamic and kinetic considerations. The actual values suggested by Bouges-Bocquet (1980b) were chosen to provide an optimal fit in the prediction of the well-characterized α - and β -type hits and misses associated with the damping of the quaternary pattern of oxygen yield on successive flashes from the dark state (Joliot and Kok, 1975; Wydrzynski, Chapter 10, this volume). Examination of the values in the scheme shows that all reactions with donation times greater than $t_{1/2} \sim 100 \mu\text{sec}$ are separated from P680 by at least one intermediate component, so that the kinetic evidence would suggest that the reactions with $t_{1/2} \sim 100 \mu\text{sec}$ for all steps associated with proton release (Junge,

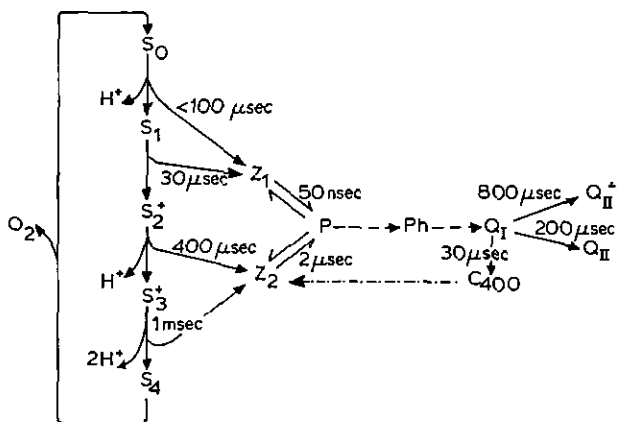

FIG. 9. The donor side of PSII. The scheme is a simplified version of that shown by Bouges-Bocquet (1980b). Component Z_2 gives rise to signals II_{vf} and II_f . Both Z_1 and Z_2 are disconnected from P by treatment at low pH (< 4). Z_1 is disconnected by treatment with Tris. The transition $S_1 \cdot P^+ \rightarrow S_2^+ \cdot P$ gives rise to a broad absorbance change at ~ 320 nm, with $t_{1/2} \sim 30 \mu\text{sec}$, which relaxes with $t_{1/2} \sim 1$ msec on the transition $S_3^+ \cdot P^+ \rightarrow S_0 \cdot P + O_2 + 2H^+$ (Velthuys, 1981a). Component C400 is tentatively shown as involved in a cycle around the photosystem (Babcock and Sauer, 1975; Bowes *et al.*, 1979a). $Q_I \equiv Q_A$; $Q_{II} \equiv Q_B$.

1977) are on the low potential side of the components Z_1 and Z_2 , or that the rates of proton release are determined by secondary reactions. The first of these possibilities is in agreement with the observation that over the physiological range (pH 6–8) there was no marked effect on the amplitude or kinetics of events leading to the reduction of $P680^+$ in the time range between 7 and 100 μsec , as revealed by the kinetics of delayed fluorescence decay over this time range (Bowes *et al.*, 1979b).

In view of the present uncertainty about the pattern of proton release and our ignorance of the chemical nature of the reactants in the water-oxidizing reaction, it seems premature to speculate further on its mechanism.

C. Chloroplast Photosystem II—Acceptor Side

The main controversy in this area has been over the question of the stoichiometry of H^+ uptake—electrons transferred between the systems, with results between 1 and 2 being reported. It has become clear that the stoichiometry is variable, and depends on the functioning of an additional proton-pumping loop in this section of the chain discussed earlier in Section VII.E. The extra loop operates only when intermediate com-

ponents are poised at the right redox potential and when the value of the proton gradient is relatively small (Bouges-Bocquet, 1981b). However, much of the early work on stoichiometry was performed under conditions that turn off the extra loop. These conditions were the use of continuous light of relatively high intensity or flash excitation with a relatively short interval between flashes (with or without ferricyanide as an electron acceptor). Crofts (1970) reported a stoichiometry of 3 H^+/e for electron transfer from water to NADP (with ferredoxin), but assumed that the value was an overestimate because of a contribution from cyclic electron flow. Rathenow and Rumberg (1980) reported briefly that at relatively low light intensities, the stoichiometry was greater than 1 H^+/e for the intersystem span, and more recently Velthuys (1978, 1980a, b) and Olsen and Cox (1979) have shown similar excess stoichiometries.

Two major unresolved anomalies are (1) the discrepancy between the observed rate of proton uptake and the known rates of electron transfer to H-carriers of the intermediate chain; and (2) the failure to see any binary pattern in proton uptake as a function of flash number from the dark adapted state, as would be expected from the now well-characterized operation of a two-electron gate on the secondary acceptor Q_B . Little new information is available to explain these anomalies.

D. Characteristics of Rapid H^+ Uptake in Chromatophores

The systems most studied have been chromatophores from *Rp. sphaeroides* and *Rp. capsulata*. Where these studies have been similar, the results have been similar, and we will not attempt to distinguish between them here. Early work was reviewed by Wraight *et al.* (1978), and we will summarize the results here and discuss briefly more recent data.

1. RAPID PROTON UPTAKE IN THE PRESENCE OF ANTIMYCIN

Flash excitation of chromatophores in the presence of antimycin leads to uptake of 1 H^+ per reaction center, called H_1^+ . The H^+ disappears with $t_{1/2} \sim 120 \mu\text{sec}$, and shows a pK at 8.5; these characteristics are not modified by valinomycin (Cogdell *et al.*, 1972). The dependence on redox potential is complex. At high E_h , H^+ -uptake titrates in on reduction of P870. At low E_h , it titrates out on reduction of a H carrier with a value for E_h considerably more positive than that of Q_A (Cogdell *et al.*, 1972). Petty *et al.* (1979) made a detailed study of the dependence on ambient redox potential and concluded that the component has an E_m of 90 mV, varying by -60 mV/pH and showing an n value of 1. These values are similar to those for the couple Q_B/Q_BH^+ found by Rutherford and Evans

(1980), and the uptake of H_1^+ is not seen in chromatophores depleted of Q_B (Takamiya and Dutton, 1979). These observations seem to suggest that H_1^+ is taken up on reduction of Q_B to Q_BH . However, as noted earlier, the reduced species seen on reduction of Q_B is $Q_B^{\dot{-}}$ (de Grooth *et al.*, 1978; Bowyer *et al.*, 1979). Furthermore, the behavior of H_1^+ seems to be modified by the redox state of Cyt b_{561} (Petty *et al.*, 1979); it seems possible that the uptake of H_1^+ is not a simple redox linked protolytic reaction, but may reflect the involvement of a proteinaceous H^+ -binding site, the pK of which is determined by the redox state of Q_B (and possibly by Cyt b_{561}), such as that identified by Wraight (1979) in reaction centers. The interpretation of the properties of H_1^+ binding is further complicated by the possible heterogeneity of centers with respect to the redox state of Q_B . At low redox potentials, H^+ uptake was only partly sensitive to orthophenanthroline (Cogdell *et al.*, 1972) suggesting that in a fraction of centers (Vermeglio *et al.*, 1980b; Wraight and Stein, 1980), the uptake of H^+ was associated with the reduction of $Q_B^{\dot{-}}$ to Q_BH_2 . In any case, it is clear that in chromatophores, the binding of H_1^+ is not an electrogenic process, since no phase of the carotenoid change with similar kinetics or redox properties is seen.

The release of the proton bound in the presence of antimycin is seen only on addition of protonophore and at values of pH above the pK of 7.5 on Cyt b_{561} , when the Cyt no longer acts as an H carrier. In the absence of antimycin, protonophore-dependent release of a proton is seen at lower values of pH when Cyt b_{561} goes oxidized (Petty and Dutton, 1976). In summary, it appears that the uptake of H_1^+ reflects a protolytic reaction directly or indirectly associated with reduction of Q_B (or $Q_B^{\dot{-}}$), which is part of a neutral H-carrying process involving both Q_B and Cyt b_{561} , leading to release of an H^+ to a phase (presumably the internal aqueous phase) accessible to protonophores, but not to externally added indicators (cf. Fig. 7).

2. PROTON UPTAKE IN THE ABSENCE OF ANTIMYCIN

In the absence of antimycin, flash excitation leads to the uptake of H^+/RC . This maximal stoichiometry is seen in the presence of valinomycin at E_h values around 90 mV (at pH 7) where Q_z (or the quinone pool) is reduced before the flash, and rapid electron transfer through the ubiquinol:Cyt $_1c$ oxidoreductase complex is seen (Cogdell *et al.*, 1972; Evans and Crofts, 1974b; Crofts *et al.*, 1976). Under these circumstances, the extra H^+ taken up shows a $t_{1/2}$ of ~ 1.5 msec—essentially the same as the rate of antimycin sensitive electron transfer from Cyt b_{561} , and to RFeS and the c -Cyt, and as the electrogenic process indicated by the slow phase of the carotenoid change. The UHDBT-sensitive reduction of the Cyt c_1 and c_2 is not electrogenic (Bowyer *et al.*, 1980), and the antimycin

sensitive reduction appears to involve oxidation of an H carrier (QH_2) and would be expected to be neutral. The most reasonable assumption is therefore that the H^+ uptake is associated with the reaction in which QH_2 is regenerated (the reaction at the Q_C site of Fig. 7), and that this reaction is also electrogenic.

The extra H^+ taken up in the absence of antimycin has been called H_{II}^+ . The kinetic and thermodynamic properties of the reactions associated with H_{II}^+ uptake have been studied by simple subtraction of the traces for H^+ uptake obtained in the presence of antimycin from those obtained in the absence of antimycin (Petty *et al.*, 1979). It should be noted that this procedure presupposes that antimycin does not modify the kinetics or redox properties of H_{II}^+ binding.

3. PROPERTIES OF H_{II}^+ UPTAKE

The extent of H_{II}^+ uptake is modified by valinomycin. In earlier studies Cogdell *et al.* (1972) found that the uptake of an extra H^+ was largely dependent on valinomycin. Petty *et al.* (1979) found that the dependence was variable and that up to 0.8 $\text{H}_{\text{II}}^+/\text{RC}$ could be seen in the absence of valinomycin. The dependence on valinomycin was much greater at high values of E_h (>300 mV) than at lower values (<250 mV). This effect was attributed to a change in pK of the group associated with binding of H_{II}^+ . In the presence of valinomycin, an extra H^+ uptake was seen over the E_h range from 450 mV (on reduction of P870^+) down to ~ 10 mV (at pH 7) (Cogdell *et al.*, 1972; Evans and Crofts, 1974b). Petty *et al.* (1979) showed that H_{II}^+ binding showed kinetics which varied dramatically with ambient redox potential. At $E_\text{h} > 150$ mV, H_{II}^+ binding had a $t_{1/2} \sim 200$ μsec ; at $E_\text{h} < 150$ mV, $t_{1/2}$ slowed to ~ 1.5 msec. This change in kinetics was associated with chemical reduction of Q_Z in the dark, but may have reflected partial reduction of the quinone pool.

Although as discussed earlier, the kinetics observed when Q_Z (or the pool) is reduced before the flash are consistent with a dependence of H_{II}^+ binding on electron transfer processes occurring in the ubiquinol-Cyt *c* oxidoreductase complex, the rapid kinetics seen at higher values of E_h are anomalous and are not readily explained by current models.

This chapter has provided a detailed survey of the electron and proton translocation in both green plants and photosynthetic bacteria. For details on what is known about the pathways involved in O_2 evolution, the reader is encouraged to read Wydrzynski (Chapter 10, this volume) and about the pathways involved in phosphorylation, the reader should consult Ort and Melandri (Chapter 12) and Junge and Jackson (Chapter 13, this volume).

Acknowledgments

We are grateful to the many colleagues who communicated to us data or manuscripts of interest to this article prior to publication. We would like to thank Ruth Rafferty for much help in the preparation of the manuscript, and Darlene Bouck, Renna Demetrulias, Kathy White, and Agnès Rutherford for the final typing.

REFERENCES

- Adman, E. T. (1979). *Biochim. Biophys. Acta* **549**, 107–144.
- Almasy, R. J., and Dickerson, R. E. (1978). *Proc. Natl. Acad. Sci. U.S.A.* **75**, 2674–2678.
- Anderson, J. M. (1981). *FEBS Lett.* **124**, 1–10.
- Arntzen, C. J., Ditto, C. L., and Brewer, P. E. (1979). *Proc. Natl. Acad. Sci. U.S.A.* **76**, 278–287.
- Ausländer, W., and Junge, W. (1974). *Biochim. Biophys. Acta* **545**, 316–324.
- Avron, M. (1975). In "Bioenergetics of Photosynthesis" (Govindjee, ed.), pp. 373–386. Academic Press, New York.
- Babcock, G. T., and Sauer, K. (1975). *Biochim. Biophys. Acta* **376**, 329–344.
- Babcock, G. T., Blankenship, R. E., and Sauer, K. (1976). *FEBS Lett.* **61**, 286–289.
- Baccarini-Melandri, A., Gabellini, N., Melandri, B. A., Hurt, E., and Hauska, G. (1980). *J. Bioenerg. Biomembr.* **12**, 95–110.
- Baccarini-Melandri, A., Gabellini, N., Melandri, B. A., Jones, K. R., Rutherford, A. W., Crofts, A. R., and Hurt, E. (1982). *Arch. Biochem. Biophys.*, **216**, 566–580.
- Baker, N. R., and Horton, P. (1980). *Biochim. Biophys. Acta* **592**, 559–564.
- Barber, J. (1981). *Proc. Int. Congr. Photosynth.*, 5th 1, 385–396.
- Barouch, Y., and Clayton, R. K. (1977). *Biochim. Biophys. Acta* **462**, 785–788.
- Baxendale, J. H., and Hardy, H. R. (1953a). *Trans. Faraday Soc.* **49**, 1140–1144.
- Baxendale, J. H., and Hardy, H. R. (1953b). *Trans. Faraday Soc.* **49**, 1433–1437.
- Beinert, H. (1977). In "Iron-Sulfur Proteins" (W. Lovenberg, ed.), Vol. 3, pp. 61–100. Academic Press, New York.
- Bendall, D. S. (1977). *Int. Rev. Biochem.* **13**, 41–78.
- Bendall, D. S., and Wood, P. M. (1978). *Proc. Int. Congr. Photosynth.*, 4th, 1977 pp. 771–775.
- Bengis, C., and Nelson, N. (1977). *J. Biol. Chem.* **252**, 4564–4569.
- Ben-Hayyim, G. (1974). *FEBS Lett.* **41**, 191–196.
- Bennett, J., Steinback, K. E., and Arntzen, C. J. (1980). *Proc. Natl. Acad. Sci. U.S.A.* **77**, 5253–5257.
- Bensasson, R., and Land, E. J. (1973). *Biochim. Biophys. Acta* **325**, 175–181.
- Blankenship, R. E., and Parson, W. W. (1979a). *Biochim. Biophys. Acta* **545**, 429–444.
- Blankenship, R. E., and Parson, W. W. (1979b). In "Photosynthesis in Relation to Model Systems" (J. Barber, ed.), pp. 71–114. Elsevier/North-Holland, Amsterdam.
- Boardman, N. K., Bjorkman, O., Anderson, J. M., Goodchild, D. J., and Thorne, S. W. (1975). *Proc. Int. Congr. Photosynth.*, 3rd, 1974 pp. 1809–1827.
- Böhme, H. (1976). *Z. Naturforsch.*, **31C**, 68–77.
- Böhme, H. (1978). *Eur. J. Biochem.* **84**, 87–93.
- Böhme, H. (1979). *Eur. J. Biochem.* **93**, 287–293.
- Böhme, H. (1980). *FEBS Lett.* **112**, 13–16.
- Böhme, H., and Cramer, W. A. (1972). *Biochim. Biophys. Acta* **283**, 302–315.
- Böhme, H., and Cramer, W. A. (1973). *Biochim. Biophys. Acta* **325**, 275–283.

- Böhme, H., Reimer, S., and Trebst, A. (1969). *Z. Naturforsch. B: Anorg. Chem; Org. Chem., Biochem., Biophys., Biol.* **26 B**, 341–352.
- Böhme, H., Brutsch, S., Weithmann, G., and Böger, P. (1980a). *Biochim. Biophys. Acta* **590**, 248–260.
- Böhme, H., Pelzer, B., and Böger, P. (1980b). *Biochim. Biophys. Acta*, **592**, 528–535.
- Bohner, H., and Böger, P. (1978). *FEBS Lett.* **85**, 337–339.
- Bouges-Bocquet, B. (1973). *Biochim. Biophys. Acta* **314**, 250–256.
- Bouges-Bocquet, B. (1975). *Proc. Int. Conf. Photosynth., 3rd, 1974 I*, 579–588.
- Bouges-Bocquet, B. (1977). *Biochim. Biophys. Acta* **462**, 371–379.
- Bouges-Bocquet, B. (1980a). *FEBS Lett.* **117**, 54–58.
- Bouges-Bocquet, B. (1980b). *Biochim. Biophys. Acta* **594**, 85–103.
- Bouges-Bocquet, B. (1981a). *Proc. Int. Conf. Photosynth., 5th, 1981 II*, 19–27.
- Bouges-Bocquet, B. (1981b). *Biochim. Biophys. Acta* **635**, 327–340.
- Bowes, J. M., and Crofts, A. R. (1978). *Z. Naturforsch., C: Biosci.* **33C**, 271–275.
- Bowes, J. M., and Crofts, A. R. (1980). *Biochim. Biophys. Acta* **590**, 373–384.
- Bowes, J. M., and Crofts, A. R. (1981). *Arch. Biochem. Biophys.* **209**, 682–686.
- Bowes, J. M., Crofts, A. R., and Itoh, S. (1979a). *Biochim. Biophys. Acta* **547**, 320–335.
- Bowes, J. M., Crofts, A. R., and Itoh, S. (1979b). *Biochim. Biophys. Acta* **547**, 336–347.
- Bowes, J. M., Crofts, A. R., and Arntzen, C. J. (1980). *Arch. Biochem. Biophys.* **200**, 303–308.
- Bowes, J. M., Horton, P., and Bendall, D. S. (1981). *FEBS Lett.* **135**, 261–264.
- Bowyer, J. R., and Crofts, A. R. (1978). In "Frontiers of Biological Energetics" (P. L. Dutton, J. S. Leigh, and A. D. Scarpa, eds.), Vol. I, pp. 326–333. Academic Press, New York.
- Bowyer, J. R., and Crofts, A. R. (1980). *Arch. Biochem. Biophys.* **202**, 582–591.
- Bowyer, J. R., and Crofts, A. R. (1981). *Biochim. Biophys. Acta* **636**, 218–233.
- Bowyer, J. R., Baccarini-Melandri, A., Melandri, B. A., and Crofts, A. R. (1978). *Z. Naturforsch., C: Biosci.* **33C**, 704–711.
- Bowyer, J. R., Tierney, G. V., and Crofts, A. R. (1979). *FEBS Lett.* **101**, 201–206.
- Bowyer, J. R., Dutton, P. L., Prince, R. C., and Crofts, A. R. (1980). *Biochim. Biophys. Acta* **592**, 445–460.
- Bowyer, J., Meinhardt, S. W., Tierney, G. V., and Crofts, A. R. (1981a). *Biochim. Biophys. Acta* **635**, 167–186.
- Bowyer, J., Edwards, C. A., and Trumpower, B. L. (1981b). *FEBS Lett.* **126**, 93–97.
- Brand, J., Baszinski, T., Crane, F. L., and Krogmann, D. W. (1972). *J. Biol. Chem.* **247**, 2814–2819.
- Brautigan, D. L., Ferguson-Miller, S., and Margoliash, E. (1978a). *J. Biol. Chem.* **253**, 130–139.
- Brautigan, D. L., Ferguson-Miller, S., and Margoliash, E. (1978b). *J. Biol. Chem.* **253**, 140–148.
- Briantais, J.-M., Vernotte, C., Picaud, M., and Krause, G. H. (1979). *Biochim. Biophys. Acta* **548**, 128–138.
- Bridge, N. K., and Porter, C. (1958). *Proc. R. Soc. London, Ser. A* **244**, 276–288.
- Brogliè, R. M., Hunter, C. N., Delepelair, P., Niederman, R. A., Chua, N.-H., and Clayton, R. K. (1980). *Proc. Natl. Acad. Sci. U.S.A.* **77**, 87–91.
- Butler, W. F., Johnston, D. C., Shore, H. B., Fredkin, D. R., Okamura, M. Y., and Feher, G. (1980). *Biophys. J.* **32**, 967–992.
- Butler, W. L. (1962). *Biochim. Biophys. Acta* **64**, 309–317.
- Butler, W. L. (1972). *Proc. Natl. Acad. Sci. U.S.A.* **69**, 3420–3422.
- Butler, W. L. (1978). *FEBS Lett.* **95**, 19–25.
- Cammack, R., Dickson, D. P. E., and Johnson, L. E. (1977). In "Iron-Sulfur Proteins" (W. Lovenberg, ed.), Vol. 3, pp. 283–330. Academic Press, New York.

- Case, G. D., and Parson, W. W. (1971). *Biochim. Biophys. Acta* **253**, 187–202.
- Case, G. D., and Parson, W. W. (1973). *Biochim. Biophys. Acta* **325**, 441–453.
- Chance, B., DeVault, D. C., Frauenfelder, H., Marcus, R. A., Schrieffer, J. R., and Sutin, N., eds. (1979). "Tunneling in Biological Systems." Academic Press, New York.
- Chance, B., Crofts, A. R., Nishimura, M., and Price, B. (1970). *Eur. J. Biochem.* **13**, 364–374.
- Clark, W. M. (1960). "Oxidation-Reduction Potentials of Organic Systems." Chapter 7. Williams & Wilkins, Baltimore, Maryland.
- Cogdell, R. J., and Thornber, J. P. (1980). *FEBS Lett.* **122**, 1–8.
- Cogdell, R. J., Jackson, J. B., and Crofts, A. R. (1972). *J. Bioenerg.* **4**, 211–227.
- Colman, P. M., Freeman, H. C., Guss, J. M., Murata, M., Norris, V. A., Ramshaw, J. A., and Venkatappa, M. P. (1978). *Nature (London)* **272**, 319–324.
- Conjeaud, H., Mathis, P., and Paillotin, G. (1979). *Biochim. Biophys. Acta* **546**, 280–291.
- Cox, R. P., and Bendall, D. S. (1974). *Biochim. Biophys. Acta* **347**, 49–59.
- Cramer, W. A. (1969). *Biochim. Biophys. Acta* **189**, 54–59.
- Cramer, W. A., and Butler, W. L. (1967). *Biochim. Biophys. Acta* **143**, 332–339.
- Cramer, W. A., and Butler, W. L. (1969). *Biochim. Biophys. Acta* **172**, 503–510.
- Cramer, W. A., and Whitmarsh, J. (1977). *Annu. Rev. Plant Physiol.* **28**, 133–172.
- Cramer, W. A., and Whitmarsh, J. (1979). In "Tunneling in Biological Systems" (B. Chance, D. DeVault, H. Frauenfelder, R. A. Marcus, J. R. Schrieffer, and N. Sutin, eds.), p. 3. Academic Press, New York.
- Cramer, W. A., Whitmarsh, J., and Horton, P. (1979). In "The Porphyrins" (D. Dolphin, ed.), **7**, pp. 71–106, Academic Press, New York.
- Cramer, W. A., Whitmarsh, J., and Low, P. J. (1981a). *Biochemistry* **20**, 157–162.
- Cramer, W. A., Whitmarsh, J., and Widger, W. (1981b). *Proc. Int. Congr. Photosynth.*, **5th** II, 509–521.
- Crane, F. L. (1965). In "The Biochemistry of Quinones" (R. A. Morton, ed.), pp. 183–206. Academic Press, New York.
- Crofts, A. R. (1974). In "Perspectives in Membrane Biology" (S. Estrada-O and C. Gitler, eds.), pp. 373–412. Academic Press, New York.
- Crofts, A. R., and Jackson, J. B. (1970). In "Electron Transport and Energy Conversation" (J. M. Tager, S. Papa, E. Quagliariello, and E. C. Slater, eds.), pp. 383–408. Adriatica Editrice, Bari.
- Crofts, A. R., and Meinhardt, S. W. (1982). *Biochem. Soc. Trans.* (in press).
- Crofts, A. R., and Wood, P. M. (1978). *Curr. Top. Bioenerg.* **7**, 175–244.
- Crofts, A. R., Crowther, D., and Tierney, G. V. (1975a). In "Electron Transfer Chains and Oxidative Phosphorylation" (E. Quagliariello, S. Papa, F. Palmieri, E. C. Slater, and N. Siliprandi, eds.), pp. 233–241. Elsevier/North-Holland, Amsterdam.
- Crofts, A. R., Prince, R. C., Holmes, N. G., and Crowther, D. (1975b). *Proc. Int. Congr. Photosynth.*, **3rd**, 1974 pp. 1131–1146.
- Crofts, A. R., Crowther, D., Celis, H., Celis, S., and Tierney, G. V. (1977a). *Biochem. Soc. Trans.* **5**, 491–495.
- Crofts, A. R., Crowther, D., Bowyer, J., and Tierney, G. V. (1977b). In "Structure and Function of Energy-Transducing Membranes" (K. Van Dan and B. F. van Gelder, eds.), pp. 133–155. Elsevier/North-Holland, Amsterdam.
- Crofts, A. R., Meinhardt, S. W., and Bowyer, J. R. (1982a). In "Function of Quinones in Energy-Conserving Systems" (B. Trumpower, ed.), pp. 447–498, Academic Press, New York.
- Crofts, A. R., Meinhardt, S. W., Shozzi, M., and Jones, K. R. (1982b). *Abst. 2nd Europ. Bioenergetics Conf.*, Lyon, July 1982.
- Crowther, D., and Hind, G. (1980). *Arch. Biochem. Biophys.* **204**, 568–577.

- Crowther, D., Mills, T. D., and Hind, G. (1979). *FEBS Lett.* **98**, 386–390.
- Cusanovich, M. A., and Mizrahi, I. A. (1979). In "Tunneling in Biological Systems" (B. Chance, D. C. DeVault, H. Franenfelder, R. A. Marcus, J. R. Schrieffer, and N. Sutin, eds.), pp. 355–362. Academic Press, New York.
- Debrunner, P. G., Schulz, C. E., Feher, G., and Okamura, M. Y. (1975). *Biophys. Soc. Abstr.* **15**, 22a.
- Debus, R. J., Okamura, M. Y., and Feher, G. (1981). *Biophys. Soc. Abstr.* **33**, 19a.
- de Grooth, B. G., and Amesz, J. (1977a). *Biochim. Biophys. Acta* **462**, 237–246.
- de Grooth, B. G., and Amesz, J. (1977b). *Biochim. Biophys. Acta* **462**, 247–258.
- de Grooth, B. G., van Grondelle, R., Romijn, J. C., and Pulles, M. P. J. (1978). *Biochim. Biophys. Acta* **503**, 480–490.
- de Grooth, B. G., van Gorkom, H. J., and Meiburg, R. F. (1980a). *Biochim. Biophys. Acta* **589**, 299–314.
- de Grooth, B. G., van Gorkom, H. J., and Meiburg, R. F. (1980b). *FEBS Lett.* **113**, 21–24.
- den Haan, G. A., Duysens, L. N. H., and Egberts, D. J. N. (1974). *Biochim. Biophys. Acta* **368**, 409–421.
- de Kouchkovsky, Y., and de Kouchkovsky, F. (1974). *Biochim. Biophys. Acta* **368**, 113–124.
- DeVault, D. C. (1980). *Q. Rev. Biophys.* **13**, 387–564.
- DeVault, D. C., and Chance, B. (1966). *Biophys. J.* **6**, 825–847.
- de Vries, S., Berden, J. A., and Slater, E. C. (1980). *FEBS Lett.* **122**, 143–148.
- Dickersou, R. E., and Timkovich, R. (1975). In "The Enzymes" (P. Boyer, ed.), 3rd ed., Vol. 11, pp. 397–547. Academic Press, New York.
- Diner, B. A. (1977). *Biochim. Biophys. Acta* **460**, 247–258.
- Dutton, P. L., and Prince, R. C. (1978a). *FEBS Lett.* **91**, 15–20.
- Dutton, P. L., and Prince, R. C. (1978b). In "The Photosynthetic Bacteria" (R. K. Clayton and W. R. Siström, eds.), pp. 525–570. Plenum, New York.
- Duysens, L. N. M. (1972). *Biophys. J.* **12**, 858–863.
- Duysens, L. N. M., and Sweers, H. E. (1963). In "Microalgae and Photosynthetic Bacteria" (Jpn. Soc. Plant Physiol., ed.), pp. 353–372. Univ. of Tokyo Press, Tokyo.
- Erixon, K., and Butler, W. L. (1971). *Biochim. Biophys. Acta* **234**, 381–389.
- Evans, E. H., and Crofts, A. R. (1974a). *Biochim. Biophys. Acta* **333**, 44–51.
- Evans, E. H., and Crofts, A. R. (1974b). *Biochim. Biophys. Acta* **357**, 89–102.
- Evans, M. C. W., Lord, A. V., and Reeves, S. G. (1974). *Biochem. J.* **138**, 177–183.
- Feher, G., and Okamura, M. Y. (1978). In "The Photosynthetic Bacteria" (R. K. Clayton and W. Siström, eds.), pp. 349–386. Plenum, New York.
- Ferguson-Miller, S., Brautigan, D. L., and Margoliash, E. (1978). *J. Biol. Chem.* **253**, 149–159.
- Forbush, B., and Kok, B. (1968). *Biochim. Biophys. Acta* **162**, 243–253.
- Fork, D., Murata, N., and Sato, N. (1979). *Plant Physiol.* **63**, 524–530.
- Förster, V., Hong, Y.-Q., and Junge, W. (1981). *Biochim. Biophys. Acta*, **638**, 141–152.
- Fowler, C. F. (1976). *Abstr. Int. Conf. Primary Electron Transport Energy Transduction Photosynth. Bacteria, 1976* Abstract WB9.
- Fowler, C. F. (1977). *Biochim. Biophys. Acta* **459**, 351–363.
- Fowler, C. F., and Kok, B. (1974). *Biochim. Biophys. Acta* **357**, 299–307.
- Furtado, D., Williams, W. P., Brain, A. P. R., and Quinn, P. J. (1979). *Biochim. Biophys. Acta* **555**, 352–357.
- Futami, A., and Hauska, G. (1979). *Biochim. Biophys. Acta* **547**, 597–608.
- Futami, A., Hurt, E., and Hauska, G. (1979). *Biochim. Biophys. Acta* **547**, 583–596.
- Gabellini, N., Bowyer, J. R., Hurt, E., Melandri, B. A., and Hauska, G. (1982). *J. Bioenerg. Biomemb.*, in press.

- Garewal, H. S., and Wasserman, A. R. (1974). *Biochemistry* **13**, 4072-4079.
- Garland, P. B., Clegg, R. A., Boxer, D., Downie, J. A., and Haddock, B. A. (1975). In "Electron Transfer Chains and Oxidative Phosphorylation." (E. Quagliariello, S. Papa, F. Palmieri, E. C. Slater and N. Siliprandi, eds.), pp. 351-358. North-Holland Publ. Co., Amsterdam.
- Golbeck, J. H., and Kok, B. (1979). *Biochim. Biophys. Acta* **547**, 347-360.
- Govindjee, ed. (1982). "Photosynthesis: Development, Carbon Metabolism, and Plant Productivity," Vol. II. Academic Press, New York.
- Govindjee, and Govindjee, R. (1965). *Photochem. Photobiol.* **4**, 675-683.
- Govindjee, and Govindjee, R. (1975). In "Bioenergetics of Photosynthesis" (Govindjee, ed.), pp. 1-50. Academic Press, New York.
- Govindjee, and Jursinic, P. (1979). *Photochem. Photobiol. Rev.* **4**, 125-205.
- Govindjee, and van Rensen, J. J. S. (1978). *Biochim. Biophys. Acta* **505**, 183-213.
- Govindjee, Ichimura, S., Cederstrand, C., and Rabinowitch, E. (1960). *Arch. Biochem. Biophys.* **89**, 322-323.
- Govindjee, Pulles, M. P. J., Govindjee, R., Van Gorkom, H. J., and Duysens, L. N. M. (1976). *Biochim. Biophys. Acta* **449**, 536-540.
- Gray, J. (1978). *Eur. J. Biochem.* **82**, 133-141.
- Haehnel, W. (1973). *Biochim. Biophys. Acta* **305**, 618-631.
- Haehnel, W. (1977). *Biochim. Biophys. Acta* **459**, 418-441.
- Haehnel, W., Pröpper, A., and Krause, H. (1980). *Biochim. Biophys. Acta* **593**, 384-399.
- Hauska, G., and Hurt, E. (1981). In "Function of Quinones in Energy-Conserving Systems" (B. Trumpower, ed.). Academic Press, New York.
- Hauska, G., and Trebst, A. (1977). *Curr. Top. Bioenerg.* **6**, 152-220.
- Hauska, G. A., McCarty, R. E., Berzborn, R. J., and Racker, E. (1971). *J. Biol. Chem.* **246**, 3524-3531.
- Hauska, G., Orlich, G., Samoray, D., Hurt, E., and Sane, P. V. (1981). *Proc. Int. Congr. Photosyn.*, 5th, 1981 II, 903-914.
- Heber, U., Boardman, N. K., and Anderson, J. M. (1976). *Biochim. Biophys. Acta* **423**, 275-292.
- Heber, U., Kirk, M. R., and Boardman, N. K. (1979). *Biochim. Biophys. Acta* **546**, 292-306.
- Hind, G., and Nakatani, H. (1970). *Biochim. Biophys. Acta* **216**, 223-225.
- Hind, G., Crowther, D., Shahak, Y., and Slovacek, R. E. (1981). *Proc. Int. Conf. Photosynth.*, 5th, 1981 II, 87-97.
- Hirano, M., Satoh, K., and Katoh, S. (1981). *Biochim. Biophys. Acta* **635**, 476-487.
- Ho, K. K., and Krogmann, D. W. (1980). *J. Biol. Chem.* **255**, 3855-3861.
- Holmes, N. G., and Crofts, A. R. (1977). *Biochim. Biophys. Acta* **459**, 492-505.
- Holmes, N. G., Hunter, C. N., Niederman, R. A., and Crofts, A. R. (1980). *FEBS Lett.* **115**, 43-48.
- Hope, A. B., and Morland, A. (1979). *Aust. J. Plant Physiol.* **6**, 1-6.
- Horton, P., and Cramer, W. A. (1974). *Biochim. Biophys. Acta* **368**, 348-360.
- Horton, P., and Croze, E. (1977). *Biochim. Biophys. Acta* **462**, 86-101.
- Horton, P., and Croze, E. (1979). *Biochim. Biophys. Acta* **545**, 188-201.
- Horton, P., Whitmarsh, J., and Cramer, W. A. (1976). *Arch. Biochem. Biophys.* **176**, 519-524.
- Horvath, G., Niemi, H. A., Droppa, M., and Faludi-Daniel, A. (1979). *Plant Physiol.* **63**, 778-782.
- Hurt, E., Hauska, G., and Malkin, R. (1981). *FEBS Lett.* **134**, 1-5.
- Itoh, S. (1978a), *Plant Cell Physiol.* **19**, 149-166.
- Itoh, S. (1978b). *Biochim. Biophys. Acta* **504**, 324-340.

- Itoh, S. (1979). *Biochim. Biophys. Acta* **548**, 579–595.
- Itoh, S. (1980). *Biochim. Biophys. Acta* **591**, 346–355.
- Jackson, J. B., and Crofts, A. R. (1969). *FEBS Lett.* **4**, 185–189.
- Jackson, J. B., and Crofts, A. R. (1971). *Eur. J. Biochem.* **18**, 120–130.
- Jackson, J. B., and Dutton, P. L. (1973). *Biochim. Biophys. Acta* **325**, 102–115.
- Jagendorf, A. T. (1975). In "Bioenergetics of Photosynthesis" (Govindjee, ed.), pp. 413–492. Academic Press, New York.
- Joliot, P., and Delosme, R. (1974). *Biochim. Biophys. Acta* **357**, 267–284.
- Joliot, A., and Joliot, P. (1964). *C. R. Hebd. Seances Acad. Sci.* **258**, 4622–4625.
- Joliot, P., and Joliot, A. (1973). *Biochim. Biophys. Acta* **305**, 302–316.
- Joliot, P., and Joliot, A. (1976). *C. R. Hebd. Seances Acad. Sci., Ser. D. Paris* **283**, 393–396.
- Joliot, P., and Joliot, A. (1979). *Biochim. Biophys. Acta* **546**, 93–105.
- Joliot, P., and Joliot, A. (1981). *Proc. Int. Congr. Photosynth., 5th* **III**, 885–899.
- Joliot, P., and Kok, B. (1975). In "Bioenergetics of Photosynthesis" (Govindjee, ed.), pp. 388–412. Academic Press, New York.
- Joliot, P., Bennoun, P., and Joliot, A. (1973). *Biochim. Biophys. Acta* **305**, 317–328.
- Joliot, P., Delosme, R., and Joliot, A. (1977). *Biochim. Biophys. Acta* **459**, 47–57.
- Junge, W. (1977). *Annu. Rev. Plant Physiol.* **28**, 503–536.
- Junge, W., Renger, G., and Ausländer, W. (1977). *FEBS Lett.* **79**, 155–159.
- Katoh, S., Shiratori, I., and Takamiya, A. (1962). *J. Biochem. (Tokyo)* **51**, 32–40.
- Kaufmann, K., Dutton, P. L., Netzel, T. L., Leigh, J. S., and Rentzepis, P. M. (1975). *Science* **188**, 1301–1304.
- Ke, B., Hawkrige, F. M., and Sahu, S. (1976). *Proc. Natl. Acad. Sci. U.S.A.* **73**, 2211–2215.
- Khanna, R., Pfister, A., Keresztes, A., van Rensen, J. J. S., and Govindjee (1981). *Biochim. Biophys. Acta* **634**, 105–116.
- Kimimura, M., and Katoh, S. (1972). *Biochim. Biophys. Acta* **283**, 270–292.
- Kingsley, P. B., and Feigenson, G. W. (1981). *Biochim. Biophys. Acta* **602**–618.
- Klimov, V. V., Klevanick, A. V., Shuvalov, V. A., and Krasnovskii, A. A. (1977). *FEBS Lett.* **82**, 183–186.
- Klimov, V. V., Allakhverdiev, S. I., Demeter, S., and Krasnovskii, A. A. (1980). *Dokl. Akad. Nauk SSSR* **249**, 227–230.
- Knaff, D. (1975). *FEBS Lett.* **60**, 331–335.
- Knaff, D. B., and Arnon, D. I. (1969a). *Proc. Natl. Acad. Sci. U.S.A.* **63**, 956–962.
- Knaff, D. B., and Arnon, D. I. (1969b). *Proc. Natl. Acad. Sci. U.S.A.* **63**, 963–969.
- Koike, H., Satoh, K., and Katoh, S. (1978). *Plant Cell Physiol.* **19**, 1371–1380.
- Krause, G. H., and Heber, U. (1976). *Top. Photosynth.*, **1**, 171–214.
- Labhart, J. (1967). *Adv. Chem. Phys.* **13**, 179–204.
- Lach, H.-J., and Böger, P. (1977a). *Z. Naturforsch. C: Biosci.* **32C**, 75–77.
- Lach, H.-J., and Böger, P. (1977b). *Z. Naturforsch. C: Biosci.* **32C**, 877–879.
- Lavorel, J. (1975). In "Bioenergetics of Photosynthesis" (Govindjee, ed.), pp. 223–317. Academic Press, New York.
- Liptay, W. (1969). *Angew. Chem., Int. Ed. Engl.* **8**, 177–188.
- Loach, P. A., and Hall, R. L. (1972). *Proc. Natl. Acad. Sci. U.S.A.* **69**, 786–790.
- Low, P. S., Whitmarsh, J. C., and Cramer, W. A. (1982) manuscript in preparation.
- Malkin, R. (1975). *Biochem. Biophys. Res. Commun* **63**, 1157–1160.
- Malkin, R. (1978). *FEBS Lett.* **87**, 329–333.
- Malkin, R. (1981a). In "Function of Quinones in Energy Converting Systems" (B. Trumppower, ed.), Academic Press, New York (in press).
- Malkin, R. (1981b). *Proc. Int. Congr. Photosynth., 5th*, **11**, 643–653.
- Malkin, R., and Barber, J. (1979). *Arch. Biochem. Biophys.* **193**, 169–178.
- Malkin, R., and Chain, R. K. (1980). *Biochim. Biophys. Acta* **591**, 381–390.

- Malviya, A. N., Nicholl, P., and Elliott, W. B. (1980). *Biochem. Biophys. Acta*, **589**, 137–149.
- Marcus, R. (1965). *J. Chem. Phys.* **43**, 679–701.
- Maroc, J., and Garnier, J. (1979). *Plant Cell Physiol.* **20**, 1029–1040.
- Marsho, T., and Kok, B. (1970). *Biochim. Biophys. Acta* **223**, 240–250.
- Mathis, P., and Haveman, J. (1976). *Biochim. Biophys. Acta* **461**, 167–181.
- Matsubara, H., Sasaki, R. M., and Chain, R. K. (1967). *Proc. Natl. Acad. Sci. U.S.A.* **57**, 439–445.
- Matsuura, K., Ishikawa, T., and Nishimura, M. (1980a). *Biochim. Biophys. Acta* **590**, 339–344.
- Matsuura, K., Masamoto, K., Itoh, S., and Nishimura, M. (1980b). *Biochim. Biophys. Acta* **592**, 121–129.
- Matsuzaki, E., and Kamimura, Y. (1972). *Plant Cell Physiol.* **13**, 415–425.
- Matsuzaki, E., Kamimura, Y., Yanasani, T., and Yanushija, F. (1975). *Plant Cell Physiol.* **16**, 237–246.
- Melis, A. (1978). *FEBS Lett.* **95**, 202–206.
- Melis, A., and Duysens, L. N. M. (1979). *Photochem. Photobiol.* **29**, 373–382.
- Melis, A., and Homann, P. (1975). *Photochem. Photobiol.* **21**, 431–437.
- Metz, T. G., Wong, J., and Bishop, N. I. (1980). *FEBS Lett.* **114**, 61–66.
- Mills, T. D., Crowther, D., Slovacek, R. E., Hind, G., and McCarthy, R. E. (1979). *Biochim. Biophys. Acta* **547**, 127–137.
- Mitchell, P. (1966). *Biol. Rev. Cambridge Philos. Soc.* **41**, 445–502.
- Mitchell, P. (1976). *J. Theor. Biol.* **62**, 327–367.
- Mitchell, P. (1982). In "Function of Quinones in Energy Conserving Systems" (B. L. Trumpower, ed.). Academic Press, New York.
- Moya, I., Govindjee, Vernotte, C., and Briantais, J.-M. (1977). *FEBS Lett.* **75**, 13–18.
- Murakami, S. et al. (1975). In "Bioenergetics of Photosynthesis" (Govindjee, ed.). Academic Press, New York.
- Murata, N., and Sugahara, K. (1969). *Biochim. Biophys. Acta* **189**, 182–192.
- Nelson, N., and Neumann, J. (1972). *J. Biol. Chem.* **247**, 1817–1824.
- Nelson, N., and Racker, E. (1972). *J. Biol. Chem.* **247**, 3848–3853.
- Oettmeier, W., Masson, K., and Johanningmeier, V. (1980). *FEBS Lett.* **118**, 267–270.
- Oettmeier, W., Masson, K., and Godde, O. (1981). *Z. Naturforsch.* **36C**, 272–275.
- Ohnishi, T., and Trumpower, B. (1980). *J. Biol. Chem.* **255**, 3278–3284.
- Okamura, M. Y., Isaacson, R. A., and Feher, G. (1975). *Proc. Natl. Acad. Sci. U.S.A.* **72**, 3491–3495.
- Okamura, M. Y., Fredkin, D. R., Isaacson, R. A., and Feher, G. (1979). In "Tunneling in Biological Systems" (B. Chance, D. C. DeVault, H. Frauenfelder, R. A. Marcus, J. R. Schrieffer, and N. Sutin, eds.), pp. 729–743. Academic Press, New York.
- Okayama, S. (1976). *Biochim. Biophys. Acta* **440**, 331–336.
- Okayama, S., and Butler, W. L. (1972). *Plant Physiol.* **49**, 769–774.
- O'Keefe, D., Prince, R. C., and Dutton, P. L. (1981). In "Function of Quinones in Energy Conserving Systems" (B. L. Trumpower, ed.), Academic Press, New York (in press).
- Olsen, L. F., and Barber, J. (1981). *FEBS Lett.* **123**, 90–94.
- Olsen, L. F., and Cox, R. P. (1979). *Eur. J. Biochem.* **95**, 427–432.
- Olson, J. M., and Smillie, R. M. (1963). *N.A.S.—N.R.C., Publ.* **1145**, 56–65.
- Ono, T., and Murata, N. (1979). *Biochim. Biophys. Acta* **545**, 69–76.
- Palmer, G. (1977). In "Iron-Sulfur Proteins" (W. Lovenberg, ed.), Vol. 3, pp. 285–325. Academic Press, New York.
- Papageorgiou, G. (1975). In "Bioenergetics of Photosynthesis" (Govindjee, ed.), pp. 319–371. Academic Press, New York.
- Patel, K. B., and Wilson, R. L. (1973). *J. Chem. Soc., Faraday Trans.* **69**, 814–825.

- Pettigrew, G. (1978). *FEBS Lett.* **86**, 14–16.
- Petty, K. M., and Dutton, P. L. (1976). *Arch. Biochem. Biophys.* **172**, 346–353.
- Petty, K. M., Jackson, J. B., and Dutton, P. L. (1979). *Biochim. Biophys. Acta* **546**, 17–42.
- Plesnicar, M., and Bendall, D. S. (1970). *Biochim. Biophys. Acta* **216**, 192–199.
- Plesnicar, M., and Bendall, D. S. (1973). *Eur. J. Biochem.* **34**, 483–488.
- Prince, R. G., and Dutton, P. L. (1976). *Arch. Biochem. Biophys.* **172**, 329–334.
- Prince, R. C., and Dutton, P. L. (1977). *Biochim. Biophys. Acta* **462**, 731–747.
- Prince, R. C., Lindsay, J. G., and Dutton, P. L. (1975). *FEBS Lett.* **51**, 108–111.
- Prince, R. C., Matsuura, K., Hurt, E., Hauska, G., and Dutton, P. L. (1982a). *J. Biol. Chem.*, **257**, 3379–3381.
- Prince, R. C., O'Keefe, D., and Dutton, P. L. (1982b). In "Electron Transport and Photophosphorylation" (Barber, J., ed.), pp. 197–248. Elsevier Biomed. Press, Amsterdam.
- Pulles, M. P. J., Van Gorkom, H. J., and Willemsen, J. G. (1976). *Biochim. Biophys. Acta* **449**, 536–540.
- Radmer, R., and Ollinger, O. (1980). *FEBS Lett.* **110**, 57–61.
- Rathenow, M., and Rumberg, B. (1980). *Ber. Bunsenges Phys. Chem.* **84**, 1059–1062.
- Reed, D. W., Zankel, K. L., and Clayton, R. K. (1969). *Proc. Natl. Acad. Sci. U.S.A.* **63**, 42–46.
- Regitz, G., and Ohad, I. (1976). *J. Biol. Chem.* **251**, 247–252.
- Reich, R., and Schmidt, S. (1972). *Ber. Bunsenges Phys. Chem.* **76**, 58–598.
- Renger, G. (1972). *Eur. J. Biochem.* **27**, 259–269.
- Renger, G. (1976). *Biochim. Biophys. Acta* **440**, 287–300.
- Renger, G., and Tieman, R. (1979). *Biochim. Biophys. Acta* **545**, 316–324.
- Rich, P. R. (1982). *FEBS Lett.*, (in press).
- Rich, P., and Bendall, D. S. (1979). *FEBS Lett.* **105**, 189–194.
- Rich, P., and Bendall, D. S. (1980a). *Biochim. Biophys. Acta* **591**, 506–518. } *check?*
- Rich, P., and Bendall, D. S. (1980b). *Biochim. Biophys. Acta* **592**, 153–161. }
- Rich, P. R., Heathcote, P., Evans, M. C. W., and Bendall, D. S. (1980). *FEBS Lett.* **116**, 51–56.
- Rieder, R., and Bosshard, H. R. (1978a). *J. Biol. Chem.* **253**, 6045–6053.
- Rieder, R., and Bosshard, H. R. (1978b). *FEBS Lett.* **92**, 223–226.
- Rieske, J. S. (1976). *Biochim. Biophys. Acta* **456**, 195–247.
- Rieske, J. S., MacLennan, D. H., and Coleman, R. (1964a). *Biochem. Biophys. Res. Commun.* **15**, 338–344.
- Rieske, J. S., Hansen, R. F., and Zaugg, W. S. (1964b). *J. Biol. Chem.* **239**, 3017–3022.
- Robertson, R. N., and Boardman, N. K. (1975). *FEBS Lett.* **60**, 1–6.
- Rockley, M. G., Windsor, M. W., Cogdell, R. J., and Parson, W. W. (1975). *Proc. Natl. Acad. Sci. U.S.A.* **72**, 2251–2255.
- Rumberg, B. (1966). In "Currents in Photosynthesis" (J. B. Thomas and J. C. Goedheer, eds.), pp. 375–382. Donker Publ., Rotterdam, The Netherlands.
- Rutherford, A. W., and Evans, M. C. W. (1979). *FEBS Lett.* **104**, 227–230.
- Rutherford, A. W., and Evans, M. C. W. (1980). *FEBS Lett.* **110**, 257–261.
- Rutherford, A. W., Mullet, J. E., and Crofts, A. R. (1981). *FEBS Lett.* **123**, 235–237.
- Salemme, F. R. (1976). *J. Mol. Biol.* **102**, 563–568.
- Salemme, F. R. (1977). *Annu. Rev. Biochem.* **46**, 299–330. ∪
- Saphon, S., and Crofts, A. R. (1977). *Z. Naturforsch., β: Anorg. Chem., Org. Chem.* **32B**, 617–626. ∪
- Sato, N., Murata, N., Miura, Y., and Veta, N. (1979). *Biochim. Biophys. Acta* **572**, 19–28.
- Satoh, K. (1981). *Proc. Int. Congr. Photosynth., 5th* III, 607–616.
- Sauer, K., and Brewington, G. T. (1978). *Proc. Int. Congr. Photosynth., 4th*, 1977 pp. 409–421.

- Schapendonk, A. H. C. M. (1980). Ph.D. Thesis, University of Wageningen.
- Schwartz, M. (1968). *Nature (London)* **219**, 915-919.
- Scolnick, P. A., Zannoni, D., and Marrs, B. L. (1980). *Biochim. Biophys. Acta* **593**, 230-240.
- Sheriff, S., Teller, D. C., and Herriott, S. R. (1980). *Arch. Biochem. Biophys.* **205**, 499-502.
- Shuvalov, V. A., Klimov, V. V., Dolan, E., Parson, W. W., and Ke, B. (1980). *FEBS Lett.* **118**, 279-282.
- Siedow, J. N., Vickery, L. E., and Palmer, G. (1980). *Arch. Biochem. Biophys.* **203**, 101-107.
- Siggel, U., Renger, G., Stiehl, H. H., and Rumberg, B. (1972). *Biochim. Biophys. Acta* **256**, 328-335.
- Silvius, J. R., Read, B. D., and McElhaney, R. N. (1978). *Science* **199**, 902-904.
- Slovacek, R. E., Crowther, D., and Hind, G. (1979). *Biochim. Biophys. Acta* **547**, 138-148.
- Slovacek, R. E., Crowther, D., and Hind, G. (1980). *Biochim. Biophys. Acta* **592**, 495-505.
- Smith, D. D., Selman, B. R., Voegeli, K. K., Johnson, G., and Dilley, R. A. (1976). *Biochim. Biophys. Acta* **459**, 468-482.
- Speck, S. H., Ferguson-Miller, S., Osheroff, N., and Margoliash, E. (1979). *Proc. Natl. Acad. Sci. U.S.A.* **76**, 155-159.
- Steinback, K., Burke, J. J., and Arntzen, C. (1979). *Arch. Biochem. Biophys.* **195**, 546-557.
- Steinback, K. E., Pfister, K., and Arntzen, C. J. (1981). *Z. Naturforsch., C: Biosci.* **36C**, 98-108.
- Suehl, H. H., and Witt, H. T. (1969). *Z. Naturforsch., B: Anorg. Chem., Org. Chem., Biochem., Biophys., Biol.* **24B**, 1588-1598.
- Stuart, A. L., and Wasserman, A. R. (1975). *Biochim. Biophys. Acta* **376**, 561-572.
- Symons, M., Nuyten, A., and Sybesma, C. (1979). *FEBS Lett.* **107**, 10-14.
- Tagawa, K., and Arnon, D. I. (1962). *Nature (London)* **195**, 537-543.
- Takamiya, K., and Dutton, A. L. (1979). *Biochim. Biophys. Acta* **546**, 1-16.
- Takamiya, K., Prince, R. C., and Dutton, P. L. (1979). *J. Biol. Chem.* **254**, 11307-11311.
- Tanaka, K., Takahashi, M., and Asada, K. (1978). *J. Biol. Chem.* **253**, 7397-7403.
- Thielen, A. P. G. M., and van Gorkom, H. J. (1981). *FEBS Lett.* **129**, 205-209.
- Toppen, D. L. (1976). *J. Am. Chem. Soc.* **98**, 4023-4024.
- Trebst, A. (1974). *Annu. Rev. Plant Physiol.* **25**, 423-458.
- Trebst, A. (1979). *Z. Naturforsch. C: Biosci.* **34C**, 986-991.
- Trumpower, B. L., and Edwards, C. A. (1979). *J. Biol. Chem.* **254**, 8697-8706.
- Trumpower, B. L., and Katki, A. G. (1979). In "Membrane Proteins in Energy Transduction" (R. A. Capaldi, ed.), pp. 89-200. Academic Press, New York.
- Ulrich, E., Girvin, M., Cramer, W. A., Markley, J. (1982) manuscript in preparation.
- Urban, P. F., and Klingenberg, M. (1969). *Eur. J. Biochem.* **9**, 519-525.
- Van Best, J. A., and Duysens, L. N. M. (1975). *Biochim. Biophys. Acta* **408**, 154-163.
- Van Best, J. A., and Mathis, P. (1978). *Biochim. Biophys. Acta* **503**, 178-188.
- Van Gorkom, H. J. (1974). *Biochim. Biophys. Acta* **347**, 439-442.
- Van Gorkom, H. J., and Pulles, M. P. J. (1978). *Abstr. Int. Congr. Photosynth., 4th, 1977* pp. 393-394.
- Velthuys, B. R. (1978). *Proc. Natl. Acad. Sci. U.S.A.* **75**, 6031-6034.
- Velthuys, B. R. (1979). *Proc. Natl. Acad. Sci. U.S.A.* **76**, 2765-2769.
- Velthuys, B. R. (1980a). *Annu. Rev. Plant Physiol.* **31**, 545-567.
- Velthuys, B. R. (1980b). *FEBS Lett.* **115**, 167-170.
- Velthuys, B. R. (1981a). *Proc. Int. Congr. Photosynth., 5th, II*, 75-85.
- Velthuys, B. R. (1981b). *FEBS Lett.* **126**, 277-281.
- Velthuys, B. R. (1982). In "Function of Quinones in Energy Conserving Systems" (B. Trumpower, ed.), Academic Press, New York.
- Velthuys, B. R., and Amesz, J. (1974). *Biochim. Biophys. Acta* **333**, 85-94.
- Vermaas, W. F. J., and Govindjee (1981). *Photochem. Photobiol.* **34**, 775-793.

- Vermeglio, A. (1977). *Biochim. Biophys. Acta*, **459**, 516–524.
- Vermeglio, A., and Clayton, R. K. (1977). *Biochim. Biophys. Acta* **461**, 159–165.
- Vermeglio, A., Breton, J., Barouch, Y., and Clayton, R. K. (1980a). *Biochim. Biophys. Acta* **593**, 299–311.
- Vermeglio, A., Martinet, T., and Clayton, R. K. (1980b). *Proc. Natl. Acad. Sci. U.S.A.* **77**, 1809–1813.
- von Jagow, G., and Engel, W. D. (1980). *FEBS Lett.* **111**, 1–5.
- von Jagow, G., and Sebald, W. (1980). *Annu. Rev. Biochem.* **49**, 281–314.
- von Wettstein, D., Lindberg Møller, B., Hoyer-Hansen, G., and Simpson, D. (1980). In "Origin of Chloroplasts" (J. A. Schiff, ed.), pp. 243–255. Elsevier, Amsterdam.
- Vredenberg, W. J. (1981). *Physiol. Plant.* **53**, 598–602.
- Vredenberg, W. J., and Amesz, J. (1967). *Brookhaven Symp. Biol.* **19**, 49–61.
- Wasserman, A. R. (1980). In "Methods in Enzymology" (A. San Pietro, ed.), Vol. 69, pp. 181–202, Academic Press, New York.
- Webster, G. D., Cogdell, R. J., and Lindsay, J. G. (1980a). *FEBS Lett.* **111**, 391–394.
- Webster, G. D., Cogdell, R. J., and Lindsay, J. G. (1980b). *Biochim. Biophys. Acta* **591**, 321–330.
- Weikard, J. (1968). *Z. Naturforsch., B: Anorg. Chem., Org. Chem., Biochem., Biophys., Biol.* **23B**, 235–238.
- Wherland, S., and Pecht, I. (1978). *Biochemistry* **17**, 2585–2591.
- Whitmarsh, J., and Cramer, W. A. (1977). *Biochim. Biophys. Acta* **460**, 280–289.
- Whitmarsh, J., and Cramer, W. A. (1978). *Biochim. Biophys. Acta* **501**, 83–93.
- Whitmarsh, J., and Cramer, W. A. (1979a). *Proc. Natl. Acad. Sci. U.S.A.* **76**, 4417–4420.
- Whitmarsh, J., and Cramer, W. A. (1979b). *Biophys. J.* **26**, 223–234.
- Whitmarsh, J., and Cramer, W. A. (1980). In "Methods in Enzymology" (A. San Pietro, ed.), Vol. 69, pp. 202–223. Academic Press, New York.
- Whitmarsh, J., Bowyer, J. R., Bouges-Bocquet, B., and Crofts, A. R. (1981). *Abstr. 11th., Steenback Symp., 1981* p. 47.
- Widger, W., Cramer, W. A., Gullifor, M., and Meyer, D. (1982). *Abstr. 8th Midwest Photosyn. Mtg., Argonne, Ill.*; manuscript in preparation.
- Witt, H. T. (1975). In "Bioenergetics of Photosynthesis" (Govindjee, ed.), pp. 493–554. Academic Press, New York.
- Witt, H. T., (1979). *Biochim. Biophys. Acta* **505**, 355–427.
- Witt, H. T., and Moraw, R. (1959). *Z. Phys. Chem. (Wiesbaden) [N.S.]* **20**, 254–282.
- Wood, F. E., and Cusanovich, M. A. (1975). *Arch. Biochem. Biophys.* **168**, 333–342.
- Wood, F. E., Post, C. B., and Cusanovich, M. A. (1977). *Arch. Biochem. Biophys.* **184**, 586–595.
- Wood, P. (1977). *Eur. J. Biochem.* **72**, 605–612.
- Wood, P. (1978). *Eur. J. Biochem.* **87**, 9–19.
- Wood, P. (1980). *Biochem. J.* **189**, 385–391.
- Wood, P. (1981). *Proc. Int. Congr. Photosynth., 5th*, **11**, 591–598.
- Wraight, C. A. (1977). *Biochim. Biophys. Acta* **459**, 525–531.
- Wraight, C. A. (1979). *Photochem. Photobiol.* **30**, 767–776.
- Wraight, C. A., (1981). In "Function of Quinones in Energy Conserving Systems" (B. L. Trumpower, ed.), Academic Press, New York.
- Wraight, C. A., and Crofts, A. R. (1971). *Eur. J. Biochem.* **19**, 386–397.
- Wraight, C. A., and Stein, R. R. (1980). *FEBS Lett.* **113**, 73–77.
- Wraight, C. A., Cogdell, R., and Chance, B. (1978). In "The Photosynthetic Bacteria" (R. K. Clayton and W. Siström, eds.), pp. 471–511. Plenum, New York.
- Yamazaki, I., and Ohnishi, T. (1966). *Biochim. Biophys. Acta* **112**, 469–481.

- Yerkes, C. T., and Babcock, G. T. (1981). *Biochim. Biophys. Acta* **634**, 19–29.
- Yu, Ca., and Yu, Y. (1980). *Biochemistry* **19**, 3579–3585.
- Zanetti, G., and Curti, B. (1980). In "Methods in Enzymology" (A. San Pietro, ed.), Vol. 69, pp. 250–255. Academic Press, New York.
- Zannoni, D., Baccarini-Melandri, A., Melandri, B. A., Evans, E. H., and Crofts, A. R. (1974). *FEBS Lett.* **48**, 152–155.
- Zielinski, R., and Price, C. (1980). *J. Cell Biol.* **85**, 435–445.

Oxygen Evolution in Photosynthesis

THOMAS J. WYDRZYNSKI*

I. Introduction.....	470
II. Substrate.....	470
III. Energetics.....	472
IV. Kinetics.....	473
A. Kinetic Intermediates.....	474
B. Light Activation.....	474
C. Concept of Charge Accumulation.....	476
D. Kinetic Model.....	477
V. Chemistry.....	489
A. Proton Release.....	489
B. Manganese Requirement.....	490
C. Proteinaceous Components.....	497
D. Other Cofactors.....	498
References.....	500

ABBREVIATIONS

B	Secondary electron acceptor in photosystem II
CCCP	Carbonyl cyanide- <i>m</i> -chlorophenylhydrazone
Chl	Chlorophyll
DCMU	3-(3,4-Dichlorophenyl)-1,1-dimethylurea
DCPIP	2,6-Dichlorophenolindophenol
ESR	Electron spin (paramagnetic) resonance
M	O ₂ -evolving intermediate which stores four oxidation charges before reacting to produce O ₂
NMR	Nuclear magnetic resonance
P680	Reaction center chlorophyll <i>a</i> molecule in photosystem II
PQ	Plastoquinone
PRR	Proton relaxation rates
PSI	Photosystem I
PSII	Photosystem II
Q	First stable electron acceptor in photosystem II
S _{<i>n</i>} (<i>n</i> =0,1,2,3,4)	Charge accumulating states of photosystem II as governed by the oxidation level of the O ₂ -evolving intermediate, M
Tris	Trishydroxymethane
Y _{<i>n</i>}	Oxygen yield after a flash number ' <i>n</i> '

*This chapter is dedicated to the memory of my mother.

ABSTRACT

Although the exact chemical nature of the photosynthetic O_2 -evolving reactions still remains unknown, it appears that a manganese protein is involved in it. The O_2 -evolving component cycles through five states upon repetitive photoactivation of photosystem II. The cycling of the states most likely involves manganese oxidation state changes as well as changes in the oxidation level of bound water molecules. Other cofactors necessary for O_2 evolution include chloride and calcium ions. However, the function of these ions in the reactions is still unknown. Advances in the isolation and characterization of membrane components associated with photosystem II promises to lead to a much better understanding of the O_2 -evolving process in the near future.

I. Introduction

The intent of this chapter is to give a general overview to the problem of O_2 evolution in photosynthesis. Although various aspects of O_2 evolution have been reviewed in detail previously (Kok and Cheniae, 1966; Cheniae, 1970; Joliot and Kok, 1975; Radmer and Kok, 1975; Diner and Joliot, 1977; Radmer and Cheniae, 1977; Velthuys, 1980; Govindjee, 1980; Renger and Eckert, 1981), the main goal here is to emphasize the fundamental concepts, particularly in context with more recent findings. An attempt is made to summarize what is known of the energetics, kinetics, and chemistry of the reactions involved.

II. Substrate

That plants can "improve the quality of air," that is, produce O_2 , was first discovered by Joseph Priestly (1776). The involvement of light, CO_2 , water, and the chlorophylls in the process was later recognized and overall photosynthesis was formulated simply as follows:

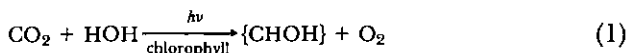

where $\{CHOH\}$ represents one unit of fixed carbon. In this generalized view of photosynthesis, the substrate from which O_2 is derived could be either CO_2 or water.

Many of the early theories on photosynthesis considered a chlorophyll- CO_2 complex to be the immediate precursor to O_2 (Willstätter and Stoll, 1918; Gaffron and Wohl, 1936; Franck and Herzfeld, 1937). However, the idea that photosynthetic O_2 comes from water was also considered (Berthelot, 1864; Wurmser, 1930; see Rabinowitch, 1945,

for a review of the early literature). Comparative biochemical studies of plant and bacterial photosynthesis (van Niel, 1931; see Chapter 2, this volume) and the discovery that O_2 evolution can be isolated from organic synthesis (Hill and Scarisbrick, 1940) tended to support a water substrate hypothesis. However, the strongest experimental evidence came from the ^{18}O labeling measurements of Ruben *et al.* (1941). In these experiments the ^{18}O content of the O_2 produced by *Chlorella* cells was found to be identical to the ^{18}O content of the suspension water and independent of the initial ^{18}O content of added carbonate. This result was taken, at the time, as conclusive proof that photosynthetic O_2 indeed comes from water.

Some 20 years after the experiments of Ruben *et al.*, Warburg re-introduced Wilmstätter's idea that CO_2 could be the source of O_2 . He found that bicarbonate ions are a necessary requirement for O_2 evolution, independent of the CO_2 fixing reactions (Warburg and Krippahl, 1960). In a review of the original experiments of Ruben *et al.*, Warburg (1964) argued that ^{18}O labeling measurements could not accurately discriminate the true substrate for photosynthetic O_2 because of rapid exchange reactions in water carbonate mixtures, that is,



In particular, mixing of the oxygen isotopes via the preceding reactions would be facilitated by low pH and the enzyme carbonic anhydrase, conditions which could not be controlled in the algal suspensions that were used in the original experiments. Based on a bicarbonate requirement for O_2 evolution, Warburg (1964) proposed instead that a specially bound CO_2 molecule or "photolyte" is the direct precursor to photosynthetic O_2 .

In a quest to identify the true substrate for O_2 , Stemler and Radmer (1975) repeated the ^{18}O labeling experiments. For their samples they used broken thylakoid membranes which showed no significant carbonic anhydrase activity and which were regulated in pH to minimize the exchange reactions. The thylakoids were first depleted in bicarbonate and the ^{18}O label was added as $HC^{18}O_3^-$. The results showed that all O_2 produced in the first 3–9 min of illumination comes from the ^{16}O in the water and not from the ^{18}O in the bicarbonate, thus supporting the original observations of Ruben *et al.* In more recent measurements Radmer and Ollinger (1980) showed that the ^{18}O distribution of the O_2 produced even in microsecond light flashes is also identical to that of labeled water and not of labeled bicarbonate. Clearly, in these experiments, water is the ultimate source of O_2 .

By contrast, Metzner *et al.* (1979) found the ^{18}O content of the O_2

produced by an unenriched suspension of *Ankistrodesmus* cells to be somewhat higher than was expected from the natural abundance ^{18}O of the surrounding water. Such an isotope discrepancy could indicate that water is not the immediate precursor to photosynthetic O_2 (Metzner, 1975). However, the isotope difference in Metzner's measurements was small (0.199% experimental versus 0.197% expected) and may have been caused by contributions from other, additional O_2 producing and/or consuming reactions of the cells.

The evidence for CO_2 (HCO_3^-) or a specially bound carbon photolyte as substrate for photosynthetic O_2 is therefore minimal at this time. This becomes particularly evident when consideration is given to other data, which suggests that the major effect of CO_2 (HCO_3^-) discovered by Warburg is located on the electron acceptor side of photosystem II (PSII) and not on the O_2 -evolving reactions (Govindjee and van Rensen, 1978; Vermaas and Govindjee, 1981a). However, one cannot completely exclude the possibility that CO_2 (HCO_3^-) serves some catalytic role in the O_2 -evolving reactions (Stemler, 1980). But the concept that water is the direct precursor to photosynthetic O_2 is the underlying thesis of this chapter. For further details on the role of CO_2 (HCO_3^-) in PSII the reader is referred to A. Stemler (Chapter 15) and W. Vermaas and Govindjee (Chapter 16) in Volume II of this series (Govindjee, 1982).

III. Energetics

Water decomposition can be described by the following reversible reaction:



where the net change in the total energy for the reaction is 114.2 Kcal/mole or 4.952 eV (Ohta, 1979). To form one O_2 molecule from water requires four charge transfer steps; thus, an average energy input of 1.238 eV per step is required. In O_2 -evolving plants, the chlorophyll (Chl) *a* molecules, which drive photosynthesis, can absorb photons with a minimum energy of 1.8 eV. This energy appears to be sufficient to drive the stepwise breakdown of water. Indeed, O_2 flash yield measurements indicate that photosynthetic O_2 evolution is a four step process (see Section IV,D).

The preceding discussion is too simplistic, however, since the energy balance for Eq. (3) is applicable for a reversible reaction. For irreversible reactions, such as those involving dissolved gases, an appreciable extra

energy input is often required to overcome entropic heat losses. An example of this is the overvoltage in an electrochemical process. In water electrolysis, the minimum overvoltage was found to be 0.42 V, so that each charge transfer step in the breakdown of water requires a minimum average potential of 1.65 V (Hoare, 1968). In photosynthetic O_2 evolution from water, the required "overvoltage" may be considerably less, but not negligible and hence add to the energy requirement. Another consideration is that H_2 gas is not a product of photosynthetic water splitting. Instead, some intermediates serve as hydrogen carriers (e.g., plastoquinone), which are then utilized in subsequent reductive reactions. The breakdown of water in photosynthesis is thus considered to be an oxidation process rather than a direct photolysis.

Despite the lack of precise chemical and thermodynamic data on photosynthetic O_2 evolution, overall thermodynamic considerations do place limits on the types of reaction pathways that may be involved (see, e.g., Duysens, 1958; Ross and Calvin, 1967; Knox, 1969; and Parson, 1978). It may be argued that a stepwise-oxidation of water may not occur and that the energy from at least two photoacts, and possibly three, is needed to cause even a partial oxidation of water in photosynthesis (see, e.g., Arnason and Sinclair, 1976a, b; Renger, 1977, 1978). However, there are other indications (see Sections V,A and B) that partial oxidation of water may begin even in the first step. What is clear, however, is that O_2 is not evolved until at least three photoacts have taken place. This implies the need for a cooperative mechanism linking individual photochemical reactions. The significance of this concept becomes apparent with the postulation of a charge storage mechanism, which is described in the following sections. For further details on the thermodynamics of water splitting in general, the reader is referred to the book edited by Ohta (1979).

IV. Kinetics

Much of what is known about the mechanism of O_2 evolution has come from kinetic studies, particularly those under flashing light conditions. The detailed kinetics are covered in several excellent reviews (Joliot and Kok, 1975; Radmer and Kok, 1975; Diner and Joliot, 1977; Radmer and Cheniae, 1977; Velthuys, 1980). In the following sections the basic concepts that have emerged up to this time are presented, along with the possible ramifications of recent findings. In any attempt to develop a chemical model for O_2 evolution, the kinetics must first be reconciled.

A. Kinetic Intermediates

The first studies of O₂ evolution in flashing light were the classic experiments of Emerson and Arnold (1932). They subjected *Chlorella* cells to repetitive brief (10 μsec) saturating flashes of light so that only photochemical conversions would take place and measured the total O₂ produced. When the dark period between the flashes was chosen to give the maximum O₂ yield, a maximum value of about one O₂ molecule per 2500 chlorophyll molecules was obtained. The flash yield decreased to half maximum at a dark time of ~ 10 msec at 20°C. Emerson and Arnold concluded that several hundred Chls worked together in a unit to collect light energy and to photochemically form a "long-lived" intermediate, which promotes the production of O₂. They assumed that the formation of this intermediate was catalyzed by an "enzyme" present at low concentrations and that this was the rate-limiting step in photosynthesis. (It is now known that the rate-limiting step in the photosynthetic electron transport chain is the reoxidation of plastoquinone, see Cramer and Crofts, Chapter 9, this volume.)

The dependence of the flash yield upon the dark time between flashes, however, proved to be more complex than the simple first-order kinetics assumed by Emerson and Arnold. And it was found later that flashes longer than 20 μsec but shorter than the half-time of the dark reaction produced considerably higher yields than expected (Kok, 1956). This led to the idea that at least two intermediates must be involved. Accordingly, light would excite an intermediate P:



which would be rapidly discharged by another intermediate *E* at the same concentration as P:



The E* intermediate would then facilitate O₂ evolution. The large yields of long flashes could then be explained by a multiple turnover of the first intermediate.

B. Light Activation

Allen and Franck (1955) were the first to measure the O₂ produced by a single flash of light. They observed that no O₂ was produced in dark-adapted anaerobic *Scenedesmus* cells using a flash of <1 msec duration. But O₂ could be observed when (1) a weak background light was

given in the dark period preceding the flash; (2) two brief flashes were given spaced 1 sec apart; or (3) long flashes (~ 25 msec) were used.

Whittingham and Brown (1958) confirmed and extended these measurements with the alga *Ankistrodesmus*. Flashes of ≤ 5 -msec duration gave no observable O_2 , whereas longer 35-msec flashes did. With a 100-msec flash preceding a long flash, the yield of O_2 produced was twice as great as that with the long flash alone. However, the maximum enhancement of the O_2 yield occurred only when a certain dark time was interposed between the flashes. The yield increased to a maximum at 0.7 sec dark time and then slowly declined at longer dark times. Whittingham and Brown interpreted their results to mean that the first single flash was required to light activate some catalyst needed for O_2 evolution and that it must stabilize in the dark before it could be used to catalyze O_2 evolution upon the next flash. To account for these results Eqs. (4) and (5) can be expanded as follows:

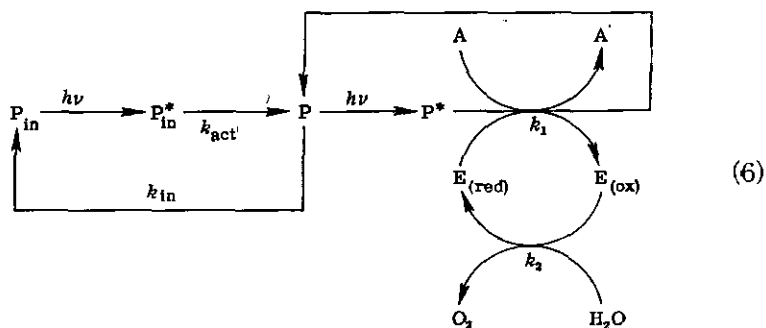

Here, P is the active form of the first intermediate, P_{in} , a dark inactivated form, P^*_{in} and P^* , light-induced states, $E_{(red)}$ and $E_{(ox)}$, the reduced and oxidized forms of the O_2 -evolving intermediate, k_{act} , the rate constant for dark stabilization of the light-induced form P^*_{in} , k_{in} , the rate constant for dark inactivation, k_1 , the rate constant for the formation of $E_{(ox)}$ from $E_{(red)}$, k_2 , the rate constant for the actual O_2 -evolving step, and A , some other intermediate reduced during the process (which eventually leads to the reduction of CO_2 or a Hill oxidant). Thus, according to this scheme light is first required to activate P_{in} to P , which requires a finite dark time for stabilization. The active form P can then be converted by another light quantum into P^* , which promotes the evolution of O_2 via the intermediate E in the dark. As a consequence A is reduced as $E_{(red)}$ is oxidized. The light-activated capacity to evolve O_2 is lost in the dark after sufficient time if not driven forward by another incoming quantum.

C. Concept of Charge Accumulation

Whittingham and Bishop (1963) assumed that the light activation process was the priming of photosystem II for O_2 evolution by photosystem I. However, Joliot (1965) showed that the activation step is sensitized only by PSII. Using a more sensitive O_2 electrode (see Joliot and Joliot, 1968), he measured the time course for O_2 evolution in weak (modulated) light. Under these conditions for samples that are dark-adapted, the O_2 curve (i.e., yield versus time of illumination) displays a lag and then a rapid rise in the yield. The lag corresponds to the light activation process, while the initial slope of the O_2 rise measures the rate for the dark stabilization of the light-induced form of P_{in} , that is,



When Joliot illuminated samples with monochromatic light, he found the shape of the O_2 curve to be independent of wavelength. Therefore, he concluded that PSI is not involved in the light activation process.

For samples that are preactivated (i.e., preilluminated) before measurement of the O_2 yield in weak light, the O_2 curve does not show a lag, but only a rise in the yield. The initial slope of the O_2 rise in this case measures the rate of dissipation of the light-induced form of P by the O_2 -evolving step, that is,

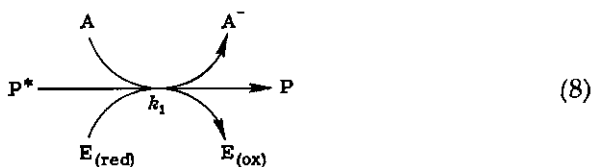

Surprisingly, Joliot found that the initial slope of the O_2 rise for preilluminated samples was the same as the initial slope of the O_2 rise for dark-adapted samples. He concluded that $k_{act} = k_1$ and that both the activation step and the O_2 -producing step must involve a reaction with the same intermediate, i.e., A .

Since the reaction of P^* with A leads to a reduction of A , then the reaction of P_{in}^* with A must also lead to a reduction of A . This led Kok and Cheniae (1966) to suggest that there must be some reaction partner, which they called M (E in the above scheme), that is photo-oxidized at least twice, once to M^+ during the activation process and a second time to M^{2+} during the O_2 -evolving step. This was one of the first proposals for a charge accumulating mechanism as part of the O_2 -evolving process.

D. Kinetic Model

Further refinements in the O_2 flash yield measurements revealed other complexities in the O_2 kinetics. Specifically, it was found that when the O_2 is measured after each flash in a series of flashes, a unique oscillatory pattern is obtained (Joliot *et al.*, 1969; Kok *et al.*, 1970). Typical results are shown in Fig. 1. No O_2 is produced after the first flash, whereas very little is produced after the second flash. The maximum O_2 yield occurs after the third flash. Thereafter, the O_2 yields follow a basic periodicity of 4 peaking around the seventh, eleventh, etc., flashes, until the oscillations damp out to a steady state value. Several mathematical models have been proposed to explain these unique patterns (Joliot, 1968; Joliot *et al.*, 1969; Kok *et al.*, 1970; Forbush *et al.*, 1971; Mar and Govindjee, 1971; Lavorel, 1976a; Greenbaum, 1977; Thibault, 1978a, b; Jursinic, 1979). However, the model as proposed by Kok and co-workers (Kok *et al.*, 1970; Forbush *et al.*, 1971) provides the best working hypothesis at this time and will be used as a focal point in the following discussions.

To account for the periodicity of 4, Kok assumed that each O_2 -evolving center cycles through five different states (S_n) upon activation by successive light flashes, that is,

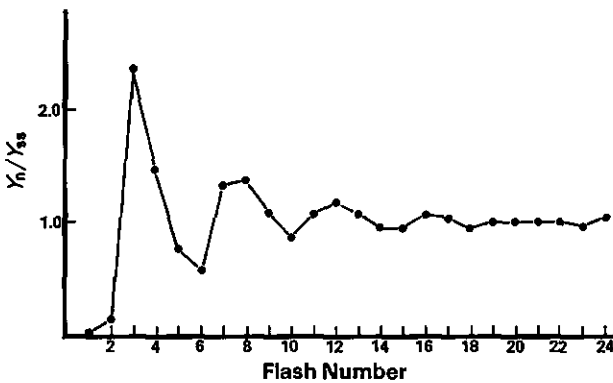
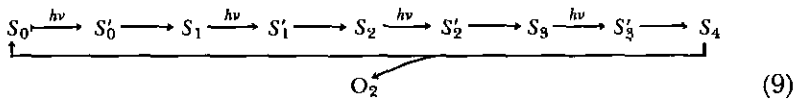
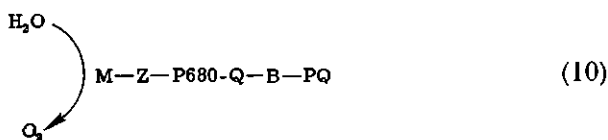

FIG. 1. O_2 yield measured as a function of number of saturating light flashes for a sample of dark-adapted pea thylakoids. The O_2 yield after a given flash (Y_n) is normalized to a steady state value of unity ($Y_{ss} = 1$).

with O_2 being released only on the $S_4 \rightarrow S_0$ transition. The $S'_n \rightarrow S_{n+1}$ transitions represent the recovery reaction for the O_2 -evolving center, i.e., the time needed after excitation before a center may effectively utilize a second photon. Since the light activation steps must involve photo-oxidation reactions (Section IV,C). Kok concluded that each S_{n+1} state differs from the preceding S_n state by one positive charge equivalent. Interestingly, the periodicity of 4 in the O_2 flash patterns implies the involvement of 4 charge transfer reactions. This is exactly what is needed to produce O_2 from water and is one of the strongest arguments for a water decomposition mechanism (Section II).

Although S was originally described as a state of the O_2 -evolving center, meaning PSII and its associated parts, in the current literature it is often used to denote a distinct chemical intermediate. In this chapter M will be used to indicate the specific oxygen-evolving intermediate that can store up to 4 oxidizing charges (i.e., M^+ , M^{2+} , M^{3+} , M^{4+}) while S_n will be used to indicate the state of PSII as governed by the oxidation level of M . The letter M replaces the E intermediate used in the early literature and in the preceding sections. Thus, the minimal model for PSII may be given as follows (see Parson and Ke, Chapter 8, and Cramer and Crofts, Chapter 9, in this volume):



where P680 is a special Chl a molecule that is photo-oxidized, Q is the first stable electron acceptor (which is a quinone type molecule and also referred to as Q_A , Q_1 , or X-320), Z is an electron donor to P680, B is a secondary electron acceptor (which is a quinone-type molecule and also referred to as Q_B , Q_{IP} or R) that connects PSII to the plastoquinone pool (PQ) and PSI, and M is the charge accumulating intermediate that reacts to produce O_2 . In this picture, the state S_0 would be equivalent to $M \cdot Z \cdot P680 \cdot Q$, S_1 to $M^+ \cdot Z \cdot P680 \cdot Q$, and so on.

To explain the various kinetic features of the O_2 flash patterns the following assumptions have to be made: (1) each S_n state transition is a one quantum process, all centers acting independently of each other; (2) there is a small fraction (β) of the O_2 -evolving centers that advances two states during a light flash by a "double hit" while another fraction (α) of the centers fails to advance because of a "miss"; (3) the S_0 and S_1 states

are stable in the dark; and (4) the S_2 and S_3 states deactivate to S_1 . In the following sections the significance of the model is discussed in some detail.

1. INDEPENDENCY OF CENTERS

Joliot *et al.* (1969) first observed that the depth of flash oscillations in the O_2 yield was very small (<5%) if the sample was given a brief preillumination with continuous light prior to flash excitation. In terms of Kok's model, this would mean that the concentrations of individual S_n states are the same under steady state conditions, that is, $\{S_0\}_{ss} = \{S_1\}_{ss} = \{S_2\}_{ss} = \{S_3\}_{ss}$, where the concentration of S_4 is negligible since it rapidly reacts to produce O_2 and the S_0 state. Joliot concluded that each step in the O_2 mechanism must have the same quantum efficiency. Subsequently, Kok *et al.* (1970) showed that in weak, nonsaturating light flashes the O_2 flash yield was linearly dependent upon the flash intensity. Since the O_2 produced after a flash monitors only the final O_2 -evolving step directly, Kok concluded that this step is a one-quantum process. Thus, based on Joliot's results, each step in the O_2 mechanism must be a one-quantum process.

The fact that the O_2 yield does oscillate indicates that each O_2 -evolving center must accumulate charge independently of its neighbors. Consequently, a loss in the number of active O_2 -evolving centers should not affect the flash yield pattern. Indeed, this was found to be the case when DCMU, UV irradiation or Mn depletion were used to decrease the number of active O_2 -evolving centers. Under these conditions, the same extent of inhibition was observed for all flash yields, even though the amplitudes were decreased as much as 10-fold (Kok *et al.*, 1970). Similar results were obtained with a mutant of *Chlamydomonas* having a limited population of active O_2 centers (Joliot *et al.*, 1973). Thus, O_2 -evolving centers show very little, if any, cooperativity at the level of charge accumulation. The concept of noncooperativity was one of the major reasons for the acceptance of Kok's four-step mechanism.

2. PHOTOSYSTEM II TURNOVER

After light activation, each S_n state must undergo a finite dark relaxation before it can be activated by another incoming quantum, i.e., the $S'_n \rightarrow S_{n+1}$ transition in Eq. (9). In terms of the model for PSII in Eq. (10) the relaxation of S'_1 to S_2 would correspond to the conversion of $M^+ \cdot Z \cdot P680^+ \cdot Q^-$ to $M^{2+} \cdot Z \cdot P680 \cdot Q$ with the electron going on to B. The first measurements of these dark relaxations were made by Kok *et al.* (1970). For the $S'_1 \rightarrow S_2$ and $S'_2 \rightarrow S_3$ transitions they obtained $t_{1/2}$ of

~ 0.2 msec and ~ 0.4 msec, respectively. Somewhat different results were obtained by Bouges-Bocquet (1973a). In her measurements, both the $S'_0 \rightarrow S_1$ and $S'_1 \rightarrow S_2$ transitions showed nonexponential kinetics and a $t_{1/2}$ for both transitions of ~ 0.4 msec. The nonexponential behavior remained even with nonsaturating light flashes, indicating that this was inherent to the O_2 mechanism. The $S'_2 \rightarrow S_3$ transition, on the other hand, showed sigmoidal kinetics with an initial lag of ~ 0.1 msec. Bouges-Bocquet suggested that this transition may be limited by two first-order reactions and that another transitory state (S'_2'') perhaps existed.

In contrast to the other relaxations steps, the $S'_3 \rightarrow S_4 \rightarrow S_0$ transition follows first-order kinetics and proceeds at a much slower rate. This step is associated with the release of O_2 and represents the overall rate-limiting reaction. Joliot *et al.* (1966) first measured the rate constant for this step and obtained a value of 820 sec^{-1} ($t_{1/2} = 0.84$ msec). But other determinations of the rate constant include $\sim 300 \text{ sec}^{-1}$ ($t_{1/2} = 2.31$ msec) (Etienne, 1968; Sinclair and Arnason, 1974) and 580 sec^{-1} ($t_{1/2} = 1.19$ msec) (Bouges-Bocquet, 1973a). An Arrhenius plot of the rate constant over $8\text{--}42^\circ\text{C}$ temperature range is linear (Sinclair and Arnason, 1974), indicating that only one rate-limiting step is involved. The calculated activation energies range from $0.257\text{--}0.345$ eV (Joliot *et al.*, 1966; Etienne, 1968; Sinclair and Arnason, 1974).

The relaxation of each S'_n state ultimately depends upon the recovery of the PSII reaction center [Eq. (10)]. The reduction of $P680^+$ follows multiphasic kinetics. A fast component with $t_{1/2}$ from 30 nsec to 3 μsec (depending upon the plant material and illumination state of the sample, see Parson and Ke, Chapter 8; Cramer and Crofts, Chapter 9, this volume) accounts for 75–80% recovery of $P680$, whereas two slower components, $t_{1/2} \sim 35 \mu\text{sec}$ and $t_{1/2} \sim 200 \mu\text{sec}$, account for the rest (Gläser *et al.*, 1974). On the other hand, the transfer of negative charge from Q to B is much slower, with $t_{1/2} \sim 400 \mu\text{sec}$ (Zankel, 1973). Thus, it is usually assumed that under most conditions the $S'_0 \rightarrow S_1$, $S'_1 \rightarrow S_2$ and $S'_2 \rightarrow S_3$ transitions are rate-limited by the reoxidation of Q^- . In contrast the $S'_3 \rightarrow S_4 \rightarrow S_0$ transition is rate-limited by the reactions leading to the release of O_2 .

3. DAMPING MECHANISMS

To account for the damping in the O_2 flash yield oscillations, Forbush *et al.* (1970) proposed two perturbations—double hits and misses. Double hits would tend to advance, whereas misses would tend to retard the stepwise conversion of the S_n states during a flash sequence.

The effect of double hitting on the O_2 mechanism must necessarily depend upon the PSII turnover rates. Thus, as the flash duration

changes so should the probability of double hits. The extent of double hitting can be estimated by the O_2 yield after the second flash (Y_2). In the 10- μ sec xenon flashes typically used in O_2 flash yield measurements, a small but significant Y_2 is always observed. Double hits are calculated to occur in about 5% of the O_2 -evolving centers (Forbush *et al.*, 1971). With shorter 2- μ sec flashes spaced 320 msec apart (Joliot *et al.*, 1971) or with 40-nsec laser pulses spaced 15 sec apart (Weise and Sauer, 1970), no O_2 was observed on the second flash and double hits were assumed to be negligible. With longer 20- μ sec xenon flashes, the double hits were calculated to be about 10% (Wydrzynski and Sauer, 1980).

However, since PSII turnover rates depend upon any number of charge transfer steps, the extent of double hitting may not be the same under all conditions. For example, in 2- μ sec light flashes the Y_2 was found to be pH dependent. It was much greater at a pH of < 7.0 in glutaraldehyde treated *Chlorella* cells (Maison-Peteri, 1980) and in chloroplasts (Maison-Peteri, 1981). Also in the presence of low concentrations of ferricyanide and 200 mM $MgCl_2$, an increase in Y_2 was observed (Velthuys and Kok, 1978a). But in very brief light flashes where the relative PSII turnover rates would be slow enough in comparison with the pulse duration to exclude double hitting, double hits as monitored by O_2 flash yield measurements can still be observed. Jursinic (1981) found that using 5-nsec laser pulses spaced 500 nsec apart, a significant O_2 yield is present after the second flash when he used freshly prepared thylakoid samples. However, in aged or frozen samples, the O_2 yield after the second flash was absent. To explain these results, Jursinic suggested that there are two types of double hits: 1) a nonphotochemical type which is an inherent property of PSII; and 2) a photochemical type which depends upon the PSII turnover rates and hence the time structure of the exciting pulse. Assuming that the nonphotochemical double hits are sensitive to the physiological state of the sample, they would account for the O_2 yield after the second flash in some samples and not others in nanosecond light pulses.

PSII measurements of dark-adapted samples, in which the reaction centers have completely relaxed, indicate that significantly more double hits occur in PSII in microsecond flashes than samples which are light-adapted (Glaser *et al.*, 1976; Joliot and Joliot, 1977; Bowes *et al.*, 1979; Joliot and Joliot, 1981). Interestingly, under the conditions that allow a greater occurrence of double hits in PSII, the additional positive charges that are generated do not appear to activate the O_2 mechanism (Diner, 1977; Eckert and Renger, 1980). The double hits in this situation are explained by the existence of additional charge carriers in PSII. Although more explicit models are proposed (see Bouges-Bocquet, 1980,

for a review), the model of Eq. (10) can be expanded in the following ways:

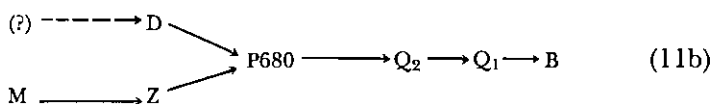

An additional electron acceptor, Q_2 , is proposed to be either in parallel [Eq. (11a)] or in series [Eq. (11b)] with the main path of electron flow. A double hit, which may or may not be related to the double hits observed by O_2 flash yield measurements, can occur by Eq. (11a) as follows. The first excitation during the light pulse causes the initial charge separation: $P680 \cdot Q_1 \rightarrow P680^+ \cdot Q_1^-$, followed by electron flow from Z to $P680^+$, with a half-time of ~ 20 nsec. A second excitation then occurs within the time of the flash duration, causing another charge separation (double hit): $P680 \cdot Q_2 \rightarrow P680^+ \cdot Q_2^-$, followed by electron flow either from Z (which would charge up the O_2 -evolving system) or from another electron donor D (which would not charge up the O_2 -evolving system) to $P680^+$. If the model in Eq. (11b) would be operative, the first excitation causes the initial charge separation: $P680 \cdot Q_2 \rightarrow P680^+ \cdot Q_2^-$, followed by electron flow from Z to $P680^+$ and from Q_2^- to Q_1 . The reaction center recovers quickly and the second excitation cause another charge separation (double hit): $P680 \cdot Q_2 \rightarrow P680^+ \cdot Q_2^-$. The reduction of $P680^+$ then occurs either by electron flow from Z or D as for the model in Eq. (11a). The series model requires that Q_2 be reduced and oxidized very rapidly during the microsecond light pulse. There is evidence that an intermediate (possibly a pheophytin molecule) exists before Q_1 that undergoes very rapid reduction upon photo-oxidation of P680 (Klimov *et al.*, 1978); however, the extremely fast back reaction between $P680^+$ and the reduced form of this intermediate ($t_{1/2} \sim 3$ nsec) excludes the possibility that it is Q_2 (Vermaas and Govindjee, 1981b). The dissipation of the additional positive charges that do not activate the O_2 system would be explained by the existence of another secondary donor, D, not connected to M, or else by a rapid back reaction between Z and Q.

In view of the complexities in PSII, the contributions of double hits to the O_2 mechanism may not be completely ignored under all conditions as had previously been done. Nevertheless, it is probably still safe to assume that the other damping mechanism—misses—is the major mode

for mixing of the S_n states during a flash sequence. The frequency of misses is calculated to be about 10% in isolated chloroplast membranes from higher plants and about 20% in intact algal cells. The percentage of misses remains constant at flash intensities far above saturation indicating that misses are an inherent property of the system.

Misses can be explained either as (1) the failure of the charge separation to take place at the reaction center; or (2) the annihilation of the charge prior to its use in O_2 evolution. With regard to the first explanation, the recovery times for the primary electron donor and acceptor are much faster than the 1–2 sec dark times typically used in flash sequences, so that the failure of charge separation to take place because the reaction center remains closed may not be likely, although as pointed out earlier, PSII turnover rates strongly depend upon the sample and experimental conditions. However, the charge separation may not take place because other deactivation processes effectively compete with the primary photochemistry or because the reaction center becomes temporarily disconnected from the light-harvesting complex and a light quantum never reaches the reaction center. But at this time, there is no strong experimental evidence for these possibilities.

On the other hand, luminescence (delayed light emission) measurements have provided some experimental support for the preceding second explanation. The microsecond Chl luminescence observed in photosynthetic systems is interpreted as arising from a back reaction between $P680^+$ and Q^- (see a review by Govindjee and Jursinic, 1979). Interestingly, it was found to oscillate with a period of 4 in a sequence of light flashes, as though it were being modulated by the S_n states (Zankel, 1971). Misses could thus arise from a rapid back reaction at some of the centers. However, the yield of luminescence is extremely small and may not comfortably satisfy the high percentage of misses that occur. One could predict that most of the high energy states created by charge recombination at the reaction center is dissipated by deactivation processes other than luminescence emissions.

Alternatively, misses may arise from the annihilation of the charge at one of the secondary electron donors or at the M intermediate itself. However, loss of charge at these steps would have to involve a reaction with the reduced primary or secondary acceptors. The secondary electron acceptor, B, is a two-electron carrier and was shown to oscillate in a microsecond flash sequence, but with a binary periodicity (Bouges-Bocquet, 1973b; Velthuys and Amesz, 1974). The damping in the B oscillations is similar to the damping in the O_2 yield oscillations (Bouges-Bocquet, 1980). Thus, any charge loss on the donor side of PSII must coincide with charge loss on the acceptor side.

In their original analysis, Forbush *et al.* (1971) assumed that the percentage of misses was the same for each of the S_n state transitions. However, Forbush *et al.* pointed out that this may not necessarily be the case. Using a matrix formulation, Delrieu (1974) was able to show a better theoretical fit to the data if she assumed 0 miss parameters on the $S_0 \rightarrow S_1$ and $S_1 \rightarrow S_2$ transitions and large miss parameters on the $S_2 \rightarrow S_3$ ($\alpha = 0.542$) and $S_3 \rightarrow S_4 \rightarrow S_0$ ($\alpha = 0.20$) transitions.

Extending Delrieu's analysis, Lavorel (1976a) derived a generalized recurrence law for the damping in the O_2 yield oscillations. He concluded that the system becomes underdetermined if misses are different for each of the S_n state transitions, and thus it would be impossible to calculate the individual miss parameters. However, in a different mathematical analysis, Thibault (1978a) concluded that Lavorel's generalization was not necessary and that Kok's original assumption that misses are homogenous on all S_n state transitions was still valid. But in order to make this conclusion, Thibault had to exclude the contribution of the first flash in his analysis, indicating a further complexity in the first-flash kinetics.

If misses are assumed to be only of photochemical origin, then as the percentage of misses increase, the quantum yields at steady state must necessarily decrease. Lavorel (1976b) pointed out (what has been known for a long time) that in intact cells the O_2 oscillations damp out faster than in isolated chloroplasts, although the quantum yield is higher in the former. To explain this, Lavorel (1976b) proposed a model in which the O_2 -evolving M intermediate is mobile with respect to the reaction center complex (P). The M intermediate may accept charge from a reaction center after binding with it, that is,

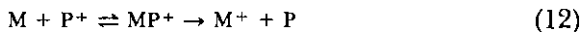

The M intermediate may thus interact with more than one reaction center. The results in intact cells can be explained if the number of M intermediates is greater than the number of reaction centers, whereas the results in isolated chloroplasts can be accounted for if the reverse situation is assumed. However, this model is in direct contradiction to the principle of noncooperativity (Section IV,D,1). It is also incompatible with the results on O_2 measurements of inside-out thylakoid vesicles (Andersson *et al.*, 1977; Andersson and Åkerlund, 1978) unless the mobility of M is restricted to within the membrane. On the other hand, Diner (1974) concluded from results on O_2 flash yield measurements at low light intensities that a limited cooperativity between PSII units may occur under some conditions, but that the charge exchange takes place

between the secondary electron acceptors and donors and not at the M intermediate.

Another model proposed by Lavorel and Lemasson (1976) suggested that a lateral charge carrier (C) exists which can reversibly exchange and store charge with the M intermediate, that is,

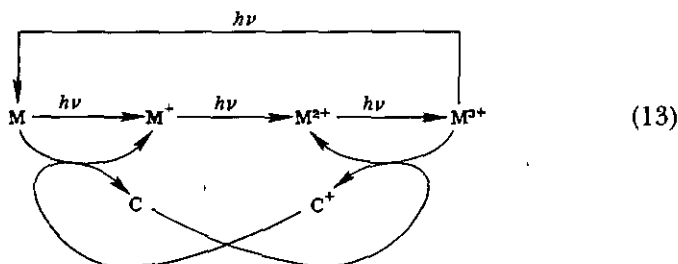

In this model damping is controlled by the relative amount of C to the M intermediate. ESR measurements indicate that free radicals, which accept charge from the S_2 and S_3 states, do exist (Babcock and Sauer, 1973a, b); however, the charge exchange is irreversible. In view of the recent proposals for several secondary electron donors and acceptors in PSII, this model may still be a valid alternative. This model can also explain nonphotochemical double hits proposed by Jursinic (1981). If Lavorel's models for nonphotochemical misses are excluded based on the noncooperativity principle, then there is no reasonable explanation at this time for the damping-quantum efficiency anomaly.

As an alternate explanation for the observed damping of the O_2 flash yield oscillations, Renger (1970, 1978) suggested that structural rearrangements of the charge storage groups on the M intermediate are involved. Several thermoluminescence bands have been associated with the oxidizing side of PSII and the S_n state transitions (Inoue *et al.*, 1976). Temperature studies of the thermoluminescence bands have been used to deduce the temperature dependency of the S_n state transitions. It was suggested that the $S_0 \rightarrow S_1$ and $S_1 \rightarrow S_2$ transitions can proceed at -65°C and below, whereas the $S_2 \rightarrow S_3$ transition is prevented below -35°C and the $S_3 \rightarrow S_4$ transition is prevented below -20°C . Since the binding of water is blocked below -10°C (probably the freezing point of water in thylakoid membranes), it was suggested that the S_n state transitions involve conformational changes, which could be related to structural rearrangements on M, that are variously blocked at low temperatures (Inoue and Shibata, 1978; Inoue, 1981; see Chapter 11, this volume).

4. STABILITY OF INTERMEDIATE STATES

In order to explain why the O_2 yield is maximum after the third flash and not the fourth flash, Kok *et al.* (1970) had to postulate that S_1 was stable in the dark. One of the arguments used to support this assumption is that the $S_1:S_0$ ratio can be varied by appropriate preillumination. During steady state, all the four S_n states (S_0-S_3) are equally distributed. Assuming that only S_2 and S_3 deactivate to S_1 , then after a long dark period the distribution of S_n states should be 3 $S_1:1 S_0$. If one preflash is given and a sufficient dark time allowed, then all centers will deactivate to S_1 . Likewise, three preflashes will convert most centers to S_0 .

Neglecting misses and double hits, the ratio of O_2 yield on the third (Y_3) to the fourth flash (Y_4) is determined completely by the initial S_n state distribution, that is, $Y_3:Y_4 \approx S_1:S_0$. When Forbush *et al.* (1971) did the preceding preillumination experiments, they obtained the following results:

1. $Y_3:Y_4 = 1.58$, with no preillumination
2. $Y_3:Y_4 = 2.37$, with 1 preflash
3. $Y_3:Y_4 = 1.33$, with 3 preflashes

With 1 preflash, there appears to be more S_1 in the dark than with no preillumination and with 3 preflashes there appears to be less S_1 . Thus, they concluded the S_1 is stable in the dark (at least during the dark times they used, i.e., 10 min).

Bouges-Bocquet (see Joliot and Kok, 1975), using the same procedure but with much longer dark times (60 min) between preflashes and measuring flashes, observed that $Y_3:Y_4$ after 1 preflash was quite close to the no preflash condition. This was interpreted to mean that the S_0 and S_1 eventually equilibrate after long dark times to a final dark distribution of 3 $S_1:1 S_0$.

The stability of the S_1 state in the dark is perhaps the most unsatisfactory assumption in the Kok model. Why should a state with one more oxidizing equivalent than S_0 be as stable as S_0 ? Doschek and Kok (1972) examined the alternative possibility that the peak on Y_3 is caused by a double transition on the first flash, but their fluorescence measurements of the acceptor side of PSII failed to support this. However, Thibault (1978b) has shown that the O_2 flash yield results do give a better fit to a model having a large double hit probability ($\sim 60\%$) on the first flash and all centers starting out in S_0 . But the data of Diner (1977) and Eckert and Renger (1980), showing that the excess positive charges generated by a large number of double hits on the first flash do not activate M, does not support this model. In addition, Thibault's model is inconsistent

with the extent of double turnover in PSII in the presence of ferricyanide as measured by the reduction in the area above the fluorescence rise curves (Jursinic, 1981).

Bouges-Bocquet (1973a) first showed that the $Y_3:Y_4$ ratio may be changed by the addition of redox reagents. With 0.1 mM ferricyanide, she found that $Y_3:Y_4$ increases, whereas with 0.1 mM 2,6-dichlorophenolindophenol (DCPIP)-ascorbate $Y_3:Y_4$ decreases. She interpreted these results as a change in the initial $S_1:S_0$ distribution and suggested a redox potential of $\sim +0.24$ V for the $S_1:S_0$ couple. However, based on equilibrium and rate constant calculations, Kok *et al.* (1975) estimated the redox potential for the $S_1:S_0$ couple to be $>+0.5$ V. Thus, weak redox reagents such as ferricyanide or DCPIP-ascorbate would not be expected to affect the S_n states directly. To explain the results of Bouges-Bocquet, Kok *et al.* proposed a model in which only O_2 is capable of direct oxidation of the intermediate. Accordingly, an equilibrium between S_0 and S_1 states is established by the oxidizing potential of O_2 and a pool of some endogenous reductant, R_k , that is,



The effect of redox reagents on the $Y_3:Y_4$ ratio would be to alter the pool size of R_k and thereby affect the $S_1:S_0$ equilibrium.

In disagreement with the preceding interpretation Greenbaum and Mauzerall (1976) and Greenbaum (1977) suggested that weak redox reagents can affect the S_n states directly. Under anaerobic conditions, they found the O_2 flash yield from *Chlorella* cells to be very low, with no oscillations. But upon addition of benzoquinone, normal oscillations could be obtained, indicating that the normal $S_1:S_0$ distribution was reestablished. In fact, the results showed a relatively high Y_2 suggesting that benzoquinone is a sufficiently strong oxidant to generate S_2 . The measured potential in the presence of benzoquinone was +0.34 V. However, to explain Greenbaum's results, Kok and Velthuys (1976) pointed out that due to cell respiration under anaerobic conditions the PQ pool is largely reduced. This would cause the recovery of Q^- to slow down (Diner and Mauzerall, 1973) and effectively increase the number of misses; thus, very little O_2 and no oscillations can be expected under these conditions. When benzoquinone is added, cell respiration is inhibited, the PQ pool becomes oxidized, and a normal O_2 flash yield pattern would be observed. Since S_2 was found to deactivate extremely slowly in the presence of benzoquinone, Y_2 will necessarily be high.

Other reductants have dramatic effects on the O_2 flash yield pattern.

Both NH_2OH at low concentrations ($\sim 50 \mu\text{M}$) (Bouges-Bocquet, 1973a) and H_2O_2 at high pH (~ 8.8) (Velthuys and Kok, 1978) cause a shift in the peak of the O_2 flash yield from the third flash to the fifth or sixth flash. Bouges-Bocquet interpreted her results as a photo-oxidation of bound NH_2OH in place of charge accumulation on the M intermediate. In contrast, Velthuys and Kok interpreted their results to indicate a reduction of the S_n states, i.e., S_2 to S_0 and S_1 to S_{-1} . The existence of an additional S_{-1} state may have important implications in anomalous first flash behavior in some experiments.

Since no O_2 is observed after the first flash and very little on the second flash, it was assumed by Kok *et al.* (1970) that the S_2 and S_3 states completely deactivate in the dark. Joliot *et al.* (1971) measured the deactivation rates and found that deactivation is faster in algae than in chloroplasts. In both algae and chloroplasts, they found the S_2 deactivation to closely approximate first-order kinetics, whereas S_3 deactivation did not. In contrast, in the measurements by Forbush *et al.* (1971) on chloroplasts all of the decay curves showed second-order kinetics.

Forbush *et al.* (1971) found a transient increase in S_2 at short dark times. From this they suggested that the deactivation process was a one-step mechanism, that is, $S_3 \rightarrow S_2$ and $S_2 \rightarrow S_1$. But based on $Y_3:Y_4$ ratios, Joliot *et al.* (1971) concluded that a two-step mechanism was also probably involved, that is, $S_3 \rightarrow S_1$ and $S_2 \rightarrow S_0$.

Lemasson and Barbieri (1971) reported that the S_3 decays at a faster rate in algae after preillumination with 650 nm light than with 700 nm light. Since 650 nm light tends to reduce an appreciable fraction of the PQ pool, these authors suggested that deactivation proceeds via a back reaction, which depends upon the reduction level of Q and the PQ pool. However, they could find no effect of preillumination on the S_2 deactivation. Alternatively, deactivation could be due to a direct reduction of M by some endogeneous electron donor. This endogenous donor could be cytochrome b_{559} , which is closely associated with the PSII reaction center (see Cramer and Crofts, Chapter 9, this volume).

Several reagents were discovered by Renger (1972) that speed up the rate of deactivation of the S_2 and S_3 states. Certain uncouplers such as CCCP and variously substituted thiophenes increase the rate of decay by as much as 100-fold. Renger called such reagents ADRY for the acceleration of the deactivation reactions of the water splitting enzyme system Y. He considered several mechanisms for ADRY behavior (Renger *et al.*, 1973), but concluded that the most likely possibility was one of an induced cyclic electron flow around PSII.

In contrast, it was found that NH_3 tends to stabilize the charge on the S_2 and S_3 states (Velthuys, 1975). Apparently, excitation of S_3 (NH_3)

yields S_4 (NH_3), but does not produce O_2 . Instead it undergoes a charge recombination reaction yielding back S_3 (NH_3). Also it was found that alkaline pH (> 8) tends to stabilize the S_2 state specifically (Briantais *et al.*, 1977). Furthermore, the S_2 state is the target of inactivation by Tris (Frasch and Chéniaie, 1980).

V. Chemistry

A. Proton Release

Kok's original model implied that two water molecules were oxidized in a concerted reaction, releasing 1 O_2 molecule and 4 H^+ simultaneously in the $S_3 \rightarrow S_4 \rightarrow S_0$ transition (Forbush *et al.*, 1971). The results from the first measurements of proton release in flashing light using a rapidly responding glass electrode were interpreted in terms of this mechanism (Fowler and Kok, 1974). However, the pH measurements were complicated by proton uptake by the PQ pool and the need to facilitate proton exchange across the membrane with uncouplers. Subsequent analysis of the proton flash yields indicated that protons are probably released in early S state transitions as well (Fowler, 1977). The proton release pattern which emerged was qualitatively 1,0,1,2 for the $S_0 \rightarrow S_1$, $S_1 \rightarrow S_2$, $S_2 \rightarrow S_3$ and $S_3 \rightarrow S_4 \rightarrow S_0$ transitions, respectively. However, Fowler pointed out that other minor proton release patterns may also contribute.

Neutral red and other dyes have been introduced as extremely sensitive and rapid indicators of flash-induced pH changes of the internal space of thylakoids (Aüsländer and Junge, 1975; Junge *et al.*, 1979). Using this method to measure the proton release associated with the O_2 -evolving reactions, Saphon and Crofts (1977) obtained results that agreed with those of Fowler (1977), whereas Junge and co-workers (Junge *et al.*, 1977; Junge and Aüsländer, 1978) did not. In the analysis made by Junge, a 0,1,1,2 proton release pattern was obtained. However, in thoroughly dark-adapted thylakoids, Förster *et al.* (1981) also obtained a 1,0,1,2 pattern. All results imply that protons are released prior to O_2 . One problem that has yet to be clarified is whether the pH changes arise directly and exclusively from the protons released from the breakdown of water itself or from some other localized proton pool in addition (e.g., an easily deprotonated proteinaceous component, which is connected to the O_2 -evolving apparatus). Baker *et al.* (1981) have suggested that the protons released by the O_2 -evolving system are initially sequestered from the intrathylakoid space, perhaps in a re-

stricted intramembrane region connected to the 8-kD component of the coupling factor. This added complication could certainly influence the measurements of pH changes in the intrathylakoid space. From a thermodynamic standpoint, a 0,1,1,2 pattern is perhaps more satisfying since the energy after one photoact is insufficient to extract the first electron from water (Renger, 1977, 1978). For further details, the reader is referred to Cramer and Crofts, Chapter 9; Ort and Melandri, Chapter 12; and Junge and Jackson, Chapter 13, this volume.

B. Manganese Requirement

1. HETEROGENOUS SITES

The importance of manganese in overall photosynthesis was recognized in early nutritional deficiency studies (Pirson, 1937), although it was found not to be required for the CO₂ fixing or PSI reactions (Kessler *et al.*, 1957; Spencer and Possingham, 1961; Hoch and Martin, 1963; Cheniae and Martin, 1966). However, treatments that block O₂ evolution but not electron flow from added electron donors to PSII [e.g. Tris washing (Yamashita and Butler, 1968), NH₂OH treatment (Cheniae and Martin, 1970), or temperature shock (Katoh and San Pietro, 1967; Homann, 1968; Kaniuga *et al.*, 1978)] cause a release of Mn from the membrane (Lozier *et al.*, 1971). These results led to the idea that Mn acts at or near the O₂-evolving site.

Using a Tris buffer extraction procedure, Cheniae and Martin (1970) quantitated the loss in O₂ activity with the loss of Mn. They found a linear decrease in O₂ evolution with the loss of about two-thirds of the total Mn. The membrane-bound Mn, which could not be removed by Tris extraction, did not appear to be involved with O₂ evolution or with the electron transport chain in general (Cheniae and Martin, 1970; Kimimura and Katoh, 1972). Cheniae (1970) thus proposed that there are at least two pools of membrane-bound Mn, a "loosely" bound pool associated with O₂ evolution and a "tightly" bound pool. The function of the tightly bound Mn remains unclear, although data indicates that it may be associated with the light-harvesting Chl *a/b* protein complex (Foyer and Hall, 1979; Khanna *et al.*, 1981b).

In addition to these two Mn pools, Mn may become bound at negatively charged sites on the surface of the membranes. In some references, this adventitious Mn is referred to as the "very loosely" bound pool. Apparently, it can be easily removed by washing the membranes with an EDTA solution or with a MgCl₂ solution at low pH (Khanna, 1980; Khanna *et al.*, 1981b).

The two-pool concept was confirmed using a NH_2OH treatment (Cheniae and Martin, 1971). However, the effectiveness of Mn removal by Tris extraction was found to be variable, although O_2 evolution was always completely inhibited (Itoh *et al.*, 1969; Selman *et al.*, 1973a). Using ESR methods to monitor free Mn(II), Blankenship and Sauer (1974) found that 60% of the total thylakoid Mn in their samples was released by Tris treatment. However, the released Mn could not be readily washed away from the membranes. Blankenship and Sauer (1974) concluded that the Mn is released to the inside of the thylakoid vesicle and that the actual loss from the vesicle requires the diffusion of Mn to the outside. In their sample, the diffusion was slow, $t_{1/2} \sim 2.5$ hours. Thus, the discrepancy in the earlier results was explained in terms of permeability properties of different sample preparations.

Using a combination of washes containing EDTA and Ca^{2+} ions, Yocum *et al.* (1981) were able to remove all of the adventitiously bound Mn in thylakoid membranes and maintain optimal O_2 -evolving rates. In such samples, they found a stoichiometry of 4 Mn atoms per 400 Chl molecules or per PSII unit. Upon further treatment of the sample to extract the remaining Mn, various amounts of Mn could be removed depending upon the procedure. After Tris washing in the light about 25% of the Mn could be removed. When Ca^{2+} ions were included during the Tris wash, about 50% of the Mn could be removed. And using NH_2OH plus Ca^{2+} ions as an extraction procedure, about 75% of the Mn could be removed. In all of these cases, O_2 evolution was completely inhibited. Yocum *et al.* (1981) thus proposed a model in which 4 Mn atoms are functionally associated with each O_2 -evolving center.

2. OXIDATION LEVEL

The multiple oxidation states of Mn makes it an attractive choice for a charge storage device. It is therefore highly desirable to have some method of monitoring Mn oxidation state changes in thylakoid membranes. One approach to this problem is to use proton NMR relaxation rate measurements. The magnetic relaxation of spin one-half nuclei, for instance, ^1H , is strongly influenced by electron nuclear dipolar interactions with bound paramagnetic ions, in particular Mn(II) (Dwek, 1973). The first measurements of the proton relaxation rates (PRR) of thylakoid suspensions were made by Wydrzynski *et al.* (1975). The rates were altered when the thylakoids were subjected to treatments known to affect membrane-bound Mn, e.g., Tris washing and NH_2OH treatment. Analysis of the field dispersion profiles of untreated thylakoid suspension yielded correlation times and relaxation parameters characteristic for Mn(II) paramagnetic interactions (Wydrzynski *et al.*, 1978). Addition

of the reductant tetraphenylboron enhanced the PRR, whereas addition of the oxidant potassium ferricyanide depressed the rates. However analysis of the field dispersion profiles in the presence of the redox reagents also yielded relaxation parameters characteristic of Mn(II). Thus, these results were taken to indicate that the PRR is sensitive to changes in the Mn(II) content of the membrane.

Gribova *et al.* (1976) confirmed the antagonistic effects of oxidants and reductants on the PRR in intact thylakoids. In addition, the antagonistic effects were also found in PSII preparations, but not in PSI or light-harvesting pigment protein preparations. These results suggest that the variable part of the enhancement in the PRR is associated with PSII. Khanna *et al.* (1981a) showed that the PRR also increases in the presence of NH_2OH or H_2O_2 ; both of these reagents are known to affect PSII and the O_2 -evolving mechanism specifically (Bouges-Bocquet, 1973a; Velthuys and Kok, 1978).

In contrast to the increase in the PRR by reductants, extraction of functional Mn by a Tris-acetone procedure (Yamashita and Tomita, 1974) consistently reduces the PRR (Wydrzynski *et al.*, 1978). Addition of reductants to Tris-acetone treated samples had no further effect on the rates. The PRR under these conditions were essentially field independent. Other procedures, which inhibit O_2 evolution but do not remove Mn from the sample, such as simple Tris washing, gave variable results, sometimes increasing and sometimes decreasing the PRR (Wydrzynski *et al.*, 1976a). The PRR are sensitive to all bound Mn ions, regardless of the binding site, as long as the neighboring protons can exchange rapidly with the solvent water protons. Thus, the variable results after Tris washing probably arise from a variable loss and/or rebinding of the released Mn. Only when released Mn is thoroughly washed out of the sample, as in the case of Tris-acetone treatment, will the PRR reflect the true contributions of the remaining tightly bound ions.

A selective displacement of Mn functional in O_2 evolution is obtained by high concentrations of magnesium salts (Chen and Wang, 1974). By using various concentrations of MgCl_2 to progressively inhibit O_2 evolution a parallel decrease in the PRR, O_2 activity, and Mn content of the membranes was found (Govindjee *et al.*, 1977, 1978). This was taken as further evidence for the relationship between the PRR and the Mn functional in O_2 evolution. However, in the manganese displacement procedure, the exact correlation between O_2 evolution and the loosely bound pool of Mn breaks down for freshly prepared samples, since a substantial O_2 activity remains even when two-thirds of the total Mn is removed. Chen and Wang (1974) attempted to explain this anomaly in

terms of a conformational change induced by magnesium. However, the parallel relationship between PRR, Mn content, and O_2 activity was also observed when Mn extraction is achieved by aging thylakoids for various times at 35°C (Khanna *et al.*, 1981a).

To further examine the relationship with the O_2 -evolving mechanism, the PRR was measured after flash illumination, since functional Mn might show period 4 phenomena. Indeed, the first measurements indicated that the spin-spin relaxation rate ($1/T_2$) at 26 MHz oscillates with a period of 4 in a series of brief light flashes (Wydrzynski *et al.*, 1976b; Govindjee *et al.*, 1977). However, attempts to reproduce the flash oscillations were often unsuccessful, the results being quite variable (R. Khanna, S. Rajan, T. Wydrzynski, H. S. Gutowsky and Govindjee, unpublished results). The reason for the failure to consistently reproduce these results at low field is still unclear.

In an entirely different interpretation of the low field PRR, Sharp and co-workers (Robinson *et al.*, 1980a, b; Sharp and Yocum, 1980) suggested that the Mn functional in O_2 evolution does not normally contribute to the observed rates, except under certain conditions such as in the presence of NH_2OH (Sharp and Yocum, 1981; Robinson *et al.*, 1981a). This interpretation is based largely on the observation that for samples that have been treated with EDTA or other chelators the PRR no longer show significant enhancement or field dispersion behavior characteristic of Mn(II), whereas the O_2 activity remains relatively unaffected. And changes in the PRR of the thylakoid suspensions in the light were interpreted as arising from the photo-oxidation of adventitiously bound Mn by superoxide ions generated by PSI (Robinson *et al.*, 1981b). However, Govindjee and Wydrzynski (1981) found that the presence of EDTA may reduce the low field PRR without removing Mn from the membrane. In agreement with Sharp and co-workers, the PRR was found to be low in the presence of EDTA, and there was no effect of added reductants. But when the samples were thoroughly washed with large volumes of buffer, the PRR increased relative to the values in the presence of EDTA, to a value the same as a control washed without EDTA, and the effects of added reductants were restored. The Mn content of samples treated with EDTA was not significantly different from that of samples simply washed with buffer medium only. Thus, EDTA appears to have an additional effect on the PRR, which is not related to its role as a chelator of adventitiously bound ions. Perhaps EDTA alters the exchange rate between the bound water and the solvent water protons, which causes a decrease in enhancement. Obviously, the experimental conditions strongly affect the PRR measurements.

Another method to monitor Mn is electron spin (paramagnetic) reso-

nance (ESR). At room temperature aqueous Mn(II) ions give rise to a characteristic six-line spectrum (Garrett and Morgan, 1966). Bound Mn on the other hand is usually believed to be ESR silent. In the last few years, however, several reports have appeared that describe ESR signals that arise from Mn bound in macromolecular complexes (e.g., see Meirovitch and Poupko, 1978). The appearance of the ESR signal in these cases, however, requires a unique coordination geometry.

For a suspension of thylakoid membranes active in O_2 evolution, a small but significant Mn ESR signal is often observed. Siderer *et al.* (1977) interpreted this signal as coming from a bound form of Mn. Light-induced changes in this signal in the presence of various inhibitors and electron acceptors indicated that the Mn undergoes photo-oxidation reactions associated with PSII. However, Theg and Sayre (1979) have suggested that the signal arises from free Mn in equilibrium with adventitiously bound Mn not associated with PSII and that the light-induced changes are associated with the ability of free Mn to act as a donor to PSII (Homann, 1972).

Upon inactivation of the O_2 mechanism by any number of treatments, including high concentrations of alkaline Tris buffer, NH_2OH , and gentle heating, the Mn ESR signal increases several fold (Lozier *et al.*, 1971). At least one-half of the increased signal is due to free Mn since this much of the signal is removed after sonication and washing (Blankenship and Sauer, 1974). In Tris-treated membranes, O_2 evolution can be restored upon further treatment with DCPIP-ascorbate in the light (Yamashita *et al.*, 1971) or reagents which destabilize S_2 and S_3 (Cheniae and Martin, 1978). In this case, the Mn ESR signal disappears suggesting that the Mn has been rebound to the membrane (Blankenship *et al.*, 1975). These results provide one of the strongest pieces of correlative evidence for the role of Mn in O_2 evolution.

The aqueous Mn ESR signal is characteristic of only the +2 oxidation state, higher oxidation states being unobservable under the conditions typically employed in room temperature ESR measurements. If Mn undergoes oxidation state changes in the light, then the Mn ESR signal observed upon inactivation of the O_2 -evolving mechanism should be variable after flash preillumination, providing that higher oxidation states of Mn do not simply reduce to Mn(II) upon release but rather undergo the usual disproportionation reactions (Cotton and Wilkinson, 1966). Using a brief temperature shock to rapidly release Mn functional in O_2 evolution using EDTA (10^{-4} M) washed samples. Wydrzynski and Sauer (1981) observed that the Mn ESR signal amplitude undergoes changes in response to PSII reactions prior to treatment. And after brief flashes of light, the Mn EPR signal was found to oscillate with period 4.

This is shown in Fig. 2. The maximum Mn ESR signal occurred in the dark and after the third and seventh flashes, whereas the minimum signal occurred after the second and fifth flashes. Assuming that the Mn released by heat treatment arises from the Mn functional in O_2 evolution, analysis of the oscillations in terms of the Kok model indicated that the oxidation level of the bound Mn (prior to release) increases on the $S_0 \rightarrow S_1$ and $S_1 \rightarrow S_2$ transitions, but decreases on the $S_2 \rightarrow S_3$ transition. A minimal model based on a Mn dimer was proposed for the O_2 -evolving intermediate and the oxidation character of the Mn was suggested to be: $S_0 = \text{Mn(II,II)}$; $S_1 = \text{Mn(II,III)}$; $S_2 = \text{Mn(III,III)}$; $S_2^* = \text{Mn(III,IV)}$; $S_3 = \text{Mn(II,III)}$; and $S_4 = \text{Mn(III,III)}$. The S_2^* state was proposed to be an additional, transitory state between S_2 and S_3 and may represent the S_2' state of Bouges-Bocquet (1973a). Although the ESR data analysis was most compatible with a two Mn complex per functional O_2 -evolving center, a four Mn complex can not be ruled out. Stoichiometrically there are four Mn atoms bound per O_2 -evolving center in intact thylakoid membranes and the loss of only 25% of the Mn inhibits O_2 evolution (Yocum *et al.*, 1981). Whether there is only one Mn dimer, two Mn dimers closely coupled together, or a Mn tetramer that is active in O_2 evolution still remains to be determined. The importance of the ESR

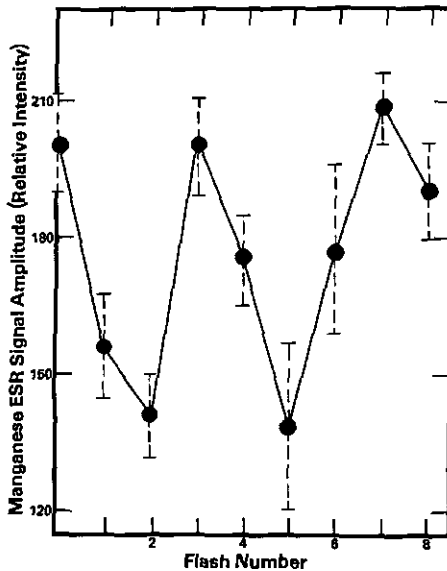

FIG. 2. Amplitudes of the manganese ESR signal for heat-treated (5 min at 55°C) spinach thylakoids following illumination with groups (from $n = 0$ to 8) of saturating light flashes. (Adapted from Fig. 4, Wydrzynski and Sauer, 1980.)

results is that Mn oxidation state changes are involved in O_2 evolution and that the oxidation level of the Mn increases on the first two S_n state transitions, but decreases on the third transition. A comparison of this model with the Mn model proposed by Renger (1977) and Govindjee *et al.* (1977) is presented by Sauer (1980).

Consistent with the preceding observations, results from X-ray absorption measurements of Mn in thylakoids indicate that the oxidation level of Mn in dark-adapted thylakoids is relatively low, but probably of mixed oxidation character (Kirby *et al.*, 1981a). With limitations, the X-ray absorption edge position of an element is linearly related to a quantity termed the coordination charge, which is a function of the formal oxidation state and local chemical environment of the absorbing atom (Cramer *et al.*, 1976; Kirby *et al.*, 1981a). In Fig. 3 the Mn edge inflection point energy for several Mn compounds is plotted as a function of the calculated coordination charge. Interestingly, the Mn edge position for dark-adapted thylakoids extrapolates to a coordination value, which is between Mn(II) and Mn(III) compounds. Analysis of the fine structure in the Mn absorption spectrum beyond the edge (i.e., EXAFS, Extended X-ray Absorption Fine Structure) indicates also that the average Mn atom of the loosely bound fraction in thylakoids has, as a near neighbor, another transition metal which could well be another Mn atom (Kirby, *et al.*, 1981b). In contrast, however, a low temperature multiline ESR signal having characteristics of a bi- or tetranuclear antiferromagnetically cou-

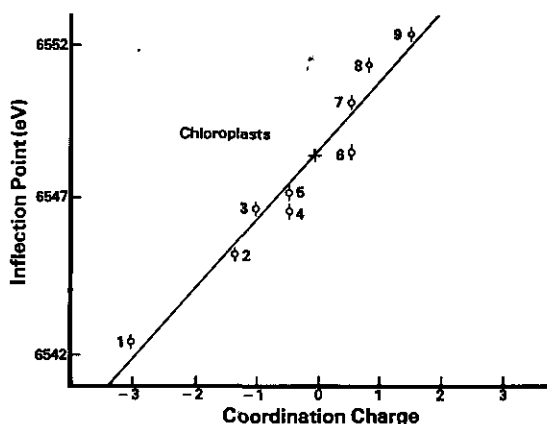

FIG. 3. Plot of the "coordination charge" against the measured manganese X-ray absorption-edge inflection point energies for a number of manganese compounds and spinach chloroplasts (denoted by +). (1) MnS; (2) Mn(II) thiophenylate; (3) MnCl₂; (4) Mn(II) oxalate; (5) Mn(II) acetylacetonate; (6) Mn(III) acetylacetonate; (7) Mn₂O₃; (8) Mn(IV,IV) phenanthroline; (9) MnO₂. (Adapted from Figure 2, Kirby *et al.*, 1981a.)

pled Mn complex containing Mn(III) and Mn(IV) was discovered in thylakoid membranes and was found to oscillate with period 4 after flash preillumination, indicating its relationship to the O₂-evolving system (Dismukes and Siderer, 1980, 1981). This signal and its relationship to the oxidizing side of PSII have been confirmed (Hansson and Andreasson, 1982). But despite the disagreement in the results, the data from magnetic resonance and X-ray absorption measurements are supportive of the concept that a Mn complex of mixed oxidation character is involved in the O₂-evolving process. The reader is referred to a recent review by Ames (1982) on the role of Mn in O₂ evolution.

C. Proteinaceous Components

The involvement of proteinaceous components in PSII and the O₂-evolving reactions has been implicated in many studies using protein modifiers (Selman *et al.*, 1973b; Giaquinta *et al.*, 1974), mutants (Chua and Bennoun, 1975; Delepelaire and Chua, 1978; Wessels and Borchert, 1978), immunological methods (Radunz and Schmid, 1973; Zilinskas and Govindjee, 1974; Schmid *et al.*, 1978), fluorescence probe measurements (Kobayashi *et al.*, 1978), differential scanning calorimetry (Cramer *et al.*, 1981), and UV absorption kinetic measurements (Pulles *et al.*, 1976; Mathis and Haveman, 1977; Velthuys, 1981). However, attempts to isolate a specific O₂-evolving protein are largely unsuccessful, primarily because it is extremely difficult to demonstrate restoration of O₂ activity (for unsubstantiated exceptions, see Huzisige *et al.*, 1968; Tel-Or and Avron, 1975). Instead most efforts have been concentrated on the isolation and characterization of PSII membrane fractions and/or Mn containing proteins (Anderson and Boardman, 1966; Cheniae and Martin, 1966; Huzisige *et al.*, 1969; Vernon and Shaw, 1969; Wessels *et al.*, 1973; Lagoutte and Duranton, 1975; Henriques and Park, 1976; Haldsworth and Arshad, 1977; Van Kamela and Wegmann, 1977; Satoh, 1979; Stewart and Bendall, 1979; Diner and Wollman, 1980; Stewart, 1980; Berthold *et al.*, 1981; England and Evans, 1981; Evans and Pullin, 1981; Nugent *et al.*, 1981; Stewart and Bendall, 1981; Yamamoto *et al.*, 1981; Henry and Moller, 1982).

Spector and Winget (1980) and Winget and Spector (1981), however, have reported on the isolation of a 65 kD protein containing Mn from dark-adapted thylakoids using a mild cholate extraction procedure. This protein, when added to protein-depleted membranes in liposome vesicles, was found to restore up to 85% of the original O₂-evolving capacity. The reconstituted preparation, prepared and supplied by M. Spector, also showed normal O₂ yield pattern in a series of light flashes as well as

the variable yield of the Chl *a* fluorescence (Govindjee *et al.*, 1980). Unfortunately, additional attempts to isolate and reconstitute this protein to restore O₂ activity were unsuccessful (Govindjee, personal communication; G. D. Winget, personal communication).

In contrast, Metz and Bishop (1980) and Metz *et al.* (1980) isolated low fluorescence mutants of *Scenedesmus*, which were deficient in O₂ evolution and had an altered 34-kD protein. Since the Mn content of the mutants was low, these authors suggested that the 34-kD polypeptide is the Mn binding protein associated with O₂ evolution. Another 32–34-kD polypeptide was isolated from spinach by Kuwahara and Murata (1979), but this is unrelated to the O₂-protein.

These early reports of proteins associated with O₂ evolution led to a flurry of investigations, which were reported at the Fifth International Congress on Photosynthesis, Halkidiki, Greece, in September, 1980. Nakatani and Barber (1981) using a procedure similar to the one used by Spector and Winget (1980) obtained a 58-kD protein that could partially restore O₂-evolving activity in liposome vesicles. However, the Mn content of the protein preparation was insufficient to account for a stoichiometric binding of Mn to the protein. The protein, however, did contain heme iron. But it is still not yet clear if this protein functions at the O₂-evolving site directly. It may be an extra-chloroplastic catalase enzyme. Sayre and Cheniae (1982), on the other hand, could remove a 65-kD protein from thylakoids using an asolectin–cholate extraction procedure. But the loss of Mn associated with the removal of the protein was again not stoichiometric with the loosely bound fraction of the Mn in the original membranes; moreover, no significant restoration of O₂-evolving activity in extracted membranes was achieved. However, Sayre and Cheniae (1982) did succeed in isolating a mixture of smaller polypeptides that did not contain Mn but could restore some O₂ activity. Similarly, Åkerlund (1981) was able to obtain an O₂-restoring protein fraction free of Mn from inside-out thylakoid vesicle preparations (Andersson *et al.*, 1977; Anderson and Åkerlund, 1978) after high salt washes. Most likely, a number of proteinaceous components are involved in the O₂ side of PSII, and one or more may or may not be associated with Mn (also see Andersson and Arnesson, 1981). However, research in the next few years should lead to a better understanding of the role of proteins in the O₂-evolving mechanism.

D. Other Cofactors

Next to that of Mn, chloride (Cl⁻) as a necessary cofactor in O₂ evolution has been the most thoroughly studied. Warburg and Lüttgens

(1944) first showed that Cl^- stimulated the Hill reaction. Bové *et al.* (1963) demonstrated the requirement for Cl^- ions by PSII reactions, whereas Izawa *et al.* (1969) and Kelley and Izawa (1978) localized the Cl^- site to the electron donor side of PSII and suggested that it is required in one of the O_2 -evolving steps. Luminescence measurements of the PSII back reactions in Cl^- sufficient and Cl^- depleted thylakoids also support the role of Cl^- on the oxidizing side of PSII (Muallem and Lainé-Bözörmenyi, 1981) as do studies on thylakoids isolated from halophytic plants (Critchley, 1982). However, the Cl^- effect on O_2 evolution could not always be demonstrated (Sato *et al.*, 1974; Terry, 1977). The discrepancies in the results were explained in terms of incomplete removal of Cl^- during sample preparation. It was found that conditions such as age of the sample, pH, and the presence of uncouplers and EDTA were important in the removal of Cl^- (Kelley and Izawa, 1978; Theg and Homann, 1982).

The role of Cl^- in O_2 evolution is completely unknown. But one may speculate that Cl^- is a ligand to the Mn in the O_2 -evolving apparatus (Goldfelf, *et al.*, 1979) and helps stabilize its higher oxidation states (Wydrzynski and Sauer, 1980). In this context, it is interesting to note that the presence of Cl^- slows down inhibition of O_2 evolution by NH_2OH (Kelley and Izawa, 1978). NH_2OH reduces bound Mn to Mn(II) (Khanna *et al.*, 1981b) and eventually causes its release from the membrane (Cheniae and Martin, 1971). Also, it was found that exogenous Mn can inhibit O_2 evolution, but only in Cl^- deficient thylakoid preparations (Muallem and Izawa, 1980). These results suggest a direct interaction between Mn and Cl^- ions, but it becomes essential to have a method to monitor Cl^- *in vivo* to gain more detailed information.

One approach to study Cl^- in biological systems is to use NMR methods (Ward, 1975). The $^{35}\text{Cl}^-$ nucleus is NMR active, and its relaxation rate may be expected to reflect paramagnetic interactions, much like the PRR (Section V,B,2). However, preliminary measurements showed no large enhancement in the Cl^- relaxation rates of thylakoid samples (T. Wydrzynski and R. Ward, 1979, unpublished results). The lack of significant enhancement in the rates may be because Cl^- does not interact directly with the thylakoid Mn or because the Cl^- relaxation rate is exchange limited. However, Critchley *et al.* (1982) have obtained an almost parallel relationship between high-field ^{35}Cl NMR line broadening and O_2 evolution rates when they plotted these parameters for mangrove chloroplasts as a function of pH.

Alternatively, fluorine (^{19}F) can be used as a probe for paramagnetic ions in biological systems (Marwedel *et al.*, 1975). Due to a smaller ionic radius, fluoride ions bind stronger than chloride ions, but they do not

support O_2 evolution. The ^{19}F relaxation rate of thylakoids depleted of Cl^- and to which NaF was added was considerably faster than the buffer control (Govindjee *et al.*, 1978). The relaxation rate could be increased by adding tetraphenylboron or decreased by Tris-acetone treatment of the membranes. This behavior in ^{19}F relaxation parallels the behavior in the PRR, indicating that ^{19}F relaxation was also probing bound Mn. Unfortunately, F^- ions are a very poor substitute for Cl^- ions in O_2 evolution (Kelley and Izawa, 1978). Thus, the role of Cl^- , or another anion, in O_2 evolution still remains unclear. For a proposed model on the reversible binding of Cl^- to active sites in thylakoid membranes based on NMR measurements, see Baianu *et al.* (1982). The use of NMR methods, however, will become more valuable as purified O_2 -evolving components are isolated.

In the last few years, calcium ions have become recognized as a necessary cofactor for O_2 evolution (Piccioni and Mauzerall, 1976, 1978a,b; Barr *et al.*, 1982). Depletion of Ca^{2+} ions in preparations of the cyanobacterium *Phormidium luridum* resulted in a block on the O_2 -evolving side of PSII. But whether Ca^{2+} ions interact directly in the O_2 evolving reactions or serve some secondary, perhaps structural, function has yet to be determined. There is also a suggestion that quinone-type intermediates may be involved as well (see, e.g., Sadewasser and Dille, 1978), perhaps in a close association with the water splitting complex (Gol'dfel'd *et al.*, 1980). Improved isolation and characterization of proteinaceous components involved in the O_2 -evolving reactions will greatly facilitate the understanding of the role of these cofactors.

For a discussion of the artificial chemical systems dealing with the water-splitting process, the reader is referred to a review by Harriman and Barber (1979).

Acknowledgments

I am extremely grateful to Bruno Velthuys and Gernot Renger for reading the manuscript and suggesting many valuable improvements. I would also like to acknowledge financial support during the early stages of this work from National Science Foundation Grants to Govindjee, Department of Physiology and Biophysics (PCM 11657) and to H. S. Gutowsky, Department of Chemistry (CHE 04585 and PCM 11148), University of Illinois, Urbana, Illinois.

REFERENCES

- Åkerlund, H.-E. (1981). *Proc. Int. Congr. Photosynth.*, 5th, 1980, II, pp. 465-472.
Allen, F., and Franck, J. (1955). *Arch. Biochem. Biophys.* 58, 124-143.

- Amesz, J. (1982). *Biochim. Biophys. Acta Rev. (Bioenergetics)* (in press).
- Anderson, J. M., and Boardman, N. K. (1966). *Biochim. Biophys. Acta* **112**, 403–421.
- Andersson, B., and Åkerlund, H.-E. (1978). *Biochim. Biophys. Acta* **503**, 462–472.
- Andersson, B., Åkerlund, H.-E., and Albertsson, P.-Å. (1977). *FEBS Lett.* **77**, 141–145.
- Andreasson, L.-E., and Arnesson, T. (1981). *FEBS Lett.* **125**, 65–68.
- Arnason, T., and Sinclair, J. (1976a). *Biochim. Biophys. Acta* **430**, 517–523.
- Arnason, T., and Sinclair, J. (1976b). *Biochim. Biophys. Acta* **449**, 581–586.
- Ausländer, W., and Junge, W. (1975). *FEBS Lett.* **59**, 310–315.
- Babcock, G. T., and Sauer, K. (1973a). *Biochim. Biophys. Acta* **325**, 483–503.
- Babcock, G. T., and Sauer, K. (1973b). *Biochim. Biophys. Acta* **325**, 504–519.
- Baianu, I. C., Critchley, C., Gutowsky, H. S., and Govindjee (1982). *Proc. Natl. Acad. Sci. U.S.A.* (to be submitted).
- Baker, G. M., Bhatnager, D., and Dilley, R. A. (1981). *Biochem.* **20**, 2307–2315.
- Barr, R., Troxel, K. S., and Crane, S. L. (1982). *Biochem. Biophys. Res. Comm.* **104**, 1182–1188.
- Berthelot, M. (1864). "Leçons sur les méthodes générales de synthèse en chimie organique." Gauthier-Villars, Paris.
- Berthold, D. A., Babcock, G. T., and Yocum, C. F. (1981). *FEBS Lett.* **134**, 231–234.
- Blankenship, R. E., and Sauer, K. (1974). *Biochim. Biophys. Acta* **357**, 252–266.
- Blankenship, R. E., Babcock, G. T., and Sauer, K. (1975). *Biochim. Biophys. Acta* **387**, 165–175.
- Bouges-Bocquet, B. (1973a). *Biochim. Biophys. Acta* **292**, 772–785.
- Bouges-Bocquet, B. (1973b). *Biochim. Biophys. Acta* **314**, 250–256.
- Bouges-Bocquet, B. (1980). *Biochim. Biophys. Acta* **594**, 85–104.
- Bové, J. M., Bové, C., Whately, F. R., and Arnon, D. I. (1963). *Z. Naturforsch., B: Anorg. Chem., Org. Chem., Biochem., Biophys., Biol.* **18B**, 683–688.
- Bowes, J. M., Crofts, A. R., and Itoh, S. (1979). *Biochim. Biophys. Acta* **547**, 336–346.
- Briantais, J.-M., Vernotte, C., Lavergne, J., and Arntzen, C. J. (1977). *Biochim. Biophys. Acta* **461**, 61–74.
- Chen, K.-Y., and Wang, J. H. (1974). *Bioinorg. Chem.* **3**, 339–352.
- Cheniae, G. M. (1970). *Annu. Rev. Plant Physiol.* **21**, 467–498.
- Cheniae, G. M., and Martin, I. F. (1966). *Brookhaven Symp. Biol.* **19**, 409–417.
- Cheniae, G. M., and Martin, I. F. (1970). *Biochim. Biophys. Acta* **197**, 219–239.
- Cheniae, G. M., and Martin, I. F. (1971). *Plant Physiol.* **47**, 568–575.
- Cheniae, G. M., and Martin, I. F. (1978). *Biochim. Biophys. Acta* **502**, 321–344.
- Chua, N., and Bennoun, P. (1975). *Proc. Natl. Acad. Sci. U.S.A.* **72**, 2175–2179.
- Cotton, F. A., and Wilkinson, C. (1966). "Advanced Inorganic Chemistry, A Comprehensive Text," 2nd ed., pp. 834–947. Wiley (Interscience), New York.
- Cramer, S. P., Eccles, T. K., Kutzlur, F., Hodgson, K. O., and Mortenson, L. E. (1976). *J. Am. Chem. Soc.* **98**, 1287–1288.
- Cramer, W. A., Whitmarsh, J., and Low, P. S. (1981). *Biochem.* **20**, 157–162.
- Critchley, C. (1982). *Nature* (in press).
- Critchley, C., Baianu, I. C., Govindjee, and Gutowsky, H. S. (1982). *Biochim. Biophys. Acta* (in press).
- Deleplaire, P., and Chua, N. (1978). *Proc. Natl. Acad. Sci. U.S.A.* **76**, 111–115.
- Delrieu, M.-J. (1974). *Photochem. Photobiol.* **20**, 441–454.
- Diner, B. (1974). *Biochim. Biophys. Acta* **368**, 371–385.
- Diner, B. (1977). In "Photosynthesis '77" (D. O. Hall, J. Coombs, and T. W. Goodwin, eds.), pp. 359–372. Biochemical Society, London.
- Diner, B., and Joliot, P. (1977). *Encycl. Plant Physiol., New Ser.* **5**, 187–205.

- Diner, B., and Mauzerall, D. (1973). *Biochim. Biophys. Acta* **305**, 353-363.
- Diner, B., and Wollman, F.-A. (1980). *Eur. J. Biochem.* **110**, 521-526.
- Dismukes, G. C., and Siderer, Y. (1980). *FEBS Lett.* **121**, 78-80.
- Dismukes, G. C., and Siderer, Y. (1981). *Proc. Natl. Acad. Sci. U.S.A.* **78**, 274-277.
- Doschek, W. W., and Kok, B. (1972). *Biophys. J.* **12**, 832-838.
- Duysens, L. N. M. (1958). *Brookhaven Symp. Biol.* **11**, 10-25.
- Dwek, R. A. (1973). "Nuclear Magnetic Resonance (N.M.R.) in Biochemistry: Application to Enzyme Systems." Oxford Univ. Press (Clarendon), London and New York.
- Eckert, H. J., and Renger, G. (1980). *Photochem. Photobiol.* **31**, 501-511.
- Emerson, R., and Arnold, W. (1932). *J. Gen. Physiol.* **16**, 191-205.
- England, R. R., and Evans, E. H. (1981). *FEBS Lett.* **134**, 175-177.
- Etienne, A.-L. (1968). *Biochim. Biophys. Acta* **153**, 895-897.
- Evans, E. H., and Pullin, C. A. (1981). *Biochem. J.* **196**, 489-493.
- Forbush, B., Kok, B., and McGloin, M. (1971). *Photochem. Photobiol.* **14**, 307-321.
- Förster, V., Hong, Y.-Q., and Junge, W. (1981). *Biochim. Biophys. Acta* **638**, 141-152.
- Fowler, C. F. (1977). *Biochim. Biophys. Acta* **462**, 414-421.
- Fowler, C. F., and Kok, B. (1974). *Biochim. Biophys. Acta* **357**, 308-318.
- Foyer, C. H., and Hall, D. O. (1979). *FEBS Lett.* **101**, 324, 328.
- Franck, J., and Herzfeld, K. F. (1937). *J. Phys. Chem.* **41**, 97-107.
- Frasch, W., and Cheniae, G. (1980). *Plant Physiol.* **65**, 735-745.
- Gaffron, H., and Wohl, K. (1936). *Naturwissenschaften* **24**, 81-107.
- Garrett, B. B., and Morgan, L. O. (1966). *J. Chem. Phys.* **44**, 890-897.
- Giaquinta, R. T., Dilley, R. A., Selman, B. R., and Anderson, B. H. (1974). *Arch. Biochem. Biophys.* **162**, 200-209.
- Gläser, M., Wolff, C. Buchwald, H., and Witt, H. (1974). *FEBS Lett.* **42**, 81-85.
- Gläser, M., Wolff, C., and Renger, G. (1976). *Z. Naturforsch. C: Biosci.* **31C**, 712-721.
- Gol'dfel'd, M. G., Blyumenfel'd, L. A., Dmitrovskii, L. G., and Mikoyan, V. B. (1980). *Mol. Biol. (Kiev)* **14**, 804-813.
- Gol'dfel'd, M., Khailova, I. I., and Vanin, A. F. (1979). *Biofizika* **24**, 550-551.
- Govindjee (1980). *Plant Biochem. J. S. M. Sircar Memorial Volume*, pp. 7-30.
- Govindjee, ed. (1982). "Photosynthesis: Development, Carbon Metabolism, and Plant Productivity," Vol. II. Academic Press, New York.
- Govindjee, and Jursinic, P. J. (1979). *Photochem. Photobiol. Rev.* **4**, 125-205.
- Govindjee, and van Rensen, J. J. S. (1978). *Biochim. Biophys. Acta* **505**, 183-213.
- Govindjee, and Wydrzynski, T. (1981). *Proc. Int. Congr. Photosynth., 5th, 1980* pp. 293-305.
- Govindjee, Wydrzynski, T., and Marks, S. B. (1977). In "Bioenergetics of Membranes" (L. Packer and G. Papageorgiou, eds.), pp. 305-316. Elsevier-North-Holland, Amsterdam.
- Govindjee, Wydrzynski, T., and Marks, S. B. (1978). In "Photosynthetic Oxygen Evolution" (H. Metzner, ed.), pp. 321-344. Academic Press, New York.
- Govindjee, Fork, D. C., Wydrzynski, T., Spector, M., and Winget, G. D. (1980). *Photochem. Photobiophys.* **1**, 347-351.
- Greenbaum, E. (1977). *Photochem. Photobiol.* **25**, 293-298.
- Greenbaum, E., and Mauzerall, D. C. (1976). *Photochem. Photobiol.* **23**, 369-372.
- Gribova, Z. P., Zakharova, N. I., and Murza, L. I. (1976). *Mol. Biol. (Kiev)* **12**, 157-164.
- Haldsworth, E. S., and Arshad, J. H. (1977). *Arch. Biochem. Biophys.* **183**, 361-373.
- Hansson, Ö., and Andréasson, L.-E. (1982). *Biochim. Biophys. Acta* **679**, 261-268.
- Harriman, A., and Barber, J. (1979). In "Photosynthesis in Relation to Model Systems" (J. Barber, ed.), pp. 243-280. Elsevier, Amsterdam.
- Henriques, F., and Park, R. B. (1976). *Biochim. Biophys. Acta* **430**, 312-320.
- Henry, L. E., and Moller, B. L. (1982). *Carlsburg Commun.* **46**, 226-242.
- Hill, R., and Scarisbrick, R. (1940). *Nature (London)* **146**, 61-62.

- Hoare, J. P. (1968). "The Electrochemistry of Oxygen." Wiley (Interscience), New York.
- Hoch, G., and Martin, I. F. (1963). *Arch. Biochem. Biophys.* **102**, 430-438.
- Homann, P. (1968). *Biochem. Biophys. Res. Commun.* **33**, 225-234.
- Homann, P. (1972). *Biochim. Biophys. Acta* **256**, 336-344.
- Huzisige, M., Isimoto, M., and Inoue, M. (1968). In "Comparative Biochemistry and Biophysics of Photosynthesis" (K. Shibata, A. Takamiya, A. T. Jagendorf, and R. C. Fuller, eds.), pp. 170-175. Univ. of Tokyo Press, Tokyo.
- Huzusize, H., Usiyama, H., Kikuti, T., and Azi, T. (1969). *Plant Cell Physiol.* **10**, 441-455.
- Inoue, I. (1981). *Biochem. Biophys. Acta* **634**, 309-320.
- Inoue, Y., and Shibata, K. (1978). *FEBS Lett.* **85**, 193-197.
- Inoue, Y., Furuta, S., Oku, T., and Shibata, K. (1976). *Biochim. Biophys. Acta* **449**, 357-367.
- Itoh, M., Yamashita, K., Nishi, T., Konishi, K., and Shibata, K. (1969). *Biochim. Biophys. Acta* **180**, 509-519.
- Izawa, S., Heath, R. L., and Hind, G. (1969). *Biochim. Biophys. Acta* **180**, 388-398.
- Joliot, P. (1965). *Biochim. Biophys. Acta* **102**, 116-134.
- Joliot, P. (1968). *Photochem. Photobiol.* **8**, 451-463.
- Joliot, P., and Joliot, A. (1968). *Biochim. Biophys. Acta* **153**, 625-634.
- Joliot, P., and Joliot, A. (1977). *Biochim. Biophys. Acta* **462**, 559-574.
- Joliot, P., and Joliot, A. (1981). *Biochim. Biophys. Acta* **638**, 132-140.
- Joliot, P., and Kok, B. (1975). In "Bioenergetics of Photosynthesis" (Govindjee, ed.), pp. 387-412. Academic Press, New York.
- Joliot, P., Hoffnung, M., and Chabaud, R. (1966). *J. Chim. Phys.* **63**, 1423-1441.
- Joliot, P., Barbieri, G., and Chabaud, R. (1969). *Photochem. Photobiol.* **10**, 309-329.
- Joliot, P., Joliot, A., Bouges, B., and Barbieri, G. (1971). *Photochem. Photobiol.* **14**, 287-305.
- Joliot, P., Bennoun, P., and Joliot, A. (1973). *Biochim. Biophys. Acta* **305**, 317-328.
- Junge, W., and Ausländer, W. (1978). In "Photosynthetic Oxygen Evolution" (H. Metzner, ed.), pp. 213-228. Academic Press, New York.
- Junge, W., Renger, G., and Ausländer, W. (1977). *FEBS Lett.* **79**, 155-159.
- Junge, W., Ausländer, W., McCreer, A. J., and Runge, J. (1979). *Biochim. Biophys. Acta* **546**, 121-141.
- Jursinic, P. (1979). *Arch. Biochem. Biophys.* **196**, 484-492.
- Jursinic, P. (1981). *Biochim. Biophys. Acta* **635**, 38-52.
- Kaniuga, Z., Zabek, J., and Sochanowicz, B. (1978). *Planta* **144**, 49-56.
- Katoh, S., and San Pietro, A. (1967). *Arch. Biochem. Biophys.* **122**, 144-152.
- Kelley, P. M., and Izawa, S. (1978). *Biochim. Biophys. Acta* **502**, 198-210.
- Kessler, E., Arthur, W., and Brugger, J. E. (1957). *Arch. Biochem. Biophys.* **71**, 326-335.
- Khanna, R., Rajan, S., Govindjee, and Gutowsky, H. S. (1981a). *Proc. Int. Congr. Photosynth.*, **5th, 1980** pp. 307-316.
- Khanna, R., Rajan, S., Steinbeck, K. E., Bose, S., Govindjee, and Gutowsky, H. S. (1981b). *Isr. J. Chem.* **21**, 291-295.
- Kimimura, M., and Katoh, S. (1972). *Plant Cell Physiol.* **13**, 287-296.
- Kirby, J. A., Goodin, D. B., Wydrzynski, T., Robertson, A. S., and Klein, M. P. (1981a). *J. Am. Chem. Soc.* **103**, 5537-5542.
- Kirby, J. A., Robertson, A. S., Smith, J. P., Thompson, A. C., Cooper, S. R., and Klein, M. P. (1981b). *J. Am. Chem. Soc.* **103**, 5529-5537.
- Klimov, V. V., Allakherdiev, S. I., and Pascherko, V. Z. (1978). *Dokl. Akad. Nauk SSSR* **242**, 1204-1207.
- Knox, R. S. (1969). *Biophys. J.* **9**, 1351-1362.
- Kobayashi, Y., Inoue, Y., and Shibata, K. (1978). In "Photosynthetic Oxygen Evolution" (H. Metzner, ed.), pp. 157-170. Academic Press, New York.
- Kok, B. (1956). *Biochim. Biophys. Acta* **21**, 245-258.

- Kok, B., and Cheniae, G. M. (1966). *Curr. Top. Bioenerg.* **1**, 1-47.
- Kok, B., and Velthuys, B. (1976). *Proc. Int. Congr. Photobiol. 7th, 1976 Book Abstracts*, p. S-12.
- Kok, B., Forbush, B., and McGloin, M. (1970). *Photochem. Photobiol.* **11**, 457-475.
- Kok, B., Radmer, R., and Fowler, C. F. (1975). *Proc. Int. Congr. Photosynth., 3rd, 1974 pp.* 485-496.
- Kuwahara, T., and Murata, N. (1979). *Biochim. Biophys. Acta* **581**, 228-236.
- Lagoutte, B., and Duraton, J. (1975). *FEBS Lett.* **51**, 21-24.
- Lavorel, J. (1976a). *J. Theor. Biol.* **57**, 171-185.
- Lavorel, J. (1976b). *FEBS Lett.* **66**, 164-167.
- Lavorel, J., and Lemasson, C. (1976). *Biochim. Biophys. Acta* **430**, 501-516.
- Lemasson, C., and Barbieri, G. (1971). *Biochim. Biophys. Acta* **245**, 386-397.
- Lozier, R., Baginsky, M., and Butler, W. L. (1971). *Photochem. Photobiol.* **14**, 323-328.
- Maison-Peteri, B. (1980). *Biochim. Biophys. Acta* **592**, 338-348.
- Maison-Peteri, B. (1981). *Proc. Int. Congr. Photosynth., 5th, 1980 Book Abstracts*, p. 359.
- Mar, T., and Govindjee (1971). *J. Theor. Biol.* **36**, 427-466.
- Marwedel, B. J., Kurland, R. J., Kosman, D. J., and Ettinger, M. J. (1975). *Biochem. Biophys. Res. Commun.* **63**, 773-779.
- Mathis, P., and Havemen, J. (1977). *Biochim. Biophys. Acta* **451**, 167-181.
- Meirovitch, E., and Poupko, R. (1978). *J. Phys. Chem.* **82**, 1920-1925.
- Metz, J. G., and Bishop, N. I. (1980). *Biochem. Biophys. Res. Commun.* **94**, 560-566.
- Metz, J. G., Wong, J., and Bishop, N. I. (1980). *FEBS Lett.* **114**, 61-66.
- Metzner, H. (1975). *J. Theor. Biol.* **51**, 201-231.
- Metzner, H., Fischer, K., and Balzar, O. (1979). *Biochim. Biophys. Acta* **548**, 287-295.
- Muallem, A., and Izawa, S. (1980). *FEBS Lett.* **115**, 49-53.
- Muallem, A., and Lainé-Böszörményi, M. (1981). *Photobiochem. Photobiophys.* **2**, 337-345.
- Nakatani, H. Y., and Barber, J., (1981). *Photobiochem. Photobiophys.* **2**, 69-78.
- Nugent, J. H. A., Stewart, A. C., and Evans, M. C. W. (1981). *Biochim. Biophys. Acta*, **635**, 488-497.
- Ohta, T. (1979). In "Solar-Hydrogen Energy Systems" (T. Ohta, ed.), pp. 25-33. Pergamon, Oxford.
- Parson, W. W. (1978). *Photochem. Photobiol.* **28**, 389-393.
- Piccioni, R. G., and Mauzerall, D. C. (1976). *Biochim. Biophys. Acta* **423**, 605-609.
- Piccioni, R. G., and Mauzerall, D. C. (1978a). *Biochim. Biophys. Acta* **504**, 394-397. ?
- Piccioni, R. G., and Mauzerall, D. C. (1978b). *Biochim. Biophys. Acta* **504**, 398-405.
- Pirson, A. (1937). *Z. Bot.* **31**, 193-267.
- Priesdy, J. (1776). "Experiments and Observations on Different Kinds of Air" Vol. 1. J. Johnson, London.
- Pulles, M. P. J., Van Gorkom, H. J., and Willemsen, J. G. (1976). *Biochim. Biophys. Acta* **449**, 536-540.
- Rabinowitch, E. (1945). "Photosynthesis and Related Topics" Vol. I. Wiley (Interscience), New York.
- Radmer, R., and Cheniae, G. M. (1977). *Top. Photosynth.* **2**, 303-348.
- Radmer, R., and Kok, B. (1975). *Annu. Rev. Biochem.* **44**, 409-433.
- Radmer, R., and Ollinger, O. (1980). *FEBS Lett.* **110**, 57-61.
- Radunz, A., and Schmid, G. H. (1973). *Z. Naturforsch., C: Biosci.* **28C**, 36-44.
- Renger, G. (1970). *Z. Naturforsch. B: Anorg. Chem., Org. Chem., Biochem., Biophys., Biol.* **25b**, 966-971.
- Renger, G. (1972). *Physiol. Veg.* **10**, 329-345.

- Renger, G. (1977). *FEBS Lett.* **81**, 223–228.
- Renger, G. (1978). In "Photosynthetic Oxygen Evolution" (H. Metzner, ed.), pp. 229–248. Academic Press, New York.
- Renger, G., and Eckert, H. J. (1981). *J. Bioenerg. Bioelectrochem.* (in press).
- Renger, G., Bouges-Bocquet, B., and Deslome, R. (1973). *Biochim. Biophys. Acta* **292**, 796–802.
- Robinson, H. H., Sharp, R. R., and Yocum, C. F. (1980a). *Biochem. Biophys. Res. Commun.* **93**, 755–761.
- Robinson, H. H., Sharp, R. R., and Yocum, C. F. (1980b). *Biochim. Biophys. Acta* **593**, 414–426.
- Robinson, H. H., Sharp, R. R., and Yocum, C. F. (1981a). *Biochim. Biophys. Acta* **636**, 144–152.
- Robinson, H. H., Sharp, R. R., and Yocum, C. F. (1981b). *Arch. Biochem. Biophys.* **207**, 1–8.
- Ross, R. T., and Calvin, M. (1967). *Biophys. J.* **7**, 595–614.
- Ruben, S., Randall, M., Kamen, M., and Hyde, J. L. (1941). *J. Am. Chem. Soc.* **63**, 877–879.
- Sadewasser, D. A., and Dilley, R. A. (1978). *Biochim. Biophys. Acta* **501**, 208–216.
- Saphon, S., and Crofts, A. R. (1977). *Z. Naturforsch., C: Biosci.* **32C**, 617–626.
- Satoh, K. (1979). *Biochim. Biophys. Acta* **546**, 84–92.
- Satoh, K., Takamiya, A., and Katoh, S. (1974). *Plant Cell Physiol.* **15**, 727–731.
- Sauer, K. (1980). *Acc. Chem. Res.* **13**, 249–256.
- Sayre, R. T., and Cheniae, G. M. (1982). *Plant Physiol.* **69**, 1084–1095.
- Schmid, G. H., Radunz, A., Koenig, F., and Menke, W. (1978). In "Photosynthetic Oxygen Evolution" (H. Metzner, ed.), pp. 91–104. Academic Press, New York.
- Selman, B. R., Bannister, T. T., and Dilley, R. A. (1973a). *Biochim. Biophys. Acta* **292**, 566–581.
- Selman, B. R., Bannister, T. T., and Dilley, R. A. (1973b). *Biochim. Biophys. Acta* **253**, 428–436.
- Sharp, R. R., and Yocum, C. F. (1980). *Biochim. Biophys. Acta* **592**, 185–195.
- Sharp, R. R., and Yocum, C. F. (1981). *Biochim. Biophys. Acta* **635**, 90–104.
- Siderer, Y., Malkin, S., Poupko, R., and Luz, Z. (1977). *Arch. Biochem. Biophys.* **179**, 174–182.
- Sinclair, J., and Arnason, T. (1974). *Biochim. Biophys. Acta* **368**, 393–400.
- Spector, M., and Winget, G. D. (1980). *Proc. Natl. Acad. Sci. U.S.A.* **77**, 957–959.
- Spencer, D., and Possingham, J. V. (1961). *Biochim. Biophys. Acta* **52**, 379–381.
- Stemler, A. (1980). *Biochim. Biophys. Acta* **593**, 103–112.
- Stemler, A., and Radmer, R. (1975). *Science* **190**, 457–458.
- Stewart, A. G. (1980). *FEBS Lett.*, **114**, 67–72.
- Stewart, A. C., and Bendall, D. S. (1979). *FEBS Lett.* **107**, 308–312.
- Stewart, A. C., and Bendall, D. S. (1981). *Biochem. J.* **194**, 877–887.
- Tel-Or, E., and Avron, M. (1975). *Proc. Int. Congr. Photosynth., 3rd, 1974* pp. 569–578.
- Terry, N. (1977). *Plant Physiol.* **60**, 69–75.
- Theg, S. M., and Homann, P. H. (1982). *Biochim. Biophys. Acta* **679**, 221–234.
- Theg, S. M., and Sayre, R. T. (1979). *Plant Sci. Lett.* **16**, 319–326.
- Thibault, P. (1978a). *J. Theor. Biol.* **73**, 271–284.
- Thibault, P. (1978b). *C. R. Hebd. Seances Acad. Sci., Ser. D* **287**, 725–728.
- Van Kamela, K., and Wegman, K. (1977). *Plant Sci. Lett.* **8**, 1–5.
- van Niel, C. B. (1931). *Arch. Mikrobiol.* **3**, 1–112.
- Velthuys, B. (1975). *Biochim. Biophys. Acta* **396**, 392–401.
- Velthuys, B. (1980). *Annu. Rev. Plant Physiol.* **31**, 545–567.

- Velthuys, B., and Ames, J. (1974). *Biochim. Biophys. Acta* **333**, 85-94.
- Velthuys, B., and Kok, B. (1978a). *Proc. Int. Congr. Photosynth.* 4th, 1977 pp. 397-401.
- Velthuys, B., and Kok, B. (1978b). *Biochim. Biophys. Acta* **502**, 211-221.
- Vermaas, W. F. J., and Govindjee (1981a). *Proc. Indian Acad. Sci. Biol. Ser.* **47**, 581-605.
- Vermaas, W. F. J., and Govindjee (1981b). *Photochem. Photobiol.* **34**, 775-793.
- Vernon, L. P., and Shaw, E. R. (1969). *Biochem. Biophys. Res. Commun.* **36**, 878-884.
- Warburg, O. (1964). *Annu. Rev. Biochem.* **33**, 1-14.
- Warburg, O., and Krippahl, G. (1960). *Z. Naturforsch., B: Anorg. Chem., Org. Chem., Biochem., Biophys., Biol.* **15B**, 367-369.
- Warburg, O., and Lüttgens, W. (1944). *Naturwissenschaften* **32**, 301.
- Ward, R. (1975). *Arch. Biochem. Biophys.* **169**, 22-28.
- Weise, C., and Sauer, K. (1970). *Photochem. Photobiol.* **11**, 495-501.
- Wessels, J. J. C., and Borchert, M. T. (1978). *Biochim. Biophys. Acta* **503**, 78-93.
- Wessels, J. J. C., Van Alphen-VanWavern, O., and Voorn, G. (1973). *Biochim. Biophys. Acta* **292**, 741-752.
- Whittingham, C. P., and Bishop, P. M. (1963). *N.A.S.—N.R.C., Publ.* **1145**, 371-380.
- Whittingham, C. P., and Brown, A. H. (1958). *J. Exp. Bot.* **9**, 311-319.
- Willstätter, R., and Stoll, A. (1918). "Untersuchungen über die Assimilation der Kohlensäure." Springer-Verlag, Berlin and New York.
- Winget, G. D., and Spector, M. (1981). *Proc. Int. Congr. Photosynth.*, 5th, 1980 II, pp. 453-464.
- Wurmser, R. (1930). "Oxidations et Reductions." Presses Univ. de France, Paris.
- Wydrzynski, T., and Sauer, K. (1980). *Biochim. Biophys. Acta* **589**, 56-70.
- Wydrzynski, T., Zumbulyadis, N., Schmidt, P. G., and Govindjee (1975). *Biochim. Biophys. Acta* **408**, 349-354.
- Wydrzynski, T., Govindjee, Zumbulyadis, N., Schmidt, P. G., and Gutowsky, H. S. (1976a). *ACS Symp. Ser.* **34**, 471-487.
- Wydrzynski, T., Zumbulyadis, N., Schmidt, P. G., Gutowsky, H. S., and Govindjee (1976b). *Proc. Natl. Acad. Sci. U.S.A.* **73**, 1196-1198.
- Wydrzynski, T., Marks, S. B., Schmidt, P. G., Govindjee, and Gutowsky, H. S. (1978). *Biochemistry* **17**, 2155-2162.
- Yamamoto, Y., Doi, M., Tamura, N., and Nishimura, M. (1981). *FEBS Lett.* **133**, 265-268.
- Yamashita, T., and Butler, W. L. (1968). *Plant Physiol.* **44**, 435-438.
- Yamashita, T., and Tomita, G. (1974). *Plant Cell Physiol.* **15**, 69-82.
- Yamashita, T., Tsuji, J., and Tomita, G. (1971). *Plant Cell Physiol.* **12**, 117-126.
- Yocum, C. F., Yerkes, C. T., Blankenship, R. E., Sharp, R. R., and Babcock, G. T. (1981). *Proc. Natl. Acad. Sci. U.S.A.* **78**, 7507-7511.
- Zankel, K. (1971). *Biochim. Biophys. Acta* **245**, 373-385.
- Zankel, K. (1973). *Biochim. Biophys. Acta* **325**, 138-148.
- Zilinskas, B., and Govindjee (1974). *Plant Sci. Lett.* **3**, 219-227.

Thermoluminescence from Photosynthetic Apparatus

YORINAO INOUE
KAZUO SHIBATA

I. Introduction.....	508
II. Glow Curves.....	509
A. Thermoluminescence Bands.....	509
B. Measuring Conditions Affecting the Glow Curves.....	512
III. Characteristics of Bands.....	514
A. Z and Z _v bands.....	514
B. A, B ₁ , B ₂ , and C bands.....	515
C. Physical Constants.....	519
IV. Origin of Charges.....	521
A. Photosystems for Thermoluminescence.....	521
B. Relation to the Oxygen-Evolving System.....	522
C. Oscillation of Thermoluminescence.....	525
D. Dependence on the S states.....	527
V. Temperature-Jump Luminescence.....	531
References.....	531

ABBREVIATIONS

Adry	Acceleration of the deactivation reactions in the water-splitting enzyme Y
CCCP	Carbonyl cyanide <i>m</i> -chlorophenylhydrazone
Chl	Chlorophyll
DBMIB	2,5-Dibromo-3-methyl-6-isopropyl- <i>p</i> -benzoquinone
DCMU (Diuron)	3-(3,4-Dichlorophenyl)-1,1-dimethylurea
DCPIP	2,6-Dichlorophenolindophenol
PSI	Photosystem I
PSII	Photosystem II
RC	Reaction center
Tris	Trishydroxymethylaminomethane

ABSTRACT

The properties of thermoluminescence emitted from green plant materials are reviewed here in relation to the photosynthetic activities. Three thermoluminescence bands (A, B₁, B₂) out of the six bands are closely related to the photochemical reaction of photosystem II (PSII), in particular to the oxygen-evolving activity. Analysis of glow curves charged by short flash illumination revealed that two (B₁, B₂) of the three bands undergo four-cycle oscillation, which is dependent on the S state of the oxygen clock (see

Wydrzynski, Chapter 10, this volume), whereas the other one (A) shows the phenomenon of "enhanced charging" strictly dependent on the S_3 state. Based on these results, a scheme has been proposed in which the positive charges for emission of the three bands would be attributed to the respective S states in the oxygen clock. It was also revealed that each step of photo-oxidation of the S state has different sensitivity to low temperature so that the charging yield for the A band strongly depends on the illumination temperature, through the limitation in S_3 formation. The present confusion in thermoluminescence data from different research groups is partly attributable to the fact that this effect is not taken into consideration in both experiments and interpretation of the data.

I. Introduction

Thermoluminescence is a burst of light emission observed when irradiated organic or inorganic materials are subsequently warmed in darkness. The phenomenon popular for photosensitive semiconductors is generally accepted as due to thermally activated recombination of electrons and positive holes produced by irradiation and stabilized in frozen states at low temperature (see, e.g., Arnold, 1965). Arnold and Sherwood (1957) were the first to observe thermoluminescence from chloroplasts, subsequent to the discovery of delayed fluorescence from green plants by Strehler and Arnold (1951). Their experiments gave indications that the emission results from reversal of early processes of photosynthesis.

The primary photochemical event in photosynthesis is charge separation, formation of a negatively and positively charged pair of chemical species by the energy of absorbed light in the reaction center in thylakoid membrane (see Parson and Ke, Chapter 8, this volume). The positive and negative charges thus produced on the reaction center (RC) chlorophyll (Chl) and the primary electron acceptor (A), respectively, migrate through the electron transport system across the thylakoid membrane, and the reducing power derived from electrons is used for CO_2 fixation (see Govindjee, 1982), whereas the oxidizing power from positive holes is used to decompose water to evolve oxygen (Wydrzynski, Chapter 10, this volume).

At room temperature, some of such negative and positive charges in the reaction center are metastable and recombine spontaneously to release chemical energy. The released energy is emitted as fluorescence from Chl's, possibly through re-excitation of the RC Chl. Such emission is generally referred to as delayed fluorescence or delayed light emission (Lavorel, 1975; Amesz and van Gorkom, 1978; Malkin, 1977a,b; Govindjee and Jursinic, 1979). When the chloroplasts are cooled rapidly after irradiation or irradiated at low temperature, some of the metasta-

ble charges are stabilized. On warming such frozen chloroplasts, the stabilized positive and negative charges recombine, being thermally activated over the barrier of activation energy, so that light is emitted from Chl molecules excited by the energy released by the recombination. This chapter describes the phenomenology of thermoluminescence from green plant materials in relation to the origin of stabilized charges.

II. Glow Curves

A. Thermoluminescence Bands

Glow curves are obtained by recording emission intensity against temperature. Several peaks have been found in the glow curves of green plant materials. These peaks were, however, named differently by different authors, which may cause confusion in discussing the results reported by different groups. In the early studies, Arnold and Azzi (1968) found four luminescence bands peaking at -155 , -6 , $+30$, and $+55^{\circ}\text{C}$, and called them Z, A, B, and C bands, respectively. Shuvalov and Litvin (1969) found three peaks and named them with numbers: components II (-160°C), III (-15°C), and IV ($+20^{\circ}\text{C}$). In addition to these peaks from stabilized charges, they observed long-lived phosphorescence at -196°C and delayed emission above 0°C and called them components I and V, respectively. Three peaks found by Lurie and Bertsch (1974a) for isolated chloroplasts were designated as peaks 1 (-10°C), 2 ($+25^{\circ}\text{C}$), and 3 ($+40^{\circ}\text{C}$), respectively. Six luminescence peaks were separated in the more extensive observations by Sane *et al.* (1974) and by Ichikawa *et al.* (1975). The six peaks found by Sane *et al.* (1974) in the glow curve of intact spinach leaves excited continuously during cooling the sample from room temperature to liquid nitrogen temperature (Fig. 1) were designated as Z (118°K ; -155°C), I (230°K ; -43°C), II (257°K ; -16°C), III (275°K ; $+2^{\circ}\text{C}$), IV (290°K ; $+17^{\circ}\text{C}$), and V (320°K ; $+47^{\circ}\text{C}$), and the six peaks observed by Ichikawa *et al.* (1975) for intact spinach leaves (Fig. 2) were named Z (-160°C), Z_v (variable), A (-10°C), B₁ ($+25^{\circ}\text{C}$), B₂ ($+40^{\circ}\text{C}$), and C ($+55^{\circ}\text{C}$). The nomenclature by Ichikawa *et al.* is based on Arnold's system with partial modification, and this system will be used in the present chapter, referring to other nomenclatures used by several investigators, which are summarized in Table I. A mathematical curve resolution technique was applied by Vass *et al.* (1980) to the glow curves of intact chloroplasts in order to see overlapping peaks. They succeeded in separating seven glow peaks (two of them below 0°C and five above 0°C)

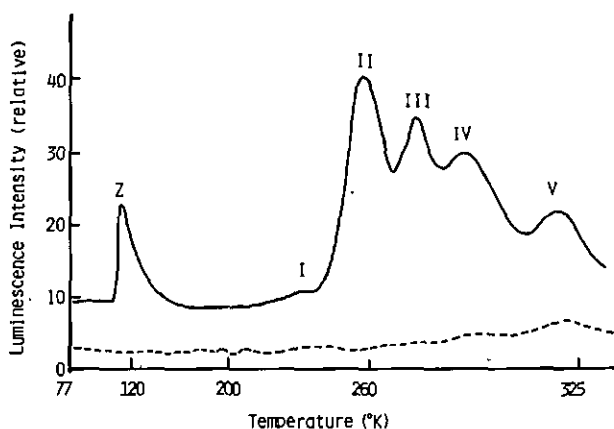

FIG. 1. Glow curves of spinach leaves frozen to 77°K. Solid curve, leaf frozen under illumination with white light of a medium intensity for 2 min; broken curve, dark-adapted leaf frozen in darkness. Heating rate was 10°K/min (Sane *et al.*, 1974).

in the temperature range between -80 to $+80^{\circ}\text{C}$. This implies that eight or nine glow peaks including the Z and Z_v bands are observable in plant materials.

The emission temperatures of a thermoluminescence peak observed by different investigators agree with each other within the range of variation due to differences in samples and measuring conditions such as apparatus, and heating rate. Each band has its characteristic emission temperature independent of excitation temperature (Table I), except

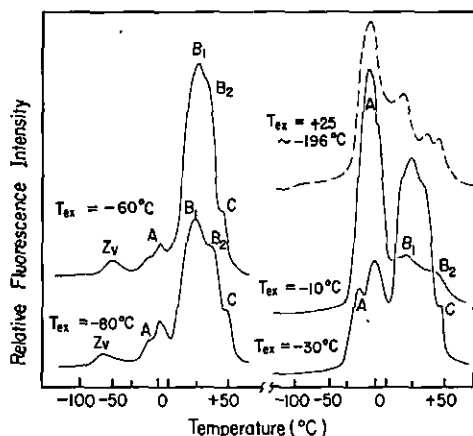

FIG. 2. Glow curves of intact spinach leaves measured after excitation in various conditions. Solid curve, excitation at a fixed low temperature indicated as T_{ex} on each curve. Broken curve, continuous excitation during freezing from $+25^{\circ}\text{C}$ to -196°C . Heating rate was 30°K/min (Ichikawa *et al.*, 1975).

TABLE I
Comparison of Glow Peaks Reported by Various Investigators

Author	Thermoluminescence glow peak (emission temperature)				
Arnold and Azzi (1968)	Z (-155°C)	A (-6°C)	B (+30°C)	C (+55°C)	
Shupalov and Litvin (1969)	II (-160°C)	III (-15°C)	IV (+20°C)	V (+55°C)	
Lurie and Berssch (1974a)	Z	peak 1 (-10°C)	peak 2 (+30°C)	peak 3 (+40°C)	(DLE)
Sane <i>et al.</i> (1974)	Z (118°K)	II (254°K)	IV (290°K)	V	
Sane <i>et al.</i> (1977)	Z (115°K)	I (236°K)	IV (290°K)	V	
Ichikawa <i>et al.</i> (1975)	Z (-160°C)	Z _v (variable)	A (-10°C)	B ₁ (+25°C)	C (+55°C)
			(D) ^a (+10°C)	B ₂ (+40°C)	

^aThese bands were absent in normal chloroplasts but appeared in the presence of DCMU (diuron).

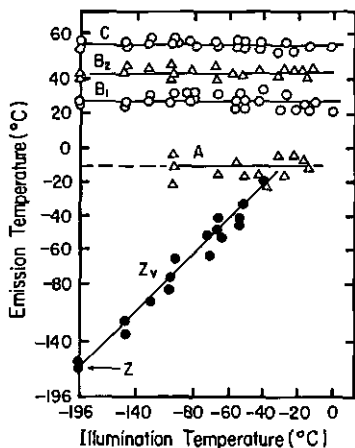

FIG. 3. Variation of emission temperature of the Z_v band dependent on excitation temperature (solid circles) as compared with constancy of emission temperatures of other bands (open circles and triangles) (Ichikawa *et al.*, 1975).

for the Z_v band. The emission temperature of this band observed by Ichikawa *et al.* (1975) varies, depending on the excitation temperature; the band appears at a temperature 10 to 30°C higher than the excitation temperature. This band is observed in the temperature range from -150°C to $+40^{\circ}\text{C}$ and, at higher temperatures, it merges into the more intense A band emitted at -10°C . Figure 3 shows the variable nature of the emission temperature of the Z_v band in contrast to the constancy of the emission temperatures of other bands.

Several glow peaks were observed for extracted Chls *a* and *b* (Krasnovsky and Litvin, 1974) and for photosynthetic bacteria (Fleishman, 1971; Govindjee *et al.*, 1977; also see Carithers and Parson, 1975). Most of the bands of photosynthetic bacteria arise from back reaction of primary reactors of photosynthesis, but some bands originate from Mg-protoporphyrin IX, a precursor of bacteriochlorophyll biosynthesis (Govindjee *et al.*, 1977).

B. Measuring Conditions Affecting the Glow Curves

Several factors are known to affect the glow curve: excitation temperature, heating rate, wavelength of excitation light, preillumination, and so on. Excitation by a flash(es) or continuous light may be given at a fixed low temperature before the sample is cooled down to liquid nitrogen temperature or may be given continuously during cooling the sample from room temperature to liquid nitrogen temperature. The glow curves are greatly affected by such temperature conditioning on excitation, which sometimes causes confusion in comparing the data obtained

by different investigators. This effect of excitation temperature was first pointed out by Arnold (1966), who found that the B band around $+25^{\circ}\text{C}$ was the highest when excited at -32°C , whereas the A band around -10°C was the highest when excited at -6°C . Rubin and Venediktov (1969) reported a great difference between the two glow curves of *Chlorella*, one obtained by excitation at a fixed temperature of -50°C and the other by continuous excitation during freezing the sample from room temperature down to -50°C . Such an effect of excitation temperature is summarized in Figs. 2 and 5. The excitation at a fixed temperature below -40°C yields high B_1 and B_2 bands with a low A band, while the excitation above -20°C yields a high A band with lower B_1 and B_2 bands. Excitation during cooling from room temperature to liquid nitrogen temperature usually yields a high A band, and the emission temperature of the composite ($B_1 + B_2$) band appears to be shifted toward a lower temperature of about $+10^{\circ}\text{C}$, which agrees with the temperature of the DCMU-insensitive peak reported by Rubin and Venediktov (1969). DCMU (Diuron) blocks electron flow between QI and QII (see Cramer and Crofts, Chapter 9, this volume.) Illumination above 0°C before cooling yields only the B_1 and B_2 bands; the A band cannot be charged at an excitation temperature higher than the emission (trapping) temperature.

Heating rate also affects the glow curve. Arnold (1966) stated that a heating rate slower than 20° per min would not yield detectable emission for glow peaks. In later studies, however, the heating rate as slow as $10^{\circ}\text{C}/\text{min}$ was used by Sane *et al.* (1974) for better resolution of bands. An example of the effect of heating rate is shown in Fig. 4 (Ichikawa *et al.*, 1975). At slower rates (curves A and B), the A band appears relatively higher than the B_1 or B_2 band, whereas, at rates higher than $20^{\circ}\text{C}/$

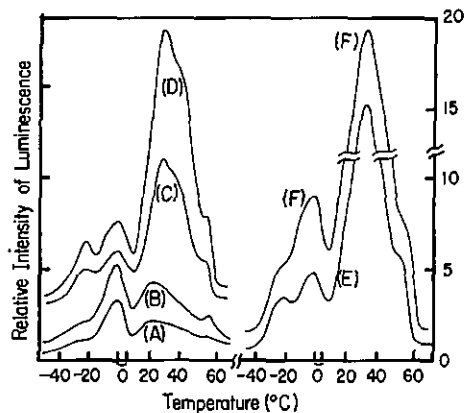

FIG. 4. Effect of heating rate on glow curves. Sample spinach leaves were illuminated at -40°C and heated at rates of 11° (A), 19° (B), 24° (C), 31° (D), 63° (E), and $85^{\circ}\text{C}/\text{min}$ (F) (Ichikawa *et al.*, 1975).

min (curves C to F), the B_1 and B_2 bands are higher than the A band. This effect of heating rate could be another cause for confusion in comparing the data reported by different authors. However, the effect does not cause qualitative change and is less than the effect of excitation temperature. The effects of preillumination and the wavelength of actinic light will be discussed in later sections.

III. Characteristics of Bands

A. Z and Z_v Bands

The sharp Z band located at -160°C has been described by many investigators. Arnold and Azzi (1968) in their early studies found that this band is not directly related to photosynthetic reaction, because it is present in the glow curve of a leaf boiled for inactivation of photochemical reactions and because it is excited much more efficiently by blue light than by red light. The excitation and emission spectra of this band were studied by Shuvalov and Litvin (1969), who demonstrated that only blue and blue-green light is effective in charging the Z band, whereas orange and red light is almost ineffective. The excitation maximum was around 420 nm with a broad shoulder around 490 nm. They also showed that the emission spectrum of this band has a maximum in the far red region at 740 nm. Sane *et al.* (1974) also measured the emission spectrum of the Z band and located its maximum at 740 nm, but they reported that the Z band could be excited not only by blue light but also by red light or by γ -ray irradiation. They also found that DCMU does not affect this band. Based on these findings, Sane *et al.* considered the Z band as phosphorescence from a triplet state of chlorophyll. This idea needs to be further tested because 740 nm emission, at low temperature, is usually assigned to fluorescence from PSI, and, based on studies of Krasnovsky, phosphorescence is expected to be at higher wavelengths.

The Z_v band, is an extremely weak band which may have been first observed by Sane *et al.* (1974) as a part of Peak I. Subsequently, Ichikawa *et al.* (1975) found the variable nature of its emission temperature depending on the excitation temperature (Fig. 3). Desai *et al.* (1977) studied its nature precisely and proposed a mechanism that includes partial charging of two different (charge) reservoirs at different excitation temperatures; at temperatures lower than 173°K (-100°C), the Z_v band is a part of Arnold and Azzi's Z band tailing toward higher temperatures, whereas, above 173°K , it is a part of Sane's Peak I. This proposition is based on the assumption that the two bands, Z_v and peak I, are indepen-

dent and different glow peaks. However, judging from the low emission temperature of peak I (-43°C), it seems more natural to assume that these two bands are of the same origin; namely, the Z_v band appears at the emission temperature of peak I under the excitation condition used by Sane *et al.*

The Z_v band was absent in the glow curves of etiolated leaves and isolated subchloroplasts particles (Ichikawa *et al.*, 1975), and it was present in the glow curves of wheat leaves greened under intermittent flash illumination (Inoue *et al.*, 1976c). In these leaves, both PSI and PSII reaction centers exist but the activity to oxidize water to evolve oxygen is specifically absent. The treatment with DCMU at low concentration abolishes both Z_v and A bands. However, these bands behave differently on heat treatment; the A band is suppressed by heating at 45°C , whereas the Z_v band is inactivated at 55°C (Ichikawa *et al.*, 1975). Observations on PSII enriched subchloroplast particles isolated from pea chloroplasts (J. Mullett and Y. Inoue, unpublished data, 1980) demonstrated the presence of the Z_v band in their glow curve. It is therefore likely that the Z_v band arises from charges stabilized near the PSII reaction center, but the more precise location of the charges is not clear.

B. A, B_1 , B_2 , and C Bands

Among the six thermoluminescence peaks found for green plants, the three bands, A, B_1 and B_2 , are most closely related to the photochemical reactions in photosynthesis. Arnold and Azzi (1968) showed that preheating of spinach leaves up to 90°C abolishes all the A, B, and C bands but not the Z band. They concluded that these three bands arise from recombination of the charges produced by photosynthetic photochemical reaction and stabilized at low temperature on various charge carriers of the electron transport chain. They also reported that a mutant of *Scenedesmus*, lacking the PSII activity, emitted none of these three bands, and they inferred from this observation that the PSII reaction center is responsible for the three bands.

The effect of DCMU on these three bands is of great interest in this context. However, the results obtained by various investigators are not consistent with each other. Arnold and Azzi (1968) reported that DCMU abolishes the A and C bands, but the B band is insensitive to it. Shuvalov and Litvin (1969) obtained a similar result for the A and B bands, although they made no comment on the C band. Rubin and Venediktov (1969) also studied the effect of DCMU on the bands of *Chlorella* cells by excitation at a fixed temperature of -50°C , and they reported that both A and B bands are sensitive to DCMU. The A band completely disap-

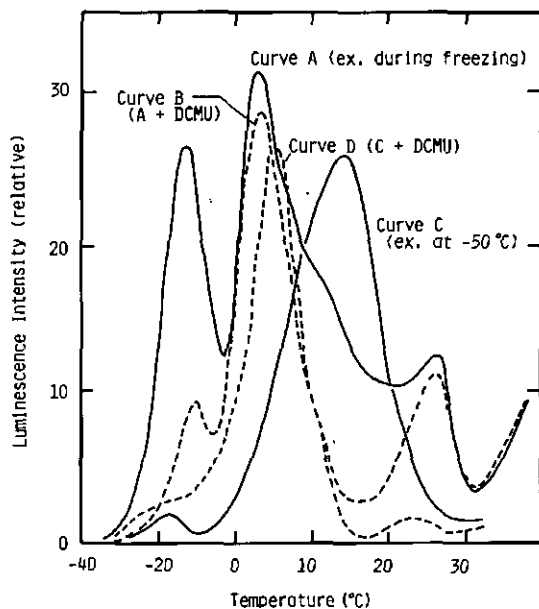

FIG. 5. Glow curves of intact *Chlorella* cells measured after continuous excitation during freezing (curves A and B) and after excitation at a fixed temperature of -50°C (curves C and D). Curves A and C are the results obtained for normal cells and curves B and D for DCMU (diuron)-treated cells (Rubin and Venediktov, 1969).

peared on the treatment with DCMU, and the B band was replaced by a new band around $+10^{\circ}\text{C}$ on the treatment (Fig. 5). The emission temperature ($+10^{\circ}\text{C}$) of this new band agrees with that of the strong band observed for nontreated cells by continuous excitation during freezing from room temperature to -50°C . Lurie and Bertsch (1974a) titrated the DCMU sensitivities of these three bands; the DCMU concentrations for one-half inhibition was 5×10^{-9} , 5×10^{-4} , and 5×10^{-8} M for A, B_1 and B_2 bands, respectively. They found an enhancement of the B_1 band at lower DCMU concentrations although they did not describe the shift of the B_1 band toward lower temperatures. This seems to be the same phenomenon as the appearance of a new band observed by Rubin and Venediktov (1969) and by Ichikawa *et al.* (1975). The effect of DCMU was also studied by Sane and his colleagues; peaks I, III, and IV of intact leaves were lowered by DCMU, whereas peak V was intensified (Desai *et al.*, 1975; Sane, 1975). The effect was studied more precisely as a function of DCMU concentration with isolated chloroplasts (Sane *et al.*, 1977). As shown in Table II and Fig. 6, peak II was absent in nontreated chloroplasts but appeared at low concentrations of 10^{-6} to 10^{-5} M and

TABLE II

Effect of Different Concentrations of DCMU (diuron) on the Intensity of Glow Peaks from Spinach Chloroplasts^a

Glow peak	DCMU concentration (M)				
	Control	10 ⁻⁶	10 ⁻⁵	10 ⁻⁴	10 ⁻³
Z	46	42	42	42	42
I	182	92	60	—	—
II	absent	32	63	312	288
IV	422	404	400	180	184
V	88	108	128	240	280

^aReprinted from Sane *et al.*, 1977.

increased in height about 10-fold at 10⁻⁴ to 10⁻⁵ M, whereas peak I was abolished completely by 10⁻⁴ M DCMU and peak IV was lowered by about one-half at 10⁻³ M. Since the DCMU-sensitive nature of the A band is well-established by many investigators, peak I must be the A band or a composite of Z_v and A bands, and peak II intensified by DCMU may be the new peak found by Rubin and Venediktov (1969) and by Ichikawa *et al.* (1975). According to Sane *et al.* (1977), peak I is dominant in normal chloroplasts and peak II is seen only as a shoulder. Ichikawa *et al.* (1975) also reported the effect of DCMU. They observed the development of a new peak around +10°C (designated as D in Table I) accompanied by complete disappearance of the A and Z_v bands and a partial lowering of the B₁ and B₂ bands. A similar observation was reported by Demeter *et al.* (1979). These investigators also found inten-

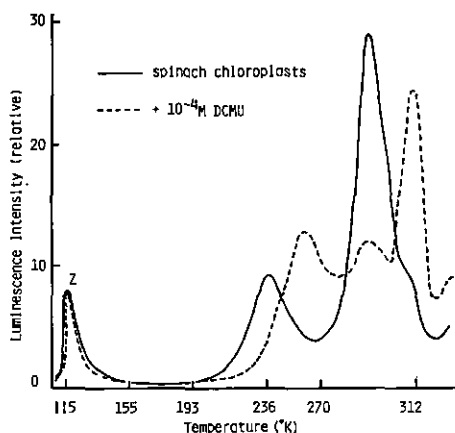

FIG. 6. Glow curves of isolated spinach chloroplasts. Solid curve, normal chloroplasts; broken curve, DCMU (diuron)-treated (0.1 mM) chloroplasts (Sane *et al.*, 1977).

sification of the C band by DCMU, which agrees with the result reported by Sane *et al.* (1977) for peak V, but not with the early observation by Arnold and Azzi (1968) that the C band was abolished by DCMU. The C band is observable for dark-grown spruce leaves (Inoue *et al.*, 1976b), but it is sometimes not detected with isolated chloroplasts. Sane *et al.* (1977) considered that this band originates from PSI photoreaction, based on their observation that it accounts for about 33% of the total thermoluminescence yield in the presence of 10^{-4} M DCMU (See Table II). Decisive assignment for this band, however, has to wait for a more crucial experiment, for instance with a PSI-lacking mutant.

Many observations made by various groups on the effect of DCMU in different excitation conditions with different samples may be summarized as follows. Upon treatment with DCMU, both or either B_1 and/or B_2 bands undergo a shift in emission temperature to a lower temperature around $+10^\circ\text{C}$. Possibly, the new peak thus formed results from recombination of the electron on the "primary" electron acceptor of PSII with a positive hole, whereas the electrons beyond the inhibition site of DCMU on the electron transport between PSII and PSI are involved in the emission of the B_1 and B_2 bands of normal chloroplasts. The shift in emission temperature may imply a difference in the activation energy needed for the stabilized electrons to be released to recombine with positive holes.

Several other chemicals are known to affect thermoluminescence. Carbonyl cyanide *M*-chlorophenylhydrazone (CCCP) and NH_2OH are known to prohibit the emission of all of the glow peaks (Arnold and Azzi, 1968). The strong effect of CCCP seems to be related to its Adry action (Renger, 1973) since 2,6-dichlorophenolindophenol (DCPIP), a typical Adry reagent, also prohibits thermoluminescence (Inoue *et al.*, 1977). As opposed to CCCP, the effect of uncoupler amines are not strong. 2,5-dibrom-3-methyl-6-isopropyl-*p*-benzoquinone (DBMIB) affects thermoluminescence in a similar way to DCMU (Demeter *et al.*, 1979). An oxidant, ferricyanide, at high concentration, is inhibitory, but reductants ascorbate and dithionite are not. The effect of several other chemicals that affect thermoluminescence are well documented in Demeter *et al.*'s paper (1979). The biochemical actions of these chemicals at various low temperatures, the condition of thermoluminescence measurements, may not necessarily be the same as those at room temperature, and they should be known in order to interpret their actions on thermoluminescence.

The treatment of chloroplasts with Tris, which specifically inhibits the oxygen-evolving activity, abolished the B_1 and B_2 bands, but the A band remained unchanged (Inoue *et al.*, 1977). On reactivation of the oxygen-

evolving activity by washing the treated chloroplasts with reduced DCPIP, the B₁ and B₂ bands were partially recovered. Heat treatment of chloroplasts at 45°C for 5 min abolished the A, B₁, and B₂ bands related to photosynthesis (Arnold and Azzi, 1968; Ichikawa *et al.*, 1975). Treatment of isolated chloroplasts with acidic medium also affects thermoluminescence. The effect of low pH was very similar to that of DBMIB (Demeter *et al.*, 1979). It is suggested that protonation of the component responsible for the +25°C band inhibits its charge recombination process. Inoue (1981) found that separation of the B₁ and B₂ bands on the glow curve of isolated chloroplasts is much better at acidic pH, and he suggested that the effect of pH could be the cause for the difference in the shape of glow curves between isolated chloroplasts and intact leaves.

C. Physical Constants

Thermoluminescence reflects the energy stored in the products reduced and oxidized by illumination. At room temperature, these positively and negatively charged products recombine to emit delayed fluorescence, but, at low temperature, they require energy to be activated from the frozen stabilized states. Accordingly, the glow curve can provide basis for calculation of the activation energy, the depth of each trap.

The energy of the first excited singlet state of chlorophyll is about 1.8 eV as determined from the maximum (680 nm) of fluorescence and delayed fluorescence (Strehler and Arnold, 1951). The redox potential produced by the photoreaction in PSII is about 0.82 eV. Therefore, the amount of energy, which may be invested for stabilization of the metastable states of separated charges, is 0.98 eV. Such a large amount of stabilization energy may be the cause for the slow back reaction of photosynthetic process and may be reflected as the low quantum yield of delayed fluorescence.

The intensity of thermoluminescence while warming the sample is determined by two factors: the number of charges in the reservoir responsible for the band and the generation of excited Chl's from recombination of opposite charge pairs. The rate of re-excitation of Chl by recombination is greater at higher temperatures, but the number of charges reserved will be smaller with increasing temperature. A peak of emission intensity at a certain fixed temperature is interpreted as a result of these opposite effects as a function of temperature. Randall and Wilkins (1945) formulated such a process as follows:

$$I = -C(dn/dt) = Cns \cdot e^{-E/kT}$$

where I is the emission intensity, n is the number of electrons or positive holes at time t in the traps having the depth of activation energy E , s is the frequency factor of recombination, and T is absolute temperature. The two unknown parameters, E and s , in this equation can be calculated according to the method proposed by Grossweiner (1953):

$$E = \frac{1.461 \times kT_{1/2}T_{\max}}{T_{\max} - T_{1/2}}$$

$$s = \frac{BE \cdot e^{E/kT_{\max}}}{kT_{\max}^2}$$

where $T_{1/2}$ and T_{\max} are the temperatures that give the one-half maximal and maximal intensities, respectively, on the rising phase of a glow peak, and B is the heating rate.

By means of these equations, Arnold and his colleagues estimated the activation energy for A, B, and C bands to be 0.46–0.52, 0.52–0.60 and 0.56–0.64 eV, respectively (Arnold and Sherwood, 1959; Arnold, 1966; Arnold and Azzi, 1968). Similar calculations were made by Lurie and Bertsch (1974b), Tataka *et al.* (1981) and Vass *et al.* (1980), and the results are summarized in Table III. There are considerable differences

TABLE III
Physical Constants for Individual Thermoluminescence Bands Calculated by Various Investigators

Author	Glow peak	Emission temperature (°C/K)	Activation energy (eV)	Frequency factor (sec ⁻¹)	Half-life
Lurie and Bertsch (1974b)	1	-5°C	0.799	1.5 × 10 ¹⁴	0.020 sec
	2	+15°C	0.476	7.0 × 10 ⁷	1.851 sec
	3	+35°C	0.567	9.9 × 10 ⁸	1.655 sec
Vass <i>et al.</i> (1980)	-20	-24°C	0.81	2.5 × 10 ¹²	0.05 sec
	-10	-12°C	0.67	6.9 × 10 ⁸	0.90 sec
	+10	+12°C	0.73	3.7 × 10 ⁸	11.0 sec
	+20	+17°C	1.04	8.5 × 10 ¹³	11.0 sec
	+30	+28°C	1.12	4.1 × 10 ¹⁴	50.0 sec
	+45	+44°C	1.16	1.6 × 10 ¹⁴	605.0 sec
	+70	+69°C	0.89	5.1 × 10 ⁸	4770.0 sec
Tataka <i>et al.</i> (1981)	Z	118°K	0.58	5.16 × 10 ²³	0.001 psec
	I	236°K	0.52	2.48 × 10 ⁹	220 msec
	II	261°K	0.64	4.48 × 10 ¹⁰	1.27 sec
	III	283°K	0.79	2.42 × 10 ¹²	7.73 sec
	IV	298°K	1.10	1.04 × 10 ¹⁷	29.03 sec
	V	321°K	1.32	1.42 × 10 ¹⁹	17.66 min

in the energies calculated by different investigators, which are probably due to the errors in estimating the rise course of insufficiently resolved glow peaks. This difficulty is discussed in the paper by Tataka *et al.* (1981).

IV. Origin of Charges

A. Photosystems for Thermoluminescence

Involvement of PSII in the thermoluminescence from green plant materials was proposed by Arnold and Azzi (1968), who revealed that a *Scenedesmus* mutant specifically lacking the PSII activity emits none of the A, B, and C bands. They also found that another mutant lacking the PSI activity emits all the three bands as normal cells. This has been generally accepted in connection with the fact that the delayed fluorescence from chloroplasts originates from PSII.

As opposed to this view, Sane and his colleagues (Desai *et al.*, 1975; Sane, 1975; Sane *et al.*, 1980) suggested involvement of PSI photoreaction for certain glow peaks. Their observations are that peak V (a) is insensitive to DCMU; (b) is excited by far red light at 740 nm; and (c) is stronger in the glow curve of PSI enriched subchloroplast particles (Table IV). However, attempts to detect glow peaks emitted from PSI reaction center-enriched particles by other investigators were unsuccessful (Lurie and Bertsch, 1974a; Ichikawa *et al.*, 1975). Demeter *et al.* (1979) found that the glow curve of bundle sheath chloroplasts is extremely weak as compared with that of mesophyll chloroplasts and suggested that PSI photoreaction is not related to thermoluminescence.

TABLE IV

Percentage of Contribution of Different Glow Peaks to the Total Luminescence in PSI and PSII Enriched Fractions Obtained from Spinach Chloroplasts by Treatment with Digitonin^a

Glow peak	Fraction		
	D-0	D-10	D-40
I and II	11.7	12.2	3.2
IV	14.6	32.7	23.8
V	73.7	55.1	73.0
Total luminescence	171	156	63

^aReprinted from Sane *et al.*, 1977.

They also found that HgCl_2 , an inhibitor of the PSI electron transport, does not affect any of the glow peaks of isolated chloroplasts. These observations seem to indicate that thermoluminescence arises from PSII but not from PSI. However, it must be emphasized that the experimental conditions (particularly heating rates and mode of illumination) were different in various experiments cited.

B. Relation to the Oxygen-Evolving System

The relation to the oxygen-evolving system was studied by observing the development of thermoluminescence bands during greening of etiolated leaves. When etiolated angiosperm leaves are illuminated with intermittent flashes (repeated at intervals of a few minutes), pale green chloroplasts develop. In these chloroplasts, the pigment systems of PSI and PSII are functionally developed, but the oxygen-evolving system remains latent. The glow curve of such chloroplasts showed a distinct Z_v band and a very weak C band, but was completely devoid of the three bands of A, B_1 , and B_2 , which are known to be related to photosynthetic reaction (Fig. 7).

When the long interval intermittent illumination was switched to continuous light or to repetitive flashes at short intervals of a few seconds, the latent oxygen-evolving system was rapidly activated and, simultaneously, the three bands appeared (Inoue *et al.*, 1976b). Similar development of the three glow peaks was observed for gymnosperm leaves

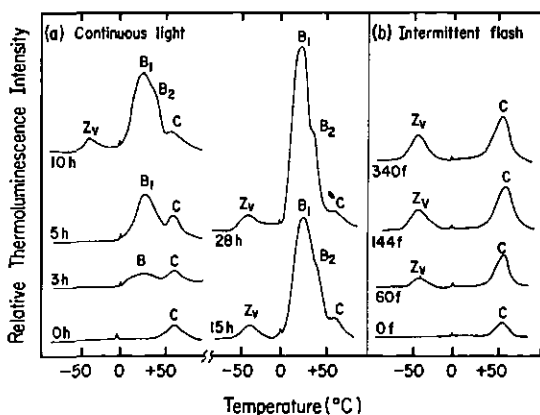

FIG. 7. Development of glow peaks during greening of wheat leaves under continuous (a) and intermittent (b) illumination. Excitation was made by 1-min illumination by red light at -60°C . Figures on curves stand for the time of continuous illumination in hours (h) for (a) and the number of flashes ($2 \mu\text{s}$) given in every 5 min for (b) (Inoue *et al.*, 1976b).

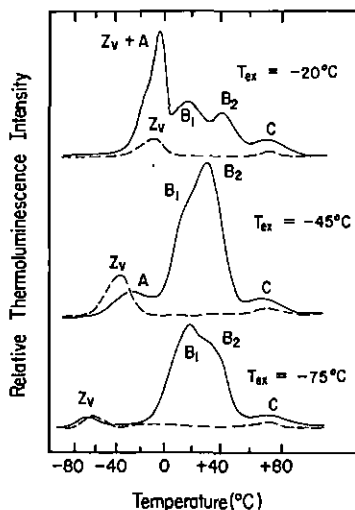

FIG. 8. Glow curves of light-grown (solid curves) and dark-grown (broken curves) spruce leaves measured at three different excitation temperatures (T_{ex}) (Inoue *et al.*, 1976c).

(Inoue *et al.*, 1976c), in which the two pigment systems had developed in complete darkness (Oku *et al.*, 1978), but the oxygen-evolving activity and the three thermoluminescence bands were lacking (Fig. 8). On illumination of such leaves with continuous light, the activity to evolve oxygen and the three thermoluminescence bands appeared in a short period (Fig. 9). Such photoactivation of the oxygen-evolving system is a multiquantum process driven by more than two sequential photoevents occurring at a short interval of a few seconds (Cheniae and Martin, 1973; Inoue, 1975), and the development of the three bands required completely the same program of flash repetition as needed for the pho-

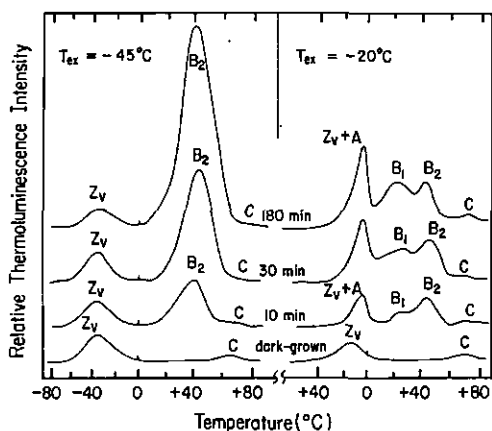

FIG. 9. Development of glow peaks during photoactivation of dark-grown spruce leaves. The dark-grown leaves were illuminated with dim red light for the period indicated for each curve. The glow curves were measured after excitation at two different temperatures (T_{ex}) (Inoue *et al.*, 1976c).

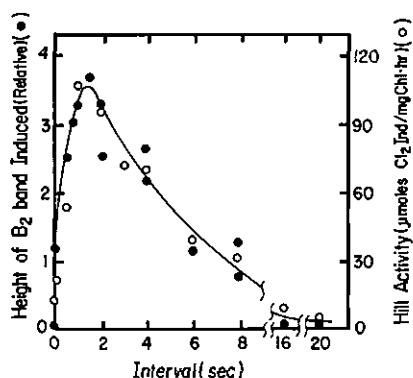

FIG. 10. Effects of flash interval on the development of glow peaks and on the generation of the Hill activity in dark-grown spruce chloroplasts during photoactivation by repetitive flashes. Solid and open circles are the relative height of the B₂ band and the Hill activity, respectively, generated by 600 flashes repeated at various intervals (Inoue *et al.*, 1976c).

toactivation that is shown in Fig. 10 (Inoue *et al.*, 1976a; Inoue and Shibata, 1977). During the photoactivation, there occurred a functional change of the Mn enzyme involved in the oxidation of water (Cheniae and Martin, 1971), and a similar functional change was deduced from thermoluminescence. Inoue (1976) demonstrated that the glow curve of Mn deficient *Scenedesmus* cells is devoid of the B band and, on addition of Mn²⁺ to the deficient cells followed by shortly spaced flash illumination, the B band appeared rapidly with concomitant reactivation of the oxygen-evolving system (Fig. 11).

It seems clear from these data that the positive charges for the three glow peaks of A, B₁, and B₂ are those stabilized in the oxygen-evolving system, most probably as oxidized Mn atoms in the "Mn-enzyme-protein" (see Wydrzynski, chapter 10, this volume). The Z_v band was observed in intermittently illuminated angiosperm leaves and in dark-grown gymnosperm leaves. An observation by J. Mullet and Y. Inoue

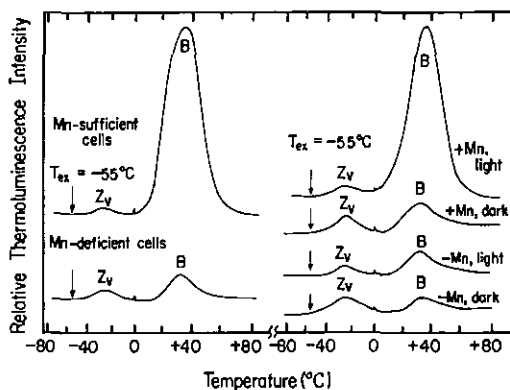

FIG. 11. Glow curves of Mn-deficient and Mn-sufficient *Scenedesmus* cells (left), and the enhancement of the B band by addition of Mn²⁺ in the light and in the dark (right) (Inoue, 1976).

(unpublished, 1980) that the Z_v band is found for partially purified PSII particles suggests that this band also originates from PSII.

C. Oscillation of Thermoluminescence

According to the Joliot–Kok model for photosynthetic oxygen evolution, four positive charges stored stepwise with flashes on an imaginary charge accumulator, S , cooperate to oxidize two molecules of water (see Wydrzynski, Chapter 10, this volume). The charge accumulation steps are designated as S_0 to S_4 states with S_4 as the most oxidized state for oxygen evolution. As is well-known, the charge accumulator undergoes a quadruple cyclic change to evolve oxygen at every four flashes.

From the close relationship of the three thermoluminescence bands to the oxygen-evolving activity discussed in Section IV,B, it is inferred that the positive charges responsible for the three bands are stored on the S system, so that the three bands may undergo quadruple oscillation as found for delayed fluorescence (Barbieri *et al.*, 1970; Arnold and Azzi, 1971), when excited by saturating short flashes. In fact, Hardt and Malkin (1973) found such an oscillation for several types of triggered luminescence including a heat-triggered one, and Inoue and Shibata (1978) demonstrated that the composite B band ($B_1 + B_2$) of isolated chloroplasts undergoes a quadruple oscillation with maxima after the second and sixth flashes and minima after the fourth and eighth flashes (Fig. 12). In the latter experiment, chloroplasts were illuminated with flashes at room temperature and then rapidly cooled down as usual to -50°C in 3 sec. If one assumes that the dominant S state in dark-adapted chloroplasts is the S_1 state, the first maximum after the 2nd flash is to be the luminescence from the positive charges on the S_3 state. The phase of thermoluminescence oscillation is advanced by one flash from the phase

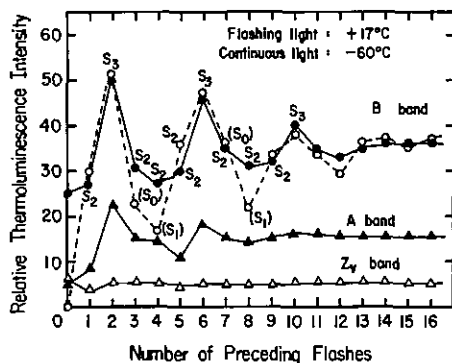

FIG. 12. Oscillation of glow peak height upon excitation by flashes. Open circles, B-band height measured after high temperature excitation at $+17^\circ\text{C}$ with flashes; solid circles, B-band height measured after the low temperature excitation at -65°C subsequent to the pre-illumination by flashes (Inoue and Shibata, 1978a).

of oxygen evolution. This may be because the S_4 state decays rapidly to release oxygen before the positive charges were stabilized by cooling. The same phase shift was found for the oscillation of a slowly decaying component of delayed fluorescence (Barbieri *et al.*, 1970). The B_1 and B_2 bands can be observed separately with chloroplasts suspended in an acidic medium, and a flash excitation experiment for such chloroplasts indicated that the S_2 state is mainly responsible for the B_2 band whereas the S_3 state is responsible for the B_1 band (cf. dotted glow curves in Fig. 14).

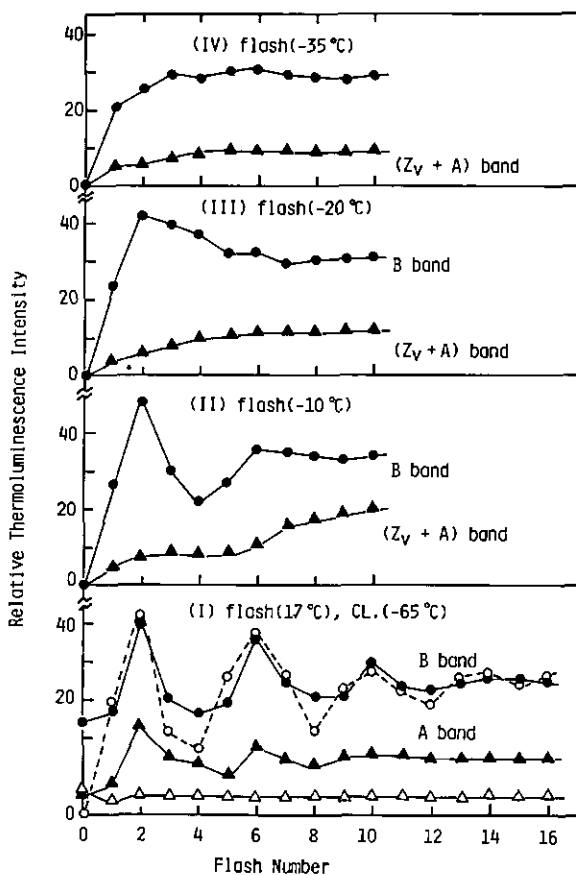

FIG. 13. Oscillation of glow peak height measured at four different temperatures. Broken line with open circles in trace (I) is the normal oscillation pattern at room temperature, and traces (II) to (IV) are the patterns deformed by respective low temperatures (Inoue and Shibata, 1978b).

TABLE V
Temperature Dependency of Each Step of S Oxidation as Estimated from the Oscillation of Thermoluminescence^a

Reaction	Temperature dependency
S_0 or $S_1 \rightarrow S_2$	Proceeds below -65°C
$S_2 \rightarrow S_3$	Blocked below -35°C
$S_3 \rightarrow S_4$	Blocked below -20°C
Binding of H_2O to open S sites	Blocked below -10°C

^aReprinted from Inoue and Shibata, 1978b.

The quadruple oscillation of thermoluminescence is marked above 0°C and, below 0°C , the oscillation pattern is deformed as shown by Fig. 13 (Inoue and Shibata, 1978b). At -10°C , the oscillation proceeded up to the sixth flash, but not thereafter. This is interpreted as due to the fact that the first cycle of S conversion is completed, but the second is blocked in the middle. Possibly, the water molecules for the second cycle are no longer accessible to the center of oxygen evolution below the freezing point of water. At -20°C , the oscillation proceeded up to the second flash, but no variation thereafter. This may imply that photoconversion of S_3 to S_4 was blocked at this temperature. At -35°C , only the first step of oscillation could be driven normally, but no more clear change thereafter. Probably, only the photoconversion of S_1 to S_2 could proceed at this temperature. Based on these data, Inoue and Shibata (1978b) proposed that each photoconversion step of the S states has a different sensitivity to low temperature as listed in Table V. The sensitivity is higher for the photoconversion to higher S states.

D. Dependence on the S state

The close relationship between the B_1 and B_2 bands and the S states was thus found by the oscillatory behavior of these bands, and the B_1 and B_2 bands were assigned to originate from the S_3 and S_2 states, respectively. The fact that the three bands, A, B_1 , and B_2 , appeared simultaneously on photoactivation of the inactive oxygen-evolving system suggested a similar close correlation of the A band to the S system. The charging of the A band has been found to be strongly dependent on photoconversion of the S state (Läuffer *et al.*, 1978; Inoue, 1981). Such dependency was found to be closely related to the strong effect of excitation temperature on the A-band height relative to other bands as discussed in Section II,B.

Among the three bands related to the oxygen-evolving system, the A

band is greatly different from the B_1 and B_2 bands in its charging efficiency. The B_1 and B_2 bands are effectively charged by illumination with a single saturating flash, whereas the A band required continuous illumination to be charged; the charging efficiency of the B_1 and B_2 bands was much higher than that of the A band (Desai *et al.*, 1977; Inoue and Shibata, 1978a). Another marked difference between the A band and the B_1 and B_2 bands lies in their dependencies on excitation temperature. The B_1 and B_2 bands were charged efficiently in a wide temperature range between +30 and -65°C , whereas the A band was charged only when excitation was given between -5°C and -20°C .

However, when the sample chloroplasts were preilluminated with two flashes before freezing, the strict conditions for charging the A band changed greatly. The preillumination itself does not charge the A band but, after the preillumination, the A band is readily charged to the maximum intensity even at 77°K. This phenomenon was denoted as "A-band enhancing effect." The enhancement is regulated by a mechanism affected by preillumination. Inoue (1981) proposed that the S_3 state is responsible for the enhancement for the following reasons: (a) the A-band enhancement was maximally induced by double flash preillumination and oscillated depending on the number of preilluminating flashes (Fig. 14); (b) the temperature dependence of the A-band enhancing effect agrees with that of the photoconversion of S_2 to S_3 , as listed in Table V; (c) the preilluminated state decayed in darkness with a decay constant equal to that of the S_3 state; and (d) on charging the A band, the B_1 band previously charged by preilluminating flashes was lowered, which indicates that the A band is charged at the expense of the B_1 band.

The conditions needed for the A band to be charged are summarized as follows: (a) the S_3 state must be formed beforehand; and (b) excitation of the S_3 state must be at a temperature that is low enough to block oxygen evolution. These conditions for the A band indicate that the positive charge pool for the A band is the S_4 state, so that the excitation of the S_3 state has to be made at the low temperature so as to prohibit S_4 to S_0 conversion. At room temperature, the S_4 state will readily be converted to S_0 for oxygen evolution, so that we cannot observe the S_4 state as thermoluminescence.

Another deduction drawn from this mechanism is that the mechanism accounts for the steep dependency of the A-band intensity on excitation temperature. Inoue (1981) demonstrated that the temperature sensitivity of the A-band enhancement effect not only agrees with the temperature dependency of the photoconversion of S_2 to S_3 , but also agrees with that of the A-band height measured by excitation of dark-adapted chloroplasts with continuous light at various fixed tempera-

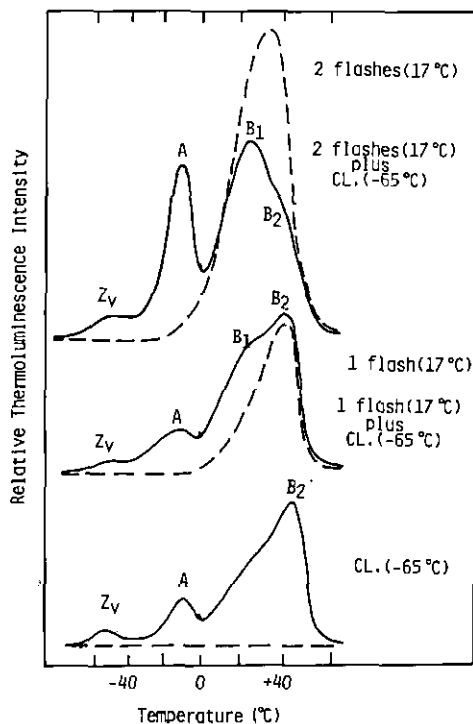

FIG. 14. Effect of flash preillumination on the A-band height. Chloroplasts (pH 5.0) were illuminated with a single (middle, solid) and double flashes (upper, solid) at $+17^{\circ}\text{C}$ before being cooled down to -65°C to receive the post low-temperature excitation. Dotted glow curves are those measured after the single (middle) or double (upper) flash preillumination without the post low-temperature excitation. The bottom glow curve is the reference curve measured after the low temperature excitation with no flash preillumination (Inoue, 1981).

tures. This implies that the steep temperature dependence of the A band discussed in Section II,B is a reflection of the temperature sensitivity of the photoconversion of S_2 to S_3 . Probably, the low yield of S_3 state at low temperatures determines the lower limit of the temperature range, and the higher limit is determined by the trapping (emission) temperature of the A band itself. This explains the large difference between the two glow curves, one obtained by excitation at a fixed low temperatures and the other by excitation continued during freezing. Most likely, the early part of the continuous excitation during freezing converts S_2 to S_3 and, then, if a part of the S_3 state is frozen, the subsequent illumination charges the A band.

1. A WORKING HYPOTHESIS

The preceding view for the three thermoluminescence bands in relation to the S states is summarized in Fig. 15, together with possible intermediates from water molecules associated with the system. It is assumed in this scheme that a specific thermoluminescence band arises from recombination between the positive charge(s) on a specific S state

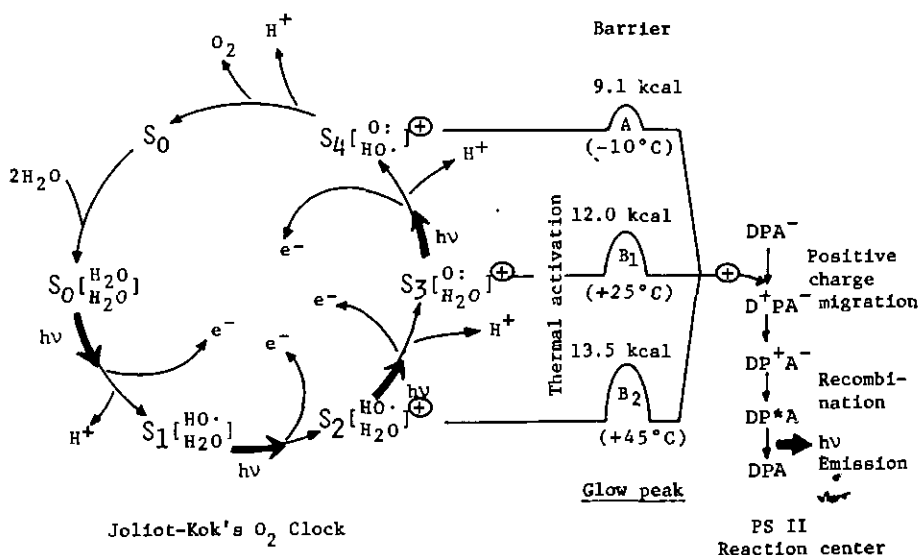

FIG. 15. A working hypothesis. Positive charge traps in the oxygen-evolving system postulated for the three glow peaks. DPA stands for the donor (D), the RC Chl (P), and acceptor (A) of PSII and the Joliot-Kok *S* states (also see Wydrzynski, Chapter 10, this volume) are shown with positively charged intermediates produced from two H₂O molecules, according to the H⁺-release pattern of 1:0:1:2 for the four flashes (Inoue, 1981).

and the negative charge(s) on a nonspecific electron acceptor (A) on the acceptor side of PSII reaction center (P); namely, the emission temperature of each band reflects the activation energy for the positive charge on a *S* state to migrate back to the reaction center over the energy barrier between P and the specific *S* state. This is a mechanism, which may be called *oxidation side theory* and is derived from consideration focused on the nature of positive holes. The opposite point of view, *reduction side theory*, may not be neglected since some inhibitors of electron transport on the reducing side of PSII are known to affect glow curves. Also, some evidence shows that electrons stabilized on different carriers on the reducing side of PSII yield glow curves peaking at different temperatures (Demeter *et al.*, 1979). However, caution has to be paid to the interpretation of the data with inhibitors. Inhibitors not only block the electron transport in both processes of charging and recombination but also inhibit the turnover of the *S* state.

It seems interesting to speculate in relation to the scheme of Fig. 15 that the positive charges are located on the three *S* states (S₂, S₃ and S₄) out of the four intermediate states of the two molecules of water postulated according to the proton release pattern of 1:0:1:2 by Fowler (1977)

and Saphon and Crofts (1977), but no positive charge on the S_1 state. These three S states are known to have different lifetimes, and their properties seem to be reflected in the characteristics of the three thermoluminescence bands discussed in this chapter. We would suppose that the agreement in number between the three positively charged S states involved in the oxygen clock and the three thermoluminescence bands appearing on activation of the latent oxygen-evolving system may not be fortuitous. Probably, each of the three thermoluminescence bands in question reflects the respective positive charges on the intermediates involved in the water oxidation in photosynthesis.

V. Temperature-Jump Luminescence

In contrast to the glow curves, the temperature-jump method is cleaner in the sense that conditions are constant and defined during illumination as well as observation of luminescence. Mar and Govindjee (1971) discovered that if temperature is increased suddenly (by injecting hot water), a pulse of emission occurs in preilluminated algae and chloroplasts. This phenomenon was further studied by Jursinic and Govindjee (1972), and more thoroughly by Malkin and Hardt (1973), and, was used to calculate activation energy of delayed luminescence. The 100 msec delayed light component gave a value of $\sim 0.75\text{--}0.87$ eV; these values are consistent with the activation energy value of ~ 0.6 eV, as they represent several steps in the electron transport (see Malkin, 1977a). In order to ascertain further details of glow peaks and their behavior, it may be useful to follow the kinetics of decay of luminescence at various peaks after preplanned temperature-jumps.

Acknowledgments

We are grateful to Govindjee and P. V. Sane for their invaluable suggestions and criticism during the preparation of this manuscript. We regret that some of the suggestions were not included in the final text.

REFERENCES

- Amesz, J., and van Gorkom, H. J. (1978). *Annu. Rev. Plant Physiol.* **29**, 47–66.
Arnold, W. (1965). *J. Phys. Chem.* **69**, 788–791.
Arnold, W. (1966). *Science* **154**, 1046–1049.
Arnold, W., and Azzi, J. R. (1968). *Proc. Natl. Acad. Sci. U.S.A.* **61**, 29–35.

- Arnold, W., and Azzi, J. R. (1971). *Photochem. Photobiol.* **14**, 233-240.
- Arnold, W., and Sherwood, H. (1957). *Proc. Natl. Acad. Sci. U.S.A.* **43**, 105-114.
- Arnold, W., and Sherwood, H. (1959). *J. Phys. Chem.* **12**, 357-367.
- Barbieri, G., Delosme, R., and Joliot, P. (1970). *Photochem. Photobiol.* **12**, 357-367.
- Carithers, R. P., and Parson, W. W. (1975). *Biochim. Biophys. Acta* **387**, 194-211.
- Cheniae, G. M., and Martin, I. F. (1971). *Biochim. Biophys. Acta* **253**, 163-181.
- Cheniae, G. M., and Martin, I. F. (1973). *Photochem. Photobiol.* **11**, 441-457.
- Demeter, S., Herczeg, T., Droppa, M., and Horváth, G. (1979). *FEBS Lett.* **100**, 321-324.
- Desai, T. S., Sane, P. V., and Tataka, V. G. (1975). *Photochem. Photobiol.* **21**, 345-350.
- Desai, T. S., Tataka, V. G., and Sane, P. V. (1977). *Biochim. Biophys. Acta* **462**, 775-780.
- Fleishman, D. (1971). *Photochem. Photobiol.* **14**, 65-70.
- Fowler, C. F. (1977). *Biochim. Biophys. Acta* **459**, 351-363.
- Govindjee, ed. (1982). "Photosynthesis: Carbon Assimilation and Plant Productivity" Vol. II. Academic Press, New York.
- Govindjee, and Jursinic, P. (1979). *Photochem. Photobiol. Rev.* **4**, 125-205.
- Govindjee, Desai, T. S., Tataka, V. G., and Sane, P. V. (1977). *Photochem. Photobiol.* **25**, 119-122.
- Grossweiner, L. I. (1953). *J. Appl. Phys.* **24**, 1306-1309.
- Hardt, H., and Malkin, S. (1973). *Photochem. Photobiol.* **17**, 433-440.
- Ichikawa, T., Inoue, Y., and Shibata, K. (1975). *Biochim. Biophys. Acta* **408**, 228-239.
- Inoue, Y. (1975). *Biochim. Biophys. Acta* **396**, 402-413.
- Inoue, Y. (1976). *FEBS Lett.* **72**, 279-282.
- Inoue, Y. (1981). *Biochim. Biophys. Acta* **634**, 309-320.
- Inoue, Y., and Shibata, K. (1977). In "Biological Solar Energy Conversion" (A. Mitsui, S. Miyachi, A. San Pietro, and S. Tamura, eds.), pp. 109-128. Academic Press, New York.
- Inoue, Y., and Shibata, K. (1978a). *Proc. Intl. Congr. Photosynth., 4th, 1977* pp. 211-221.
- Inoue, Y., and Shibata, K. (1978b). *FEBS Lett.* **85**; 193-197.
- Inoue, Y., Oku, T., Furuta, S., and Shibata, K. (1976a). *Biochim. Biophys. Acta* **440**, 772-776.
- Inoue, Y., Ichikawa, T., and Shibata, K. (1976b). *Photochem. Photobiol.* **23**, 125-130.
- Inoue, Y., Furuta, S., Oku, T., and Shibata, K. (1976c). *Biochim. Biophys. Acta* **449**, 357-367.
- Inoue, Y., Yamashita, T., Kobayashi, Y., and Shibata, K. (1977). *FEBS Lett.* **82**, 303-306.
- Jursinic, P., and Govindjee (1972). *Photochem. Photobiol.* **15**, 331-348.
- Krasnovsky, A. A., Jr., and Litvin, F. F. (1974). *Photochem. Photobiol.* **20**, 133-149.
- Krasnovsky, A. A., Jr., Lebedev, N. N., and Litvin, F. F. (1975). *Dokl. Akad. Nauk SSSR* **225**, 207-210.
- Läufer, A., Inoue, Y., and Shibata, K. (1978). In "Chloroplast Development" (G. Akoyunoglou and J. H. Argyroudi-Akoyunoglou, eds.), pp. 379-387. Elsevier/North Holland Biomedical Press, Amsterdam.
- Lavorel, J. (1975). In "Bioenergetics of Photosynthesis" (Govindjee, ed.), pp. 223-317. Academic Press, New York.
- Lurie, S., and Bertsch, W. (1974a). *Biochim. Biophys. Acta* **357**, 420-428.
- Lurie, S., and Bertsch, W. (1974b). *Biochim. Biophys. Acta* **357**, 429-438.
- Malkin, S. (1977a). In "Primary Processes of Photosynthesis" (J. Barber, ed.), pp. 349-431. Elsevier/North-Holland, Amsterdam.
- Malkin, S. (1977b). In "Photosynthesis I" (A. Trebst and M. Avron, eds.), pp. 473-491. Springer-Verlag, Berlin and New York.
- Malkin, S., and Hardt, H. (1973). *Biochim. Biophys. Acta* **305**, 292-301.
- Mar, T., and Govindjee (1971). *Biochim. Biophys. Acta* **226**, 200-203.

- Oku, T., Inoue, Y., Sanada, M., Matsushima, K., and Tomita, G. (1978). *Plant Cell Physiol.* **19**, 1-6.
- Randall, J. T., and Wilkins, M. H. F. (1945). *Proc. R. Soc. London, Ser. A* **184**, 366-389.
- Renger, G. (1973). *Biochim. Biophys. Acta* **314**, 390-402.
- Rubin, A. B., and Venediktov, P. S. (1969). *Biofizika* **14**, 105-109.
- Sane, P. V. (1975). *Proc. Natl. Symp. on Thermoluminescence and Its Applications*, pp. 279-297. Bhabha Atomic Research Centre, Bombay, India.
- Sane, P. V., Tatake, V. G., and Desai, T. S. (1974). *FEBS Lett.* **45**, 290-294.
- Sane, P. V., Desai, T. S., Tatake, V. G., and Govindjee (1977). *Photochem. Photobiol.* **26**, 33-39.
- Sane, P. V., Desai, T. S., and Tatake, V. G. (1980). *Z. Naturforsch., C: Biosci.* **35C**, 289-292.
- Saphon, S., and Crofts, A. R. (1977). *Z. Naturforsch., C: Biosci.* **32C**, 617-626.
- Shuvalov, V. A., and Litvin, F. F. (1969). *Mol. Biol. (Kiev)* **3**, 59-73.
- Strehler, B. L., and Arnold, W. (1951). *J. Gen. Physiol.* **34**, 809-820.
- Tatake, V. G., Desai, T. S., Govindjee, and Sane, P. V. (1981). *Photochem. Photobiol.* **33**, 243-250.
- Vass, I., Horváth, G., Herczeg, T., and Demeter, S. (1980). *FEBS Lett.* **116**, 293-297.

Part V

Photophosphorylation

Mechanism of ATP Synthesis*

DONALD R. ORT
BRUNO A. MELANDRI

I. Chemiosmotic Coupling.	539
A. The Basic Postulates.	539
B. Energetic Considerations.	541
C. Proton-Translocating Systems.	544
D. Differences between Chemiosmotic Coupling and Williams's Two-Phase Coupling Model.	548
II. Structural Organization of Coupling Reactions and Components.	550
A. Orientation of the Charge-Generating and Proton-Producing Reactions.	550
B. Spatial Distribution of the Coupling Factor Enzyme Complex.	551
C. Phosphorylating Unit.	553
III. The Transmembrane Electrochemical Hydrogen Ion Gradient.	554
A. The Kinetics of Formation of the Electrochemical Gradient of Protons and Its Relationship to the Induction of Phosphorylation.	555
B. Photophosphorylation in Steady State Conditions.	563
C. ATP Formed by Artificial Ion Gradients.	566
D. Delocalization of Coupling.	567
IV. Stoichiometries of Photosynthetic Energy Conversion.	571
A. Chloroplast Stoichiometries.	572
B. Bacterial Stoichiometries.	578
References.	583

ABBREVIATIONS

CCCP	Carbonyl cyanide <i>m</i> -chlorophenylhydrazone
CF ₀ and F ₀	Intrinsic membrane portions of coupling factor enzyme complex
CF ₁ and F ₁	Extrinsic membrane portions of coupling factor enzyme complex
Cyt	Cytochrome
DBMB	2,5-Dibromo-3-methyl-6-isopropyl- <i>p</i> -benzoquinone
DCCD	Dicyclohexyl carbodiimide
DCMU	3-(3,4-Dichlorophenyl)-1,1-dimethylurea
ΔC_{ATP}	Phosphoryl group transfer potential of ATP formation reaction
ΔG_{redox}	Electron transfer potential
$\Delta \bar{\mu}$	Electrochemical potential
Δp	Proton motive force
$\Delta \psi$	Transmembrane electrical potential difference

*The literature search for this contribution was completed in 1981.

EDTA	Ethylenediaminetetraacetic acid
HEPES	<i>N</i> -2-hydroxylpiperazine- <i>N'</i> -2-ethanesulfonic acid
MOPS	3-(<i>N</i> -morpholino)propanesulfonic acid
P870	Primary electron donor in some photosynthetic bacteria
P700	Primary electron donor of photosystem I
PCMB	<i>p</i> -Chloromercuribenzenesulfonic acid
PS	Photosystem
<i>q</i>	Degree of coupling
<i>Rp.</i>	<i>Rhodopseudomonas</i>
<i>Rs.</i>	<i>Rhodospirillum</i>
Z_{eH}	Number of moles of protons translocated per equivalent of electrons transferred
Z_{HP}	Number of moles of protons translocated per mole ATP hydrolyzed

ABSTRACT

This chapter deals with the processes involved in the coupling of photosynthetic electron transport to the phosphate group-transfer reactions of ADP-phosphorylation. In our view the major principle of the mechanism of chemiosmotic coupling, the essential role of proton activity gradients has been verified. There can be little doubt that the arrangement of redox components in photosynthetic membranes and the mechanism of their interaction allow for the direct transformation of redox energy into a transmembrane electrochemical potential difference of hydrogen ions. There is a multicomponent enzymatic complex inserted into photosynthetic membranes which can transform the energy of the electrochemical potential of hydrogen ions into the phosphate group transfer potential of ATP. The equivalence, both kinetic and energetic, of the electrical and chemical components of the proton gradient in phosphorylating ADP seems well established. However, the concept of chemiosmotic coupling which has evolved over the past decade has somewhat parochial boundaries. It is this minimal model which we outline in Section I,A and subsequently use as a "straw man" to assess the agreement of experimental results and predictions of chemiosmosis.

As we shall see, the minimal model has not always proved adequate to explain observed phenomena. Much of the unexplained data come from studies in which the presteady state characteristics of the phosphorylation process were investigated. In many instances it has been observed that there are difficulties regarding the magnitude of $\Delta\mu$ in comparison to ΔG_{ATP} . There is more flexibility regarding the relative sizes of the proton motive force and the rates of phosphorylation than is allowed by the minimal model. Specifically there appear to be instances where ATP formation depends on electron transport more directly than through the proton motive force only. Lastly, in some instances the electron transfer reactions and the ATP synthesizing reactions appear to interact more closely than would be expected if this coupling were mediated only by protons in the bulk aqueous phase.

We reiterate that these observations do not refute the general concept of chemiosmotic coupling. Preliminary models are naturally simplistic, and as research proceeds to specify the particulars of the mechanism, any preliminary model will almost certainly require modification. In the future it seems likely that greater emphasis on membrane-water interface phenomena and perhaps even intramembrane phenomena will have to be incorporated into the model. The modifications may include a lowered emphasis on the role of the bulk of the inner aqueous phase.

I. Chemiosmotic Coupling

The mechanism of coupling of the redox reactions of photosynthetic electron transport to the group transfer reaction of ADP-phosphorylation has been the subject of intensive theoretical and experimental research. Historically, the first proposals for a mechanism of ATP formation were modeled according to the analogous reaction in substrate level phosphorylation (see Jagendorf, 1975; Melandri, 1977). In the last decade, however, Mitchell's chemiosmotic hypothesis (Mitchell, 1968, 1976) has gained considerable experimental support and is now the main working hypothesis for the interpretation of experimental results related to photosynthetic and oxidative ATP synthesis. It is the purpose of this section to review the essential tenets of the minimal hypothesis for chemiosmotic coupling. However, since the reader should already be familiar with the basic concepts of this hypothesis we will emphasize the *most important consequences of the model which can be experimentally tested*. Finally, the proposals by Williams (1961, 1978a, b), which in part oppose Mitchell's theory and in part present a more general and less detailed view of the problem, will be discussed.

A. The Basic Postulates

The central tenets of Mitchell's hypothesis (see also Jagendorf, 1975) are

Postulate 1: The redox reactions of photosynthetic electron transport are coupled reversibly to the active translocation of protons across the membrane which forms a closed vesicle. There is a definite and fixed stoichiometry between protons translocated and electrons transferred. This stoichiometry is derived from the molecular mechanism of the proton pump. The postulate requires that the electron transfer components be arranged asymmetrically in the membranes so that their reaction mechanisms can operate vectorially and in a defined direction across the membrane. As an additional, but not essential assumption, it is proposed that the active translocation of protons results directly from the uptake and release of protons by the functional groups of the electron transfer components during their reduction and oxidation. This is brought about by an alternating arrangement of electron and hydrogen carriers (or in more elaborate nonlinear pathways introduced later) (Mitchell, 1976).

Postulate 2: Proton translocation across the membrane can also occur

by a reversal of the ATP-synthesizing reactions catalyzed by a reversible ATPase. The direction of the ATPase-mediated proton transport is the same as that of the electron transfer-mediated proton flux. This vectorial mechanism of the ATPase requires an asymmetrical structure of the enzyme complex. A defined H^+ /ATP stoichiometry for the enzyme complex is dictated by the molecular mechanisms of the enzymatic catalysis.

Postulate 3: Both the ATPase-dependent and the redox reaction-dependent proton translocating processes are electrogenic, reversible mechanisms operating in parallel but independently across the same membrane. Therefore, they are each capable of generating a difference in proton chemical activity as well as electrical charge across the membrane. The difference in electrochemical potential of H^+ across the membrane ($\Delta\mu_{H^+}$) can be formally separated into an osmotic (concentration-dependent) component and an electrostatic ($\Delta\psi$) (membrane potential($\Delta\psi$)-dependent) component. The electrochemical potential difference of protons across the membrane is generally expressed as the proton motive force (Δp)

$$\Delta p = \frac{\Delta\bar{\mu}_{H^+}}{F} = \Delta\psi - 2.3 \frac{RT}{F} \Delta pH \quad (1)$$

which represents the difference of μ_{H^+} (kJ mole^{-1}) across the membrane divided by the Faraday constant ($F = 96.5 \text{ kJ mole}^{-1} \text{V}^{-1}$). When expressed in mV and at 30°C , Eq. (1) takes the form:

$$\Delta p = \Delta\psi - 60 \Delta pH \quad (2)$$

Postulate 4: The biomembrane across which the H^+ translocating systems operate is considered to be an inert dielectric layer, endowed with a very reduced conductivity to ions in general, and to protons in particular. The membrane encloses an aqueous phase (from here on termed the internal phase) to form a closed compartment. Thus, the proton-translocating redox reactions and the proton-translocating ATP synthesizing reactions share two common aqueous phases which are separated by the membrane. Mitchell terms this membrane the *coupling membrane*. Any disorganization of the membrane structure (e.g., by a detergent) or any alteration of its low proton conductivity (e.g., by uncouplers or ionophores) will result in a loss in efficiency of the coupling and ultimately in the complete energetic uncoupling of the redox reactions from ATP synthesis. Interactions of protons with the structural components of the membrane (other than the functional components of

the proton pumps) are not thought to play a direct role in the mechanism of coupling. The process of energy transduction is accomplished through the reversible interaction of the redox carriers and of the H^+ -ATPase with the two aqueous phases of different H^+ electrochemical potentials.

B. Energetic Considerations

Chemiosmotic coupling imposes precise energetic limitations on the thermodynamic entities (forces) and the kinetic behavior (flows) of a phosphorylating system, that can be employed as diagnostic tools for the study of energy transduction associated with a membrane system. According to the hypothesis, energy transfer between redox reactions and ATP synthesis is mediated exclusively by the Δp . The measurement of the extent of the Δp is therefore the pivotal point in determining any energy balance. Unfortunately, the extent of Δp and the techniques used for its estimation are perhaps the most controversial issues in all the literature of bioenergetics.

In principle, the maximal work (chemical or of other nature) that can be performed utilizing the energy corresponding to the translocation of one mole of protons from a phase at high electrochemical potential to one at low potential is measured by the Δp and amounts to

$$F \Delta p = 96.5 \times 10^{-3} \Delta p [\text{kJ mole}^{-1}] = 23.08 \times 10^{-3} \Delta p [\text{kcal mole}^{-1}]$$

(if Δp is expressed in mV). The Δp represents, therefore, the thermodynamic force driving the flow of protons through the membrane energy transducers (redox or ATPase proton pumps) and should be equal to the other chemical forces driving these energy transducers. These chemical forces are in turn measured by the free energy changes associated with the redox reactions and with the hydrolysis of ATP. In a first rough approximation, we can treat all membrane transducers as reversible systems in an equilibrium situation with the electrochemical potential difference. Using equilibrium thermodynamics, it is expected that*

$$\Delta G_{\text{ATP}} = Z_{\text{HP}} F \Delta p \quad (3a)$$

*In Eq. (3) the proton motive force (Δp) is expressed by the $\bar{\mu}_i$ of the hydrogen ions in the inner aqueous compartment of the vesicle minus the $\bar{\mu}_i$ of the hydrogen ions in the outer compartment.

where Z_{HP} = number of moles of protons that must be translocated per mole of ATP hydrolyzed and

$$\Delta G_{\text{redox}} = Z_{e\text{H}} F \Delta p \quad (3b)$$

where $Z_{e\text{H}}$ = number of moles of protons that must be translocated per equivalent of electrons transferred. In these relationships an ideal energy balance exists among all the forces of the system. The Z coefficients therefore represent the energetically determined, minimum stoichiometries of the H^+ -ATPase and of the redox pumps. It follows from Eqs. (3a) and (3b) that the theoretical overall stoichiometry, Z_{ep} , of redox-linked phosphorylation results from the theoretical stoichiometries of the two different proton pumps:

$$\Delta G_{\text{redox}} = Z_{ep} \Delta G_{\text{ATP}} \quad (3c)$$

and since Δp is the same for both translocators

$$Z_{ep} = Z_{e\text{H}}/Z_{\text{HP}} \quad (4)$$

Thus far we have treated the phosphorylating system as an ideal reversible energy transducer with an efficiency of 100%. This is hardly the case in real systems since maximal efficiency can be achieved only at infinitely slow rates where irreversibility losses are eliminated. There are always energy losses associated with finite reaction rates since theoretical efficiencies are attained in a reversible system only at equilibrium. The more rapid the reaction, the farther it is from equilibrium and the greater the irreversibility losses (Walz, 1979). The chemical reactions in a battery have been used to illustrate the nature of irreversibility losses (Good and Bell, 1980), and it is useful to consider this example here. In a battery an excess of free electrons is produced at one pole of the battery and a deficiency of electrons at the other pole. The maximum energy available from the chemical reactions is equivalent to the open-circuit voltage, that is, the work potential of each electron when the current flow is zero. However, when current flow occurs, the chemical reactions proceed more rapidly and irreversibility losses are encountered. The result of these irreversibility losses is a drop in voltage delivered by the battery to the external load. It follows that the less the external load on the battery, the more efficient its operation but the lower the amount of work performed. Low work production also results when the external load on the battery is very large, since efficiency falls drastically as the voltage delivered to the external load drops. It is a well-known property of electric potential generating systems that the rate of work done is maximal when the voltage drop across the external load is equal to the voltage drop

across the generator's internal resistance. Thus, the greatest work output is achieved when the generating system is operating at 50% efficiency. These principles should apply to many biological systems (Odum and Pinkerton, 1955) including the electric potential generating reactions of photosynthetic membranes. In the chemiosmotic paradigm dissipative flows of protons and other ions across the membrane are unavoidable and contribute significantly to the decrease of the efficiency of the system (Katchalsky and Curran, 1965; Rottenberg, 1978, 1979; Walz, 1979). The practical result of these considerations is that the maximum work performed in generating a proton gradient, or the maximal work obtained from a proton gradient in a real system, is never as large as the maximal theoretical values predicted by Eq. (3a-c). The energetic necessities of the cell may well require that energy transducing organelles opt for maximum energy output rather than high efficiency. Stucki (cited in Walz, 1979) has suggested that mitochondria operating in an open system (where ATP is continuously consumed by the energy requiring processes in a cell) maximize the energy output at the expense of efficiency.

The evaluation of stoichiometric coefficients from Eqs. (3a) and (3b) always yields an underestimate of the number of electrons or protons required to produce a molecule of ATP. Equations (5a) and (5b) pertain to a real and not idealized phosphorylating system in which exergonic redox reactions drive the endergonic translocation of protons and the resulting difference in potential of protons in turn drives the endergonic synthesis of ATP.

$$\Delta G_{\text{redox}} = \frac{Z_{eH}}{q_{eH}} F \Delta \phi > Z_{eH} F \Delta \phi \quad (5a)$$

$$\Delta G_{\text{ATP}} = Z_{\text{HP}} q_{\text{HP}} F \Delta \phi < Z_{\text{HP}} F \Delta \phi \quad (5b)$$

The apparent experimental stoichiometries always include corrective factors measuring implicitly the efficiency of the system as an energy transducer. The parameters q_{eH} and q_{HP} in Eq. (5) are called degrees of coupling and always have a value less than 1. A value of $q = 1$ would correspond to an ideal system, with perfect efficiency.

The preceding considerations on the consequences of imperfect coupling pertain to the maximal output force obtainable by an energy transducer. This maximal output force can be measured when the rate of the output process approaches zero. Under these conditions the system is in a special steady state (often called static head) in which the rate of free energy loss due to irreversibility is at a minimum, but not at zero since

this state would be a true equilibrium involving no "leaks" and no measurable reaction (Caplan, 1971). Such a situation may be approached experimentally, for example, when the maximum extent of the proton uptake or of the Δp generated by the photosynthetic reactions are measured, or when the maximal ATP:ADP ratio for photophosphorylation (i.e., the maximum ΔG_{ATP}) is evaluated in conditions of no net ATP synthesis, but even then there are likely to be unavoidable side reactions dissipating energized states so that the hoped-for equilibrium is probably better described as a steady state involving some irreversibility losses.

Similar disequilibrium considerations can be applied to states of the system other than static heads. In principle any state can be described by a set of phenomenological equations which relate rates of processes (flows) and thermodynamic forces, linked together by stoichiometric coefficients and by degrees of coupling. As we have seen, correlations between flows and forces are not sufficient to evaluate stoichiometries since degrees of coupling are involved in the reactions, and often the corrections introduced by these parameters are quantitatively important (Rottenberg, 1979).

A distinguishing feature of chemiosmotic coupling is the prediction that when the Δp is kept constant, the rates of the redox reactions and of ATP synthesis become independent of each other and are a function only of Δp . Thus for a given set of experimental conditions (say, for example, a given ATP:ADP concentration ratio and a given phosphate concentration), the rate of phosphorylation is determined directly by the magnitude of the Δp and only indirectly by the rate of the electron transfer reactions that form and maintain the proton gradient. This behavior originates from the independence of the two different proton translocators operating across the membrane (the redox pump and the H^+ -ATPase), whose interaction is postulated to occur only through the proton gradient. Thus the overall efficiency of a chemiosmotic system results from the combination of the partial stoichiometries and partial degrees of coupling (Caplan and Essig, 1969; Rottenberg, 1979) of the independent energy transducers. This distinguishing feature of a chemiosmotic system offers a critical point for testing the validity of Mitchell's hypothesis for photosynthetic ATP synthesis.

C. Proton-Translocating Systems

1. REDOX PUMPS

In the original hypothesis, specifically concerned with the respiratory electron transport chain, Mitchell proposed that the redox carriers are

arranged in the membrane in such a way as to form a redox loop which alternates electron carrying components (cytochromes, iron-sulfur centers) and proton (as hydrogen) carrying components (flavoproteins, ubiquinones). A similar scheme, drawn for higher plant and bacterial photosynthesis is presented in Figs. 1a and b. In this model electron transporters carry out a transmembrane charge separation. In a subsequent step the newly reduced compound is protonated and the reducing equivalents are translocated back to the original side of the membrane in an electrically neutral fashion. In this way the original charge separation of the electrogenic arm of the loop is maintained and delocalized into the aqueous bulk phases facing the membrane (for relevant reviews, see Hauska and Trebst, 1977; Junge, 1977; Crofts and Wood, 1978; Witt, 1979; also see Junge and Jackson, Chapter 13, this volume).

The salient characteristics of this scheme are (a) the strict structural arrangement of the electron carriers, since any disorganization of the loop resulting in redox interactions other than transmembrane will result in shunting the redox loop and uncoupling the electron flow from the proton pump and from ATP synthesis; and (b) the stoichiometry between protons translocated and electrons transferred is strictly one H^+ per electron per loop. For this stoichiometry it is essential that all protonatable redox groups possess a functional pK_a higher than the steady state pH of the phase with which they interact; otherwise they would not be protonated and could not act as proton carriers. For some components, e.g., quinone coenzymes, this may be questionable.

In a subsequent proposal, elaborated to explain some discrepancies observed in the behavior of the respiratory chain, Mitchell (1976) proposed a nonlinear electron transfer scheme (called the Q cycle) in which quinone coenzymes are suggested to form two different couples (Q/QH and QH/QH₂), each interacting with different components of the chain. In this way one electron during its interaction with the quinone pool crosses the membrane twice and promotes the translocation of two protons (see also Wraight, Chapter 2, this volume). A stoichiometry of $2H^+$ per electron per cycle results.

The strict H^+/e^- stoichiometry defined by the reaction mechanism of the Q cycle is not required if a more general mechanism of coupling between redox components and proton translocation is considered. It has been suggested that proton uptake and release can result from coupling within the protein of a redox component and by the protonation-deprotonation equilibria of lateral groups of the apoprotein (the so-called membrane Bohr effect) (Papa, 1976). In this view any electron carrier, irrespective of its prosthetic group, can be considered a candi-

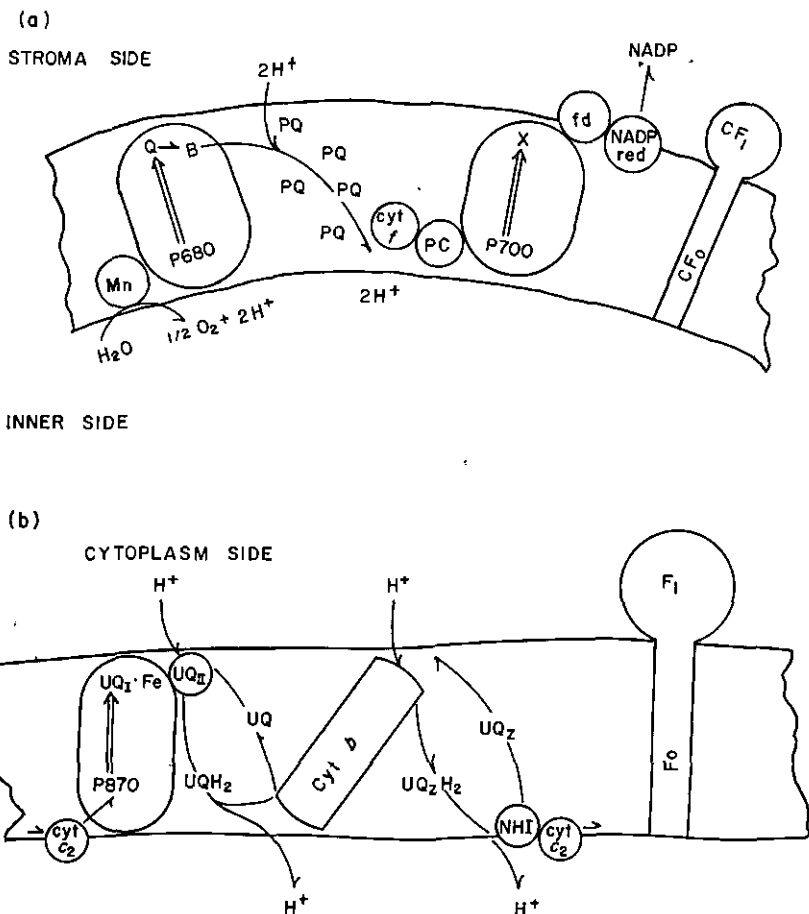

FIG. 1. (a) Representation of the arrangement of the linear electron transport components in the lamellar membrane of chloroplasts. The meaning of the symbols are as follows: Mn, the manganese containing enzyme complex involved in water splitting; P680, reaction center chlorophyll(s) of PSII; Q, quencher, believed to be the "primary" electron acceptor of PSII; B, secondary quinone of PSII; PQ, plastoquinone; Cyt *f*, cytochrome *f*; PC, plastocyanin; P700, reaction center chlorophyll(s) of PSI; X, used here to include the numerous initial acceptors of PSI; fd, bound ferredoxin; NADP red, NADP reductase; CF and CF₀, the coupling factor complex. (b) Representation of the arrangement of electron transport components in the chromatophore membrane. The meaning of the symbols are as follows: Cyt *c*₂, cytochrome *c*₂; P870, reaction center bacteriochlorophyll dimer; UQ_I, ubiquinone I the so-called "primary" acceptor even though a bacteriopheophytin is the initial acceptor; Fe, iron atom; UQ_{II}, secondary ubiquinone of the reaction center; UQ, ubiquinone; Cyt *b*, cytochrome *b*; UQ_Z, another functionally distinct ubiquinone; NHI, non-heme iron-containing protein; F₁ and F₀, the coupling factor complex. UQ_I (Q) ≡ Q_A; UQ_{II} (B) ≡ Q_B.

date for the role of a proton pump. This may well be the case for mitochondrial cytochromes (Cyts) *b* (Papa, 1976) and for Cyt oxidase (Wikström, 1977). An analogous role has been suggested by Petty and Dutton (1976) for Cyt *b* ($E_{m7} = 50$ mV) in chromatophores of *Rhodospseudomonas* (*Rp.*) *sphaeroides*. This sort of indirect conformational coupling mechanism is not bound by a specific H^+/e^- ratio. In principle the ratio could be large and flexible, responding to ambient pH.

2. THE PROTON-TRANSLOCATING ATPase

All phosphorylating systems possess an enzyme complex capable of coupling the active translocation of protons and the synthesis of ATP (see McCarty, 1978; McCarty and Carmeli, Chapter 14, this volume). As data accumulate from different energy transducing systems (photosynthetic and respiratory), it has become apparent that the essential structural and functional features of these enzyme complexes have been maintained throughout evolution. Very briefly all ATPase complexes are formed by two functional parts: (a) one is an extrinsic oligomeric structure called F_1 (CF_1 in higher plant chloroplasts) that forms a spherical structure about 90–115 Å in diameter and faces the stroma in chloroplasts or the cytoplasm in bacteria; and (b) the second component is an intrinsic membrane complex called F_0 (CF_0 in chloroplasts). The F_0 functionally connects the extrinsic protein (F_1 or CF_1) with the coupling membrane. Since chapter 14 by McCarty and Carmeli in this volume will be devoted specifically to these proteins, only the points essential for bioenergetic considerations will be discussed here.

Originally Mitchell suggested that the reversible coupling of the H^+ transport with the ATPase results from the vectorial uptake of H^+ and OH^- from opposite sides of the membrane (see Fig. 3 in Mitchell, 1968). More recently he has proposed a mechanism involving electrophilic attack of high potential protons on the phosphate oxygen (Mitchell, 1977). In both cases the mechanisms adhere strictly to a stoichiometry of $2H^+/ATP$. However, since a stoichiometry of $2H^+/ATP$ seems to be in disagreement with much experimental data (see later), consideration of more flexible coupling mechanisms of the "conformational" type should perhaps be entertained.

The enzyme complex F_1 or CF_1 , when solubilized from the membrane, cannot catalyze any reactions related to the energy conserving or transducing processes ($ATP-P_i$ exchange or ATP synthesis). The free energy of ATP hydrolyzed by solubilized F_1 or CF_1 is totally and irreversibly dissipated as heat to the system. The sensitivity to specific inhibitors of phosphorylation, such as DCCD, Dio-9, and oligomycin, is lost when F_1 or CF_1 is solubilized. All of these properties are restored when the

soluble ATPase is induced to interact with the intrinsic part of the enzyme in the membrane.

It has been proposed that the F_0 portion of the complex constitutes a proton-conducting channel across the membrane, connecting the active sites of F_1 to the opposite face of the membrane. Indeed, many observations support this proposal. In chloroplasts the removal of CF_1 from the membrane greatly enhances the conductance of the membrane to protons (McCarty and Racker, 1967) and prevents the formation of an electric field (Schmidt and Junge, 1975). This seems not to be the case in chromatophores of *Rp. capsulata* (Melandri *et al.*, 1970). Low molecular weight hydrophobic proteins have been isolated from numerous sorts of energy-transducing membranes (e.g., Nelson *et al.*, 1977). These proteins promote proton conduction across liposomes and the promotion is reversed by binding of DCCD. This low molecular weight intrinsic membrane protein is a subunit of F_0 and it has been suggested that a hexameric aggregate (Sebald *et al.*, 1979) forms the proton-conducting channel.

If the transmembrane proton-conducting structure of CF_0 does not constitute any diffusion barrier to protons between CF_1 located at one end of the channel and the aqueous bulk phase at the opposite end of the channel, then a complete equilibration of the electrochemical potential of protons along the whole length of the channel must occur (Mitchell, 1976). In this situation the "proton well" formed by CF_0 should offer a hydrophilic phase of high electrochemical potential adjacent to the active site of the ATPase. If so, the entire Δp between bulk phases would be transformed into a working proton potential difference across the ATPase active site. According to this view, CF_0 has no catalytic role and the whole vectorial mechanism of catalysis is carried on by the CF_1 complex. Indeed observations by Bogustavsky *et al.* (1975) have demonstrated that solubilized F_1 from mitochondria can generate an electrostatic potential difference between two nonmiscible phases, an aqueous phase in which ATP hydrolysis takes place and a hydrophobic phase containing dinitrophenol as a proton acceptor. This ingenious experiment suggests that the F_1 complexes adopt a directional orientation in an amphipathic interface and impart a vectorial mechanism of proton translocation.

D. Differences between Chemiosmotic Coupling and Williams's Two-Phase Coupling Model

Williams's (1961, 1978a) views differ in many important ways from the chemiosmotic hypothesis. Williams proposes that a two-phase sys-

tem, rather than the three-phase system of chemiosmosis, is the minimum requirement for coupling two chemical events through high potential protons. These two phases can be represented very well by a membrane-water interface in which high energy protons generated by exergonic reactions can be retained in the membrane and delivered to drive a different endergonic transformation. Thus, in Williams's view it is the membrane itself that becomes the reservoir of high energy protons and provides, within its structure, the proton conducting link between intramembrane enzyme complexes. This idea is very different from chemiosmosis, in which proton currents necessarily flow through the bulk phase of an aqueous compartment. The two-phase model requires that the high energy protons in the membrane not be in equilibrium with those in a bulk aqueous phase. Thus, the membrane cannot be considered as simply an inert dielectric barrier, but rather constitutes a sophisticated network of proton conducting structure connecting functional intrinsic membrane proteins. The localization of protons within the membrane structure would have profound effects on the size of the energy-storing capacity, since it can be expected that such a localized energy transducer would not be able to accommodate in its "compartments" as many protons as a fully delocalized chemiosmotic system. Since capacitative parameters are decisive factors in establishing the kinetic behavior of a system during transients, the main differences between the two models possibly can be best evaluated in pre-steady state kinetic studies of energy transduction (e.g., kinetics of the formation of the proton gradient, induction of phosphorylation during a dark-light transition, and so on).

Williams (1978b) has proposed that a highly proton-conductive device within a membrane can be provided by the structured water present in the hydrophilic region of membrane proteins. Proton mobility along ordered water molecules can be much faster than in liquid bulk water and can therefore offer a kinetically preferential pathway to proton currents. The concept does not exclude the possibility of a slower equilibration of intramembrane and bulk protons. In this sense chemiosmosis can be considered as a limiting case of the model in which no diffusion control operates at the interface (Williams, 1978a), thus requiring a three-phase system in order to conserve energy as a proton electrochemical potential difference.

The nature of the kinetic barrier limiting proton exchange at the membrane-water interface has been discussed by Kell (1979). He suggests that the oriented water molecules of the Stern-Grahame layer, present on a negatively charged membrane surface exposed to a medium of relatively low ionic strength, offer the kinetically preferential

pathway to protonic currents. In our view, this suggestion offers the advantage of not requiring any special structural feature of the membrane architecture and of reconciling somewhat the fully delocalized scheme of chemiosmosis and the largely localized mechanism of Williams.

II. Structural Organization of Coupling Reactions and Components

It is not our purpose here to treat comprehensively the structural organization of the photosynthetic membranes of chloroplasts and bacteria; this is done by Kaplan and Arntzen, Chapter 3, in this volume. Here we will confine ourselves to a discussion of (1) the orientation of the charge-generating and proton-producing reactions within the membrane; (2) the spatial association of the coupling factor enzyme complex to the charge-generating and proton-producing reactions; and (3) the structural identification of the "phosphorylating unit."

A. Orientation of the Charge-Generating and Proton-Producing Reactions

The primary charge-generating process across photosynthetic membranes is the light-induced charge separation between the primary donor and primary acceptor of the reaction center complex. The spatial arrangement of the reaction center within the membranes is best characterized for the photosynthetic bacteria *Rp. sphaeroides* strain R-26. Feher's laboratory used a ferritin antibody procedure to examine the surface exposure of the reaction center polypeptides (Feher and Okamura, 1977). The reaction center complex is exposed at both membrane surfaces. See Okamura *et al.* (Chapter 5, this volume) for details of the membrane orientation of the three reaction center polypeptides. The primary donor, a bacteriochlorophyll dimer, is located near the inner surface of the chromatophore since the oxidized reaction center bacteriochlorophyll is re-reduced by electron transport from Cyt c_2 which is located within the chromatophore lumen (Prince *et al.*, 1975). It should be noted, however, that the reduction of the oxidized bacteriochlorophyll dimer by Cyt c_2 gives rise to carotenoid band shifts. This is an indication that the dimer is located some appreciable distance into the membrane. The so-called "primary" acceptor is a quinone lo-

cated near the outside of the chromatophore, where subsequent electron transfer to a second reaction center quinone results in proton binding on the outer surface (Petty and Dutton, 1976). Less detail is known about the reaction center complexes of higher plants. However, the general picture appears to be similar; the primary donor and primary acceptor are oriented so that charge separation occurs perpendicular to the plane of the membrane. Thus, in both chloroplasts and bacteria, the formation of the donor-acceptor ion pair will result in a transmembrane electric potential difference, the nature of which will be discussed in Section III of this chapter.

The electron transfer reactions coupled to the oxidation of the primary acceptor and reduction of the primary donor may also function as transmembrane charge-generating reactions. When the spatial arrangement of a particular sequence of redox components leads to transmembrane separation of a proton from its electron, an electrochemical potential can be established. Although there is still uncertainty regarding the exact pathway of electron transfer in *Rp. sphaeroides* chromatophores (see Cramer and Crofts, Chapter 9, this volume), it appears that the reduction of ferricytochrome c_2 at the inner membrane interface and reduction of ferricytochrome b_{50} near the inside of the membrane by hydroquinone species both result in proton release. Subsequent transport of the electron across the membrane completes the charge separation (e.g., Petty *et al.*, 1977).

In chloroplasts the reduction of the oxidized photosystem II (PSII) reaction center chlorophyll by electrons from water occurs near the inner surface of the lamellar membrane where protons are released (for a review, see Trebst, 1974). In addition, the oxidation of plastoquinone directly or indirectly by Cyt *f* located near the inner membrane surface results in proton release. (An iron-sulfur protein, analogous to the Rieske protein of the respiratory chain, may operate between these two carriers; see Malkin and Aparicio, 1975; Whitmarsh and Cramer, 1979a.) The result is that plastoquinone oxidation as well as water oxidation contribute to an electrochemical potential of protons.

B. Spatial Distribution of the Coupling Factor Enzyme Complex

The spatial proximity of the coupling factor enzyme complex to the components of the electron transfer chain is an important concern. Distance between the redox reactions and the ATP formation machinery

ated 20% at a titer of one valinomycin molecule per chromatophore. ATP formation was correspondingly diminished. From these experiments it was concluded by Witt and co-workers that the functional electrical unit and the phosphorylating unit are equivalent to a single "thylakoid disk" in chloroplasts and the chromatophore vesicle in bacteria. It is difficult to understand why the removal of individual electrical units from a population of independently functioning vesicles would result in a uniform increase in the decay of the electrical field in all of the vesicles. Rather, the expected effect of an ionophore should then be to induce a very rapidly decaying component of the electrochromic change in those chloroplasts or chromatophores containing antibiotic, and no change at all in the vesicles not containing antibiotic. In the limiting situation, where the ionophore-enhanced decay is too rapid to detect, there should simply be a reduction in the amplitude of the electrochromic change without any alteration of the kinetics. Moreover, the calculations made by Junge and Witt (1968) were based on an estimate of 10^5 molecules of chlorophyll per "thylakoid disk." More accurate estimates have been obtained which show that there are actually about 10^6 chlorophylls per "thylakoid disk" (R. J. Berzborn, personal communication, 1980). In addition, within a grana stack the lamellar membrane folds back on itself an average of four to five times forming an osmotic continuum equivalent to four or five "thylakoid disks" (Park and Sane, 1971; R. J. Berzborn, personal communication). In fact the entire lamellar system of a chloroplast may be composed of one or a few continuous sheets (Park and Sane, 1971). Thus it appears that at least 40–50 molecules of gramicidin per space were present. If so, it is then easy to understand the uniform increase in the decay of the electrochromic signal but, by the same token, no information about the size of the functional unit can be obtained from such data. For all these reasons, we feel that the widely quoted inhibition of phosphorylation by one molecule of antibiotic per vesicle should be heavily discounted.

There is a great deal more to be said about the identification of the phosphorylation unit but this will be deferred to later sections of this chapter where the mechanism of phosphorylation will be discussed in more detail.

III. The Transmembrane Electrochemical Hydrogen Ion Gradient

The measurement of the thermodynamic and kinetic parameters of the electrochemical gradient of protons is of paramount importance in a

quantitative study of the mechanism of photophosphorylation. The success of these measurements rely on (1) the availability of reliable methods for the evaluation of the electrostatic and chemical component of the Δp (Rottenberg, 1975); and (2) the availability of measurement techniques rapid enough to allow a kinetic study of the formation of the proton electrochemical potential difference. Many experimental techniques, both direct and indirect, have been proposed for the evaluation of the H^+ electrochemical potential or Δp , henceforth designated Δp . However, in our opinion the quantitative reliability of current methods is often compromised by arbitrary and difficult to test assumptions. For instance, ion distribution, utilized for the evaluation of the membrane potential, is usually considered as the standard by which other methods are judged (Michels and Konigs, 1978; Kell, 1979). However, the technique of measuring ion distribution is actually based on very rough approximations: (a) it utilizes equilibrium considerations when the steady state distribution of the indicator ion should be more correctly considered at static head; and (b) it derives the internal activity of the marker ion from a mass balance, implicitly assuming an internal activity coefficient equal to one and ignoring the possibilities of ion binding to the membrane or other kinds of complex formation. Thus the assumption ignores any interactions of the ions (whose internal concentrations can reach rather high values), which could alter the distribution ratio. A comprehensive and critical review of the methods for the evaluation of the H^+ concentration gradient (ΔpH) and the electrical potential gradient ($\Delta \psi$) components of Δp in photosynthetic membranes is beyond the scope of this chapter. Instead we will point out only the major areas of uncertainty in the experimental data cited.

A. *The Kinetics of Formation of
the Electrochemical Gradient of Protons and
Its Relationship to the Induction of Phosphorylation*

1. THE RATE OF FORMATION OF THE ELECTROCHEMICAL
GRADIENT OF PROTONS

a. Formation of the Electric Field. According to the chemiosmotic model, a transition of photosynthetically active membrane preparations from dark to light initiates a net flow of protons into the inner compartment of a membrane-enclosed vesicle and, at the same time, a charge-generating transfer of electrons across the membrane in the opposite direction. This electrogenic proton transport results in the formation of

an electrochemical potential difference of protons across the membrane, the sum of ΔpH and $\Delta\psi$, which in turn can drive an inverse flow of protons across the ATPase or through nonproductive proton leakage pathways. Additionally the electrochemical potential difference is said to exert a back pressure on the electron flow coupled to the proton pump (Mitchell, 1968). Eventually the back pressure will become large and balance the forward pressure exerted by proton-translocating electron transport in the condition we have called static head (Caplan and Essig, 1969; Rottenberg, 1979).

The amount of electron transport required to reach the static head condition depends on the electrical capacitance and proton binding capacity of the membrane. In general, since the electric capacitance of biological membranes is small (typically $1 \mu\text{F cm}^{-2}$) (Jain, 1972; Packham *et al.*, 1978), a small number of charges translocated is sufficient to generate large membrane potentials in small fractions of seconds (Jackson and Crofts, 1971; Rumberg, 1977). This rapidly formed electrical potential is transient and is quickly diminished by slower secondary electrophoretic ion fluxes. Meanwhile the ΔpH builds up more slowly as a result of these ion fluxes. The result is that the electrical potential component of Δp is gradually replaced by a pH difference. Thus the condition of static head for protons is reached only after relatively prolonged electron transport, since most of the protons must be taken up in exchange for other cations (in the chloroplast mostly Mg^{2+} and K^+) (Dilley and Vernon, 1965) or together with counterions (notably Cl^-) (Deamer and Packer, 1969; Rottenberg *et al.*, 1972) or both (Hind *et al.*, 1974) in the electroneutral fashion necessitated by the small capacitance of the membranes. On the other hand the Δp can reach near maximum values very rapidly because of this same low electrical capacitance of the membrane. Thus, after the onset of electron transport the two separate components of Δp are formed out of phase, $\Delta\psi$ governed by the particular capacitative parameters of the membrane (Melandri *et al.*, 1978a; Junge *et al.*, 1979) and the rate of formation of ΔpH being governed by the larger hydrogen ion buffering capacity.

The most accurate measurements of the rate of formation of the membrane potential in photosynthetic systems have been performed using the electrochromic response of endogenous pigments. Indeed, this is actually the only method with a response fast enough to be utilized for the study of phenomena coupled to the primary and secondary reactions of photosynthetic electron transport (for review, see Witt 1975; Packham *et al.*, 1978). In both chromatophores and chloroplasts the primary charge separation and the consequent formation of a fixed

dipole field in the membrane is a very fast event, practically coincident in time with the primary photochemical reactions (half-risetime $< 10^{-8}$ sec) (Wolff *et al.*, 1969). This dipole field should, in Mitchell's view, be very rapidly delocalized in comparison to the time scale of phosphorylation, to become effective chemiosmotically. The mechanism of delocalization is envisioned to include ionic redistribution at the membrane interface and the proton translocating reactions of secondary electron transport (Crofts *et al.*, 1971).

The electrogenic steps which can produce the membrane potential are varied. In chloroplasts the primary photoreactions of the two photosystems have been shown to contribute equally to the formation of the field (Schliephake *et al.*, 1968). In chromatophores the electrochromic signal is formed in three distinct kinetic phases (Jackson and Crofts, 1971), which have been assigned to the primary photoact, the reduction of the oxidized P870 by Cyt c_2 (Jackson and Dutton, 1973) and electron flow in the Cyt b -Cyt c_2 region of the electron transfer chain (Jackson and Crofts, 1971; Jackson and Dutton, 1973; Crofts *et al.*, 1975). Indications of a slow electrogenic event associated with secondary electron transport in chloroplasts have now been presented (Bouges-Bocquet, 1977; Velthuys, 1978).

These conclusions have been drawn mainly from single turnover experiments in which electron flow was activated by very short ($< 10 \mu\text{sec}$) xenon discharge lamp or laser flashes. If several turnovers of the photosystems are induced by longer illuminations or by trains of single turnover flashes, the electrochromic signal indicates that the field increases severalfold until it reaches a maximum after about five or six turnovers (Jackson, 1975). In continuous light, the electric field is initially large but decreases to about 1/20 of the maximum in chloroplasts (Rumberg, 1977) or about 1/2 of the maximum in chromatophores (Jackson and Crofts, 1971), and about 1/3 of the maximum in subchloroplast particles (Rottenberg, 1977). The decline of the field during prolonged illumination has been interpreted as a consequence of secondary ion transport (see earlier). The steady state extent of $\Delta\psi$ is therefore believed to be dependent on the intrinsic permeability properties of the membrane as well as on the ionic composition of the suspending medium.

A considerable uncertainty exists regarding the absolute values of the membrane potential. Several criteria have been utilized for quantitating the electrochemical signals. These include: calibration with diffusion potentials of permeant ions (usually K^+ -valinomycin), evaluation of capacitance and number of charges translocated per vesicle (Schliephake

et al., 1968; Packham *et al.*, 1978), and response to the potential-sensitive ionophore alamethacin (Zickler *et al.*, 1976; Packham *et al.*, 1978). We have tabulated values of the membrane potentials reported employing these various methods. These values should be compared with other measurements which utilize distribution of permeant ions or spectroscopic probes (see Table I). In general there is a large disagreement among the results obtained with these different approaches. It has been suggested that the endogenous pigments, being embedded in the membrane structure, sense the membrane potential at the interface (Rumberg, 1977; Matsuura *et al.*, 1979), whereas in ion distribution studies the electric potential difference of the two aqueous phases are measured. If so, when a potential difference exists between the aqueous phase and the membrane surfaces due to the electrostatic effects of fixed charges and if this difference is asymmetric on the two sides of the membrane (Rumberg, 1977; Witt, 1979), a difference between electrochromic and ion distribution measurements has to be expected. According to this interpretation the data in Table I would indicate that in continuous light, the potential difference across the chloroplast membrane (100 mV in *Chlorella*; Gräber and Witt, 1974) is due mainly to surface potential asymmetry. The discrepancy may be less important in chromatophores (Matsuura *et al.*, 1979; see, however, Ferguson *et al.*, 1979). Rumberg (1977) suggests that the main reason for surface potential asymmetry in continuous light is the electric neutralization of the negative groups on the membrane by binding of the protons translocated into the inner compartment. If this were so, however, proton uptake should result in an increase in the surface potential difference and consequently in the field sensed by the electrochromic pigments. This is contrary to the experimental observations; thus, one would have to conclude that the phenomenon is totally masked by the drop of $\Delta\psi$ resulting from secondary ion movement and by the decrease of the internal pH.

b. Formation of the pH Difference. The formation of the pH difference across the photosynthetic membrane is a slow process when compared to membrane potential development (Melandri *et al.*, 1978a; Witt, 1971). This is due mainly to the presence of endogenous hydrogen ion buffering groups in the inner compartment whose average pK_a is probably about 4.3 (Nakatani *et al.*, 1978) in chloroplasts and probably about 5.0 in chromatophores (Matsuura *et al.*, 1979). Moreover, the rate of entry of protons is almost immediately controlled by the rate of secondary ion transport. By measuring the inner thylakoid pH with the pH indicator neutral red, Junge and Ausländer (1973) have estimated that

TABLE I
Measured Values for the Proton Motive Force (mV) in Continuous Light

System	Method	-60 ΔpH	Δψ	Δp	Reference
Chloroplasts	9AA ^a quenching	210-240			Pick <i>et al.</i> (1974)
	⁸⁶ Rb, ³⁶ Cl distribution		0	210-240	Schuldiner <i>et al.</i> (1972a)
	[¹⁴ C]hexylamine distribution rate of electron transport	192 180	—	—	Rottenberg <i>et al.</i> (1972) Portis and McCarty (1974) Rumberg and Siggel (1969)
Subchloroplast	electrochromism		30-100		Witt (1971)
	9AA ^a quenching	156		216	Rottenberg and Grunwald (1972)
Chromatophores	¹⁵¹ I distribution		60		Rottenberg (1977)
	[¹⁴ C]methylamine distribution	105		195	Schuldiner <i>et al.</i> (1974)
<i>Rs. rubrum</i>	CS ¹⁴ CN - distribution		90		
	9AA ^a quenching	148		258	Leiser and Gromel-Elhanan (1977)
<i>Rp. capsulata</i>	ANS ^b fluorescence		110		
	9AA ^a quenching	115		305	Casadio <i>et al.</i> (1974b)
<i>Rp. sphaeroides</i> (Cl - absent)	electrochromism		190		Melandri <i>et al.</i> (1978b)
	[¹⁴ C]methylamine distribution	85		385	Ferguson <i>et al.</i> (1979)
<i>Rp. sphaeroides</i> (Cl - absent)	electrochromism		300		
	[¹⁴ C]methylamine distribution	85		225	Ferguson <i>et al.</i> (1979)
<i>Rp. sphaeroides</i> (Cl - absent)	S ¹⁴ CN -		140		
	[¹⁴ C]methylamine distribution	81		128	Mitchels and Konigs (1978)
	S ¹⁴ CN -		47		

^aAA refers to 1-Aminoacridine.

^bANS refers to 1-Anilino-naphthalene-8-sulfonate.

in spinach chloroplasts the drop in pH per turnover is about 0.05 units (about 20 turnovers per pH unit of ~ 60 nEq protons mg Chl $^{-1}$) (Junge *et al.*, 1979) whereas Tiemann *et al.* (1979) arrived at a value of 0.2 pH units \cdot flash $^{-1}$. Measurements in *Rp. capsulata* chromatophores reveal that the endogenous buffering capacity corresponds to about 8–14 turnovers per pH unit (Melandri *et al.*, 1978a). The large difference in the rate of formation of $\Delta\psi$ and ΔpH has a profound bearing on the composition of the Δp which, as we have already pointed out, is largely electrostatic during the first turnovers of the photosynthetic electron flow and becomes more and more dependent on ΔpH the longer the illumination time. This behavior is particularly important in chloroplasts where, according to most observations, the electrostatic component nearly vanishes in continuous light.

The hydrogen ion buffering capacity of the internal aqueous phase can be greatly augmented by permeant weak amines. These substances (Crofts, 1968; Avron, 1972) increase the extent of the proton accumulation, indicating that the static head condition for proton flux is controlled by the activity of the protons in the internal bulk phase. Permeant exogenous buffers may therefore be important tools for the study of transient events of photophosphorylation since they can delay markedly the generation of a pH difference across the membrane (Ort *et al.*, 1976).

2. INDUCTION PHENOMENA IN ATP SYNTHESIS

If we assume for the moment an absence of activation processes, such as an activation of the coupling factor, then according to the chemiosmotic hypothesis the onset of photophosphorylation after the beginning of illumination should be strictly correlated with the rate of formation of the transmembrane Δp . An experimental verification of this prediction is difficult to carry out due to the slow response of the many techniques used to evaluate $\Delta\psi$ and ΔpH and to the uncertainty of the quantitative calibration of these methods. Only the rapidly responding electrochromic shift of endogenous pigments seems fast enough for these sorts of experiments. Also critical for these studies is the ability to detect very small amounts of ATP synthesized as a consequence of short pulses of illumination. A procedure has been developed employing the luciferase enzyme which is sensitive enough to allow measurements of the ATP formed from single turnover flashes in bacterial systems (Lundin *et al.*, 1977). Similar sensitivity can be attained using procedures developed for isolating newly synthesized [γ - ^{32}P]ATP (Smith *et al.*, 1976).

Earlier studies of "presteady state" photophosphorylation by Junge *et al.* (1970) suggested that small amounts of ATP can be formed by chlo-

roplasts following a series of only 4–5 brief flashes. Analogous results were reported by Keister and Minton (1969) for *Rs. rubrum* chromatophores. Keister and Minton were unable to detect any lag in the onset of ATP synthesis when the time of illumination was extrapolated to zero.

A more systematic study of these phenomena in chloroplasts has been undertaken by Ort and colleagues (Ort and Dilley, 1976; Ort *et al.*, 1976), who examined the extent of phosphorylation induced by short flashes of variable duration. The precision of the experiment was improved by accumulating ATP from 20 to 60 flashes. The flashes were spaced 20 sec apart to allow dark readaptation of the system. (The multiple flashes were necessary because [γ - ^{32}P]ATP was assayed by the standard technique of extraction of unreacted $^{32}\text{P}_i$ as phosphomolybdic acid into organic solvent; this technique is not sensitive enough for determination of the ATP yield of very brief single flashes.) The experiments indicated that photophosphorylation begins at full rate within a very few milli-seconds after the beginning of illumination. It was also demonstrated that addition of valinomycin plus K^+ , a condition that prevents the rapid formation of $\Delta\psi$ by inducing a compensating cation flow out of the thylakoid inner compartment, significantly extended the lag (to about 50–60 msec). Similar effects of valinomycin were demonstrated in *Rp. capsulata* chromatophores by Melandri *et al.* (1978b). In the absence of ionophores to promote rapid charge neutralizing ion movements, no detectable lag was observed following millisecond-long flashes in chromatophores. Employing the very sensitive assay for newly synthesized [γ - ^{32}P]ATP mentioned earlier (Smith *et al.*, 1976), Vinkler *et al.* (1978, 1980) demonstrated that the onset of ATP formation is coincident with the onset of illumination on a millisecond time scale. Measurements by Graan and Ort (1981) have corroborated these data.

These results are qualitatively in agreement with the concept discussed in the preceding section: that is, the electrostatic component of the Δp forms very rapidly in photosynthetic membranes, much more so than the chemical component and, during this initial phase, ATP synthesis is very sensitive to the potential-destroying valinomycin-facilitated K^+ flux. A more quantitative analysis has been achieved by Melandri *et al.* (1980) by carefully controlling the thermodynamic quantities involved in the process of energy transduction. Photophosphorylation by chromatophores induced by single turnover flashes was studied under carefully controlled values of ΔG_{ATP} . It was shown that an induction lag can indeed be demonstrated in chromatophores in the absence of K^+ -valinomycin although in normal phosphorylation conditions (i.e., low ΔG_{ATP}), the lag can be as short as one single turnover (the amount of

ATP formed during the first single turnover flash can be up to 50% of the maximum yield per flash). The lag is increased markedly (up to 3 to 4 turnovers) when the ΔG_{ATP} is elevated by exogenous ATP. This observation is in accord with energetic considerations since the energetic threshold for ATP synthesis should be dependent on the value of ΔG_{ATP} . Addition of K^+ -valinomycin increased the lag to more than 20 turnovers.

It is expected, from considerations of the chemiosmotic hypothesis, that once the electrical component of the Δp has been abolished by valinomycin-facilitated K^+ movement, the onset of photophosphorylation should depend on the development of the transmembrane pH difference. The number of protons required to establish a sufficiently large pH difference between the inner and outer aqueous phases is unavoidably a function of the buffering capacity of the inner compartment. An increase in internal buffering will delay the formation of the ΔpH and, according to the chemiosmotic hypothesis, this delay should be reflected in the induction of photophosphorylation. Ort *et al.* (1976) measured the amount of permeant buffer, such as tris(hydroxymethyl)aminomethane, or bicarbonate, that was present in the thylakoid inner compartment. Despite increases in the buffering capacity of the inner compartment due to the presence of such permeant buffers that would require several hundred milliseconds of additional electron transport driven proton accumulation to titrate, no significant increase in the duration of the phosphorylation lag was detected. On the other hand, basic amines such as methylamine, that uncouple but do not buffer appreciably in the physiological pH range, increased the phosphorylation lag significantly (Ort, 1978). These data led to the conclusion that the pH of the inner aqueous bulk phase of the thylakoids was probably of only secondary importance to the energization of photophosphorylation. Instead Ort (1978) argued for a kinetically favored pathway for protons from the proton-producing reactions to the coupling factor which did not include the bulk inner phase as an obligate intermediate. The major uncertainty in these studies stems from the procedure of using multiple flashes to accumulate sufficient ATP to measure reliably. Davenport and McCarty (1980) chose to accept a low signal-to-noise ratio in an effort to look at the effect of internal buffering after only a single flash. They feared that the failure of Ort *et al.* to observe a delay induced by the exogenous permeant buffers might be due to an incomplete relaxation of the pH difference in the time allowed between events. In their experiments using single flashes, they found that 2 mM imidazole actually delayed the onset of phosphorylation for about 1 sec. However, this concentration of imidazole gave 70% inhibition of phosphorylation by uncoupling,

a condition already known to induce lags. These observations are at variance with the findings of Ort *et al.* (1978) who observed almost no lag due to much higher levels of buffering by tris(hydroxymethyl)aminomethane when single flashes were used. Thus, the difference in results may be simply the result of imidazole uncoupling since tris(hydroxymethyl)aminomethane uncouples hardly at all.

The two sets of results clearly cannot be accommodated by a compromise interpretation. The concern that protons may be accumulating during repeating flashes is important and requires that a sensitive ATP assay be applied so that the products of single flashes can be reliably measured. Moreover it is essential that the hydrogen ion buffers used to stabilize the pH of the internal compartment not also be uncouplers (a property shared by all of the permeant amine buffers of appropriate pK_a). Vinkler *et al.* (1978) have applied a sensitive ATP assay to these studies. S. Flores and D. Ort (unpublished results) have measured the movement of hydrogen buffers such as Tricine and MOPS, which move across the chloroplasts membrane, albeit slowly, and these compounds do not uncouple. Thus a resolution to the disagreement seems at hand.

B. Photophosphorylation in Steady State Conditions

According to the chemiosmotic model, the rate of steady state phosphorylation should also correlate with the size of the Δp across the membrane. Studies of this aspect of photophosphorylation are numerous since no experimental limit is imposed on the response time of the methods to be utilized.

In chloroplasts a linear correlation between ΔpH and the rate of ATP synthesis has been reported utilizing either amine distribution (Portis and McCarty, 1974, 1976) or the 9-aminoacridine fluorescence quenching (Pick *et al.*, 1975) for the evaluation of ΔpH . Since these measurements were performed in continuous light when the membrane potential is probably negligible, this empirical correlation can be taken as evidence of a relationship between Δp and rate of phosphorylation.

The maximal amount of chemical work performed during phosphorylation has been evaluated measuring the maximal ATP/ADP ratios maintained in continuous light by photosynthetic membranes. When this upper limit is reached the net rate of phosphorylation vanishes and the rate of electron flow decreases (Kraayenhof, 1969). This condition has been termed the *static head* for ATP synthesis. The maintenance of the static head condition requires energy input and is provided by the basal electron flow. In chemiosmotic terms the maximal output force in this state, $\Delta G_{ATP, \max}$, should be uniquely related to the extent of Δp , the

degree of coupling of the ATP synthetase, and the H^+ /ATP stoichiometry of this enzyme. The maximal ΔG_{ATP} value measured in chloroplasts was reported by Kraayenhof (1969) to be about 15.5 kcal/mole. This value was revised downward to 13.5 kcal/mole when a more recent value for the standard free energy of hydrolysis of ATP was used (Rosing and Slater, 1972). In chromatophores values of 15.5 kcal/mole have been measured (Leiser and Gromet-Elhanan, 1977; Casadio *et al.*, 1978). This value decreases when Δp is lowered by uncouplers or when $\Delta\psi$ or ΔpH are specifically inhibited by specific ionophores. Similar values were obtained from measurements of ATP hydrolysis when the static head condition was obtained by poisoning the ΔG_{ATP} at high values. These observations are a clear indication of the reversibility of the catalytic mechanism of ATP synthetase (Casadio *et al.*, 1978).

The energetic equivalence of ΔpH and of $\Delta\psi$ in driving phosphorylation was suggested by the stimulatory effect of K^+ diffusion potentials on the rate of ATP synthesis when a suboptimal steady state ΔpH was obtained with attenuated actinic light (Schuldiner *et al.*, 1972b; Uribe, 1972). The same conclusions were drawn by Gräber and Witt (1976), who exploited the largely different relaxation times of $\Delta\psi$ and ΔpH for establishing different values of these two components of Δp in chloroplasts subjected to flashing light excitation. With this approach the different response of steady state phosphorylation to $\Delta\psi$ (at constant ΔpH) and to ΔpH (at constant $\Delta\psi$) could be studied, and the two parameters seemed to be both energetically and kinetically equivalent. In all these studies a clear lower limit of ΔpH around 2.0–2.2 units was observed (to which a membrane potential of 20–50 mV should be added) (Uribe, 1972; Portis and McCarty, 1974; Pick *et al.*, 1975), below which no net rate of ATP synthesis could be observed. This value, corresponding to a Δp of 140–180 mV, imposes an important thermodynamic restraint on the minimum value of the H^+ /ATP ratio.

In bacterial chromatophores the study of the correlation between Δp and phosphorylation is more complex, since under no circumstances (other than in presteady state conditions or in the presence of uncoupling ionophores) (Jackson *et al.*, 1968; Casadio *et al.*, 1974a) is the Δp formed by only ΔpH or by only $\Delta\psi$. The linear correlation between rate of phosphorylation and Δp was nevertheless confirmed in *Rp capsulata* chromatophores (Baccarini-Melandri *et al.*, 1977), combining measurements of the electrochromic shift of carotenoids and 9-aminoacridine fluorescence quenching. An energetic threshold of about 130–180 mV was observed in good quantitative agreement with that observed in chloroplasts. Nevertheless, these results need to be confirmed by alternate

methods because of uncertainties in the quantitative estimates of Δp by the methods available.

The chemiosmotic mechanism demands that the rate of ATP synthesis be only indirectly dependent on the rate of photosynthetic redox reactions (see Section I,B) and be controlled directly by the values of Δp and ΔG_{ATP} . Chloroplasts seemed to fulfill this requirement, since the same linear dependence of the rate of phosphorylation on $\Delta p\text{H}$ was found when the static head value of the $\Delta p\text{H}$ was decreased either with uncoupler (CCCP) or by attenuating the intensity of the actinic light (Portis and McCarty, 1974). Quite unexpectedly, however, this prediction could not be verified in chromatophores of *Rp. capsulata* in which a decreased rate of electron flow was accompanied by a parallel decrease in the rate of ATP synthesis but not by an accordant drop in the value of Δp (Baccarini-Melandri *et al.*, 1977; Casidio *et al.*, 1978). This important anomaly will be discussed later.

The rate of phosphorylation clearly must depend on Δp in some way and conversely one might expect that the extent of Δp would depend in some way on phosphorylation activity. Demonstration of an effect of phosphorylation on $\Delta p\text{H}$ in chromatophores has been frustrated by the complex modulation of proton permeability of the membrane by compounds such as P_i (Baccarini-Melandri *et al.*, 1975), adenosine nucleotides, and free Mg^{2+} (Gepshtein and Carmeli, 1974; Webster and Jackson, 1978). The effect of phosphorylation on the extent of $\Delta p\text{H}$ in chloroplasts is discussed in Section IV,A,1. In chloroplasts a strong acceleration of the decay of the electrochromic absorption change is observed in the presence of ADP and phosphate (Rumberg and Siggel, 1968; Junge *et al.*, 1970). The acceleration is inhibited by phlorizin or other energy transfer inhibitors (for a description of uncouplers and inhibitors, see McCarty, 1980). The decay of the electrochromic change is biphasic under phosphorylating conditions whereas the decay kinetics in the absence of phosphorylation are essentially first order. It has been proposed that the membrane potential controls the activation of the ATP synthetase (Junge, 1970), but it is now clear that ATP synthesis can occur when no electrochromic change has been allowed to take place (Graan and Ort, 1981). Unexpectedly in bacterial chromatophores, only a very small fraction of the decay of the carotenoid signal is accelerated by the addition of phosphorylation substrates (Saphon *et al.*, 1975b). This is not due to insufficient energization of the membrane since the percentage of accelerated decay is independent of the absolute extent of the signal (Saphon *et al.*, 1975b). The acceleration is apparently due to the catalytic activity of ATP synthetase since it exhibits a similar specifi-

city to nucleotide, the same apparent K_m for ADP, and the same response to inhibitors as phosphorylation or ATPase activity (Petty and Jackson, 1979a). The acceleration is moreover dependent on the presence of bacterial F_1 on the membrane. The small fraction of the electrochromic signal accelerated by ATP synthesis is perhaps another aspect of the behavior of chromatophores not entirely consistent with a minimal model of chemiosmotic coupling (also see the discussion of this phenomena in Section IV,B,2).

C. ATP Formed by Artificial Ion Gradients

Direct and convincing evidence for coupling between the flow of protons from the chloroplast inner compartment to the synthesis of ATP comes from the classic "acid-base" experiments of Jagendorf and Uribe (1966), demonstrating that phosphorylation can be driven by a proton concentration difference imposed across the membrane. These observations have been subsequently confirmed in bacterial chromatophores of *Rs. rubrum* (Gromet-Elhanan and Leiser, 1975; Leiser and Gromet-Elhanan, 1975), for which essentially the same characteristics have been demonstrated. The sensitivity of acid-base transition-induced ATP synthesis to inhibitors of ATPase and to uncouplers, as well as the lack of response to inhibitors of electron flow, suggested that this phosphorylation is catalyzed exclusively by the ATP synthetase and does not involve the redox reactions of the electron transport system. The role of the electrochemical activity of internal bulk protons in driving the reaction is supported by the very large stimulatory effect that permeant buffers (of $pK_a \sim 5-5.5$) have on the amount of ATP synthesized (Nelson *et al.*, 1971; Avron, 1972). Similarly, permeant buffers delay the light-induced buildup of the capacity of chloroplasts to make ATP in the dark (Ort *et al.*, 1976; Vinkler *et al.*, 1978).

Although ATP synthesis in post-illumination periods is driven mainly by ΔpH , since $\Delta\psi$ relaxes very rapidly in the dark, the interchangeability of $\Delta\psi$ and ΔpH in acid-base and post-illumination ATP synthesis has been indicated by the demonstration that phosphorylation can be induced or at least stimulated by diffusion potentials of other ions (positive inside) (Uribe, 1972; Gromet-Elhanan and Leiser, 1975). Phosphorylation induced by an applied electrical force has been demonstrated by Witt's group. They showed that chloroplasts can form ATP following a pulse of an external electric field across a chloroplast suspension (Witt *et al.*, 1976, 1977). It has been proposed that this activity is actually due to the electric field promoted by electrostatic induction across the membrane. Since the direction of this field is always parallel to that of the

external field and therefore opposite in the two halves of the membrane spheres, the actual possibility of inducing a useful $\Delta\psi$, stable long enough to allow the activity of ATP synthetase, is dependent on the rotation time of the vesicle and on the mobility of the ions present in the suspending medium (Witt and Zickler, 1973).

Quantitative calculations on the relationship between the externally induced electric field and the amount of ATP formed are uncertain since they involve the electrodynamic properties of the vesicles. It has been calculated that with an external pulse ranging between 200 and 1000 $V\text{ cm}^{-1}$, a membrane potential of some 100–200 mV (Gräber *et al.*, 1977) can be formed. This value is in agreement with the energetic threshold evaluated for Δp in light-induced phosphorylation. The apparent rate of ATP synthesis in the pulsed electric field compares favorably with that of photophosphorylation but the number of turnovers of the ATP synthetase per pulse is not known. An evaluation of this important parameter, which is relevant for the study of the kinetic properties of this enzyme, has been attempted by Gräber *et al.* (1977) who compared the amount of bound adenine nucleotides released per pulse (a parameter believed to be related to the number of ATP synthetase molecules activated by the field) (Strotmann *et al.*, 1976; see also Harris and Crofts, 1978) and the number of molecules of ATP formed (Gräber *et al.*, 1977). By studying the bound nucleotides released per pulse they concluded that about six turnovers per pulse took place. Furthermore it was also concluded that the increase of the ATP yield per pulse with increasing field strength was due to the increase in the number of activated ATP synthetases and not to a change in the turnover time of the enzyme.

D. Delocalization of Coupling

Another fundamental characteristic of the original, minimal chemiosmotic model is the rapid electrostatic and chemical equilibration of the protons translocated by the various proton pumps at the membrane interfaces into the bulk water phases. Only when this equilibration is rapid enough to approach an equilibrium situation is it correct to equate the electrochemical activities of bulk protons with the thermodynamic forces of the redox reactions and of the ATP synthetase. The establishment of criteria for the experimental test of this crucial point is difficult since the kinetic phenomena at the interfaces of biological membranes are difficult to evaluate utilizing macroscopic techniques. Probably the most reliable method that can give information on rapidly occurring phenomena in this microenvironment (since it avoids interference of

perturbing exogenous probe molecules) is the utilization of the electrochromic band shifts of endogenous pigments. Very rapid delocalization (in the millisecond time range) of the dipole field, generated by the primary photochemical reactions, has been inferred from the observation that the electrochromic signals are sensitive to ionophores at concentrations that are low enough to indicate that the field must be a collective property of a whole membrane vesicle (Boeck and Witt, 1972; Saphon *et al.*, 1975a). However, as we have already pointed out in Section II,C, these conclusions probably should be reconsidered since the calculations do not seem to be firmly based. Analogous conclusions (based on observations in the microsecond time range) were derived from the comparison of the decay kinetics of P700 photo-oxidation and of the electrochromic signals (Junge, 1975), as well as from kinetic evaluation of phenomena due to externally applied electrical potentials in chloroplast suspension (Witt and Zickler, 1973; Fowler and Kok, 1974). It must be remembered, however, that electrochromic signals are pertinent to electric phenomena occurring at the interface and do not necessarily report information on bulk phases, since a large capacitative barrier can exist at the bulk-interface boundary. If the inner bulk compartment is indeed the phase in which the high potential protons driving ATP synthesis are localized, then this should be reflected in a complete delocalization throughout the entire membrane-enclosed vesicle.

Measurement of the kinetics of appearance of protons in the thylakoid inner compartment would be of interest because it would provide information on the kinetic competence of the inner bulk phase as an intermediate between the redox reactions and the coupling factor-enzyme complex. The lipophilic pH indicator neutral-red has been used in an attempt to measure pH changes within the inner space when the pH of the external phase has been stabilized with bovine serum albumin. From these experiments a rate of acidification of the inner compartment following short xenon discharge lamp flashes has been reported to be as rapid as 100 μ sec (Junge *et al.*, 1978). Unfortunately, interpretation of the flash-induced neutral-red absorbance changes is not unequivocal. According to Pick and Avron (1976), a large part of the light-induced absorption changes in steady state measurements was due to binding of the indicator to the membrane. Hope and Moreland (1979) estimated the partition coefficient of neutral-red into chloroplast membranes to be about 2000. If so, there is an enormous reservoir of neutral-red in the membranes. Subsequently, Junge *et al.* (1979) extended their earlier studies with neutral-red and concluded that although bound to membrane, neutral-red still reported pH changes in the inner compartment. This conclusion was based principally on the proportionality of the neu-

tral-red signal and the calculated buffering capacity of the inner compartment which was manipulated by a wide range of exogenous buffers. The correspondence between the neutral-red absorption change and the buffering capacity, calculated assuming complete equilibration of the exogenous buffer, was generally very good. The remarkable feature of the data is that the maximal effect of the added buffers on the neutral-red signal was attained within 1 min. Thus, in order for charged compounds such as tricine, MOPS, HEPES, and so forth to prevent an absorption change of neutral-red reporting internal pH, it would be required that these compounds equilibrate in 1 min. A straightforward measurement of the entry of [^{14}C]-tricine into the inner compartment was made by standard techniques of centrifugal filtration. Under similar conditions to those used by Junge *et al.* (1979), the $t_{1/2}$ for tricine and MOPS entry was more than 20 min and equilibration was not approached for more than 1 hour (S. Flores and D. Ort, unpublished observations). Similar slow entry would be expected for many of the other charged buffers. These comparisons suggest that the chloroplast preparations used by Junge *et al.* (1979) were singularly "leaky." If so, this raises the questions as to whether the appearance of protons in the inner aqueous compartment in such "leaky" preparations is relevant to the phosphorylation phenomenon observed in more intact thylakoid membrane preparations.

Information concerning the interaction of bulk protons and ATP synthetase is scant. As mentioned earlier, the detachment of CF_1 from chloroplasts with 0.2 mM EDTA increases the ion conductivity of the membrane by two orders of magnitude (Schmidt and Junge, 1975). O'Keefe and Dilley (1977) showed that the increased conductivity resulting from CF_1 removal was due largely to enhanced hydrogen ion movement. The number of channels opened in the membrane by this treatment is difficult to evaluate, however, and no reliable conductance of the proton channels can therefore be inferred. The specific conductance of $6\text{H}^+/\text{sec}/\text{F}_0$ molecule (Okamoto *et al.*, 1977) which was reported for proteoliposomes in which proton permeability was mediated by F_0 of thermophilic bacterium PS3 (TF_0), seems much too low to account for a rapid equilibration of protons across the ATP synthetase active site [as compared for instance to the conductivity of a squid axon Na^+ channel about 10^6 ions sec^{-1} (Armstrong, 1975) or to the turnover of valinomycin about 10^4 ions sec^{-1} (Läuger, 1972)].

The agreement between the chemiosmotic model and the experimental results are not entirely satisfying. We have already pointed out that the most apparent discrepancies were uncovered in experiments probing the presteady state. In chloroplasts the buffering of the inner phase

with permeant agents did not cause a large delay in the onset of a full rate of photophosphorylation under conditions in which the fast formation of a large delocalized membrane potential was prevented (Ort *et al.*, 1976). We have already discussed the possible difficulties with these experiments (Section III,A,1,b).

Severe disagreement was observed when the rate of phosphorylation and the extent of transmembrane Δp were compared in chromatophores in which electron flux was inhibited by antimycin or limited by low light intensity versus partially uncoupled chromatophores (Baccarini-Melandri *et al.*, 1977; Casadio *et al.*, 1978). For the same rate of phosphorylation these authors observed dramatically different Δp values. This disagreement, clearly conflicting with a basic postulate of the chemiosmotic mechanism, was considered evidence of a more direct coupling between electron flow and the ATP synthetase. Although the techniques utilized to measure Δp have been challenged for being quantitatively in error (Michels and Konigs, 1978; Ferguson *et al.*, 1979), the difference in behavior of the rate of ATP synthesis and of Δp in uncoupled and electron transport-inhibited chromatophores would seem to be too striking to be explained on the basis of quantitative inaccuracy alone; the inaccuracy in any case should introduce the same systematic errors in the very different measured Δp values.

In some respects chromatophores and chloroplasts behave differently in the presteady state. The amount of the flash-induced electrochromic field decay accelerated by phosphorylation is very large in chloroplasts (up to 70% of the total signal) (Junge *et al.*, 1970), but is only 10–20% in chromatophores (Saphon *et al.*, 1975b; Petty and Jackson, 1979a). This latter observation is obviously not related to the size of the $\Delta\psi$ induced by a flash (Saphon *et al.*, 1975b). A clear correlation between the amount of ATP per flash and the membrane potential has been documented. It was demonstrated, however, that a large membrane potential can be reasonably stable in time ($t_{1/2}$ of decay \sim 5sec) but can contribute energetically to phosphorylation only following a new turnover of electron flow (Melandri *et al.*, 1980). Again this observation suggests that somehow redox reactions are more directly involved in the formation of ATP than is allowed by a minimal chemiosmotic model. This conclusion is also supported by the rather precise linear correlation found in *Rs. rubrum* chromatophores between the amount of ATP formed in pulsed light or in an isolated flash, and the amount of Cyt c_2 present in the preparation (Del Valle-Tascon *et al.*, 1978).

A molecular explanation of this apparently direct coupling between electron transfer and phosphorylation, especially evident in bacterial chromatophores (but also detected in many respiratory systems), is diffi-

cult to formalize. In the authors' opinion the evidence in favor of a basically chemiosmotic mechanism is too strong to allow the hypothesis of a direct molecular coupling of these two types of reactions (Boyer *et al.*, 1977). Perhaps the most likely explanation resides in the electrodynamic properties of the membranes and in local disequilibrium situations in microenvironments at the water-membrane interface. As mentioned earlier, the "electrodeic" model of Kell (1979) has drawn attention to the electrodynamic phenomena occurring at the membrane surface and to the relevance that oriented water molecules could have in the formation of a large capacitative barrier between the surface water and the bulk water. This situation would create conditions in which localized proton currents along the membrane surface would be privileged compared to those in bulk water. Since the stability of the oriented water layer is correlated to the intrinsic electric charge density of the membrane and to external parameters such as the presence of disorganizing ions in the suspending solution [notably ions such as SCN^- or K^+ -valinomycin (Kell, 1979), so often used in bioenergetic studies], the relative importance of these localized phenomena could be variable in different systems or in different experimental situations. This may possibly explain the different behavior between chloroplasts and chromatophores.

IV. Stoichiometries of Photosynthetic Energy Conversion

Fundamental to the mechanism of any chemical process is the exact quantitative relationship between reactants and products. The determination of these reaction stoichiometries can be straightforward and precise. Often these values are the earliest obtained and among the most significant data in establishing the molecular mechanism of a reaction. Reaction stoichiometries for the processes involved in energy transduction by photosynthetic membranes are still uncertain 28 years after photophosphorylation was first observed (Arnon *et al.*, 1954; Frenkel, 1954). The values have remained elusive for two central reasons: Some of the reaction participants are technically difficult to measure and, more importantly, the processes of electron transport and phosphorylation are only partially coupled. The chemiosmotic model defines a relationship between the basic stoichiometries (i.e., H^+/ATP of the ATP synthesizing enzyme, the H^+/e^- of the electron transport proton pump, and the $\text{ATP}/2e^-$) in such a way that the knowledge of any two allows computation of the third. The experimentally obtained values are of limited use

unless an accounting can be made for the exact degree of coupling between hydrogen ion movements that dissipate the transmembrane electrochemical gradient of hydrogen ions and hydrogen ion movements which result in energy storage by ATP synthesis. This section will deal very little with a cataloging of experimentally determined ratios in order to concentrate on the attempts that have been made to deal with the degree of coupling.

A. Chloroplast Stoichiometries

1. ATP/2e⁻

It is *not* experimentally difficult to measure precisely the amount of ATP formed in association with a given electron flux. In the recent literature there is general agreement that the experimentally obtained ATP/2e⁻ ratio for the linear transport chain falls in the range of 1.1–1.3 (e.g., Winget *et al.*, 1965; Ort and Izawa, 1973; Portis and McCarty, 1976; Wax and Lockau, 1980). Hall's group (Reeves and Hall, 1973; also see Robinson and Wiskich, 1976) has reported values of about 1.7 but the experimental conditions needed to attain these high ratios remain unclear and they have not been widely confirmed. There are two segments of the linear electron transport chain where an electron flux can support ATP formation (Izawa *et al.*, 1973; Trebst and Reimer, 1973). One segment is associated with the oxidizing side of PSII (Izawa and Ort, 1974) and operates *in vitro* with an ATP/2e⁻ ratio of about 0.4 (Izawa *et al.*, 1973; Trebst and Reimer, 1973). The other is probably identical to that identified by Avron and Chance (1967) between plastoquinone and Cyt *f* and operates *in vitro* with an ATP/2e⁻ ratio of about 0.6 (Izawa and Ort, 1974; Izawa and Pan, 1978).

An appreciable level of electron transport occurs in isolated chloroplasts in the absence of phosphorylation, the so-called "basal" electron flow. The fact that electron transport can occur without phosphorylation implies that the two processes are not entirely coupled as we have already mentioned. If so, ATP/2e⁻ ratios computed from the total electron flux, as is the case in those cited earlier, would yield values lower than the "true" stoichiometry of the process, unless phosphorylating electron transport somehow were to completely abolish the "basal" flow. There have been surprisingly few attempts to assess the relative contributions of basal and coupled electron transport occurring coincident with phosphorylation. The rate of electron flow through the entire electron transport chain is markedly stimulated by conditions that allow ATP formation to occur (i.e., the rate of basal electron flow is slower

than phosphorylating electron flow). Izawa and Good (1968) have shown that as long as the rate of electron flow is saturated by both light and the level of the electron acceptor, there is a mole for mole relationship between the ATP formed and the additional electron flux that occurs in response to ATP formation. They report that the relationship is precise and holds not only under conditions for optimal rates of ATP formation but also when the phosphorylation rate is varied over a wide range by limiting phosphate levels, by adding the uncoupler CCCP, or by adding the energy transfer inhibitors antimycin, PCMB, phlorizin, and 4'-deoxyphlorizin (Winget *et al.*, 1969). The interpretation of these data by Izawa and Good is straightforward. Under conditions where the electron transport carriers supplying the phosphorylating and non-phosphorylating (basal) pathways are saturated, the two pathways do not compete. That is, the phosphorylating electron flow is superimposed upon an unaltered basal electron flow. It then follows that the true stoichiometry of coupling is that for every two electrons which traverse the entire electron transport chain two molecules of ATP can be formed.

The mole for mole proportionality between ATP formation and the extra electron transport accompanying ATP formation results from measurements that can be made with precision and have been confirmed many times in the literature. Nevertheless, these data do not exclude the possibility that the phosphorylation process may alter the basal rate in such a fashion as to maintain the mole for mole proportionality just discussed. Portis and McCarty (1976) reported data which suggest that this is the case and that phosphorylating and non-phosphorylating electron flow are actually competing processes. Portis and McCarty concluded that the rate of proton leakage and hence the rate of nonphosphorylating electron transport shows a first order dependence on the concentration of protons in the inner aqueous chloroplast space. That is to say they considered basal electron flow to be a direct consequence of passive efflux of H^+ from the thylakoids. Therefore, when phosphorylation diminishes the internal H^+ concentration (if indeed it does), the rate of basal nonphosphorylating electron flow accompanying ATP formation should be less. By estimating the rate of basal electron transport from measurements of the internal proton concentration during phosphorylation, Portis and McCarty arrived at a corrected stoichiometry for the ATP formation process of 1.33. Thus the experimentally obtained values of 1.3 which are not infrequently observed would represent near perfect coupling and, by inference, virtually no remaining basal electron transport.

Referring to the schematic in Fig. 2, Izawa and Good have offered the interpretation that the electron transport driven " H^+ pump" can satu-

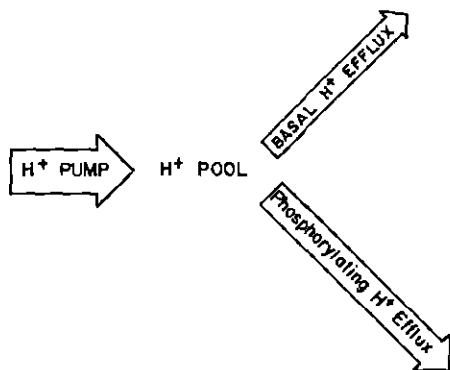

FIG. 2. Alternative proton efflux pathways.

rate the combined basal and phosphorylating H^+ efflux. That is, the size of the H^+ pool is the same whether basal H^+ efflux alone or in combination with phosphorylating efflux is occurring. It is known, for instance, that certain concentrations of amine uncouplers adequate to enhance basal electron transfer very significantly (and presumably non-phosphorylating proton efflux) do not decrease the rate of phosphorylation at all (Good *et al.*, 1966). Of course when electron transport is limited by light intensity, by the concentration or activity of the electron acceptor, or by an inhibitor such as DCMU, proton pumping would then be inadequate to saturate both efflux pathways and competition should and does occur. On the other hand, Portis and McCarty's data indicate that the combined efflux pathways do exceed the capacity of the electron transport driven proton uptake. In other words, the advent of the phosphorylating H^+ efflux pathway reduces the size of the H^+ pool and consequently reduces basal H^+ efflux. There are numerous demonstrations that phosphorylation can diminish the internal proton concentration but these are relevant here only if electron transport is not limited in the ways discussed earlier. In experiments by Telfer and Evans (1972), electron flux was intentionally limited by the concentration of electron acceptor. The activity of the electron acceptor in Gould and Izawa's (1974) study limited proton pumping. Examination of Schwartz's data (1968) indicates that in his experiments electron transport is limited by incident light intensity. Electron transport is also limited by light intensity in Portis and McCarty's (1974) report of a reduced ΔpH by phosphorylation. There is insufficient information in the publication of Pick *et al.* (1973) to judge whether electron transport was limited by anything other than the phosphorylating reactions. The strongest indication that phosphorylation does diminish the internal concentration of protons,

under conditions where (1) electron transport is not limited and (2) where there exists a mole for mole portionality between ATP formation and extra electron transport, are the experiments of Portis and McCarty (1976). In these experiments a reduction in phosphorylation by the energy transfer inhibitor deoxyphlorizin resulted in a proportionally constant decrease in electron flow with an accompanying increase in the ΔpH . In view of these divergent observations and arguments, we must conclude that the true $ATP/2e^-$ ratio for phosphorylation by chloroplast coupling factor remains uncertain.

2. H^+/e^-

We have discussed briefly in this chapter, and others have discussed in more detail in separate chapters of this volume, that a proposed alternating arrangement of the electron and hydrogen carriers in the thylakoid membrane can account for the formation of a transmembrane hydrogen ion activity difference. A great deal of evidence reviewed elsewhere (e.g., Jagendorf, 1975) supports the notion that reactions occurring near the inner surface of the lamellar membrane, specifically the oxidation of water by PSII reactions and the oxidation of plastoquinone directly or indirectly by Cyt *f*, are the reaction couples involved. Thus, the model predicts an H^+/e^- ratio of 2 in the transport of electrons from water to hydrophilic acceptors such as ferricyanide and ferrioxin, and there is general experimental support for this value.

Flash excitation of chloroplasts and rapid spectroscopic measurements of optical indicators of pH and electron transfer have been very useful in determining the H^+/e^- ratio in chloroplasts. These experiments are not devoid of problems such as possible flash-induced absorption changes of the pH indicator not associated with a pH change, the large number of repeated events sometimes needed to improve the data by signal averaging, and so on. Junge and Ausländer (1973) have dealt with these and other difficulties to conclude from their experiments that the release of one proton inside the lamella is associated with the turnover of each photosystem (i.e., the H^+/e^- ratio for the entire chain equals 2.0).

The alternative to "flash experiments" in which the number of protons taken up and the number of electrons transferred in response to a pulse of light are measured, is a comparison of proton flux rates with electron transport rates. Measurements of rates of proton flux, either influx or efflux, are most often made with a glass electrode. The experimental predicaments that have been encountered in these measurements are bountiful and have been discussed by Dilley and Giaquinta (1975). It appears that the most reliable data are obtained when difficul-

ties arising from the normally slow response of a glass electrode are avoided. Schwartz (1968) employed a rapidly responding glass electrode to measure initial rates of H^+ efflux immediately after the light was turned off. When this rate was compared with the electron transport rate measured just prior to when the light was extinguished, a value of 2.0 ± 0.3 was obtained for the H^+/e^- ratio. Izawa and Hind (1967) employed an ingenious system in which chloroplasts flowed at constant rate through an illuminated chamber and then passed a glass electrode. In these experiments values for the H^+/e^- of 2.2–2.6 were computed. Using a related technique, where the kinetics of the initial proton uptake were graphically reconstructed from a series of illumination periods several seconds in duration, Gould and Izawa (1974) reported a ratio of 1.7 for electrons originating from water and moving all the way through PSI. When electrons were transported through PSII alone and intercepted by DBMIB at or before plastoquinone a ratio of only 0.5 was observed, a result that may have arisen from protonation of approximately one half the DBMIB within the chloroplast, artificially reducing the value from 1.0. Using the identical technique Izawa *et al.* (1975) found the H^+/e^- for PSI electron flux was in the range of 0.9–1.1. Only one report opposes the notion that there are two sites of internal proton release for each electron that is transported through the entire chain. Employing a rapid glass electrode to measure flash-induced proton release, Fowler and Kok (1976) report that four protons were released internally when methylviologen was the added oxidant and three when ferricyanide replaced methylviologen. Subsequent experiments by Saphon and Crofts (1977) indicate that Fowler and Kok failed to take into account an increase in buffering capacity due to the addition of methylamine made for determination of electron transfer (electron transfer was measured from numbers of protons released from water oxidation). The electron transfer was therefore underestimated. When Saphon and Crofts corrected for this slight additional buffering H^+/e^- values near 2 were observed.

An electrogenic proton transfer occurring between the photosystems has been proposed in the green alga *Chlorella* (Bouges-Bocquet, 1977) and spinach chloroplasts (Velthuys, 1978), based on the discovery of a slow component of the electric field indicating 515 nm absorption change. This exciting new result is covered in detail by Cramer and Crofts in Chapter 9 of this volume and the reader is referred there for details. Under the conditions in which the electrogenic proton movement is believed to be operative, it may be that the H^+/e^- is elevated to a value of 3.0. We wonder if higher $ATP/2e^-$ values reported by Reeves

and Hall (1973) might be accountable by the operation of this "electrogenic proton pump" in their chloroplast preparations.

3. H^+/ATP

Determination of the stoichiometry for the coupling reaction of H^+ efflux to ATP formation is frustrated by the same uncertainties regarding the degree of coupling as is the computation of the $ATP/2e^-$ ratio. Accepting an H^+/e^- ratio of 2, the stoichiometry of proton efflux to ATP formation can be readily calculated employing the corrected values of the $ATP/2e^-$ discussed in Section IV, A, 1. Portis and McCarty's (1976) value for the $ATP/2e^-$ of 1.33 yields a value for the H^+/ATP ratio of 3. An $ATP/2e^-$ ratio equals 2.0, suggested by Izawa and Good (1968), results in a value of 2 for the H^+/ATP ratio.

Experimental determinations of this ratio have been made from the hydrolysis of ATP as well as from the synthesis reaction. It is generally held that hydrolysis of ATP by activated chloroplast coupling factor represents a reversal of the synthesis reaction. Measurements by Carmeli *et al.* (1975) of proton uptake induced by ATP hydrolysis in the dark, after light activation of the ATPase, yielded H^+/ATP ratios ranging from about 1.4 to 2.0 at pH 8.0. An apparent increase in the ratio was observed when the external pH was lowered. Gaennslen and McCarty (1971) measured the uptake of ethylamine by chloroplasts where the neutral amine moves in response to proton uptake associated with ATP hydrolysis. They report that approximately 1.7 amine Eq were taken up for each molecule of ATP hydrolyzed. Further support for an H^+/ATP ratio of 2 comes from determinations on the synthesis reaction. Izawa (1970) determined that between 2.2 and 2.7 protons were coupled to the postillumination synthesis of 1 molecule of ATP. In these experiments the degree of coupling of H^+ efflux to ATP synthesis was estimated from the rate of decay of the capacity to make ATP. Izawa's analysis assumes concurrent ATP synthesis does not alter the proportion of H^+ effluxing via a nonproductive pathway and does not take into account any minimum energetic threshold which must exist. Schwartz (1968) reported a ratio of close to 2 calculated from measurements of steady state rates of ATP formation and initial rates of H^+ efflux taken immediately after the light was extinguished.

H^+/ATP ratios of close to 3 have been reported by Schröder *et al.* (1972) in experiments similar to those of Schwartz (1968) but with the addition of valinomycin and K^+ to prevent the formation of an internally negative diffusion potential that would tend to slow proton efflux. A ratio of 3 was also reported by Witt (1971) but was subsequently raised

to 4 (Witt, 1975). The value now favored by Witt's group is about 2.5 protons per ATP (Gräber and Witt, 1976).

Portis and McCarty (1974) have studied the relationship of the rate of ATP formation to the ΔpH measured by hexylamine distribution. When electron transport rates were varied, for instance by light intensity, they report that semilogarithmic plots of phosphorylation rates against ΔpH produced a linear relationship with a slope ranging from about 3.0 to 3.5. They interpreted these plots to show a third order dependence of photophosphorylation on the internal H^+ concentration, which to them implied a H^+/ATP ratio of 3.

Experimental determinations of the H^+/ATP ratio for chloroplasts have not produced a consensus. Nevertheless, let us consider a value of 3.0, which some believe is a minimum number for energetic reasons since a lower proton requirement seems to imply an unacceptably large transmembrane pH difference. Recall the precise linear relationship between the increase in electron transport due to phosphorylation and the rate of phosphorylation. Over a very wide range of phosphorylation rates one extra electron is transported for each additional ATP produced. If each extra electron results in the internal release of 2H^+ but 3H^+ are needed for each additional ATP, the deficit must be filled by a redirection of the nonphosphorylating H^+ efflux pathway. In fact this redirection of H^+ efflux from a nonphosphorylating to phosphorylating pathway must be very exact so that for every 3H^+ used for phosphorylation, exactly one H^+ is redirected away from the basal pathway. If this were not the case the linear relationship between extra electrons transported and extra ATP molecules formed could not be maintained over a wide range of rates. This would seem to require a close mechanistic association between basal and phosphorylating electron flow, a concept which is not consistent with the notion that "basal" electron transport is due to a nonspecific proton leak. Generally, chemiosmotic systems are pictured as more loosely regulated than this. Such an association might account for the observation that the dependence of phosphorylating electron transport and basal electron transport on pH are virtually identical (Good *et al.*, 1966), and indicates that the pathway of basal H^+ efflux may be predominately through the coupling factor complex.

B. Bacterial Stoichiometries

1. H^+/e^-

In 1954 Frenkel reported that illuminated cell-free extracts from *Rs. rubrum* are able to form a significant amount of ATP. Unlike the chlo-

roplast system, an exogenous oxidant was not found to be necessary to mediate photophosphorylation. It is now understood that photosynthetic electron transport is predominantly cyclic in these bacterial membrane preparations. Consequently, determination of the quantitative relationship between electron flux and proton transfer is more difficult in bacterial preparations than in chloroplasts. These experimental difficulties have been obviated largely through the use of brief actinic flashes. When the flashes are short enough, the photochemical reactions are turned over only a single time and the number of electrons moved can be determined from the amount of a newly oxidized or reduced redox component. The number of protons moved in association with the pulse of light can be measured by an optical absorbance or fluorescent change of a pH-indicating dye.

There are two kinetic components to flash-induced binding of protons to bacterial chromatophores. Microsecond H^+ binding accompanying electron transport in photosynthetic bacteria was first observed by Chance *et al.* (1970). Using chromatophores from *Rp. sphaeroides*, Petty and Dutton (1976) further characterized this flash-induced antimycin-insensitive proton binding. At pH 7.0 they found that 1.0 ± 0.1 proton is bound per electron transferred from the reaction center to the quinone pool near the outer side of the chromatophore membrane. The half-time for antimycin-insensitive proton binding at pH 7.0 is about 120 μ sec. A second, slower antimycin-sensitive component of proton binding was observed by Cogdell *et al.* (1972). The antimycin-sensitive component of the time-resolved binding is thought to be associated with electron transfer through the UQ-Cyt *b/c*₂ oxidoreductase. The exact nature of the electron and proton transfer reactions is reviewed in detail by Cramer and Crofts in Chapter 9 of this volume. Petty *et al.* (1977) studied the stoichiometry of proton binding to electron transfer through the UQ-Cyt *b/c*₂ oxidoreductase of *Rp. sphaeroides*. Experiments at pH 6.0 showed between 0.5 and 0.9 antimycin-sensitive protons bound per electron. The exact kinetics of H^+ binding associated with UQ-Cyt 1 *b/c*₂ oxidoreductase activity depend upon the reduction state of Q_z and Cyt *c*₂ prior to the flash (see Cramer and Crofts, Chapter 9, this volume). Thus, it is clear that experimental conditions can be found where the combined proton binding of the reaction center and the UQ-Cyt *b/c*₂ oxidoreductase can account for nearly two protons for every electron transferred through the cyclic system.

2. H^+ /ATP AND H^+ /PP₁

The H^+ /ATP ratio for chromatophores has been reported from kinetic measurements of proton movements and from thermodynamic

comparison of Δp and ΔG_{ATP} (Section I,A). These two methods for the determination of the H^+/ATP ratio are not in agreement at low values of Δp (i.e., below ~ 250 mV). Jackson and colleagues (Jackson *et al.*, 1975; Petty *et al.*, 1977) have estimated the number of protons translocated during ATP synthesis from the effect of phosphorylation on the red shift of the carotenoid absorption spectrum. A small portion of the decay of the flash-induced carotenoid shift is accelerated by phosphorylating conditions (Jackson *et al.*, 1975; Saphon *et al.*, 1975b). Typically, in chromatophores, 5–30% of the absorption change is accelerated by concurrent ATP synthesis (Petty and Jackson, 1979a). The quantity of ATP formed was determined under nearly identical conditions by assay with luciferin/luciferase. Petty and Jackson reported H^+/ATP values for three strains of *Rp. capsulata* as well as *Rp. sphaeroides* Ga. The mean value they obtained was 2.25 ± 0.16 from 10 independent determinations. Using the acceleration of carotenoid absorbance band shift to monitor H^+ translocation associated with phosphorylation merits comment since the phenomenon cannot be said to be well understood. Anomalous behavior is observed with ATP since ATP stimulates the carotenoid shift decay in the same way as phosphorylation (Saphon *et al.*, 1975b). Petty and Jackson (1979a) report that ATP stimulation requires concomitant presence of P_i , and believe the effect to be dependent upon generation of ADP by ATP hydrolysis. More serious difficulties are pointed out by the studies of Girault and Galmiche (1976) with chloroplasts. $1, \text{N}^6$ -etheno-ADP is efficiently phosphorylated by chloroplasts but does not result in an acceleration of the decay of the carotenoid band shift. Girault and Galmiche conclude that the acceleration of the dark decay of the absorbance band shift is the result of the interaction of the newly synthesized ATP with the coupling factor complex, an interaction that newly synthesized $1, \text{N}^6$ -etheno-ATP cannot participate in. Petty and Jackson (1979a) confirmed these observations but point out that the conclusions of Girault and Galmiche do not take cognizance of the P_i requirement of the ATP-dependent stimulation. An alternate explanation is that $1, \text{N}^6$ -etheno-ADP is not efficiently phosphorylated under flash excitation thus no acceleration would be expected (Petty and Jackson, 1979a). These are clearly important matters to be resolved.

The free energy stored in ATP at "static head" conditions for photophosphorylation is related to the magnitude of the Δp . In Section I,B we discussed equilibrium in terms of the following relationship:

$$\Delta G_{\text{ATP}} = Z_{\text{HP}} F \Delta p$$

In this context Z_{HP} is equivalent to the number of protons translocated through the ATPase complex for each molecule of ATP synthesized

(i.e., $Z_{HP} = H^+/ATP$), provided that the degree of coupling of the ATPase is close to 1. Thus if the value of Z_{HP} is fixed by the molecular mechanism of the ATPase, there should be a constant relationship between ΔG_{ATP} and Δp . Baccarini-Melandri *et al.* (1977) measured the magnitude of Δp in *Rp. capsulata* chromatophores employing 9-aminoacridine fluorescence quenching (ΔpH) and the red shift of the carotenoid absorption band ($\Delta\psi$). They found a constant relationship between ΔG_{ATP} and Δp in well-coupled chromatophore membranes. A value of $Z = 2$, that is $2H^+/ATP$, was adequate to account for the equilibrium forces measured experimentally. However, as chromatophores were progressively uncoupled by addition of any one of a variety of agents, a minimal stoichiometry of $2H^+/ATP$ became inadequate below a Δp of about 250 mV. Related observations have been reported by Kell *et al.* (1978). The exact value of the Δp in chromatophores is controversial because values very different from those measured spectrophotometrically were reported when ion distribution techniques were utilized (see Section III,A and also Junge and Jackson, Chapter 13, this volume).

Chromatophore membranes of at least some photosynthetic bacteria contain an oligomycin-insensitive reversible pyrophosphatase that is a separate energy transduction pathway from the oligomycin-sensitive ATPase (Baltscheffsky and von Stedingk, 1966; Keister and Yike, 1967; Keister and Minton, 1971). Moyle *et al.* (1972) demonstrated that hydrolysis of inorganic pyrophosphate by the pyrophosphatase system of *Rs. rubrum* is accompanied by the translocation of protons. The stoichiometry of protons translocated to pyrophosphate molecules hydrolyzed was measured and the ratio found to be about 0.5. Moyle *et al.* felt that pyrophosphate hydrolysis was not well coupled to measurable proton movements due to some misoriented chromatophores and perhaps also to a different enzymatic pyrophosphatase activity not resulting in transmembrane proton movement.

3. $ATP/2e^-$

Measurement of the $ATP/2e^-$ ratio during continuous illumination is routine in chloroplasts but entirely impossible in chromatophores owing to the cyclic nature of the electron transport. Consequently the few experimental determinations of the $ATP/2e^-$ ratio that have been made for chromatophores exploited the same sort of flashing light techniques as were needed for H^+/e^- determinations.

In the experiments of Petty and Jackson (1979b) discussed in Section IV,B,2, $ATP/2e^-$ values can be calculated from their measurements of flash-induced phosphorylation of ADP and generation of oxidized reac-

tion center bacteriochlorophyll. In ten determinations the $\text{ATP}/2e^-$ ratio ranged from 0.05 to 0.24 with a mean of 0.14. In these experiments the chromatophores were excited with single turnover flashes spaced 50 sec apart. An explanation for these very low efficiencies is found in the experiments of Melandri *et al.* (1980). The yield of ATP is a function of flash number. The ATP yield from the initial four flashes, after an extended dark period, is controlled by the phosphate potential. No ATP is formed in the initial three turnovers at a phosphate potential of 11.5 kcal/mol, whereas at 8.2 kcal/mol only the ATP yield of the first flash is low (about one-half that of subsequent flashes). These data demonstrate that the $\text{ATP}/2e^-$ ratio obtained will depend on flash number as well as phosphate potential. Moreover ATP yields vary according to the dark time between flashes, reaching a maximum when flashes are separated by 160–320 msec. Thus in the studies of Petty and Jackson (1979b) in which 50-sec separated flashes each would be equivalent to the first flash after a dark period and low yields would be expected. A true $\text{ATP}/2e^-$ ratio, comparable to that measured in continuous light in a linear system, can therefore be measured only when a sufficiently high Δp has been formed (i.e., after at least 4–6 flashes), and a pseudosteady state has been achieved. In experiments of this kind Jackson *et al.* (1980) could measure an optimal $\text{ATP}/2e^-$ ratio of 1.1 from trains of flashes spaced 160–320 msec apart. Much earlier Nishimura and Chance (1963) had suggested from their data obtained with multiple turnover flashes that the $\text{ATP}/2e^-$ ratio was 2.

The question of the degree of coupling is as significant in bacterial chromatophores as it is in chloroplasts. If the transport of each electron results in the transfer of two protons and a molecule of ATP can be formed for each pair of protons passing through the coupling factor, the true stoichiometry of the coupling process would be $\text{ATP}/2e^- = 2$. The experiments of Petty and Jackson (1979b) suggest that the rate constant for proton efflux coupled to ATP formation is significantly greater than the rate constant for the noncoupled efflux. The minimal consequence of this interpretation would be that the coupling factor complex senses the Δp and conducts protons more rapidly when ΔG_{ATP} is less than Δp . An exact evaluation of the degree of coupling of ATP synthesis to electron flow in chromatophores is practically impossible. In experiments with trains of single turnover flashes a degree of coupling around 0.85 was estimated (Jackson *et al.*, 1980).

In this chapter, we have tried to provide an overview on the mechanism of photophosphorylation (ATP synthesis) in plants and photosynthetic bacteria. A detailed discussion on the membrane potential ($\Delta\psi$) component of the Δp is presented by Junge and Jackson in the following

chapter. McCarty and Carmeli (Chapter 14) discuss the structure and the function of the enzyme ATPase. The reader is encouraged to consult these chapters as well as Chapter 9 by Cramer and Crofts that deals with the electron and proton transport that precede phosphorylation.

REFERENCES

- Armstrong, G. (1975). *Biophys. J.* **15**, 932–933.
- Arnon, D., Allen, M., and Whately, F. (1954). *Nature (London)* **174**, 394–396.
- Arntzen, C., Dilley, R., and Crane, F. (1969). *J. Cell Biol.* **43**, 16–31.
- Avron, M. (1972). *Proc. Int. Congr. Photosynth., 2nd, 1971* pp. 861–871.
- Avron, M., and Chance, B. (1967). *Brookhaven Symp. Biol.* **19**, 149–160.
- Baccarini-Melandri, A., and Melandri, B. (1971). In "Methods in Enzymology" (A. San Pietro, ed.), Vol. 23, pp. 556–561. Academic Press, New York.
- Baccarini-Melandri, A., and Melandri, B. (1978). In "The Photosynthetic Bacteria" (R. Clayton and W. Sistrom, eds.), pp. 615–628. Plenum, New York.
- Baccarini-Melandri, A., Fabbri, E., and Melandri, B. (1975). *Biochim. Biophys. Acta* **376**, 82–88.
- Baccarini-Melandri, A., Casadio, R., and Melandri, B. (1977). *Eur. J. Biochem.* **78**, 389–402.
- Balscheffsky, H., and von Stedingk, L. (1966). *Biochem. Biophys. Res. Commun.* **22**, 722–728.
- Boeck, M., and Witt, H. (1972). *Proc. Int. Congr. Photosynth., 2nd, 1971* pp. 903–911.
- Böger, P., and San Pietro, A. (1967). *Z. Pflanzenphysiol.* **58**, 70–75.
- Boguslavsky, L., Kondrashin, A., Kozlov, I., Metelsky, S., Skulachev, V., and Volkov, A. (1975). *FEBS Lett.* **50**, 223–226.
- Bouges-Bocquet, B. (1977). *Biochim. Biophys. Acta* **462**, 371–379.
- Boyer, P., Chance, B., Ernster, L., Mitchell, P., Racker, E., and Slater, E. (1977). *Annu. Rev. Biochem.* **46**, 955–1026.
- Caplan, S. (1971). *Curr. Top. Bioenerg.* **4**, 1–65.
- Caplan, S., and Essig, A. (1969). *Proc. Natl. Acad. Sci. U.S.A.* **64**, 211–218.
- Carmeli, C., Lifshitz, Y., and Gepshtein, A. (1975). *Biochim. Biophys. Acta* **376**, 249–258.
- Casadio, R., Baccarini-Melandri, A., and Melandri, B. (1974a). *Eur. J. Biochem.* **47**, 121–128.
- Casadio, R., Baccarini-Melandri, A., Zannoni, D., and Melandri, B. (1974b). *FEBS Lett.* **49**, 203–207.
- Casadio, R., Baccarini-Melandri, A., and Melandri, B. (1978). *FEBS Lett.* **87**, 323–328.
- Chance, B., Crofts, A., Nishimura, M., and Price, B. (1970). *Eur. J. Biochem.* **13**, 364–374.
- Cogdell, R., Jackson, J., and Crofts, A. (1972). *Bioenergetics* **4**, 413–429.
- Crofts, A. (1968). In "Regulatory Functions of Biological Membranes" (J. Jarnefelt, ed.), pp. 247–263. Elsevier, Amsterdam.
- Crofts, A., and Wood, P. (1978). *Curr. Top. Bioenerg.* **7**, 175–244.
- Crofts, A., Wraight, C., and Fleischmann, D. (1971). *FEBS Lett.* **15**, 89–100.
- Crofts, A., Crowther, D., and Tierney, G. (1975). In "Electron Transport and Oxidative Phosphorylation" (E. Quagliariello, S. Papa, F. Palmieri, E. Slater, and N. Siliprandi, eds.), pp. 233–241. North-Holland Publ., Amsterdam.
- Davenport, J., and McCarty, R. (1980). *Biochim. Biophys. Acta* **589**, 353–357.
- Deamer, D., and Packer, L. (1969). *Biochim. Biophys. Acta* **172**, 539–545.

- Del Valle-Tascon, S., van Grondelle, R., and Duysens, L. (1978). *Biochim. Biophys. Acta* **504**, 26-39.
- Dilley, R., and Giaquinta, R. (1975). *Curr. Top. Membr. Transp.* **7**, 49-107.
- Dilley, R., and Vernon, L. (1965). *Arch. Biochem. Biophys.* **111**, 365-375.
- Feher, G., and Okamura, M. (1977). *Brookhaven Symp. Biol.* **28**, 183-194.
- Ferguson, S., Jones, O., Kell, D., and Sorgato, M. (1979). *Biochem. J.* **180**, 75-85.
- Fowler, C., and Kok, B. (1974). *Biochim. Biophys. Acta* **357**, 308-318.
- Fowler, C., and Kok, B. (1976). *Biochim. Biophys. Acta* **423**, 510-523.
- Frenkel, A. (1954). *J. Am. Chem. Soc.* **76**, 5568-5569.
- Gaensslen, R., and McCarty, R. (1971). *Arch. Biochem. Biophys.* **147**, 55-65.
- Gepshtein, A., and Carmeli, C. (1974). *Eur. J. Biochem.* **44**, 593-602.
- Girault, G., and Galmiche, J. (1976). *Biochem. Biophys. Res. Commun.* **68**, 724-729.
- Good, N., and Bell, D. (1980). In "Photosynthesis, Plant Production and Crop Yield" (P. S. Carlson, ed.), pp. 3-51. Academic Press, New York.
- Good, N., Izawa, S., and Hind, G. (1966). *Curr. Top. Bioenerg.* **1**, 75-112.
- Gould, J., and Izawa, S. (1974). *Biochim. Biophys. Acta* **333**, 509-524.
- Graan, T., and Ort, D. (1981). *Proc. Int. Congr. Photosynth., 5th, 1980* 935-944.
- Gräber, P., and Witt, H. (1974). *Biochim. Biophys. Acta* **333**, 389-392.
- Gräber, P., and Witt, H. (1976). *Biochim. Biophys. Acta* **423**, 141-163.
- Gräber, P., Schlodder, E., and Witt, H. (1977). *Biochim. Biophys. Acta* **461**, 426-440.
- Gromet-Elhanan, Z., and Leiser, M. (1975). *J. Biol. Chem.* **250**, 90-93.
- Harris, D., and Crofts, A. (1978). *Biochim. Biophys. Acta* **502**, 87-102.
- Hauska, G., and Sane, P. (1972). *Z. Naturforsch., B: Anorg. Chem., Org. Chem., Biochem., Biophys., Biol.* **27B**, 938-942.
- Hauska, G., and Trebst, A. (1977). *Curr. Top. Bioenerg.* **6**, 151-220.
- Hind, G., Nakatani, H., and Izawa, S. (1974). *Proc. Natl. Acad. Sci. U.S.A.* **71**, 1484-1488.
- Hope, A., and Moreland, A. (1979). *Aust. J. Plant Physiol.* **6**, 289-304.
- Izawa, S. (1970). *Biochim. Biophys. Acta* **223**, 165-173.
- Izawa, S., and Good, N. (1968). *Biochim. Biophys. Acta* **162**, 380-391.
- Izawa, S., and Hind, G. (1967). *Biochim. Biophys. Acta* **143**, 377-390.
- Izawa, S., and Ort, D. (1974). *Biochim. Biophys. Acta* **357**, 127-143.
- Izawa, S., and Pan, R. (1978). *Biochem. Biophys. Res. Commun.* **83**, 1171-1177.
- Izawa, S., Gould, J., Ort, D., Felker, P., and Good, N. (1973). *Biochim. Biophys. Acta* **305**, 119-128.
- Izawa, S., Ort, D., Gould, J., and Good, N. (1975). *Proc. Int. Congr. Photosynth., 3rd, 1974* pp. 449-461.
- Jackson, J. (1975). *Proc. Int. Congr. Photosynth., 3rd, 1974* pp. 757-767.
- Jackson, J., and Crofts, A. (1971). *Eur. J. Biochem.* **18**, 120-130.
- Jackson, J., and Dutton, P. (1973). *Biochim. Biophys. Acta* **325**, 102-113.
- Jackson, J., Crofts, A., and von Stedingk, L. (1968). *Eur. J. Biochem.* **6**, 41-54.
- Jackson, J., Saphon, S., and Witt, H. (1975). *Biochim. Biophys. Acta* **408**, 83-92.
- Jackson, J., Baccarini-Melandri, A., Venturoli, G., and Melandri, B. (1981). *Biochim. Biophys. Acta* **636**, 1-8.
- Jagendorf, A. (1975). In "Bioenergetics of Photosynthesis" (Govendjee, ed.), pp. 413-492. Academic Press, New York.
- Jagendorf, A., and Uribe, E. (1966). *Proc. Natl. Acad. Sci. U.S.A.* **55**, 170-177.
- Jain, M. (1972). "The Bimolecular Lipid Membrane." p. 91. Van Nostrand-Reinhold, Princeton, New Jersey.
- Junge, W. (1970). *Eur. J. Biochem.* **14**, 582-592.
- Junge, W. (1975). *Proc. Int. Congr. Photosynth., 3rd, 1974* pp. 273-286.

- Junge, W. (1977). *Encycl. Plant Physiol., New Ser.* 5, 59–93.
- Junge, W., and Ausländer, W. (1973). *Biochim. Biophys. Acta* 333, 59–70.
- Junge, W., and Witt, H. (1968). *Z. Naturforsch. B: Anorg. Chem., Org. Chem., Biochem., Biophys., Biol.* 23B, 244–254.
- Junge, W., Rumberg, B., and Schröder, H. (1970). *Eur. J. Biochem.* 14, 575–581.
- Junge, W., McGeer, A., Ausländer, W., and Kollia, J. (1978). In "Energy Conservation in Biological Membranes" (G. Schafer and M. Klingenberg, eds.), pp. 113–127. Springer-Verlag, Berlin and New York.
- Junge, W., Ausländer, W., McGeer, A., and Runge, T. (1979). *Biochim. Biophys. Acta* 546, 121–141.
- Katchalsky, A., and Curran, F. (1965). "Non-Equilibrium Thermodynamics in Biophysics." Harvard Univ. Press, Cambridge, Massachusetts.
- Katoh, S., Suga, I., Shiratori, I., and Takamiya, A. (1961). *Arch. Biochem. Biophys.* 94, 136–141.
- Keister, D., and Minton, N. (1969). *Proc. Natl. Acad. Sci. U.S.A.* 63, 489–495.
- Keister, D., and Minton, N. (1971). *Arch. Biochem. Biophys.* 147, 330–338.
- Keister, D., and Yike, N. (1967). *Arch. Biochem. Biophys.* 121, 415–422.
- Kell, D. (1979). *Biochim. Biophys. Acta* 549, 55–99.
- Kell, D., Ferguson, S., and John, P. (1978). *Biochim. Biophys. Acta* 502, 111–126.
- Kraayenhof, R. (1969). *Biochim. Biophys. Acta* 180, 213–215.
- Läuger, P. (1972). *Science* 178, 24–30.
- Leiser, M., and Gromet-Elhanan, Z. (1975). *J. Biol. Chem.* 250, 84–89.
- Leiser, M., and Gromet-Elhanan, Z. (1977). *Arch. Biochem. Biophys.* 178, 79–88.
- Lundin, A., Thore, A., and Baltscheffsky, M. (1977). *FEBS Lett.* 79, 73–76.
- McCarty, R. (1978). *Curr. Top. Bioenerg.* 7, 245–278.
- McCarty, R. (1980). In "Methods in Enzymology" (A. San Pietro, ed.), Vol. 69, pp. 719–728. Academic Press, New York.
- McCarty, R., and Racker, E. (1967). *Brookhaven Symp. Biol.* 19, 202–214.
- Malkin, R., and Aparicio, P. (1975). *Biochem. Biophys. Res. Commun.* 63, 1157–1160.
- Matsuura, K., Masamoto, K., Itoh, S., and Nishimura, M. (1979). *Biochim. Biophys. Acta* 547, 91–102.
- Melandri, B. (1977). *Encycl. Plant Physiol., New Ser.* 5, 358–368.
- Melandri, B., Baccarini-Melandri, A., San Pietro, A., and Gest, H. (1970). *Proc. Natl. Acad. Sci. U.S.A.* 67, 477–482.
- Melandri, B., Casadio, R., and Baccarini-Melandri, A. (1978a). *Proc. Int. Congr. Photosynth., 4th, 1977* pp. 601–609.
- Melandri, B., DeSantis, A., Venturoli, G., and Baccarini-Melandri, A. (1978b). *FEBS Lett.* 95, 130–134.
- Melandri, B., Venturoli, G., DeSantis, A., and Baccarini-Melandri, A. (1980). *Biochim. Biophys. Acta* 592, 38–52.
- Michels, P., and Konigs, W. (1978). *Eur. J. Biochem.* 85, 147–155.
- Miller, K., and Staehelin, L. (1976). *J. Cell Biol.* 68, 30–47.
- Mitchell, P. (1968). "Chemiosmotic Coupling and Energy Transduction." Glynn Res., Bodmin, Cornwall, England.
- Mitchell, P. (1976). *J. Theor. Biol.* 62, 327–367.
- Mitchell, P. (1977). *FEBS Lett.* 78, 1–20.
- Moyle, J., Mitchell, R., and Mitchell, P. (1972). *FEBS Lett.* 23, 233–236.
- Nakatani, H., Barber, J., and Forrester, J. (1978). *Biochim. Biophys. Acta* 504, 215–225.
- Nelson, N., Nelson, H., Naim, Y., and Neumann, J. (1971). *Arch. Biochem. Biophys.* 145, 263–267.

- Nelson, N., Eytan, E., Notsani, B.-E., Sigrist, H., Sigrist-Nelson, K., and Gitler, C. (1977). *Proc. Natl. Acad. Sci. U.S.A.* **74**, 2375-2378.
- Nishimura, M., and Chance, B. (1963). In "Studies on Microalgae and Photosynthetic Bacteria" (J. Ashida, ed.), p. 239. Univ. of Tokyo Press, Tokyo.
- Odum, H., and Pinkerton, R. (1955). *Am. Sci.* **43**, 331-343.
- Okamoto, H., Sone, N., Hirata, H., Yoshida, M., and Kagawa, Y. (1977). *J. Biol. Chem.* **252**, 6125-6131.
- O'Keefe, D., and Dilley, R. (1977). *Biochim. Biophys. Acta* **461**, 48-60.
- Ort, D. (1978). *Eur. J. Biochem.* **85**, 479-485.
- Ort, D., and Dilley, R. (1976). *Biochim. Biophys. Acta* **449**, 95-107.
- Ort, D., and Izawa, S. (1978). *Plant Physiol.* **52**, 595-600.
- Ort, D., Dilley, R., and Good, N. (1976). *Biochim. Biophys. Acta* **449**, 108-124.
- Ort, D., Dilley, R., and Good, N. (1978). *Proc. Int. Congr. Photosynth., 4th, 1977* pp. 581-590.
- Packham, N., Berriman, J., and Jackson, J. (1978). *FEBS Lett.* **89**, 205-210.
- Papa, S. (1976). *Biochim. Biophys. Acta* **456**, 39-84.
- Park, R., and Sane, P. (1971). *Annu. Rev. Plant Physiol.* **22**, 395-430.
- Petty, K., and Dutton, P. (1976). *Arch. Biochem. Biophys.* **172**, 335-345.
- Petty, K., and Jackson, J. (1979a). *Biochim. Biophys. Acta* **547**, 463-473.
- Petty, K., and Jackson, J. (1979b). *FEBS Lett.* **97**, 367-372.
- Petty, K., Jackson, J., and Dutton, P. (1977). *FEBS Lett.* **84**, 299-303.
- Pick, U., and Avron, M. (1976). *FEBS Lett.* **65**, 348-353.
- Pick, U., Rottenberg, H., and Avron, M. (1973). *FEBS Lett.* **32**, 91-94.
- Pick, U., Rottenberg, H., and Avron, M. (1974). *FEBS Lett.* **48**, 32-36.
- Pick, U., Rottenberg, J., and Avron, M. (1975). *Proc. Int. Congr. Photosynth., 3rd, 1974* pp. 967-974.
- Portis, A., and McCarty, R. (1974). *J. Biol. Chem.* **249**, 6250-6254.
- Portis, A., and McCarty, R. (1976). *J. Biol. Chem.* **251**, 1610-1617.
- Prince, R., Baccarini-Melandri, A., Hauska, G., Melandri, B., and Crofts, A. (1975). *Biochim. Biophys. Acta* **387**, 212-227.
- Prochaska, L., and Dilley, R. (1978a). *Arch. Biochem. Biophys.* **187**, 61-71.
- Prochaska, L., and Dilley, R. (1978b). *Biochem. Biophys. Res. Commun.* **83**, 664-672.
- Reeves, S., and Hall, D. (1973). *Biochim. Biophys. Acta* **314**, 66-78.
- Robinson, S., and Wiskich, J. (1976). *Biochim. Biophys. Acta* **440**, 131-146.
- Rosing, J., and Slater, E. (1972). *Biochim. Biophys. Acta* **267**, 275-290.
- Rottenberg, H. (1975). *J. Bioenerg.* **7**, 61-74.
- Rottenberg, H. (1977). *Encycl. Plant Physiol., New Ser.* **5**, 338-349.
- Rottenberg, H. (1978). *Prog. Surf. Membr. Sci.* **12**, 245-325.
- Rottenberg, H. (1979). *Biochim. Biophys. Acta* **549**, 225-253.
- Rottenberg, H., and Grunwald, T. (1972). *Eur. J. Biochem.* **25**, 71-74.
- Rottenberg, H., Grunwald, T., and Avron, M. (1972). *Eur. J. Biochem.* **25**, 54-63.
- Rumberg, B. (1977). *Encycl. Plant Physiol., New Ser.* **5**, 405-415.
- Rumberg, B., and Siggel, U. (1968). *Z. Naturforsch., B: Anorg. Chem., Org. Chem., Biochem., Biophys., Biol.* **23B**, 239-244.
- Rumberg, B., and Siggel, U. (1969). *Naturwissenschaften* **58**, 130-132.
- Saphon, S., and Crofts, A. (1977). *Z. Naturforsch., C: Biosci.* **32C**, 810-816.
- Saphon, S., Jackson, J., Lerbs, V., and Witt, H. (1975a). *Biochim. Biophys. Acta* **408**, 58-66.
- Saphon, S., Jackson, J., and Witt, H. (1975b). *Biochim. Biophys. Acta* **408**, 67-82.
- Schliephake, W., Junge, W., and Witt, H. (1968). *Z. Naturforsch., B: Anorg. Chem., Org. Chem., Biochem., Biophys., Biol.* **23B**, 1571-1578.

- Schmidt, R., and Junge, W. (1975). *Proc. Int. Congr. Photosynth.*, 3rd, 1974 pp. 821–830.
- Schröder, H., Muhle, R., and Rumberg, B. (1972). *Proc. Int. Congr. Photosynth.*, 2nd, 1971 pp. 919–930.
- Schuldiner, S., Rottenberg, H., and Avron, M. (1972a). *Eur. J. Biochem.* **25**, 64–70.
- Schuldiner, S., Rottenberg, H., and Avron, M. (1972b). *FEBS Lett.* **28**, 173–176.
- Schuldiner, S., Padan, E., Rottenberg, H., Gromet-Elhanan, Z., and Avron, M. (1974). *FEBS Lett.* **49**, 174–177.
- Schwartz, M. (1968). *Nature (London)* **219**, 915–919.
- Sebald, W., Hoppe, J., and Wachter, E. (1979). In "Function and Molecular Aspects of Biomembrane Transport" (E. Quagliariello, F. Palmieri, S. Papa, and M. Klingenberg, eds.), pp. 63–74. Elsevier/North-Holland, Amsterdam.
- Smith, D., Stokes, B., and Boyer, P. (1976). *J. Biol. Chem.* **251**, 4165–4171.
- Strotmann, H., Hesse, H., and Edelmann, K. (1973). *Biochim. Biophys. Acta* **314**, 202–210.
- Strotmann, H., Bickel, S., and Huchzermeyer, B. (1976). *FEBS Lett.* **61**, 194–198.
- Telfer, A., and Evans, M. (1972). *Biochim. Biophys. Acta* **256**, 625–637.
- Tiemann, R., Renge, G., Gräber, P., and Witt, H. (1979). *Biochim. Biophys. Acta* **546**, 498–519.
- Trebst, A. (1974). *Annu. Rev. Plant Physiol.* **25**, 423–458.
- Trebst, A., and Reimer, S. (1973). *Biochim. Biophys. Acta* **305**, 129–139.
- Uribe, E. (1972). *Biochemistry* **11**, 4228–4235.
- Velthuys, B. (1978). *Proc. Natl. Acad. Sci. U.S.A.* **75**, 6031–6034.
- Vinkler, C., Avron, M., and Boyer, P. (1978). *FEBS Lett.* **96**, 129–134.
- Vinkler, C., Avron, M., and Boyer, P. (1980). *J. Biol. Chem.* **255**, 2263–2266.
- Walz, D. (1979). *Biochim. Biophys. Acta* **505**, 279–353.
- Wax, E., and Lockau, W. (1980). *Z. Naturforsch., C: Biosci.* **35C**, 98–105.
- Webster, G., and Jackson, J. (1978). *Biochim. Biophys. Acta* **503**, 135–154.
- Whitmarsh, J., and Cramer, W. (1979a). *Proc. Natl. Acad. Sci. U.S.A.* **76**, 4417–4420.
- Whitmarsh, J., and Cramer, W. (1979b). *Biophys. J.* **26**, 223–234.
- Wikström, M. (1977). *Nature (London)* **266**, 271–273.
- Williams, R. (1961). *J. Theor. Biol.* **1**, 1–13.
- Williams, R. (1978a). *Biochim. Biophys. Acta* **505**, 1–44.
- Williams, R. (1978b). *FEBS Lett.* **85**, 9–19.
- Winget, G., Izawa, S., and Good, N. (1965). *Biochem. Biophys. Res. Commun.* **21**, 438–443.
- Winget, G., Izawa, S., and Good, N. (1969). *Biochemistry* **8**, 2067–2074.
- Witt, H., (1971). *Q. Rev. Biophys.* **4**, 365–477.
- Witt, H. (1975). In "Bioenergetics of Photosynthesis" (Govindjee, ed.), pp. 493–554. Academic Press, New York.
- Witt, H. (1979). *Biochim. Biophys. Acta* **505**, 355–427.
- Witt, H., and Zickler, A. (1973). *FEBS Lett.* **37**, 307–310.
- Witt, H., Schlodder, E., and Gräber, P. (1976). *FEBS Lett.* **69**, 272–276.
- Witt, H., Schlodder, E., and Gräber, P. (1977). In "Bioenergetics of Membranes" (L. Packer, C. C. Papageorgiou, and A. Trebst, eds.), pp. 447–457. Elsevier, Amsterdam.
- Wolff, C., Buchwald, H., Ruppel, H., Witt, K., and Witt, H. (1969). *Z. Naturforsch., B:* **24B**, 1038–1041.
- Zickler, A., Witt, H., and Boheim, G. (1976). *FEBS Lett.* **66**, 142–148.

The Development of Electrochemical Potential Gradients across Photosynthetic Membranes

WOLFGANG JUNGE
J. BAZ JACKSON

I. Introduction.....	590
II. The Membrane.....	594
A. Vesicle Size and Shape.....	594
B. Electrochemical Parameters.....	594
III. Measurement of Membrane Potential.....	598
A. Electrodes.....	598
B. Electrochromism in Thylakoids and Chromatophores.....	600
C. Extrinsic Voltage Probes.....	606
D. Ion Redistribution.....	607
E. Delayed Fluorescence.....	608
IV. Electrogenic Reactions in Thylakoids and Chromatophores.....	609
A. Electrogenic Reactions in Thylakoids.....	609
B. Electrogenic Reaction Steps in Chromatophores.....	617
C. Intrinsic and Artificially Induced Ionic Conductivity of Thylakoid and Chromatophore Membranes.....	623
D. Localized versus Delocalized Electric Fields.....	625
V. Protolytic Reactions in Thylakoids and in Chromatophores.....	626
A. pH-Indicating Dyes.....	626
B. Protolytic Reactions Involving Quinones.....	628
C. Proton Release inside Thylakoids during Water Oxidation.....	632
VI. Concluding Remarks and Working Hypotheses.....	634
A. Thylakoids.....	634
B. Chromatophores.....	637
C. Comparative Aspects.....	638
References.....	639

ABBREVIATIONS

BChl	Bacteriochlorophyll
Car	Carotenoid(s)
Chl	Chlorophyll
Chr.	<i>Chromatium</i>
Cyt.	Cytochrome
DBMIB	2,5-Dibromo-3-methyl-6-isopropyl- <i>p</i> -benzoquinone

ESR	Electron spin (paramagnetic) resonance
LH	Light harvesting
PS	Photosystem
PQ	Plastoquinone
RC	Reaction center
<i>Rp.</i>	<i>Rhodospseudomonas</i>
<i>Rs.</i>	<i>Rhodospirillum</i>
UQ	Ubiquinone

ABSTRACT

The electrochemical potential difference of the proton across the thylakoid membrane in green plant chloroplasts or across the cytoplasmic membrane of photosynthetic bacteria serves as intermediate during light-driven synthesis of ATP. The chemiosmotic concept views the membrane as a proton insulator that separates two aqueous phases. Electron transport, which is powered by photochemical reactions, drives proton translocation and special conduction pathways for protons through the membrane bound ATP-synthases make use of the electrochemical energy. In this chapter the electrochemical view of the membrane is examined. We begin the chapter by describing the measurements of the electrochemical parameters.

The two components of the electrochemical potential difference have been most conveniently measured by spectrophotometric techniques, the electrical potential difference via the electrochromic response of intrinsic pigments and the pH difference via extrinsic pH-indicating dyes. We describe how these techniques compare with others.

The very high sensitivity and the extreme rapidity of the respective dye responses has led to detailed information on how the electrochemical energy is generated, used, or dissipated. This chapter is focused on the generation. In both types of photosynthetic organisms one part of the electrical component is a direct consequence of the primary photochemical charge separation, while another part arises from subsequent electron transfer steps. The major portion of the pH difference is generated during redox reactions which involve quinones plus the oxidation of water in green plants. This is in line with the simple electron-hydrogen loop scheme of the early chemiosmotic hypothesis. However, there are several features which complicate this view. Their functional relevance is not well understood and they present a challenge to further research on the interplay of electrons and protons in photosynthesis.

I. Introduction

Biological membranes are invariably traversed by electric potentials ranging from a few millivolts up to several hundred millivolts. These potentials may arise from an unequal distribution of fixed charges or from active (energy-requiring) translocation of charges across the membrane. In the plasma membrane of photosynthetic bacteria and in the thylakoid membrane of green plants, light promotes active proton transport and charges the membrane both electrically and chemically. Proton pumping is caused by electron transport (mainly linear in green plants; only cyclic, in bacteria; see Fig. 1) which is the primary consequence of light absorption. The electrochemical potential difference of the proton

is used by a proton translocating ATP synthase for the production of ATP, the free energy carrier of the cell.

The causality chain—light absorption, electron transport, proton pumping, proton recycling, and ATP synthesis—was originally hypothesized by Mitchell (1961, 1966). Controversial for over a decade (for a review, see Boyer *et al.*, 1977), it is now experimentally established although detailed mechanistic features are still in contention.

The thylakoid membranes in green plant chloroplasts are highly specialized organelles (see Arntzen and Briantais, 1975; Kaplan & Arntzen, Chapter 3, this volume). Their function is to provide NADPH and ATP by light-driven electron transport from water, for the reduction of carbon dioxide to carbohydrate in the chloroplast stroma (see Govindjee, 1982). They form disk-shaped vesicles (diameter ~ 500 nm and thickness 5–20 nm) which are often arrayed in stacks (grana) with their internal phases largely interconnected. Substrate transport systems are unnecessary since NADPH and ATP are generated on the stroma side (outside) of the thylakoid.

On the other hand, the plasma membrane of photosynthetic bacteria has to serve a number of functions. Substrate transport systems are required, and in the Rhodospirillaceae (the family which includes most of the favorite species for bioenergetic studies), both photosynthetic and respiratory components abound. When grown under photoheterotrophic conditions on reduced organic acids, there is no major requirement for light-driven reduction of pyridine nucleotide and the photosynthetic electron transport pathway is predominantly cyclic. In some situations reduction of NAD by weakly reducing substrates may be driven by H^+ translocated during cyclic electron flow (Fig. 1). The plasma membrane

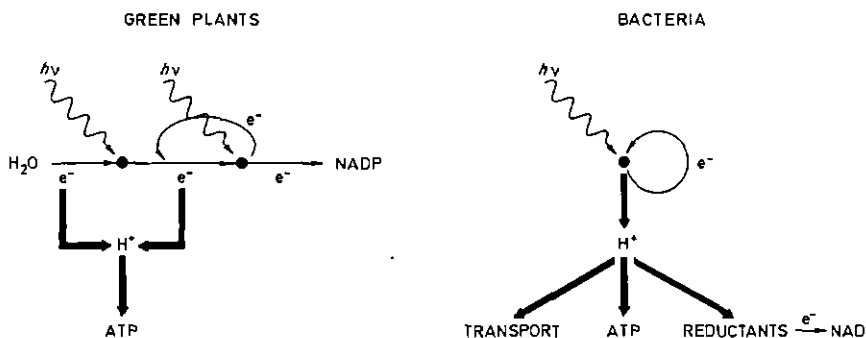

FIG. 1. Schematic representation of the causality sequence: light ($h\nu$) absorption—electron transport (thin lines)—proton (H^+) pumping (thick lines)—and usage of protons (thick lines) to do biological work. Left: in green plants, Right: in photosynthetic bacteria. NADP, nicotinamide adenine dinucleotide phosphate; ATP, adenosine triphosphate.

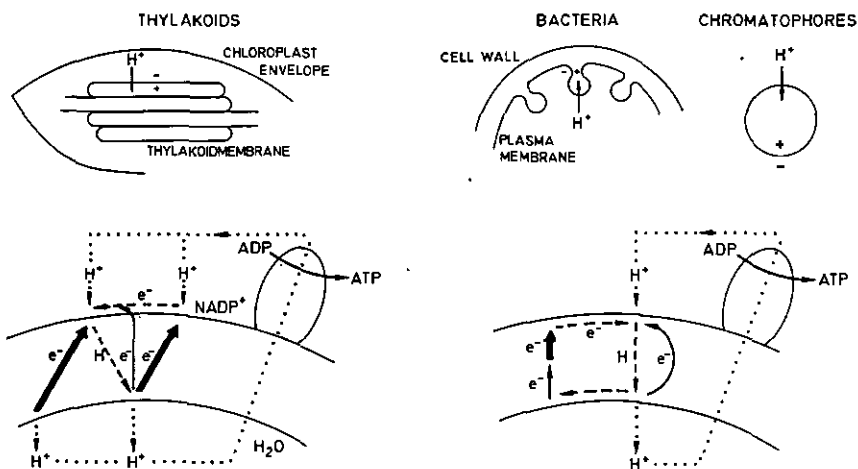

FIG. 2. Schematic representation of thylakoids, bacteria, and chromatophores and of the gross topology for electron transport and proton fluxes. Key: \uparrow , electrogenic reaction (rapid, photochemical); \uparrow , electrogenic reaction (slower, thermally activated); \uparrow , nonelectrogenic electron and hydrogen transfer; \uparrow , proton pathways.

of several species of photosynthetic bacteria is invaginated to form an extensive intracytoplasmic membrane, which upon mechanical disruption, breaks up into small (36–60 nm diameter) closed vesicles, the chromatophores which catalyze an active, light-driven, cyclic electron transport/phosphorylation. The chromatophore is topologically inverted with respect to the bacterial plasma membrane. The directionality of proton pumping and the electric polarity is the same in thylakoids and in chromatophores. It is opposite to that in the plasma membrane of bacteria. This is illustrated in Fig. 2.

In both thylakoids and chromatophores, light is absorbed by chlorophylls (Chl or BChl) and carotenoids (Car) which act as antennae for the photochemical reaction centers (RCs). In thylakoids, two RCs participate in linear electron transport from water to NADP^+ . (For details, consult Okamura *et al.*, Chapter 5; Parson and Ke, Chapter 8; and Cramer and Crofts, Chapter 9, this volume.) In both of the thylakoid RCs (but not in bacterial RCs), the very rapid photochemically driven electron transport reaction fully transverses the membrane dielectric, and rapidly generates the electric potential difference. In some conditions a third, much slower electrogenic reaction operates during a cyclic electron transfer around photosystem I (PSI). In chromatophores a single RC is responsible for driving electrons around a cycle of carriers. The rapid photochemical electron transfer only partially crosses the membrane dielectric. The crossing is then completed by another elec-

tron transport step. A second crossing of the dielectric is made during a subsequent, slower electron transport reaction in the cycle. Both crossings contribute to the electrical charging of the membrane. These properties are visualized in the lower part of Fig. 2.

Proton uptake at the outer side of the membrane and proton release into the interior of the vesicles are consecutive to the redox reactions. Proton transfer across the membrane is nonelectrogenic, since it is always associated with electron transfer (i.e., it is really H transport). Protonation–deprotonation reactions are inevitably linked to certain redox reactions (of water, NADP⁺, and plastoquinone in green plants and to ubiquinone in bacteria). However, there is some evidence for proteins as intermediate, intramembrane proton donors (and acceptors) for the preceding redox components.

In both thylakoids and chromatophores, inwardly directed proton translocation, which is indirectly electrogenic (via electron transport) causes the outwardly directed motion of other cations and the inwardly directed motion of anions. The steady state values for the electric potential difference and for the pH difference between the bulk phases are: 10 mV plus 3–4 pH units in thylakoids and 200 mV plus 1–2 pH units in chromatophores.

The measurement of membrane potential and of the proton concentration inside thylakoids and chromatophores is difficult, mainly due to the small dimensions of the vesicles. However, several different techniques have been devised which provide both high sensitivity and high time resolution. Only in exceptional cases can microelectrodes be inserted to measure directly the potential difference. Macroscopic electrodes have been used for detecting a charge imbalance in a whole suspension of thylakoids. However, most of the information on electrogenic events in photosynthetic membranes stems from flash spectrophotometry with the electrochromic effects of intrinsic pigments (e.g., Car) serving as a molecular voltmeter of formidable sensitivity and time resolution. This approach has been complemented by the use of extrinsic distribution probes which are measured via fluorescence, radioactivity, or electron spin.

Protonation–deprotonation reactions at both sides of the membrane have been time resolved by means of extrinsic pH-indicating dyes. The steady state figures were obtained mainly by distribution probes, again detectable via fluorescence, radioactivity or spin labelling.

In the following we review the techniques for measuring the electric potential differences and then describe the mechanisms of electric potential generation. This is followed by a brief description of the protolytic reaction steps including a review of the relevant measuring techniques.

The topics of this chapter have been reviewed previously and the interested reader may also consult the following articles: Witt (1971, 1975, 1979), Vredenberg (1976), Hauska and Trebst (1977), Junge (1977b, 1981), and Wraight *et al.* (1978).

II. The Membrane

A. Vesicle Size and Shape

In intact mature chloroplasts, the larger part of the thylakoid membrane is disk-shaped with a typical diameter of 500 nm, an apparent membrane thickness of some 7 nm, and an enclosed internal aqueous phase which appears 10–20 nm thick in the electron microscope (see Mühlethaler, 1977). Calculations based on distribution studies (specific inner volume 3.3 liters/mole Chl; Heldt *et al.*, 1973) and on estimates for the average membrane area per Chl (2.2 nm²; Wolken and Schwertz, 1953; Thomas *et al.*, 1956) yield values for the thickness of the internal aqueous phase of only 5 nm. In isolated, broken chloroplasts the shape and the internal volume of thylakoids are highly variable depending on the salt composition and on the osmolarity of the suspending medium. The variation of the water accessible (internal) volume ranges from 10–80 liters/mole Chl (Gaensslen and McCarty, 1971; Rottenberg *et al.*, 1972; Ort *et al.*, 1976). This corresponds to a thickness of 15–120 nm if the disk shape is conserved.

Electron micrographs of photosynthetically grown intact cells of *Rhodospseudomonas (Rp.) sphaeroides*, *Rp. capsulata*, *Rhodospirillum (Rs.) rubrum* and *Chromatium (Chr.) vinosum* (the popular photosynthetic bacteria of bioenergeticists) reveal a complex network of intracytoplasmic membrane. It is generally believed that the intracytoplasmic membrane is an invagination of the plasma membrane and that during mechanical disruption of the cells it becomes "pinched off" to form the chromatophore vesicles (see Niederman and Gibson, 1978). Chromatophore size may vary slightly with species and method of preparation but they are usually flattened spheres of about 40 nm diameter. The internal space, based on electron micrograph data is about 22 liters/mole BChl which compares with osmotic space measurements of 34–150 liters/mole (Casadio *et al.*, 1974; Michels and Konings, 1978; also see Ferguson *et al.*, 1979).

B. Electrochemical Parameters

1. A SIMPLE MEMBRANE MODEL

For much of the electrochemical behavior of thylakoids and chromatophores it is sufficient to consider the membranes as closed shells

which separate an inner from an outer aqueous bulk phase. By analogy with lipid bilayer membranes the dielectric core of the membrane may be some 5 nm thick.

The most important refinement of this model acknowledges that the membrane interfaces are negatively charged. The negative charges give rise to a surface potential at each interface and electrostatic effects extending out into the aqueous phases on either side of the membrane. Five compartments are therefore considered: bulk water/interface/membrane core/interface/bulk water.

Due to the high mobility of ions in water it is generally considered that the electrochemical potential of any ion ($\bar{\mu}_i = \bar{\mu}_i^0 + RT \ln a_i + z_i F \psi$, where, $\bar{\mu}_i$ is the electrochemical potential of the ionic species i , a_i is the activity of the respective ion, z_i its valency, ψ the electric potential) is constant throughout the interface and bulk phase. Because of the surface charges, the aqueous phases are not of course electrically isopotential. The assumption of constant electrochemical potential will be invalid for transport processes which are fast compared to ionic motion in water. This assumption has been challenged for the internal phase of thylakoids and chromatophores during photophosphorylation (e.g., Kell, 1979). This challenge will be considered later.

Ultimately the five compartment model of membrane vesicles may prove to be inadequate. The protein content of thylakoid (see Thornber and Barber, 1979) and chromatophore membranes (see Niederman and Gibson, 1978) is high so that both the membrane dielectric and the surface charge density may be very granular. The local heterogeneity will probably not be blurred out by rapid lateral diffusion of the charge carriers. Although proteins such as the coupling factor for photophosphorylation (CF_1) appear to be mobile over the surface of thylakoids (Berzborn *et al.*, 1974; Miller and Staehlin, 1976), recent time resolution of its rotational diffusion yielded correlation times of the order of a millisecond (Wagner and Junge, 1980) suggesting a complex formation between several larger proteins.

The thylakoid membrane is also complex in the direction normal to the plane. There are two types of experiments suggesting subspaces within the membrane that may be electrochemically relevant: Proton uptake has been observed to occur from a subcompartment at the outer side of the membrane which is shielded by a (proteinaceous) barrier against the outer bulk phase (Ausländer and Junge, 1974). Also, an impermeant amphiphilic spin probe has been found to accumulate in a subspace within the membrane which is only weakly influenced by the diffuse ionic double layer (Quintanilha and Packer, 1978). Observations on rapid H^+ binding to chromatophore membranes do not appear to be complicated by extra compartments (e.g., see Petty *et al.*, 1979).

2. SURFACE POTENTIALS

The surface charge density inside and outside thylakoid membranes has been estimated by various indirect techniques. Reported figures vary between -1 and $3 \mu\text{C cm}^{-2}$ at physiological pH (for a comprehensive review, see Rumberg and Muhle; 1976; Searle *et al.*, 1977; Itoh, 1978, 1979; Huber *et al.*, 1980; Barber, 1980). This is equivalent to one electronic charge per 16 and 5.3 nm^2 . In chromatophores higher figures ($3\text{--}4 \mu\text{C cm}^{-2}$) have been observed (Case and Parson, 1973a; Matsuura *et al.*, 1979). If the vesicles are suspended in a 10 mM KCl solution then the Gouy-Chapman theory predicts surface potentials as high as 10 ($1 \mu\text{C cm}^{-2}$) and 80 mV ($4 \mu\text{C cm}^{-2}$). The reach of the electrostatic effects from the membrane surface into the aqueous phase is limited by the thickness of the diffuse ionic double layer, which depends on the ionic strength of the medium. It is 1 , 3 , and 10 nm for a $1:1$ electrolyte like KCl at a concentration of 100 , 10 , and 1 mM respectively (for a review, see McLaughlin, 1977). Note that the description of the internal phase as a bulk phase will be more accurate the higher the salt concentration (which reduces the Debye length and the magnitude of the surface potential) and the greater the internal volume. In intact chloroplasts, where the thickness of the internal aqueous phase may be less than 5 nm , this phase is "surface" and a descriptive model analogous to polyelectrolytes may be more appropriate.

Titration of the fixed charges has revealed isoelectric points of thylakoids between pH 4.3 and 5 (Mercer *et al.*, 1955; Mills and Barber, 1975; Itoh, 1978; Åkerlund *et al.*, 1979; Huber *et al.*, 1980) and of chromatophores around pH 5.2 (Case and Parson, 1973a).

3. ELECTRIC CAPACITANCE

The capacitance determines the magnitude of the electric potential difference achieved by the translocation of a certain number of charges ($\Delta\psi \approx \Delta Q/C$). The major contributor is the dielectric core of the membrane, supposedly formed by the tails of lipids and the hydrophobic portions of membrane proteins. The contribution of the diffuse double layers is expected to be negligible (see Feldberg and Delgado, 1978). By analogy with bimolecular lipid membranes, the specific capacitance of thylakoid and chromatophore membranes should be around $0.5\text{--}1 \mu\text{F cm}^{-2}$ (Feldberg and Delgado, 1978). A value of $1.1 \mu\text{F cm}^{-2}$ was estimated from the chromatophore electrochromic absorption changes (Packham *et al.*, 1978). A specific capacitance of $2 \mu\text{F cm}^{-2}$ was inferred from electric studies with extremely swollen thylakoids, so called "blebs" (de Grooth *et al.*, 1980).

4. BUFFERING CAPACITY FOR PROTONS

In the pH range from 6.5 to 9, the specific buffering capacity of the internal space of thylakoids is almost constant, some $0.1 \text{ mole H}^+ (\text{mole Chl})^{-1} \text{ pH}^{-1}$ (Junge *et al.*, 1979; but see also Haraux and de Kouchkovsky, 1979). This implies the involvement of proteins which carry a large number of buffering groups with different pK values. At lower pH, the buffering capacity increases, possibly due to phospholipids with their pK below 5 (Reinwald, 1970; Walz *et al.*, 1974). The specific buffering capacity at the outer side of the thylakoid membrane exceeds the one inside by a factor of >3 (Walz *et al.*, 1974).

Analogous investigations into the pH buffering capacity of chromatophore membranes have not been carried out. Since during the preparation of chromatophores, the lumen of the vesicles becomes filled with the suspending medium, the internal buffering capacity probably depends on the composition of that medium. This assumption was made by Michels and Konings (1978) in their estimation of light-driven ΔpH from measurements of the external pH change. It may however be unwise to neglect the buffering capacity of the membrane itself.

5. RESISTANCE

The resistance of artificial lipid bilayers is very high—up to $10^9 \text{ ohm}\cdot\text{cm}^2$ (see Jain, 1972). The current-voltage relationship may be ohmic up to at least 60 mV. The resistance of natural membranes is generally lower and deviations from Ohm's Law are to be expected. Junge and Schmid (1971) described how the thylakoid resistance could be estimated from the decay of the electrochromic pigment shift after a short flash. The value is approximately 10^4 – $10^5 \text{ ohm}\cdot\text{cm}^2$ (Schmid and Junge, 1975) and for chromatophores $1.5 \times 10^6 \text{ ohm}\cdot\text{cm}^2$ (e.g., from Packham *et al.*, 1980a). In both cases, the resistance may be decreased by several orders of magnitude by addition of ionophorous antibiotics. Simple analysis does not yield linear current-voltage relationships. This may conceivably be due to either nonhomogeneous membrane preparations, voltage-dependent channels/ion carriers (Junge, 1970), or electron transport back reactions (Packham *et al.*, 1980a).

6. INHOMOGENEITY OF MEMBRANE VESICLES

Many of the electrochemical parameters discussed in this chapter depend rather critically on the homogeneity of the membrane preparations. Inhomogeneity of different kinds may affect experimental data in different ways. For instance, minor populations of vesicles with the "wrong" membrane polarity (right-side out/inside out) may give rise to

erroneous estimates of membrane potential and ΔpH (overestimates of membrane potential from electrochromism using diffusion potential calibration—see Section III,B—and underestimates from ion distribution techniques—see Section III,D). Our understanding of the kinetics of electrochemical gradient generation and dissipation may be confused if some vesicles in the populations are damaged or leaky. An analysis of the multiphasic decay of electrochromic absorption changes in a non-homogeneous thylakoid suspension was presented by Schmid and Junge (1975).

III. Measurement of the Membrane Potential

Most of the information on membrane potentials in photosynthesis has resulted from optical techniques via the electrochromic absorption changes of bulk pigments. These absorption changes reflect electric field transients at sites in the membrane where these pigments are located. The field strength depends on both the electric potential difference between the bulk phases and the difference between the surface potentials at either side of the membrane. In a similar way, extrinsic “probes for membrane potentials” react to potential differences between bulk phases but also between bulk phases and interfaces. Permeant ions acting as distribution probes reflect some average of the electric potential in the relatively thin internal phase, which can be different from the bulk potential especially in osmotically contracted thylakoids. The term *membrane potential* is often (not only in the following) used in a sloppy way. We will present a finer discrimination between the potential difference existing across the membrane and the potential difference existing between the bulk phases in Section IV. This chapter overviews the techniques for measuring the “membrane potential” and reviews the evidence and controls.

A. Electrodes

Fowler and Kok (1974b) introduced a technique to record the voltage induced by light flash excitation of a thylakoid suspension with macroscopic electrodes. This method was thought to record those voltage transients across the thylakoid membrane which occurred more rapidly than charge displacement around thylakoids (Witt and Zickler, 1973). The rationale behind the experiments was the following: If a suspension of swollen thylakoids was illuminated with a flash of light at nonsaturating intensity, those parts of a thylakoid which were nearer to the light

source shaded parts which were farther away (by about 1%). This created a greater extent of charge separation on the near-flash side of the vesicles, noncompensation of oppositely directed dipoles, and, therefore an electric imbalance in the suspension in the direction of the light path. This was detectable by macroscopic electrodes. By combining this technique with the electrochromic method, Witt and Zickler (1973, 1974) found a linear relation between the two types of signals which supposedly indicated the transmembrane electric potential difference. However, the electrode technique alone could not prove the existence of a "transmembrane" voltage transient. Becker *et al.* (1978) provided convincing arguments for their proposal that the above described photovoltages resulted from lateral motion of charge carriers along the thylakoid membrane (i.e., a Dember effect). The argument was furthermore corroborated by Trissl *et al.* (1982) who showed that very different types of photovoltages were observed depending on the excitation conditions. Under excitation with a light flash from a discharge lamp (as in the work of the preceding authors) polarity, apparent source capacitance and kinetics of the photovoltage differed from the photovoltage which was evoked under excitation with a pico-to-nanosecond laser flash. In the latter case an instrument limited rise-time (10–90%) of the photovoltage of 200 psec was observed both with thylakoids and with bacterial chromatophores. Under the assumption that the very fast photovoltage reflected the transmembrane charge separation, the distances (weighted by local dielectric constant) between the very primary electron carriers could be inferred. It came out that bacteriopheophytin *a* is at about one third of the distance between P870 and Q_1 ($= Q_A$) in the bacterial RC (Trissl *et al.*, 1983).

Microelectrodes have been used to record voltage transients from the giant chloroplast of *Peperomia metallica* (Vredenberg and Tonk, 1975; Bulychev *et al.*, 1976; Bulychev and Vredenberg, 1976). Although the tip radii of the electrodes were of the same magnitude as the thylakoid vesicles there was good evidence that the impalement did not cause total rupture of the thylakoid membrane. The membrane conductivity seemed higher than in unimpaled thylakoids, but the effects of ion transporting antibiotics were still visible.

Recently, thylakoid membranes have been spread across a hexane–water interface. Although it seems likely that the membrane and RC structure may be impaired by this procedure, the vectorial properties should nevertheless be apparent. Trissl (1980) and Trissl and Gräber (1980) have observed rapid photovoltages across such interfaces via macroscopic capacitive electrodes. The major advantage of this technique is its very good signal-to-noise ratio at high time resolution. On the other hand this technique applies only to an artificial layer structure.

B. Electrochromism in Thylakoids and Chromatophores

1. PRINCIPLE

The thylakoid and chromatophore membranes are highly pigmented. Detection of voltages across these membranes has been possible by spectrophotometric techniques via electrochromic absorption changes. The term *electrochromism* describes the influence of strong electric fields on the absorption spectra of pigments. The major effect is an almost homogeneous shift of an absorption band, typically ~ 0.1 nm for field strengths of about 10^7 V m $^{-1}$. Such field strengths are not uncommon in biological membranes (100 mV across 10 nm yields 10^7 V m $^{-1}$). The physical basis for electrochromic absorption changes is illustrated in Fig. 3 (for theoretical descriptions, see Liptay, 1969, and Reich and Sewe, 1977).

Transients of the voltage cause transient absorption changes (see Fig. 3). Since the wavelength shift is small in comparison with the bandwidth of the pigments, the extent of the electrochromic absorption changes is very small and often difficult to measure. So far this technique has therefore been useful only with the highly pigmented, photosynthetic membranes. There have been some attempts to design electrochromic extrinsic dyes for use with other natural membranes (see Waggoner, 1976) but most useful extrinsic probes appear to respond through a change in distribution and binding and therefore are rather slow (see Section III,C). In contrast, the electrochromic effects in chloroplasts and

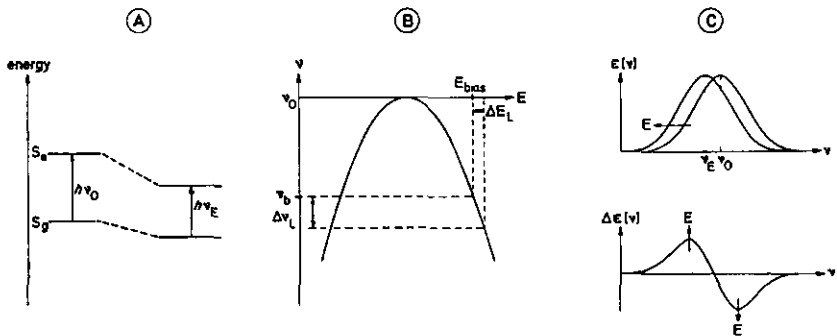

FIG. 3. Electrochromism, the influence of high electric field strength on the absorption spectrum of a dye. (A) Shifts of the energy of the excited (subscript e) and of the ground state (subscript g) of a dye, and the consequent modification of the resonant frequency for light absorption (ν_0 changed into ν_E); (B) Dependency of the resonant frequency on the electric field strength (E). It is assumed that second-order effects prevail. If the dye is exposed to a strong biasing field, the second order dependence may become pseudofirst order with respect to the smaller variable component (ΔE_L); (C) The electrochromic band shift (above) and its difference spectrum (below) (from Junge, 1977a).

chromatophores arise mainly from the electric polarizability of the pigments and should follow transients in the electric field strength without measurable delay.

Initially, the obvious advantages of electrochromic effects were partly offset by the difficulties in discriminating between electrochromic absorption changes and those from other sources. The cumulated evidence from several independent approaches for the existence of electrochromism in photosynthetic membranes is outlined in the following section.

2. KINETICS

Junge and Witt (1968) observed that some absorption changes which appeared when chloroplasts were excited by flashing light decayed faster after manipulations known to increase the ionic conductivity of biological membranes (e.g., ageing, osmotic shock, treatment with solvents, and ion transporting antibiotics). There was no specificity for any ion except for the one introduced by an ion-specific antibiotic. An illustration of the rapid rise, the accelerated decay and the ion specificity of such absorption changes is illustrated in Fig. 4. It was also observed that just one molecule of gramicidin per 10^5 Chls (roughly equivalent to one thylakoid) was sufficient to produce a minimal acceleration of the decay. This suggested that the conductivity-sensitive absorption changes indicated an electric field that was spread out over a whole thylakoid. The rise of the absorption changes was interpreted as the electric charging of the thylakoid membrane and the decay of the discharge via ionic currents.

Similar conductivity-sensitive absorption changes were observed in chromatophores (Jackson and Crofts, 1969, 1971). In these membranes, one molecule of valinomycin per 5×10^3 BChl molecules (again equivalent to one vesicle) produced a measurable acceleration of the decay (Saphon *et al.*, 1975a) (see Fig. 4).

3. SPECTRA

The spectrum of the absorption changes sensitive to the ionic conductivity of the thylakoid membrane is illustrated in Fig. 5 (Emrich *et al.*, 1969; see also Amesz and de Groot, 1975, 1976). It was later found that this complicated spectrum can be approximately synthesized from the electrochromic difference spectra of isolated Cars and Chls, measured in microcapacitors (Schmidt *et al.*, 1970). A similar reconstruction in the Car region of the spectrum was even more accurate for chromatophore absorption changes.

It has become increasingly clear that only a small fraction of the total

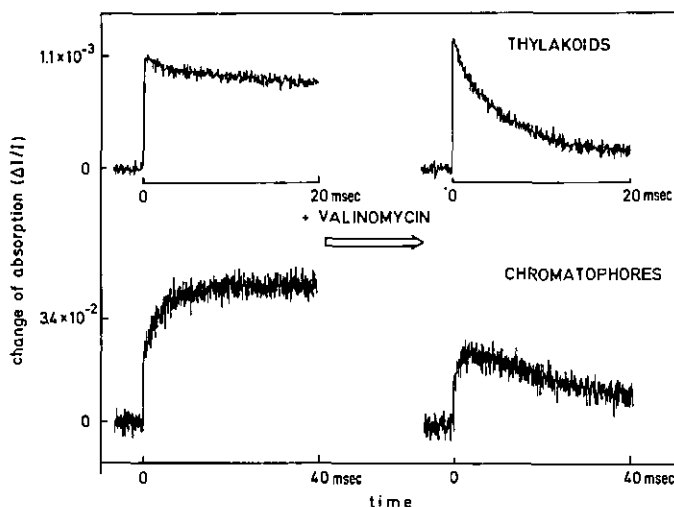

FIG. 4. The decay of the flash light-induced electrochromic absorption changes is accelerated by the K^+ -specific ionophore valinomycin, both in thylakoids (above) and in chromatophores (below). Thylakoids: Chl, $10 \mu M$; KCl, $11 mM$; valinomycin, if present, $11 nM$. Chromatophores: BChl, $11 \mu M$; KCl, $30 mM$; valinomycin, if present, $300 nM$.

Car pool in the membranes was electrochromically sensitive. This conclusion was reached following detailed spectral analysis in chromatophores (de Grooth and Ames, 1977b; Symons *et al.*, 1977) and chloroplasts (de Grooth *et al.*, 1980; Schlodder and Witt, 1980). Experiments suggested that the sensitive Car in chromatophores was associated with one of the two light-harvesting, pigment-protein complexes (LHII or B800-850). When LHII was selectively removed or damaged, either by mutation (Zannoni and Marrs, 1978) or by pronase treatment (Webster *et al.*, 1980) or by bacterial culture at high light intensity (Holmes *et al.*, 1980; Matsuura *et al.*, 1980), a long wavelength absorbing species was lost and electrochromic absorption changes were not detectable.

In thylakoids, the sensitive Cars were associated mainly with the PSII complex. This has been inferred from the involvement of Chl *b* (see later) and indirectly from the low temperature behavior of electrochromic effects (Conjeaud *et al.*, 1976).

The red-shifted, electrochromically sensitive Car may arise from complex formation with neighboring Chl molecules, for instance, in thylakoids between lutein with Chl *b* (Sewe and Reich, 1977). The constant, background polarization of the Car by the Chl not only increases the magnitude of the electrochromic response but also produces a pseudo-linear relation between the absorption change and the electric field transient (see middle of Fig. 3). The linearity of the electrochromic absorp-

tion change in both thylakoids and chromatophores has been established by several independent techniques (Reinwald *et al.*, 1968; Jackson and Crofts, 1969; Witt and Zickler, 1974; Amesz and de Groot, 1975; Schapendonk and Vredenberg, 1977).

Simple electrochromic theory (Reich and Sewe, 1977) predicts that the pigment absorption peaks should shift progressively along the wavelength axis with increasing field strengths (but see Conjeaud and Michel-Villaz, 1976, for further discussion). The wavelength shift is expected to be small and in two sets of experiments with chromatophores, it was not detected (Holmes and Crofts, 1977a, b; Dijkema *et al.*, 1980). However, de Groot and Amesz (1977a, b) after cooling their chromatophore suspension to -35°C and promoting the electron transport reactions with redox dyes, were able to observe a clear shift of about 2 nm. Also, Symons *et al.* (1977) by assuming that only a small fraction of the Car pool was electrochromically sensitive (see earlier), measured a shift of about 1 nm even at room temperature and therefore confirmed the simple predictions of the theory.

4. ARTIFICIALLY INDUCED DIFFUSION POTENTIALS

In bacterial chromatophores electrochromic absorption changes were most convincingly demonstrated by exposing the vesicles to a salt jump in the presence of a cation specific ionophore (Jackson and Crofts, 1969). The extent of the resulting absorption changes was linearly related to the calculated extent of the diffusion potential (Nernst-Planck). Similar attempts with thylakoids were hampered by the more pronounced light-scattering changes of (the much larger) thylakoids (Strichartz and Chance, 1972). It was later possible to control light-scattering transients and observe salt jump-induced absorption changes with the

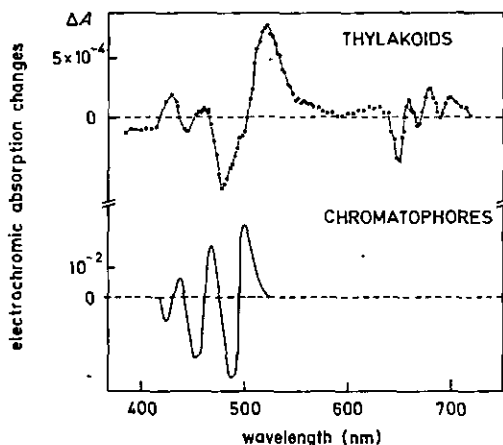

FIG. 5. Difference spectrum of the light-induced electrochromic absorption changes in thylakoids (above, Emrich *et al.*, 1969) and in chromatophores (below, Symons, 1980). The difference spectra were obtained by a point-by-point analysis. Electrochromic absorption changes were discriminated against those of other origin by their sensitivity to ionophores (see Fig. 4).

above spectral properties (Schapendonk and Vredenberg, 1977). Again the expected (Nernst-Planck) linear relation between the diffusion potential and the ratio of the ion concentration was observed. This technique also yielded a calibration of the flash-induced electrochromic absorption changes (see later).

5. ALTERNATIVE, MEMBRANE-LOCATED H^+ TRANSLOCATORS

When strains of the Rhodospirillaceae are grown anaerobically in the light, they develop both a photosynthetic and a respiratory electron transport chain. The respiratory chain also behaves as a proton translocator with the same polarity as the photosynthetic chain (Scholes *et al.*, 1969). Periods of respiration in the dark give rise to a red shift in the Car absorption spectrum (Chance and Smith, 1955).

Chromatophores from *Rs. rubrum* possess an ATPase and a pyrophosphatase, which, when operating in the hydrolytic direction in dark suspensions, pump H^+ inwards and generate electrochromic absorption changes (Baltscheffsky, 1967).

6. EXTERNALLY APPLIED VOLTAGE PULSES

Thylakoid membranes when suspended in a medium of low osmolarity and low ionic strength swell to form large vesicles, "blebs" (diameter 3–5 μm). The large size of these blebs is a consequence of the interconnection between the much smaller thylakoids (in grana stacks). When large vesicles are exposed to an electric field in the suspending medium, a large fraction of the voltage drop will occur across their membranes. The field strength in the membrane may exceed the field strength in the suspending medium by three orders of magnitude (10^8 compared to 10^5 V m^{-1}). De Grooth *et al.* (1980) and Schlodder and Witt (1980) have induced electrochromic absorption changes by exposing blebs to voltage pulses. In contrast to the light-driven membrane voltage where the polarity is always positive inside, the externally induced voltage drop is outwardly directed in 50% of the membrane area and inwardly directed in the other 50%. The linear and pseudolinear effects cancel in the observed ensemble, while the quadratic effects remain visible. Therefore, this technique rather complements the studies of light-induced electrochromism. The sets of responsive Cars and Chls differ in both cases. For this and other reasons (mainly ill-defined geometrical factors) the externally applied voltage pulse technique cannot be used to calibrate the light-induced voltage jumps. However, it can extend the range of voltages applicable to the thylakoid membrane from about 50 mV (by light) to about 500 mV.

7. LIMITATIONS

The preceding arguments prove the utility of electrochromic absorption changes as pseudolinear indicators of the field strength in thylakoid and chromatophore membranes on very fast time scales. Limitations of this molecular voltmeter arise from the following sources.

Thylakoids undergo drastic changes in their light scattering properties in response to the electrochemical events. Double beam spectrophotometry does not entirely eliminate the problem since the difference spectrum of the apparent absorption changes due to light scattering is rather similar to that of electrochromism (Thorne *et al.*, 1975). Scattering changes are negligible during excitation of chloroplasts with flashing light at low repetition rates but they may have interfered in experiments under prolonged illumination (e.g., Larkum and Bonner, 1972; Strichartz and Chance, 1972; Baltscheffsky and Hall, 1974; Kulandaivelu and Senger, 1976). Chromatophores, on the other hand, do not suffer from light-scattering interference even during continuous illumination because their diameter is much less than the wavelength of the measuring light. Electrochromism therefore may be used reliably for membrane potential determinations even during prolonged periods of illumination.

In the spectral region of the major bands of electrochromism (478 and 518 nm, in thylakoids; and between 460 and 530 nm depending on the species and the strain in chromatophores), there are other superimposed absorption changes. The larger component, appearing at saturating excitation energies, is attributable to Car triplets originating from a reaction that protects the antenna Chls from photo-oxidation (Wolff and Witt, 1969; Mathis, 1970; K. Witt and Wolff, 1970; Cogdell *et al.*, 1975). It may be distinguished from electrochromic absorption changes by its much higher saturation levels and by its more rapid decay. The remaining component, which accounts for about 10% of the flash-induced absorption changes at 518 nm in thylakoids, is partially due to the RC-Chls. In chromatophores the contaminating absorption change is usually rather less than 10% of the total change and is due to both RC BChl (Symons and Crofts, 1980) and a RC Car that is sensitive to local electric fields (Cogdell *et al.*, 1975).

Since the electrochromically sensitive pigments may be localized within discrete protein complexes (see earlier), a transmembrane charge separation that occurs in a remote portion of the membrane will be sensed only if the electric field is distributed over the membrane. Such a charge delocalization will only occur at temperatures where the electric conductivity of the aqueous phases is high enough (for low temperature

studies, see Mathis and Vermeglio, 1974; Vermeglio and Mathis, 1974; Amesz and de Grooth, 1975, 1976; Conjeaud *et al.*, 1976; de Grooth and Amesz, 1977a).

The electrochromic pigments sense the electric field at their particular site within the membrane. As the response is pseudolinear (see earlier), different field strengths at different sites will not complicate the matter. However, the electric field strength within the membrane is not necessarily proportional to the voltage between the two bulk phases. Instead, it is given by the difference between the potentials at the membrane water interfaces. This is the sum of the difference of the bulk potentials and the difference of the surface potentials (e.g., calculated after Gouy-Chapman):

$$E = (\Delta\psi_{\text{bulk}} + \Delta\psi_{\text{surface}}) \times d^{-1}$$

where d is the thickness of the membrane. This complication is negligible in studies on the voltage changes under flashing light. Calculation of the change of the surface potential induced by the translocation of two protons per electron across the thylakoid membrane (single-turnover flash with both photosystems active) yields figures smaller than 2 mV once the concentration of monovalent electrolytes exceeds 3 mM as is usual (it is assumed that the surface charge density is $1 \mu\text{C cm}^{-2}$, see earlier). This is small in comparison with the approximate 50 mV change of the transmembrane potential. However, the difference between the surface potentials may contribute considerably to the field strength under continuous illumination (Witt, 1979; Huber *et al.*, 1980; and later).

C. Extrinsic Voltage Probes

In nonphotosynthetic membranes, the concentration of pigments is too low for the detection of electrochromic responses. Considerable effort has been spent in the development of membrane potential-sensitive extrinsic probes. Those probes which are currently available do not however appear to show electrochromic effects—their response to membrane potential is generally interpreted as being due to a change in binding properties. Experiments with extrinsic probes in photosynthetic tissues have so far been of value for qualitative observations on the development of membrane potential especially for comparison with the intrinsic electrochromic responses.

Oxocarbocyanine shows a fluorescence decrease and a blue absorption band shift in illuminated chromatophore suspensions. Bound probe is released from the membrane during illumination (Pick and Avron,

1976). The oxonols on the other hand show a fluorescence increase in illuminated chromatophores (Bashford *et al.*, 1979a) or thylakoids (Girault and Galmiche, 1980). Moreover the oxonols lead to an accelerated decay of the electrochromic Car shift after flash excitation of chromatophores (Bashford *et al.*, 1979a). Taken with the finding that the absorption spectra of both these dyes are red-shifted when associated with lipid membranes (Sims *et al.*, 1974; Bashford *et al.*, 1979b), the mechanism of the response to membrane can be partly rationalized (Pick and Avron, 1976; Bashford *et al.*, 1979a). Oxocarbocyanine is a permeant cation and will be driven outwards across the chromatophore membrane by the light-induced membrane potential whereas the oxonols are permeant anions and will move inwards (hence their effect on the carotenoid band shift). Since the internal volume of the chromatophores is small compared with the volume of the suspending medium there will be a net decrease in oxocarbocyanine binding to the membrane and a net increase in oxonol binding upon generation of membrane potential.

There are some difficulties to be considered when using these dyes as probes for membrane potential. They are comparatively slow to respond, the spectral changes cannot be directly calibrated, and the dyes have a slight uncoupling effect on phosphorylation.

During its checkered career as a probe for membrane "energization," 1-anilino-8-naphthalene sulphonate (ANS) has been used as an indicator of membrane potential (Gromet-Elhanan, 1972; Leiser and Gromet-Elhanan, 1977). There is a considerable possibility, however, that the ANS response is a composite of several phenomena (see Azzi *et al.*, 1971; Jasaitis *et al.*, 1971; Njus *et al.*, 1977).

D. Ion Redistribution

The equilibrium distribution of a permeable ion (I) between two aqueous phases separated by a membrane is described by the Nernst-Planck relationship

$$\Delta\Psi = -\frac{RT}{ZF} \ln \frac{[I]_{IN}}{[I]_{OUT}}$$

and in principle permits a simple measure of the bulk phase membrane potential. Because the total internal volume of vesicle suspensions is usually very much less (1:1000) than that of the external suspending medium, it is preferable to use, for greater accuracy, an ion which is accumulated by the vesicles. For instance in chloroplasts and chro-

matophores with an internally positive membrane potential under energization, the uptake of a permeant anion is normally measured.

Several ingenious techniques have been developed for the measurement of ion uptake. Historically, microcentrifugation methods were the first to be employed (Rottenberg *et al.*, 1972). Problems of diminishing light intensity during the separation of the vesicles from the suspending medium were partly eliminated using a three-phase centrifugation procedure in which the vesicles are sedimented through a layer of silicone oil (Gaensslen and McCarty, 1972; Portis and McCarty, 1976). These procedures are not well suited to small vesicles such as chromatophores; the use of precipitation reagents such as protamine sulphate (Schuldiner *et al.*, 1974) may alter the permeability of the membranes.

Ion uptake by photosynthetic vesicles has also been estimated by the technique of flow dialysis (Kell *et al.*, 1978a, b; Michels and Konings, 1978; Ferguson *et al.*, 1979). The concentration of the radioactively labeled ion in the vesicle suspension is determined from its rate of diffusion across a dialysis membrane into an adjacent compartment through which fresh buffer is pumped continuously. More direct assay of ion uptake may be achieved using ion exchange electrodes (Kell *et al.*, 1978b) or selectively permeable-membrane electrodes (Isaev *et al.*, 1970; Liberman and Skulachev, 1970; Drachev *et al.*, 1976; Remennikov and Samuilov, 1979).

In all of these methods, the external equilibrium concentration of permeant ion, $[I]_{OUT}$, and the amount of uptake are calculated more or less directly. Estimation of $[I]_{IN}$ requires a value for the internal space of the vesicles and this is normally obtained from the difference in volume occupied by 3H_2O (a total penetrant) in the vesicle suspension and an assumed nonpenetrant such as $[^{14}C]$ sorbitol. It is difficult to achieve high precision in these determinations but inaccuracies are only critical at low values of membrane potential.

Ion distribution methods cannot, of course, be used to monitor rapid membrane potential transients. They can only be employed in conditions approaching a steady state.

E. Delayed Fluorescence

Delayed fluorescence from thylakoids is attributed to the back reaction between the primary electron donor in PSII (P680, a special Chl a) and one of the primary electron acceptors (for reviews, see Lavorel, 1975; Govindjee and Jursinic, 1979). The intensity of delayed fluorescence was found to depend on the magnitude of an artificially induced diffusion potential (Barber and Kraan, 1970; Wraight and Crofts, 1971)

or on the strength of externally applied electric field (Ortoidze *et al.*, 1979). The observed exponential dependence of the fluorescence intensity on the electric potential difference conforms with elementary kinetics. The intensity of delayed fluorescence has been used as an indicator for the magnitude of the voltage across the thylakoid membrane. The usefulness of delayed light emission as a molecular voltmeter is limited because of modulation of the response by the pH difference across the membranes (see Jursinic *et al.*, 1978).

IV. Electrogenic Reactions in Thylakoids and Chromatophores

The proton transfer steps across the membranes of thylakoids and chromatophores are not electrogenic: Protons move together with electrons. The membranes are electrically charged by electron transport. The first and very rapid (sub-nanosecond) electron transfer steps in the respective RC complexes traverse the membrane dielectric, almost completely in thylakoids and by about one-half in chromatophores. These reactions involve the primary electron donors (special Chl *a* and BChl *a*), the intermediate carriers (Chl *a* and pheophytin *a* and their bacterial analogs), and special quinone acceptors. In chromatophores, the remaining half of the dielectric is bridged by electron transfer from Cyt *c* to the BChl pair. In both organelles there is another, slower electrogenic component, which involves *b*-type Cyts. In both organelles the *slow* electrogenic reactions operate at the junction between a two-hydrogen [H] carrier with a one-electron carrier. In thylakoids this reaction is only apparent under conditions, for example, of pseudocyclic electron transfer around PSI.

A. Electrogenic Reactions in Thylakoids

1. ELECTROGENIC STEPS IN THE LINEAR ELECTRON TRANSPORT CHAIN

Both photosystems contribute about equally to the electric potential generated by excitation with a short flash of light (Schliephake *et al.*, 1968; Malkin, 1978) as illustrated in the upper part of Fig. 6. It seems likely that in each photochemical act, an electron is transferred from the donor to the primary acceptors, and it fully crosses the dielectric core of the thylakoid membrane. This is supported by three types of observations: (1) the electrochromic absorption changes are complete in less than 20 nsec after stimulation with a pulse from a Q-switched ruby laser

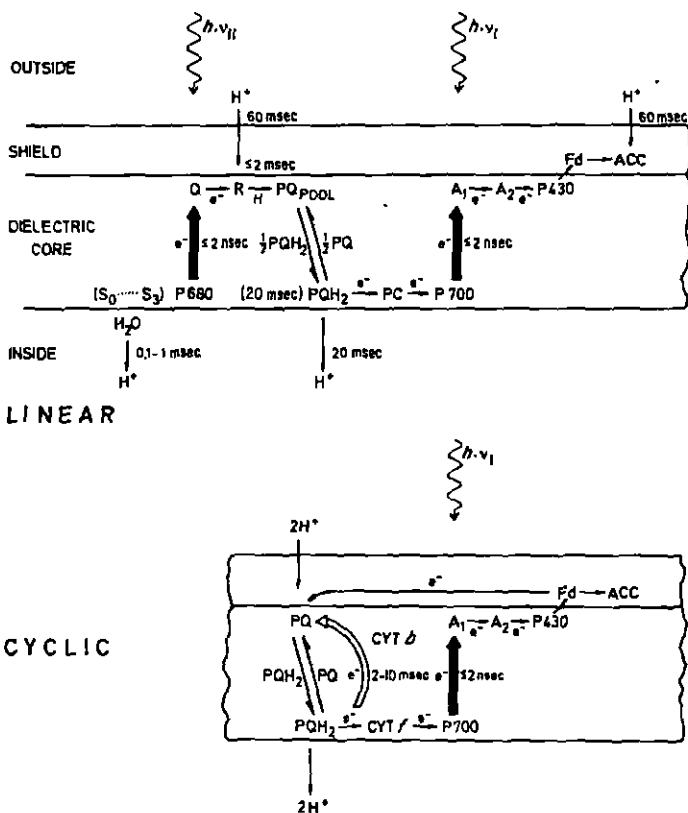

FIG. 6. Topology and kinetics of electrogenic reactions and protolytic reactions in thylakoids (for references, see text). Electrogenic reactions are indicated by wide arrows (filled arrows for the most rapid photochemical steps—open arrows for slower electron transfer steps). Above: Solely linear electron transport as in broken chloroplasts with Hill acceptor. Below: The additional cyclic electron transport which is observed in intact chloroplasts or in freshly broken ones (tentative scheme). (S_0 – S_3), S states involved in O_2 evolution; P680, primary electron donors of PSII; Q, primary quinone acceptor; R (\equiv B), secondary quinone acceptor; PQ, plastoquinone; PC, plastocyanin; P700, primary electron donors of PSI; A_1 , Chl, first electron acceptor of PSI, A_2 , Fe–S center; P430, also an Fe–S center; Fd, ferredoxin; ACC, Hill acceptor; and Cyt *b* (*f*), cytochrome *b* (*f*).

(Wolff *et al.*, 1969); with thylakoid membranes spread at a hexane–water interface, the time for the rise of the voltage has been shown to be less than 200 psec (Trissl *et al.*, 1982); (2) the electric potential can be generated at low temperatures ($\sim 50^\circ\text{C}$) (Amesz and de Grooth, 1975, 1976; Mathis and Vermeglio, 1975) [incidentally, the disappearance of elec-

trochromic absorption changes due to stimulation of PSI alone (Conjeaud *et al.*, 1976), which is observed below -125°C , is probably attributable to hindrance of delocalization of the electric field from PSI where it is generated, to sites around PSII where the electrochromic pigments reside—see Section 11,B,3, and Junge and Schaffernicht, 1977, 1979]; (3) the emission of delayed fluorescence, which is thought to result from the reversal of the photochemical reaction, is sensitive to the electric potential across the thylakoid membrane (Barber and Kraan, 1970; Wraight and Crofts, 1971; Ortoide *et al.*, 1979; however, see Jursinic *et al.*, 1978).

The polarity of the light-generated electric potential is positive inside, most conclusively demonstrated by studies on the redistribution of ions (Deamer and Packer, 1969; Schröder *et al.*, 1972; Hind *et al.*, 1974).

In isolated, broken chloroplasts (especially after storage under liquid nitrogen) no further kinetic components follow these rapid electrochromic absorption changes produced by short flash excitation. In particular there is no component which kinetically matches the reduction kinetics of P700 (Junge, 1972). [Under flashing light the reduction of P700 is multiphasic (half-risetimes 10 μsec , 200 μsec , and some 20 msec), with the first two phases being attributable to electron donation from plastocyanine (PC) and the slowest due to reduction by plastoquinone via plastocyanin (Haehnel and Witt, 1972; Haehnel, 1977; Haehnel *et al.*, 1980; also see Cramer and Crofts, Chapter 9, this volume).] This indicates that other reactions, especially the reduction of P700, are not electrogenic. It is very probable that these electron transfer reactions (but also proton uptake and proton release) occur in an environment with a much higher dielectric constant than that of the membrane core, perhaps in the domain of the lipid head groups at the membrane-water interface.

It follows that P700, the primary electron donor of PSI which was thought to be a pair of Chl *a* molecules, is located near to the internal membrane-water interface. The primary electron acceptors, at least those that are reduced within 200 psec should reside close to the outer membrane-water interface. The first in a row of these acceptors (see Sauer *et al.*, 1978) is possibly (another pair of) Chl *a* which is reduced within less than 60 psec (Shuvalov *et al.*, 1979; also see Chapter 8, this volume). As the present time resolution for the electrochromic and for direct electric measurements does not reach that for measuring electron transfer it is unclear which of the acceptors in the chain resides where in the membrane (but see Trissl *et al.*, 1982, for bacterial RC).

From studies of the emission of delayed fluorescence it was inferred

that one of the later acceptors (in a row at PSII) is at a distance of 25 Å from the primary electron donor in PSII (Ortoidze *et al.*, 1979). The immediate acceptor which was thought responsible for μ sec delayed fluorescence appeared to reside within 0.5 nm of the donor (Jursinic *et al.*, 1978). The donor-acceptor system resides within a protein complex (see Section VI,A).

The probable subunit composition (after Bengis and Nelson, 1975) and the possible arrangement of the primary electron donor pair in PSI will also be illustrated in a later figure (Section VI,A). This figure will also show that at least the y axes of the two Chl *a* rings (Junge and Eckhof, 1974; Breton, 1976) and probably also the x axes (Junge and Schaffernicht, 1979) are only slightly tilted out of the thylakoid membrane (see Breton and Vermeglio, Chapter 4, for details). For the respective y axes, little tilt has also been reported for the special Chls in PSII (Mathis *et al.*, 1976).

It is not clear how the electron is rapidly channeled across the thylakoid membrane, whether, for instance a "molecular wire" of π electron systems is involved (compare Mangel *et al.*, 1975; Kuhn, 1979; Möbius, 1979), or whether the protein interior acts as an injection semiconductor (Tributsch, 1972). These hypotheses remain speculative and have gained no experimental support.

2. ELECTROGENIC STEPS IN CYCLIC ELECTRON TRANSPORT

Isolated chloroplasts with an intact outer membrane carry out cyclic electron transport (driven by PSI but also influenced by PSII) which may serve the purpose of pumping protons for the synthesis of ATP without net NADP reduction (Arnon *et al.*, 1967). With a constant $H^+ : ATP$ ratio (of supposedly 3) and a constant $H^+ : e^-$ ratio for the linear electron transfer chain (for a review, see Junge, 1977b), the NADPH:ATP ratio would be fixed (at a value of 0.75). The cyclic electron transfer enables thylakoids to deliver a higher proportion of ATP when needed by the chloroplast. The ability for cyclic electron transport is lost after damage of the outer membrane and loss of stroma (Arnon *et al.*, 1967).

While isolated chloroplasts with broken outer envelopes reveal a seemingly monophasic and very rapid rise of the electrochromic absorption changes (see Fig. 4; risetime of less than 20 nsec, Wolff *et al.*, 1969), it has been known for many years that algae show an additional slower rising component (a few msec risetime; Witt and Moraw, 1959; Joliot and Delosme, 1974; Bouges-Bocquet, 1980). In algae it is difficult to assign absorption changes at 518 nm unequivocally to electrochromism. Therefore, the possibility of another slower electrogenic reaction step did not find much support until a few years ago. Joliot *et al.* (1977)

reported a new fast rising component (20 μsec) of the absorption changes at 518 nm in isolated chloroplasts. However, this was later attributed to multiple excitation of the RCs by the tail of the exciting flash (Delosme *et al.*, 1978). Then four research groups reported slowly rising components of these absorption changes (risetimes of some msec) in freshly isolated chloroplasts (Velthuys, 1978, 1979; Crowther *et al.*, 1979; Horvath *et al.*, 1979; Slovacek *et al.*, 1979; and Bouges-Bocquet, 1980, in algae). There is very good evidence that these absorption changes are indeed electrochromic and represent another electrogenic step of the electron transport chain.

Common to all research are the following observations: The driving force for the slow electrogenic reaction step is provided by PSI (e.g., Crowther *et al.*, 1979); and the oxidoreduction state of the PQ pool is an important regulator, so that the activity of the slow electrogenic reaction is also controlled by PSII. Although the status of the outer membrane has not received particular attention by Velthuys (1978, 1979), the other groups agree that the slowly rising electrogenic reaction near PSI requires an intact outer membrane, i.e., the availability of soluble ferredoxin plus possibly other stromal cofactors (Crowther *et al.*, 1979; Horvath *et al.*, 1979).

The lower part of Figure 6 is a scheme of events producing the slow electrogenic reactions assembled on the basis of the preceding references. As there is no complete agreement on details among the cited authors, this scheme is tentative. The slow electrogenic reaction is part of an electron-hydrogen loop which is linked to linear electron flow. The inwardly directed hydrogen transfer step of this loop seems to share the PQ pool with the linear electron transport chain. This is *inter alia* expressed in the DBMIB sensitivity of the slow electrogenic reaction (Slovacek *et al.*, 1979). A prerequisite for the slow reaction is that Cyt *f* be reduced (Velthuys, 1978). It seems as if electron donation by the two-electron donor plastoquinol (PQH_2) to the one-electron acceptor Cyt *f* creates the driving force for another one-electron transfer step, probably from plastosemiquinone (PQ^- or PQH) to a *b*-type Cyt. This electron transfer step is outwardly directed and hence it creates a voltage transient across the membrane. Near the outer side of the membrane the electron is again transferred to PQ to yield the semiquinone. Since only the fully reduced and protonated PQ can move inwards across the membrane (literally or by transferring hydrogen via multiple collisions), another electron is required. This may be provided by electron transfer from PSI, involving soluble ferredoxin (a possibility suggested by the experiments of Slovacek *et al.*, 1979). In a blue-green alga it has been observed (Knaff, 1977) that Cyt- b_6 is reduced by ferredoxin and ox-

idized via an ADP-sensitive step (which should also be a proton pumping step involving PQ).

3. THE MAGNITUDE OF THE ELECTRIC POTENTIAL DIFFERENCE IN THYLAKOIDS

a. Excitation with Single Turnover Flashes. The earliest estimate on the magnitude of the electric potential difference was based on certain assumptions on the average area per RC (each translocating one elementary charge) and the electric capacitance of the thylakoid membrane (Schliephake *et al.*, 1968). With 2.2 nm^2 per Chl and 600 Chls per pair of RCs one calculates a voltage of 48 mV for a specific membrane capacitance of $0.5 \mu\text{F cm}^{-2}$ (24 mV for $1 \mu\text{F cm}^{-2}$ and 12 mV for $2 \mu\text{F cm}^{-2}$). The former capacitance is the one measured for a planar lipid bilayer membrane (phosphatidylethanolamine/*n*-decane; Feldberg and Delgado, 1978). There is no reliable estimate for the capacitance of the thylakoid membrane at hand (the value of $2 \mu\text{F cm}^{-2}$ calculated for highly swollen thylakoids ("blebs") may be too high; de Grooth *et al.*, 1980).

An independent measure of the flash-induced electric potential difference was based on microelectrodes inserted into giant chloroplasts of *Peperomia metallica*. While figures of some 10 mV were reported in the earlier work (Vredenberg and Tonk, 1975; Bulychev *et al.*, 1976), a higher value of 40 mV was given in a later paper (Bulychev and Vredenberg, 1976). Zickler *et al.* (1976) argued that impalement damage might have accelerated the breakdown of the electric potential difference and therefore led to an underestimation. This was not likely, so long as the apparent rise of the electric potential after a flash was much faster than the observed decay. However, it could be that an underestimation arose from the finite electrode capacitance which had to be charged in parallel with the membrane capacitance.

Schapendonk and Vredenberg (1977) also attempted to calibrate the light-induced electrochromic absorption changes by comparison with the absorption changes induced by a salt jump in the presence of the ionophore valinomycin [analogous to Jackson's and Crofts' (1969) work with chromatophores]. In contrast to previous attempts with chloroplasts (Gross and Libbey, 1972; Strichartz and Chance, 1972), apparent absorption changes due to transients of light scattering were better controlled in these experiments. The expected Nernst-Planck behavior was observed; changes in surface potential were neglected. The authors calculated a maximum single turnover flash-induced voltage of 58.5 mV which was reduced to 35 mV under certain assumptions on the permeability ratio between K^+ and Cl^- in their experiments. The variation of the voltage among different samples was 15–35 mV.

A much higher estimate for the single turnover voltage was presented by Zickler *et al.* (1976). These authors incorporated the voltage-gated, channel-forming antibiotic alamethicin into thylakoid membranes. Comparing the observed extent of the electrochromic absorption change, where gating occurred, with the known gating voltage from studies with artificial membranes, they proposed a single turnover voltage of 105–135 mV. Jursinic *et al.* (1978) obtained values in the same range from measurements on delayed fluorescence of Chl *a* after single flashes of light. In view of the indirect nature of all these estimates it is difficult to favor one over the other. A figure ranging between 30 mV and 50 mV seems probable. Because the electrochromic absorption changes sense the electric field in the thylakoid membrane they will also detect transients of the surface potential difference. This, however, is expected to be negligible after single turnover flashes (see Section III,B,7).

b. Excitation of Thylakoids with Continuous Light. The reported values for the electric potential difference under saturating steady illumination differed depending on the measuring technique. The potential difference was some +10 mV (positive inside) when measured via the redistribution of permeant ions (Rottenberg *et al.*, 1972; Schröder *et al.*, 1972) or by application of a microelectrode (Bulychev and Vredenberg, 1976). On the other hand it appeared to be one order of magnitude greater (100 mV) when measured via the emission of delayed fluorescence (Barber, 1972) and via the electrochromic absorption changes (Gräber and Witt, 1974). The apparent discrepancy has been interpreted as follows (Rumberg and Muhle, 1976; Rumberg, 1977; Witt, 1979). The first two methods are sensitive to the electric potential difference between the bulk phases (or some average over the bulk phases). In contrast, the latter techniques sense the electric field strength in the membrane. Under the constant field assumption, this is proportional to the transmembrane potential ($\Delta\psi_{tr}$) which is the sum of the bulk potential difference ($\Delta\psi_b$) and the surface potential difference ($\Delta\psi_s$) as illustrated in Fig. 7. While the bulk potential difference is indeed small during steady light, continuous inwardly directed proton pumping may even shift the internal pH to below the isoelectric point of the buffering groups (see Section II,B). Although negative in the dark, the internal surface potential may then become positive in the light. The surface potential difference between the inner and the outer side of the membrane probably makes up for the greater part of the total transmembrane potential difference of 100 mV as detected via electrochromism or delayed light emission under steady illumination. This is illustrated in Fig. 7.

The time course of the generation of the electric potential difference,

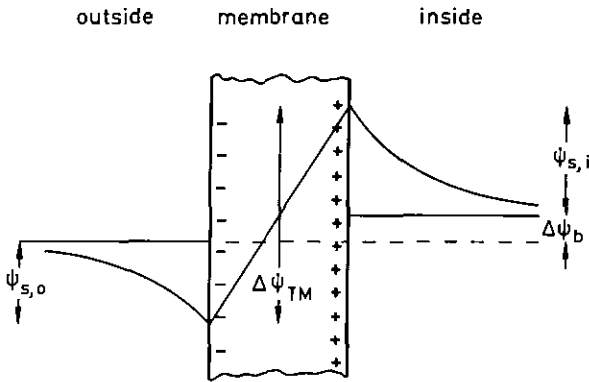

FIG. 7. Schematic drawing of the thylakoid membrane under steady illumination with the electric potentials in the bulk phases (ψ_b), at the surfaces (ψ_s), and the potential difference across the membrane ($\Delta\psi_{TM}$). It was assumed that the internal acidification crossed over the isoelectric point of the thylakoid interior.

estimated from the electrochromic absorption changes, is as follows. After the onset of illumination the electric potential difference rises up to a relatively high level. It reaches between two and four times higher values than under excitation with a single short flash. Under the influence of this electric potential difference, cations move outward and anions inward. As the internal phase becomes more and more acidic, outward proton flux takes over an increasing proportion of the electric current in response to the electric field (see Gräber and Witt, 1976). In the steady state, the proton efflux fully compensates the active, inward proton pumping. The internal acidification feeds back negatively on the velocity of the electron transport. This leads to a decrease of the electric potential toward the steady state.

The magnitude of both the surface potential difference and the bulk potential difference depends on the salt concentration in the medium. We consider first the bulk potential difference. It is generally agreed on that protons are the only actively transported ions in thylakoid membranes and that other ions move passively. When approaching the steady state under continuous illumination these other ions tend to adjust their concentration ratio to the electric potential difference between the bulk phases as described by the Nernst-Planck equation. Thylakoids are moderately permeable to ions (Cl^- , K^+ , Mg^{2+}) that are commonly used in the experimental medium. It is obvious that well-coupled thylakoids under saturating illumination can only maintain a limited value of the electrochemical potential of the proton $\Delta\bar{\mu}_{\text{H}^+}$ ($=\Delta\psi_b - 0.06\Delta\text{pH}$). The limit is determined by the redox span of the proton pumps and their

stoichiometric ratio ($H^+ : e^-$). The practical limit is 250 mV. The internal buffering capacity of the thylakoids also limits the net uptake of protons during steady illumination ($\leq 0.5 H^+ / Chl$). The total number of equivalents passively redistributed (other ions) can only fall short of this number.

For illustrative purposes we assume that K^+ is the only permeant species. At bulk concentrations below 100 mM this ion is probably not buffered in the thylakoid interior. If it were possible to carry out an experiment at exceedingly low K^+ concentrations (e.g., $10^{-5} M$), a net uptake of $0.5 H^+ / Chl$ would not be electrically compensated by an equivalent K^+ extrusion. Under these conditions a relatively high electric potential and a relatively low pH difference would be expected. Under more realistic conditions (i.e., 30 mM KCl in the medium) the extrusion of 10 mM K^+ (which is equivalent to $0.5 K^+ / Chl$ at an internal volume of 50 liter/mole Chl) corresponds to a Nernst-Planck potential of only 10 mV. This is the maximum possible potential difference between the bulk phases under these conditions. It is apparent that the bulk potential difference is small at reasonably high salt concentrations.

The difference of the surface potentials as a function of the salt concentration has been estimated by Huber *et al.* (1980). These authors have applied a modified version of the Gouy-Chapman theory (adapted to allow for some granularity of the surface charge distribution). They calculated the following behavior of the surface potential difference on the KCl concentration: When the KCl concentration is increased to above 1 mM, the potential difference increases up to a maximum of 60 mV at 6 mM KCl and subsequently falls rapidly to below 10 mV (at 30 mM KCl) at higher salt concentrations. This qualitatively agreed with the behavior which was experimentally observed via the electrochromic absorption changes.

It seems as if the electric part of the bulk phase electrochemical potential difference of the proton, although dominant under flashing light and in the initial phase of continuous illumination, plays no essential role in the steady state under continuous illumination.

B. Electrogenic Reaction Steps in Chromatophores

1. ELECTROGENIC STEPS IN CYCLIC ELECTRON TRANSPORT

Although in some circumstances a linear, light-driven electron transport chain using oxygen as acceptor can operate in bacterial chromatophores (Zannoni *et al.*, 1978), under most conditions the electron transport reactions function as a closed cycle (see Prince and Dutton, 1975). The photosynthetic RCs serve to oxidize a *c*-type Cyt and to

reduce UQ. At optimal redox poise electron cycling from UQ to Cyt *c* then takes place through the Cyt *b/c*₂ complex and is complete within tens of milliseconds. Two electrogenic reactions in the electron transport chain have been identified from electrochromic absorption changes.

The kinetics of the chromatophore electron transport reactions are profoundly influenced by the ambient redox potential. The cycle operates at its maximum rate at $E\%_m = 100$ mV, pH 7.0. After single turn-over flash activation of *Rp. sphaeroides* and *Rp. capsulata* chromatophores under these conditions, three phases of the electrochromic shift can be distinguished (Jackson and Dutton, 1973). Phase I accounts for approximately 25%, phase II 25%, and phase III 50% of the total absorption change. Phase I is very rapid ($t_{1/2} < 50$ nsec, Jackson and Crofts, 1971) and is abolished when either the primary UQ is chemically reduced or when RC BChl special dimer, [BChl]₂, is chemically oxidized before the flash. Phase I may be observed at low temperatures (de Grooth and Amesz, 1977a). The redox potential dependence, the temperature dependence, and the kinetics associate phase I with the reaction [BChl]₂ → UQ_I. Phase II (generated within 100 μsec) has similar kinetic characteristics and a similar redox potential dependence to the reaction Cyt *c*₂ → [BChl]₂⁺ (Dutton *et al.*, 1975) and is missing in mutants lacking Cyt *c*₂ (Zannoni *et al.*, 1980). Phase III, by similar criteria, correlates with the reactions involving the re-reduction of Cyt *c*₂ by Cyt *b*. At optimal redox poise, phase III has a half-time of about 2 msec. This reaction is specifically antimycin sensitive (Jackson and Dutton, 1973; Bashford *et al.*, 1979c; van den Berg *et al.*, 1979).

These details have been rationalized in terms of the model shown in Fig. 8. Two transmembrane passages of electron transport are envisaged. One of them, Cyt *c*₂ → [BChl]₂ → UQ_I, gives rise to phases I + II; the other, probably the oxidation of a *b*-type Cyt, generates phase III. The transfer of electrically neutral reducing equivalents (e.g., H atoms) between the two electrogenic reactions almost certainly proceeds by way of UQ (Baccarini-Melandri and Melandri, 1977; Bowyer *et al.*, 1978; Takamiya *et al.*, 1979) and may involve either a "linear" loop (Mitchell, 1966) or a Q cycle (Mitchell, 1976) (see Cramer and Crofts, Chapter 9, this volume). Each electrogenic reaction contributes equally to the membrane potential (phase I + II = phase III) because the same amount of charge is transported across the same membrane dielectric.

Since, in contrast with the situation in thylakoids, the first electrogenic process has two component reactions (corresponding to phases I and II), the RC BChl must be located toward the center of the membrane dielectric. The equilibrium between Cyt *c*₂ and [BChl]₂ is influenced therefore by both the redox potential difference and the electric potential

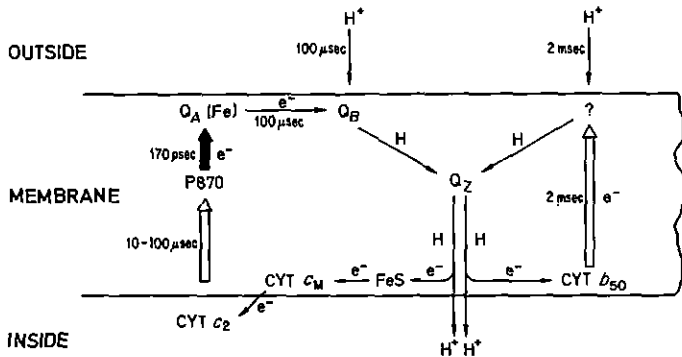

FIG. 8. Topology and kinetics of electrogenic reactions and protolytic reaction in chromatophores (for references, see text). Electrogenic reactions are indicated by wide arrows (filled arrows for the most rapid photochemical steps—open arrows for slower electron transfer steps). P870, reaction center BChl; Q_A ($\equiv Q_1$; primary quinone); Q_B ($\equiv Q_2$; secondary quinone); Q_Z (also a quinone); Cyt b_{50} = cytochrome b with an $E_{m} + 50$ mV.

difference between the two centers (Takamiya and Dutton, 1977). In conditions where Cyt c_2 is experimentally oxidized before the flash, the reaction $[BChl]_2 \rightarrow UQ_1$ still generates a delocalized potential across the chromatophore membrane (Packham *et al.*, 1980a). The positive charge created by the oxidation of $[BChl]_2$ can capacitatively couple with the internal aqueous phase of the chromatophore.

As in the chloroplast, the membrane potential generated in light-activated chromatophores is positive inside. A number of observations have led to this conclusion. First, the direction of the light-induced Car shift is the same as that produced by positive inside diffusion potentials and opposite to that produced by negative inside diffusion potentials (Jackson and Crofts, 1969). Second, the primary electron donor to the RC, Cyt c_2 , is located on the *inside* of the chromatophore membranes (Prince *et al.*, 1975), whereas the H^+ binding reaction that accompanies the reduction of UQ takes place on the *outside* of the membranes (Cogdell *et al.*, 1972; Petty and Dutton, 1976). The rapid H^+ binding reaction is probably the first step in light-induced H^+ uptake by the chromatophores. This process maintains the internal phase positive, as evidenced by K^+ efflux in the presence of valinomycin (Jackson *et al.*, 1968) or SCN^- uptake (Kell *et al.*, 1978a,b; Michels and Konings, 1978). Third, the light emission accompanying the photosynthetic back reaction from Q_1^- to $[BChl]_2^+$ is stimulated when the chromatophores are exposed to ionic diffusion potentials that are positive inside the vesicles (Fleischman, 1978). Borisov *et al.* (1980) have recently shown that the afterglow accompanying the back reaction from I^- (a transient inter-

mediate between $[BChl]_2$ and Q_1) is also enhanced by positive inside membrane potentials (generated by pyrophosphate hydrolysis). This suggests that the component reaction $[BChl]_2 \rightarrow I$ is also organized in the plane normal to the membrane.

Attempts to reconstitute purified RCs with artificial membranes (Bar-sky *et al.*, 1976; Drachev *et al.*, 1976; Crofts *et al.*, 1977; Packham *et al.*, 1980b) provide supportive evidence that the primary photosynthetic processes are directed anisotropically across the membrane. Particularly interesting is the finding of Packham *et al.* (1980b) that RCs incorporated into planar phospholipid bilayers will, under the appropriate conditions, generate bursts of electrical current when illuminated with single turnover flashes. Tris *et al.* (1982) recorded electric signals at <200 psec risetime from chromatophores and with RCs at hexane-water interface, which were interpreted to indicate that the primary charge separation is transmembrane with Bph located at one-third of the distance between P870 and Q_n .

There is also direct labeling evidence which suggests that the RC complex spans the membrane. The H subunit is accessible to membrane-impermeable reagents from the *outside* and possibly the inside of the chromatophores (Reed *et al.*, 1975; Valkirs *et al.*, 1976; Erokhin and Vasil'ev, 1978; Hall *et al.*, 1978) whereas the L and M subunits are predominantly labeled by lipophilic reagents (Zürer *et al.*, 1977; Odermatt *et al.*, 1980) and appear to reside close to the membrane core (also see Okamura *et al.*, Chapter 5, this volume).

Similar information is not available for components involved in the second electrogenic site. Indirect evidence suggests that Cyt b_{50} is the carrier on the inside of the membrane that accepts reducing equivalents from UQ and is responsible for an apparent pK on the release of protons on the inside of the chromatophore lumen (Petty and Dutton, 1976). It is a good candidate for the electrogenic carrier.

The nature of the electron transport pathway varies among different species of photosynthetic bacteria. The preceding observations may only apply to *Rp. sphaeroides* and *Rp. capsulata*, which have been studied in the most detail. In chromatophores from *Chr. vinosum*, for instance, the relative contributions of (the equivalent of) phases I and II to the first electrogenic reaction are rather different: It seems that by far the larger component arises from $Cyt\ c_{5,55} \rightarrow [BChl]_2$. By analogy, Cyt $c_{5,55}$ is expected to be found on the inside of the chromatophore membrane and the RC BChl toward the outside. In this case, the photochemical reaction $[BChl]_2 \rightarrow$ menaquinone only barely contributes to the formation of membrane potential (Case and Parson, 1973b). In chromatophores from

Rp. gelatinosa the situation appears to be somewhat intermediate between that found in *Rp. sphaeroides* and *Chr. vinosum* (Dutton, 1971).

2. THE MAGNITUDE OF THE ELECTRIC POTENTIAL DIFFERENCE IN CHROMATOPHORES

a. Excitation with Single Turnover Flashes. Two different calibration procedures for the electrochromic absorption changes yielded similar values for the magnitude of the membrane potential generated by short flashes. The use of potassium diffusion potentials (after Jackson and Crofts, 1969) gave 48 mV and calibration with alamethicin (after Zickler *et al.*, 1976) gave 58–86 mV for a single transmembrane passage of electrons through $\text{Cyt } c_2 \rightarrow [\text{BChl}]_2 \rightarrow \text{UQ}_I$ (see Packham *et al.*, 1978a, b). The former procedure is more reliable so that the value of the electric potential difference generated across chromatophore membranes during the transport of one electron through *both* electrogenic sites is approximately 100 mV.

Symons *et al.* (1979) recommend the use of correction factors for the diffusion potential calibration although the justification for this is not clear: First, the chromatophores used by Symons *et al.* (1979) were K^+ -permeable in the absence of valinomycin, probably due to prolonged storage under liquid nitrogen (J. B. Jackson and M. Symons, unpublished results). Freshly prepared chromatophores have an absolute requirement for valinomycin for induction of potassium permeability. Second, the correction for concomitant salt-induced surface potential changes is normally unnecessary since experiments are usually carried out against a background of 50–100 mM of either sodium or choline chloride (e.g., Jackson and Crofts, 1969; Baccarini-Melandri *et al.*, 1977; Matsuura and Nishimura, 1977; Packham *et al.*, 1978).

b. Excitation of Chromatophores with Continuous Light. Electrochromic measurements (Jackson and Crofts, 1969, 1971; Baccarini-Melandri *et al.*, 1977; Matsuura and Nishimura, 1977), oxacarbocyanine measurements (Pick and Avron, 1976), and ion distribution measurements (Isaev *et al.*, 1970; Michels and Konings, 1978; Ferguson *et al.*, 1979) all indicate a substantial membrane potential in chromatophores in continuous light in a variety of ionic media. Chromatophores are very much less permeable to ions such as K^+ , Na^+ , Cl^- than are thylakoids and it is unlikely that these ions reach the equilibrium defined by the Nernst–Planck equation, even after several minutes of illumination. A comparison of the kinetics of the electrochromic absorption change and

of H^+ uptake (Jackson and Crofts, 1971) illustrates this point: The electrochromic absorption change reaches a maximum (of about 350–400 mV) after about 1 sec of illumination. Thereafter it begins to drop slowly (to less than 250 mV after 3 min in the light). The kinetics of H^+ uptake by the chromatophores parallel the drop in the membrane potential (contrast the relatively rapid uptake of H^+ by thylakoids). The explanation is that slow uptake of Cl^- (or efflux of K^+) results in a slow and partial replacement of $\Delta\psi$ by ΔpH while a constant $\Delta \bar{\mu}_{H^+}$ is maintained. An increase in the potassium permeability may be effected by treatment with valinomycin. This leads to a decrease in the rate of $\Delta\psi$ development (measured by electrochromism) owing to a more rapid K^+ efflux during illumination—toward a Nernst–Planck distribution of K^+ . During this process, however, the generation of ΔpH is enhanced and this results in a lowered final value of $\Delta\psi$. A number of authors have studied the relative contributions of $\Delta\psi$ and ΔpH to $\Delta \bar{\mu}_{H^+}$ in continuous light in the presence of different classes of ionophore and permeant ions, either by direct measurements or by observations on the rates of ATP synthesis in the presence of these agents (Jackson *et al.*, 1968; Jackson and Crofts, 1971; Gromet-Elhanan and Leiser, 1973; Pick and Avron, 1976; Baccarini-Melandri *et al.*, 1977; Leiser and Gromet-Elhanan, 1977).

To date there has been no consensus on the absolute value of the chromatophore membrane potential generated during continuous illumination. Trivial differences in chromatophore preparation and storage, ionic composition of the media, and light intensity may account for some discrepancies between different laboratories. There may be more serious differences in methodology: Electrochromic measurements give values that are higher (200–250 mV) than those determined by ion distribution (60–150 mV). These discrepancies may be partly rationalized by the argument put forward in Section IV,A,3,b that the electrochromic absorption changes monitor changes in both bulk phase and surface potential, and that internal acidification in the light results in an increase of internal surface potential. However the *extent* of the internal acidification during continuous illumination is also subject to controversy: Measurements with the fluorescent probe, 9-aminoacridine, indicate a rather large change (ΔpH about 3), whereas determinations of amine distribution give $\Delta pH = 1$ (Michels and Konings, 1978) or $\Delta pH \approx 0$ (Kell *et al.*, 1978a).

In early experiments the importance of determining ΔpH and $\Delta\psi$ in chromatophores in continuous light was to establish the thermodynamic competence of $\Delta \bar{\mu}_{H^+}$ as the driving force for ATP synthesis. The em-

phasis has recently shifted towards the use of these parameters together with the phosphorylation potential (ΔG_p) to estimate the probable stoichiometry of proton translocation through the ATP synthetase (see Ort and Melandri, Chapter 12, this volume). These determinations call for reliability and high precision of the measuring technique.

C. Intrinsic and Artificially Induced Ionic Conductivity of Thylakoid and Chromatophore Membranes

Reasonable estimates for the intrinsic ionic conductivity of thylakoid and chromatophore membranes may be obtained from the decay of the electrochromic absorption changes after a flash of light. Typically the decay time in freshly prepared thylakoids is 100–300 msec, and in chromatophores (after elimination of a component due to the photosynthetic back reaction) it is of the order of 14 sec. Using an estimated specific capacitance of $0.5 \mu\text{F cm}^{-2}$ for thylakoids and a measured value of $1.1 \mu\text{F cm}^{-2}$ for chromatophores, the conductivities ($\kappa = C/\tau$) are then 2×10^{-5} mho cm^{-2} and 10^{-7} mho cm^{-2} , respectively. These conductivity values are at the low end of the scale for biological membranes. The conductivity of thylakoids and of chromatophores are dominated by different ions.

In thylakoids exposed to flashing light or moderate continuous light the ionic current is carried mainly by K^+ , Cl^- , and Mg^{2+} but not by protons. This is evident from the comparatively slow relaxation of a pH difference ($\tau = 5\text{--}10$ sec); see Junge and Ausländer (1974). In isolated chloroplasts the dominance of a given ion seems to depend on the chosen suspending medium (see Dilley and Vernon, 1965; Schröder *et al.*, 1972; Hind *et al.*, 1974) with only poor selectivity of the membrane (Barber, 1972). In intact chloroplasts, however, Mg^{2+} is the dominating ion which electrically counter-balances most of the pumped protons (Krause, 1973, 1974; Barber *et al.*, 1974; Portis and Heldt, 1976). Again, this may be attributed to the abundance of magnesium in the intact chloroplasts rather than to selective permeability. The specific Mg^{2+} content of intact chloroplasts is $2.33 \mu\text{M}/\text{mg Chl}$ as determined by Nakatani and Barber (cited in Barber, 1977).

Under strong continuous light, the internal phase becomes more acidic by as much as 4 pH units. There is evidence (Gräber and Witt, 1976) that the proton current (possibly via the coupling factor for photophosphorylation) then exceeds the electric current carried by other ions.

In contrast, the ionic current in chromatophores is carried by H^+

even after flash excitation; the decay of the electrochromic absorption change is precisely similar to the decay of the absorption change of externally added pH indicators (Saphon *et al.*, 1975b). The relatively low permeability of the chromatophores to K^+ , Mg^{2+} , Cl^- accounts for their low conductance compared with thylakoids and for the high membrane potential that they maintain during continuous illumination. The decay kinetics of the electrochromic absorption changes in intact cells of photosynthetic bacteria are not very different from those found in chromatophore preparations.

In both thylakoids and chromatophores the membrane conductance may, in appropriate conditions, be increased by providing ADP in the presence of phosphate (Junge *et al.*, 1970; Saphon *et al.*, 1975a,b; Petty and Jackson, 1979a, b). This is a consequence of increased proton flux through the H^+ -ATPase responsible for ATP synthesis. The increased conductance is non-ohmic so that ionic gating mechanisms may operate on this enzyme. (For details on the nature of the enzyme, see McCarty and Carmeli, Chapter 14, this volume.)

Agents that change the ionic conductivity of artificial bimolecular lipid membranes also act on the thylakoid and chromatophore membranes. Some of the observed peculiarities are perhaps worth mentioning. The pore-forming antibiotic gramicidin D accelerates the decay of the electric potential difference across thylakoid at relative concentrations, as low as one molecule per 10^5 Chl molecules (Junge and Witt, 1968). At relative concentrations of $1:10^6$, it starts to act as an uncoupler, increasing the proton permeability of the membrane, while at a proportion of 1:10 it starts to interrupt electron transport chains in the same way as detergents (Junge, 1968). Gramicidin fails to act as an ionic pore in chromatophores, perhaps, because of the small radius of curvature in these vesicles.

Valinomycin and nonactin act with similar turnover times in thylakoids and chromatophores as in model membranes. In chromatophores, valinomycin is effective at concentrations of one molecule per 10^4 BChls, i.e., one ionophore per vesicle (Saphon *et al.*, 1975a) and increases the membrane conductance almost linearly across 3 decades of concentration (see Packham *et al.*, 1980a, b). In thylakoids, however, only 1 molecule out of 100 reversibly bound to the membrane seems to be active in ion transport (Schmid and Junge, 1975), and at high concentrations valinomycin increases proton permeability and even begins to inhibit electron transport (Telfer and Barber, 1974). Alamethicin acts as a voltage-dependent, pore-forming agent in a manner similar to its action in model membranes, both in thylakoids (Zickler *et al.*, 1976) and

chromatophores (Packham *et al.*, 1978). Some uncoupling agents, like carbonyl cyanide-*m*-chlorophenylhydrazone, in addition to behaving as H⁺ carriers, interfere with the water-oxidizing system of thylakoids (Renger, 1972).

D. Localized versus Delocalized Electric Fields

The primary photochemical charge separation generates localized dipole fields between the electron-hole pairs. Only subsequently does ionic conduction in the adjacent aqueous phases distribute the electric field over the membrane capacitance. There is evidence that the electric field is delocalized over the entire area of the thylakoid or chromatophore in less than 10 msec: (1) ionophores at a concentration equivalent to one molecule per membrane vesicle accelerate the decay of the electrochromic absorption changes (Junge and Witt, 1968; Saphon *et al.*, 1975a); (2) Witt and Zickler (1973) by an electrode technique showed that fast ionic conduction delocalizes an electric imbalance around one thylakoid in approximately 10 μ sec, under typical salt conditions; and (3) in chromatophores one H⁺ per electron, transported through the photochemical RC, is abstracted from the external bulk aqueous phase within 200 μ sec (Petty and Dutton, 1976). Nevertheless, the concept of a rapidly delocalized electric field has often been challenged. Yamamoto and Nishimura (1977, 1978a,b) have reported the failure to observe a parallel kinetic behavior of the electrochromic absorption changes at 478 nm and at 520 nm. This could be interpreted to indicate that the electric generators associated with PSI and with PSII, respectively, charge different and electrically unconnected portions of the thylakoid membrane. The reported observations are, however, at variance from those of other authors (e.g., Emrich *et al.*, 1969) and the interpretation is in direct contradiction with the work cited earlier on the action of the gramicidin.

Local electrochromic effects have been observed under very special conditions. In isolated PSI particles, the interpretation of the complicated difference spectrum of P700 requires the assumption that one spectral component results from a small red shift of special antennae peaking around 680 nm (Schaffernicht and Junge, 1981). Also, at low temperature in whole thylakoids, electrochromic signals at 520 nm were observed only under excitation of PSII but not of PSI (Vermeglio and Mathis, 1974; Conjeaud *et al.*, 1976). This is in line with the idea that these absorption changes are caused by a lutein-Chl *b* complex, which belongs to PSII (see earlier). That this local electrochromism is due to

the freezing out of ionic currents is also obvious from the extremely long lifetime of the absorption changes under these conditions (10 min).

Local electrochromic absorption changes have been observed in (non-vesicular) RC preparations isolated from Car-containing strains of bacteria (Cogdell *et al.*, 1977). Absorption band shifts of the pigment were observed upon chemical oxidation of P870 or reduction of Q_1 . Calculations showed, however, that these absorption changes make an insignificant contribution to the electrochromic spectrum of chromatophores with their large excess of antenna Car.

V. Protolytic Reactions in Thylakoids and in Chromatophores

Since proton translocation and its consequences for ATP synthesis has been treated by other contributors in this volume, we shall concentrate here on the elementary acts of proton uptake from and proton release into the aqueous phases adjacent to the membrane. Also, we restrict ourselves to the one technique for measuring protons which has provided the required time resolution to identify these steps, i.e., flash spectrophotometry with pH-indicating dyes. We start with a description of those dyes and then proceed to the various protolytic reaction steps in thylakoids and in chromatophores.

This section is more condensed than the foregoing ones; it also contains fewer references (for further discussion, see Cramer and Crofts, Chapter 9; Ort and Melandri, Chapter 12; and McCarty and Carmeli, Chapter 14, this volume).

A. pH-Indicating Dyes

The simplest pH-indicating dyes are those which monitor the bulk phase external pH. Chlorophenol red (pH 5.2–6.8), phenol red (pH 6.5–8.7), cresol red (pH 7.1–8.7), and phenol violet (pH 8.2–9.8) provide a useful range. These dyes do not appear to bind significantly to chromatophore membranes (see Cogdell *et al.*, 1972; Petty and Dutton, 1976). They have been used extensively for measurements of rapid (10^{-6} – 10^{-3} sec) H^+ binding on the outside of thylakoids (Ausländer and Junge, 1974; Junge and Ausländer, 1974) and chromatophore membranes (Chance *et al.*, 1970; Cogdell *et al.*, 1972; Petty and Dutton, 1976; Petty *et al.*, 1979) following short light pulses (see later).

Rapid measurements of the pH of the internal space of the vesicles is more problematic. Limited success has been achieved by soaking chromatophores in the nonbinding dyes and then quickly removing the ex-

ternal dye by gel filtration. Signals due to internal acidification have then been observed following flash excitation although detailed work was confounded by leakage of the indicator (Petty and Dutton, 1976).

The behavior of one dye, neutral red, in thylakoid membranes is exceptional. It seems to behave as a true pH indicator for transients that occur in the internal phase of thylakoids once the pH transients outside the membrane are selectively buffered away by the non-permeant bovine serum albumin (Ausländer and Junge, 1975; Junge *et al.*, 1979). The reason for this is explained here.

A thylakoid suspension at reasonable optical density (i.e., at 10 μM Chl) has an inner to outer (aqueous) volume ratio of less than 1:1000. The specific buffering capacity of the internal groups is only three to four times less than that of the outer groups. This implies that operation of the proton pumps (induced by a flash of light) induces pH transients of the same order of magnitude in both aqueous compartments (in the absence of added buffers). However, those changes in the outer phase are "seen" by more than one-thousand times more molecules of a water soluble dye than those inside. It follows that water-soluble pH indicators

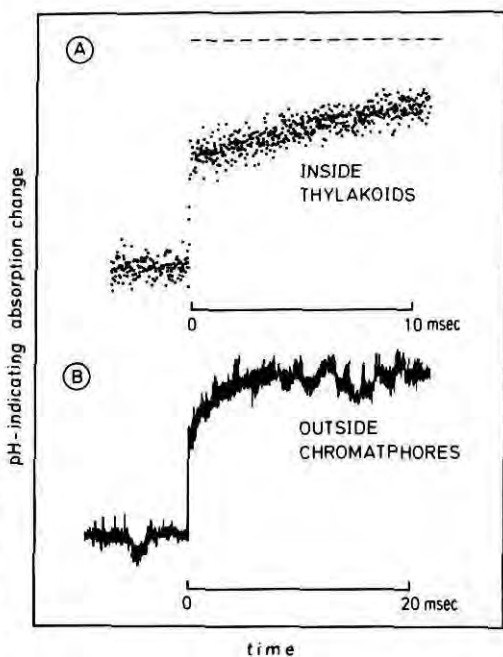

FIG. 9. Time course of pH-indicating absorption changes after flash excitation of thylakoids (A) and of chromatophores (B), respectively. (A) Recorded via the membrane adsorbed dye neutral red (13 μM) in a chloroplast suspension under selective buffering of the external phase by bovine serum albumin (1.3 mg/ml) (Ausländer and Junge, 1975; Junge *et al.*, 1979). The signal represents pH changes in the interior of thylakoids (compare Fig. 6). (B) Recorded via the water soluble indicator dye chlorophenol red (50 μM) in a chromatophore suspension (Petty *et al.*, 1977). The signal represents pH changes in the outer phase (compare with Fig. 8).

(true membranophobics) are practically selective for pH changes in the outer aqueous volume. The situation is very different with an amphiphilic dye like neutral red which is adsorbed to the membrane-water interface and therewith becomes effectively "enriched" in the internal phase. Under selective buffering of the external phase (bovine serum albumin), it becomes a pH indicator which is selective for transients inside. It has been shown that it records pH changes inside and only these, when properly used (for appropriate controls, see Junge *et al.*, 1979, and Gutman *et al.*, 1981, for model studies with this dye).

This provides one example for recording pH transients inside a sub-microscopic vesicle with unprecedented sensitivity and time resolution (Fig. 9). Application of neutral red for the resolution of large pH changes inside thylakoids under continuous illumination is more difficult (Pick and Avron, 1976). It invokes problems which are encountered with other distribution probes. It is also worth noting that this dye may behave quite differently in other membranes. When added to rod outer segments from bovine retinae, its pK is shifted so far towards alkalinity that, at physiological pH, it behaves as a distribution probe for the surface potential inside disks (Schnetkamp *et al.*, 1981).

B. Protolytic Reactions Involving Quinones

Common to both thylakoids and chromatophores is the involvement of quinones (plastoquinones in thylakoids and ubiquinones in the purple bacteria) in proton pumping. In thylakoids, another proton uptake site is provided by the terminal electron acceptor and another release site by the ultimate electron donor, water. The original proposal by Mitchell (1961, 1966) is that upon reduction of quinones to the hydroquinone stage $2H^+/2e^-$ are bound, hydroquinone acts as an electron-plus-proton-equalled-hydrogen carrier across the respective membrane to release $2H^+/2e^-$ upon reoxidation at the inner side of the membrane. This had to be modified to account for three intriguing features of proton pumping by quinones in both thylakoids and chromatophores: (1) the quinones involved in electron and proton transfer are nonhomogeneous. The special environment of "bound quinones" influences their interaction with protons (and also their ESR visibility) in comparison with those quinones in the respective "pool"; (2) there is a complicated interplay between quinones and *b*-type Cyts; (3) reduction of bound quinones may cause protolytic reactions of the host protein. These complications do not invalidate the hydrogen-carrying and, thus, proton-pumping action of quinones in photosynthesis. Also in neither system does there seem to

be a deviation of a $2\text{H}^+/2e^-$ stoichiometry with respect to electrons carried by the quinone and protons pumped at the quinone site. The detailed mechanism of hydrogen carriage across the membrane, however, still awaits elucidation.

1. PROTOLYTIC REACTIONS INVOLVING QUINONES IN THYLAKOIDS

Plastoquinone is the intermediate electron carrier between PSII and PSI. A pool of more than six plastoquinone molecules per pair of RCs serves as a kinetic buffer. Under excitation with single turnover flashes, members of the pool become reduced in 0.6 msec by PSII and reoxidized in about 20 msec by PSI (Stiehl and Witt, 1968, 1969). In addition to the plastoquinone associated with the pool, there seem to be two special quinones Q or X-320 (Stiehl and Witt, 1968) and R or B (Bouges-Bocquet, 1973; Velthuys and Amesz, 1974) accepting electrons prior to the pool and structurally immobilized so that the dismutation of the singly reduced (semiquinone) stage of this pair of special quinones is prevented. The known sequence of electron acceptors in PSII then is: P680 (Döring *et al.*, 1968), pheophytin *a* (Klimov *et al.*, 1980), Q and B (or R), the special quinones, and pool plastoquinone. (For further details, see Parson and Ke, Chapter 8, and Cramer and Crofts, Chapter 9, this volume.) Upon transfer of one electron into the oxidized Q-B-pair the state Q,B^- is rapidly formed and it remains stable for some seconds (Pulles *et al.*, 1976). Upon input of a second electron via the state Q^-, B^- the state Q,B^{2-} emerges which is the first to transfer electrons to the pool (Bouges-Bocquet, 1973; Velthuys and Amesz, 1974). By comparison of the equilibrium constants for electron transfer within the Q,B system with equilibrium constants for dismutation of duroquinone in water-ethanol solution, Diner (1977) proposed that protonation of plastoquinone should occur at the B^{2-} level and hence at a periodicity of two under a series of flashes starting from the oxidized state (see also Pulles *et al.*, 1976).

The expected periodicity of two in proton uptake by plastoquinone under excitation of dark adapted chloroplasts with a series of flashes was not observed. A binary oscillation covered only less than $\pm 10\%$ of the total amplitude in the reports by some authors (Fowler, 1977a) and no oscillation was seen by others (Hope and Morland, 1979; Förster *et al.*, 1981). The absence of oscillations in the proton uptake is only partially explained by the 7:3 ratio of the B/B^- dark equilibrium (Mathis and Havemann, 1977). This discrepancy is not well understood. It can only be speculated that formation of the semiquinone B^- may cause protona-

tion of its host protein. This would be similar to the situation in chromatophores, where a more pronounced period of two in proton uptake was observed which faded away at higher pH (Vermeglio, 1977; Wraight, 1977). This was interpreted to indicate proton binding by a protein upon quinone reduction (Wraight, 1978).

In this context another observation may be of importance, namely the existence of a diffusion barrier for protons which exists between the reduction sites of bound quinones and the outer aqueous phase in thylakoids (Ausländer and Junge, 1974). As illustrated in Fig. 6, proton uptake by plastoquinone from outside has a half-risetime of 60 msec (monitored via the dye bromocresol purple under excitation with short flashes, 10 sec repetition), while the release of the expected, same protons inside occurs at 20 msec. It was proposed that protonation of reduced quinone occurred first from intraprotein buffering groups which were refilled slowly with protons from the outer aqueous phase (Ausländer and Junge, 1974). The transfer of charge across the shield structure at 60 msec was not visible in the electrochromic absorption changes. (Hence the shield structure should possess a much higher dielectric constant than the membrane core.) It is probable that the discrepancy between uptake velocity and release velocity disappears at higher excitation rates. The diffusion barrier is probably proteinaceous. It could be lowered by mechanical disintegration of chloroplasts and furthermore by detergents and protonophores. At the extreme, proton uptake was accelerated to 2 msec (instead of 60 msec of the control) which was close to the time for hydroquinone formation. The residual delay time (2 msec) in proton uptake as compared to the reduction of the bound quinones was equal to a delay (of 2 msec) that was observed for the reduction of P700 and that could be attributed to a protolytic reaction by independent evidence (Haehnel, 1976). A diffusion barrier also became apparent from studies on the access of electron acceptors to the reducing site of PSII under controlled trypsin digestion of outer proteins (Renger, 1979).

The biological objective for the interplay of bound quinones and buffering groups of the "host" protein is unknown. The presence of bound quinone B, preceding the pool quinone in the electron transport chain, facilitates the transition from one-electron transfer (P680, bound quinone Q) to two-electron transfer (in the pool). A proton stored in the host protein as counterion to the semiquinone anion may also serve as protection of the system against escape of the radical semiquinone form.

The gross topology of the proton pumps and the kinetic parameters are illustrated in Fig. 6. (The protolytic features of the cyclic branch of the electron transfer involving quinone (see lower part of Fig. 6) experi-

mentally are not well documented. Therefore no discussion of this is attempted.)

2. PROLYTIC REACTIONS INVOLVING QUINONES IN CHROMATOPHORES

Two protons are bound to the outside of the chromatophore membrane for every electron proceeding through the cyclic electron transport chain (Petty *et al.*, 1977). The two proton binding reactions may be distinguished by different antimycin sensitivity, kinetics, redox potential dependence, and associated pK values (Petty and Dutton, 1976; Petty *et al.*, 1979). It is likely that UQ is involved in both H⁺ binding reactions but only in outline are the experimental data consistent with the view that a proton binding reaction follows each of the two electrogenic electron transport reactions (see Section IV,B) and allows subsequent electroneutral (e.g., UQH₂) oxidation–reduction and proton transport across the membrane (i.e., by an orthodox chemiosmotic mechanism). Detailed analysis shows that the system is more complex and that other interactions must be involved (for discussion, see Petty *et al.*, 1979; Wraight, 1979a).

The first ubiquinone (UQ_I≡Q_A) to be reduced during photosynthesis ($t_{1/2} \approx 200$ psec, Kaufmann *et al.*, 1975; Rockley *et al.*, 1975) is not protonated on a functional time scale (Dutton *et al.*, 1973). Electron transport from UQ_I⁺ to a “secondary” acceptor, Y [now known to be another ubiquinone (UQ_{II}≡Q_B)] within hundreds of microseconds is accompanied (perhaps after a slight delay) by H⁺ binding (Halsey and Parson, 1974; Petty and Dutton, 1976; Takamiya and Dutton, 1979). This protolytic reaction (H_I⁺) is insensitive to antimycin A. The H_I⁺ binding is suppressed at alkaline pH with an apparent pK at 8.5 (Petty and Dutton, 1976), although the E_m /pH relationship has a break at pH 8.0 (Petty *et al.*, 1979). Unfortunately, neither of these values coincide with pK of 9.8 reported for the semiquinone (Rutherford and Evans, 1980). H_I⁺ binding is probably related to the H⁺ binding reaction observed in photosynthetic RC preparations where UQ_{II} (or Q_B) has been clearly identified as the H⁺ binding agent (Wraight, 1979b). Comparison between the chromatophores and the purified protein complex is, however, not simple, since the latter (at least at low pH) only binds H⁺ after an even number of flashes (Vermeglio, 1977; Wraight, 1977), whereas periodicity is observed as an exception in chromatophores (Barouch and Clayton, 1977). Even in RCs the H⁺ binding processes at this site are complex and appear to involve ancillary acid–base groups (Wraight, 1979b) as in thylakoids.

The antimycin sensitivity of the second H⁺ binding reaction (H_{II}⁺) in

chromatophores argues for its intimacy with the second electrogenic reaction—in the Cyt *b-c*₂ complex. Early work predicted that *z*, a redox carrier intermediary between Cyt *b* and Cyt *c*₂, and now known to be another population of UQ (UQ_{*z*}, Takamiya and Dutton, 1979), might be the agent responsible for H₁₁⁺ binding. The antimycin sensitivity and the kinetics at low redox potential (Petty *et al.*, 1977) support this contention but other factors mitigate against it: (1) H₁₁⁺ has a *pK* at 7.5 whereas UQ_{*z*} maintains a constant 60 mV *E*_m/*pH* relation from *pH* 6–11 (Prince and Dutton, 1977) [a *pK* of 7.5 is demonstrated by Cyt *b*₅₀]; (2) the rate of H₁₁⁺ binding at high redox potential is faster than Cyt *b*₅₀ reduction; and (3) extraction of UQ_{*z*} (and UQ₁₁) from the chromatophores leaves antimycin-sensitive H⁺ binding intact.

Despite the fact that intensive experimentation in this area has led to a better understanding of the nature of H⁺ interaction with the chromatophore electron transport chain, no overall picture has yet emerged. To some extent the investigations have been hampered by difficulties in interpreting data on the pathway of electron transfer through the UQ/Cyt *b-c*₂ oxidoreductase—for instance, whether “loops” or “Q cycles” are involved. So far the temptation to invoke split pathways of electron transport or conformationally coupled H⁺ pumps has been resisted. (However, see Cramer and Crofts, Chapter 9, this volume.)

C. Proton Release inside Thylakoids during Water Oxidation

To produce one molecule of oxygen from two molecules of water requires four oxidizing equivalents. If these were electron holes, then four protons should be liberated with oxygen. In the original proposal by Kok *et al.* (1970) the manganese-containing enzyme complex which splits water was visualized as a charge accumulating device (electron hole accumulator) (for reviews, see Joliot and Kok, 1975; Radmer and Chéniaie, 1977; Wydrzynski, Chapter 10, this volume). Early experiments by Fowler and Kok (1974a) on *pH* changes accompanying O₂ evolution under excitation of dark-adapted chloroplasts by a group of short flashes seemed to confirm the concept that proton release like O₂ liberation occurred in a burst after the third flash in a row. Later experiments, however, did not support this idea. It was observed that proton release does not follow the pronounced oscillatory pattern of oxygen liberation with its period of four and with the maxima at flash numbers 3, 7 etc. Instead, all authors agree on very little oscillation of proton release (Fowler, 1977b; Junge *et al.*, 1977; Saphon and Crofts, 1977a; Hope and Morland, 1979; Velthuys, 1980; Bowes and Crofts, 1981; Förster *et al.*,

1981). These authors concluded that protons are liberated during at least three of the transitions between the successive oxidation states (S_0 , S_1 , S_2 , S_3 , . . .). This could indicate that (complexed) water is oxidized stepwise by the enzyme complex (with the hazardous intermediates like OH bound to manganese) as postulated by Renger (1977). An alternative is the accumulation of electron hole on manganese which is stabilized by OH^- serving as the specific counter ion, before being oxidized in a terminal step (see Govindjee *et al.*, 1977; Sauer, 1980).

There is a controversy over the proton to electron stoichiometric pattern under excitation of thylakoids with a series of short flashes that are given to a dark-adapted sample. The major discrepancy concerns the number of protons originating from the water-oxidizing system after the first flash of light. This was comparably low in the experiments of Fowler (1977b), Saphon and Crofts (1977a), and Velthuys (1980), and it was high for Jünge *et al.* (1977) and Hope and Morland (1979). Correlating the pattern of proton release with the transitions between the oxidation states S_0-S_1 , S_1-S_2 , S_2-S_3 , S_3-S_4/S_0 , the former authors concluded that the pattern of protons over electrons during these transitions is 1:0:1:2 while the latter authors favored 0:1:1:2 and 1:1:1:1, respectively. This was particularly disturbing as the four latter groups used the same experimental approach for the detection of protons, the neutral red technique, as introduced by Ausländer and Junge (1975). Recently, it was reported that the different patterns of proton release depend on different modes of dark-adaptation (Förster *et al.*, 1981). When chloroplasts that were stored under liquid nitrogen were used in a way that they had seen no light at all between thawing and the beginning of the spectrophotometric experiments, very little proton release occurred after the first flash of light. Higher proton release was observed, however, if they had seen light even if they had 10–30 min of dark-adaptation prior to the photometric experiment. Such a relatively long period is considered as sufficient for the relaxation of the water-oxidizing system with respect to O_2 evolution. The situation is further complicated by the following: Proton release into thylakoids can be time resolved. Those protons which are believed to originate from the water-oxidizing enzyme system appear with a multiphasic kinetic pattern with half-risetimes ranging from 100 μsec to 1 msec (Förster *et al.*, 1981). Those phases rising with halftimes of 250 μsec , 500 μsec and 1000 μsec could be attributed to the transitions S_0-S_1 , S_2-S_3 , and S_3-S_4/S_0 , which agree well with the supposed oxidation kinetics of the water-splitting enzyme system, as evident for instance from measurements on the ESR signal 11vf (Babcock *et al.*, 1976). One component, that is particularly strong after the second flash, and which is very rapid (100 μsec) had to be

attributed to a protolytic reaction that precedes the water-oxidizing enzyme system (Förster *et al.*, 1981). This was supported by the observation of a push and pull of protons at the inner side of the thylakoid membrane during a cyclic operation of PSII under conditions when no water oxidation occurs (DCMU-poisoning of the secondary quinone acceptor site) (Hong *et al.*, 1981). It seems as if there are further protolytic reactions associated with the operation of PSII in addition to those attributed to the action of the water-oxidizing enzyme system. Whether some or all of these reactions are obligatory for the proper functioning of the electron transfer chain from water to PSII remains to be established.

It is generally agreed that protons which result from water oxidation are released into the internal space of thylakoids. However, there is some controversy as to whether they are dumped into the internal osmolar water space or into some channels or layers within or adjacent to the thylakoid membrane. Besides theoretical arguments (see Kell, 1979), there are experiments from one research group which seem to indicate that protons which are released by PSII activity prevent while those from PSI do not prevent the binding of certain modifiers to thylakoid membranes. This has been interpreted as an indication of heterogeneity of the proton-receiving domains inside thylakoids (Prochaska and Dilley, 1978; Baker *et al.*, 1981). On the other hand it has been shown that the pH changes inside thylakoids, as monitored via the absorption changes of neutral red, were to be buffered away by several chemically very different buffers, among these being notorious hydrophilics like phosphate, in a way that quantitatively reflected their buffering capacity in water and the magnitude of the internal osmolar volume (Junge *et al.*, 1979). This holds even for the most rapidly released water protons (Junge *et al.*, 1978). From this approach there is no doubt that protons which are liberated inside thylakoids enter the aqueous bulk phase much more rapidly than they are consumed by the ATP synthase. The experiments on which the later statement is based, were carried out mainly on freeze-thawed chloroplasts. Kinetic measurements on proton release in freshly prepared chloroplasts give some indication for a special affinity of protons from water oxidation to the proton wells which are opened upon mild extraction of the ATP-synthase (Theg and Junge, unpublished; Qian, Hong, and Junge, unpublished).

VI. Concluding Remarks and Working Hypotheses

A. Thylakoids

The thylakoid membrane is electrically charged by three outwardly directed electron transfer reactions. During transport of a single elec-

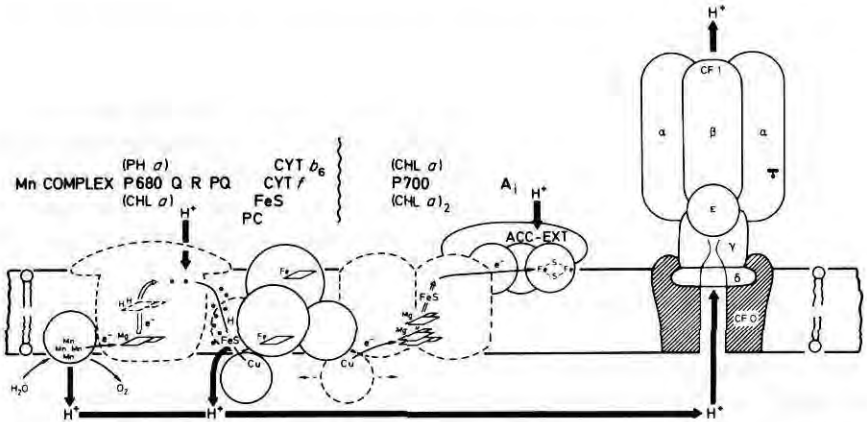

FIG. 10. Working hypothesis for chloroplasts. Artists' view of the carriers and enzymes involved in electron transport electric potential generation and in the pumping and usage of protons in thylakoids. The proteins are scaled according to their molecular weight (assuming a density of 1.4 g cm^{-3}). Chlorophylls (Mg), pheophytins (HH), and hemes (Fe) are given as squares. The location of the components within the membrane is inferred from studies on the electrogenic reactions. Mn-containing circle represents Mn-enzyme involved in O_2 evolution; Fe-S represent iron-sulfur centers; Cu represents plastocyanin; CF₁, chloroplast coupling factor; α - ϵ are subunits of CF₁; CF₀, hydrophobic (membrane) portion of ATPase; other symbols as in Fig. 6.

tron, each site contributes about 25 mV to the voltage across the membrane. Two of these reactions are linked to the primary photochemical acts, and the third one to a thermally activated cyclic electron transfer between the two photosystems. In Fig. 10, the structural information on the functioning of the photochemical electrogenic reactions in the linear electron transport chain plus the protolytic reactions which promote proton pumping is summarized. In this figure the components are tentatively scaled relative to an assumed membrane thickness of 5 nm: The ultimate source of electrons is water. Water is oxidized by an (as yet unisolated) Mn-containing enzyme complex which receives oxidizing equivalents from PSII (P680). Electron abstraction from this enzyme complex results in O_2 evolution and in the rapid injection of protons into the internal phase of thylakoids. There is good evidence that these protons rapidly equilibrate with the internal aqueous phase. The detailed fate of the protons liberated during the stepwise oxidation cycle of the water-splitting enzyme complex still awaits elucidation. The proton liberation has no kinetic analog in the voltage generation. Hence, the source of protons must be located very close to the internal border of the low dielectric region of the membrane.

Electrons from water refill a hole residing on a special Chl *a* named P680. After being hit by a quantum of light, P680 had transferred previously one electron across the full low dielectric core of the membrane. It is generally assumed that pheophytin (Ph *a*) is one of the intermediate electron carriers before the electron is accepted by a special bound plastoquinone (Q). The relative arrangement of Chl *a* (P680), Ph *a*, and Q and the mode of their interaction is not known. The biochemical properties of the "host" proteins of the photochemical center II are poorly characterized. With the aid of a second bound quinone (R or B) the one-electron transfer is converted to a two-electron transfer. It is likely that at this stage protonation of reduced quinone occurs, however, not in direct contact with the external bulk water. Instead, the (host) protein of R (\equiv B) seems to serve as an intermediate proton donor. The details of quinone reduction and protonation deserve further work.

Electrons and protons carried by plastoquinone "pool" somehow are transferred inwardly across the thylakoid membrane. The hydrogen transfer mechanism (the quinones acting as carriers or as a chain of relays) is not yet known. The electrons are donated to plastocyanin (Cu; PC) or to Cyt *f* (heme-Fe) with an iron-sulfur center (Fe-S) involved. Under conditions of cyclic electron transfer, the pair of electrons on plastoquinone splits to follow different pathways: one is transferred to P700, as in linear electron transport, the other one enters a loop which (via Cyt *b*₆) leads it back to the quinones at the outer side of the membrane. This is the third electrogenic step. This loop is not included in Fig. 10 (but see Fig. 6). Under conditions of purely linear electron flow, all electrons finally reduce the special Chl *a* in PSI (P700). The electron transfer from plastoquinone via plastocyanin to P700 does not electrically charge the thylakoid membrane. As plastocyanin is only loosely attached to the membrane (it probably serves to transfer electrons by diffusion from PSII centers in the partition section of thylakoids to PSI centers located more at the fringes), it is likely that the donor Chls also in PSI are located very near the internal border of the membrane dielectric. One proton per electron is released in the electron transfer between plastoquinone and P700 (under linear transfer). The release site (which is possibly also the major site for control of the electron transport rate by the internal pH), however, is not sufficiently characterized.

When hit by a quantum of light, P700 transfers one electron via another Chl *a*, special Fe-S centers, and ferredoxin to the terminal electron acceptor. Depending on the chemical nature of the acceptor(s), another proton is taken up at this site. Although the PSI complex is biochemically and physically better defined than PSII, the relative arrangement of P700 and of the intermediate electron carriers is still ob-

sure. One can only say that the sequence of reactions which occur at less than 200 psec bridges the full span of the low dielectric in the thylakoid membrane.

The electric potential difference, which is very rapidly generated under excitation of both photosystems by a short flash of light, is rapidly delocalized over the plane of the membrane. When it reaches the coupling factor for photophosphorylation (CF_1) via the channel protein (CF_0), it can drive protons through in a process which leads to the formation of ATP from ADP and phosphate.

B. Chromatophores

The chromatophore membrane is electrically charged by two outwardly directed electron transport reactions, each of which contribute about 50 mV to the voltage across the membrane. Figure 11 partly summarizes and partly speculates on the pathways of electron and proton transport in chromatophores. In general, the reactions within and adjacent to the photosynthetic RC are better characterized than those involving the Cyt *b* complex.

Within a few psec of the RC BChl special pair (originally designated P or P870) receiving a photon, it loses an electron to bacteriopheophytin (BPh). Even this very fast reaction contributes to the generation of mem-

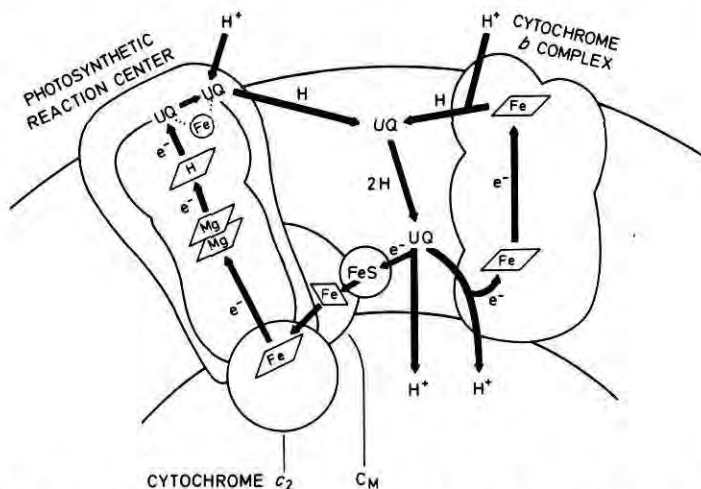

FIG. 11. Working hypothesis for chromatophores. Artists' view of the carriers involved in electron transport, electric potential generation, and proton pumping in chromatophores. The location of the carriers within the membrane is inferred from studies on the electrogenic reactions and on ESR work (for details see text). For definition of squares, see the legend of Fig. 10; UQ stands for ubiquinone.

brane potential so the reaction must have some component normal to the membrane. The reduced BPh passes on the electron to a specialized molecule of ubiquinone (UQ) to generate a semiquinone which is not protonated, although it is assumed to be located close to the outer membrane interface. The first electrogenic electron transport step is completed when P, at the center of the membrane dielectric, is re-reduced by Cyt c_2 , at the internal interface of the membrane. The oxidized Cyt c_2 awaits re-reduction through the cycle.

Meanwhile the electron in the primary UQ ($UQ_I=Q_A$) is transferred to a secondary UQ ($UQ_{II}\equiv Q_B$). There are many aspects of this reaction which remain unclear. An atom of iron is involved in some unknown way in the oxidation-reduction reaction between UQ_I and UQ_{II} . In isolated RCs at low pH, UQ_{II} does not bind H^+ until a second electron is delivered from the RC. However, in all but exceptional circumstances in chromatophores, one H^+ is bound per electron per flash. The difference between the H^+ binding in RCs and in chromatophores is not understood. The "host" protein may be involved in mediating H^+ transfer from solution to UQ_{II} .

The electron on UQ_{II} leaves the RC for the Cyt *b* complex. In contrast to the RC complex, this protein has only been isolated in crude form and is poorly characterized. Within the Cyt *b* complex an electron makes a second crossing of the membrane dielectric and further charges the membrane. The electrogenic carrier in this step has not been identified. One of the *b*-type Cyts may be involved although multiple forms of Cyt *b* complicate spectral analysis.

A second H^+ is bound on the outside of the chromatophore membrane during electron transfer through the Cyt *b* complex. Another species of UQ, UQ_z , may be responsible for returning electrons, as neutral H equivalents, back across the membrane. The expected release of two H^+ per electron to the inside aqueous phase of the chromatophore has only been indirectly demonstrated. Whether a "Q cycle" or a "loop" is operative is not known. Even a proton pump cannot be ruled out. A version of the Q cycle is shown in Fig. 11. The electron leaves the Cyt *b* complex by way of a "high potential" iron protein and a membrane bound form of Cyt *c* on its return to oxidized Cyt c_2 for the completion of the cycle.

The resulting electrochemical proton gradient provides the energy to drive H^+ back through the chromatophore F_0F_1 with concomitant ATP synthesis. The mechanism of this process is far from being understood.

C. Comparative Aspects

In both thylakoids and chromatophores the purpose of the generation of an electrochemical potential difference of the proton is the syn-

thesis of ATP. In bacteria this gradient is also involved in substrate transport. In chloroplasts reducing equivalents (NADPH) are also produced at the expense of water. The thylakoid electron transport is flexible in the proportion of ATP over NADPH formed, by virtue of a cyclic electron transfer segment. Some molecular components which participate in the cyclic electron transport segment in thylakoids are very similar to those of the obligatory cyclic system of bacteria, namely the hydrogen-carrying quinones, Cyt *b* complex, one special Fe-S center and the Cyts *c* and *f*, respectively. Also, there is correspondence between the acceptor regions of PSII and the bacterial RC, namely the bound and shielded quinones with their $1e^- - 2e^-$ transforming action and their peculiar protonation behavior.

However, we are not yet in a position to define the functional necessities or the evolutionary steps which produce similarities and differences. In particular it is not yet understood why the photochemical charge separation may span the full thickness of the membrane dielectric in thylakoids while only by one-half or less in bacteria.

Under continuous operation of their electron transport chains, there is one important difference between thylakoids and bacterial chromatophores; while the major portion of the electrochemical potential difference is in the chemical part in thylakoids ($\Delta \text{pH} \leq 4$), it is in the electrical part in chromatophores ($\Delta\psi \leq 200 \text{ mV}$). The necessity for this difference is possibly as follows: The chloroplast is a three compartment system. The inner compartment of thylakoids is very low in enzymatic activity. Therefore, a large variance of the pH of this very compartment (e.g., by three units) is not too "harmful." The chromatophore membrane, on the other hand, is an extension of the bacterial cell membrane. It separates the external phase from the one internal phase which carries all the enzymatic activity of this cell. The internal pH of the cell must therefore be maintained within fairly narrow limits.

REFERENCES

- Åkerlund, H. E., Anderson, B. L., Person, B., and Albertson, P. A. (1979). *Biochim. Biophys. Acta* **552**, 238-246.
- Amesz, J., and de Grooth, B. G. (1975). *Biochim. Biophys. Acta* **376**, 298-307.
- Amesz, J., and de Grooth, B. G. (1976). *Biochim. Biophys. Acta* **440**, 301-313.
- Arnon, D. I., Tsujimoto, H. Y., and McSwain, B. (1967). *Nature (London)* **214**, 562-566.
- Arntzen, C. J., and Briantais, J.-M. (1975). In "Bioenergetics of Photosynthesis" (Govindjee, ed.), pp. 51-113. Academic Press, New York.
- Ausländer, W., and Junge, W. (1974). *Biochim. Biophys. Acta* **357**, 285-298.
- Ausländer, W., and Junge, W. (1975). *FEBS Lett.* **59**, 310-315.
- Azzi, A., Gherardini, P., and Santano, M. (1971). *J. Biol. Chem.* **246**, 2035-2042.
- Babcock, G. T., Blankenship, R. E., and Sauer, K. (1976). *FEBS Lett.* **61**, 286-289.

- Baccarini-Melandri, A., and Melandri, B. A. (1977). *FEBS Lett.* **80**, 459-460.
- Baccarini-Melandri, A., Casadio, R., and Melandri, B. A. (1977). *Eur. J. Biochem.* **78**, 389-402.
- Baker, G. M., Bhatnagar, D., and Dille, R. A. (1981). *Biochemistry* **20**, 2307-2315.
- Baltscheffsky, M. (1967). *Biochem. Biophys. Res. Commun.* **28**, 270-276.
- Baltscheffsky, M., and Hall, D. O. (1974). *FEBS Lett.* **39**, 345-348.
- Barber, J. (1972). *FEBS Lett.* **20**, 251-254.
- Barber, J. (1977). In *Proc. Colloq. Int. Potash Inst.* **13**, 83-93.
- Barber, J. (1980). *Biochim. Biophys. Acta* **594**, 253-308.
- Barber, J., and Kraan, G. P. B. (1970). *Biochim. Biophys. Acta* **197**, 49-59.
- Barber, J., Telfer, A., and Nicolson, J. (1974). *Biochim. Biophys. Acta* **357**, 161-165.
- Barouch, Y., and Clayton, R. K. (1977). *Biochim. Biophys. Acta* **462**, 785-788.
- Barsky, E. L., Darcshazy, Z., Drachev, L. A., Il'ina, M. D., Kondrashin, A. A., Samuilov, B. D., and Skulachev, V. P. (1976). *J. Biol. Chem.* **251**, 7066-7071.
- Bashford, C. L., Chance, B., and Prince, R. C. (1979a). *Biochim. Biophys. Acta* **545**, 46-57.
- Bashford, C. L., Chance, B., Smith, J. C., and Yoshida, T. (1979b). *Biophys. J.* **25**, 63-85.
- Bashford, C. L., Prince, R. C., Takamiya, K., and Dutton, P. L. (1979c). *Biochim. Biophys. Acta* **545**, 223-235.
- Becker, J. F., Geacintov, N. E., and Swenberg, C. E. (1978). *Biochim. Biophys. Acta* **503**, 545-554.
- Bengis, C., and Nelson, N. (1975). *J. Biol. Chem.* **250**, 2783-2788.
- Berzborn, R. J., Kopp, F., and Mühlethaler, K. (1974). *Z. Naturforsch. C: Biosci.* **29C**, 694-699.
- Borisov, A. Yu., Godik, V. I., Kotova, E. A., and Samuilov, V. D. (1980). *FEBS Lett.* **119**, 121-124.
- Bouges-Bocquet, B. (1973). *Biochim. Biophys. Acta* **314**, 250-256.
- Bouges-Bocquet, B. (1980). *FEBS Lett.* **117**, 54-58.
- Bowes, J. M., and Crofts, A. R. (1981). *Biochim. Biophys. Acta* **637**, 464-472.
- Bowyer, J. R., Baccarini-Melandri, A., Melandri, B. A., and Crofts, A. R. (1978). *Z. Naturforsch., C: Biosci.* **33C**, 704-711.
- Boyer, P. D., Chance, B., Ernster, L., Mitchell, P., Racker, E., and Slater, E. C. (1977). *Annu. Rev. Biochem.* **49**, 955-1026.
- Breton, J. (1976). *Biochim. Biophys. Acta* **459**, 66-75.
- Bulychev, A. A., and Vredenberg, W. J. (1976). *Biochim. Biophys. Acta* **423**, 548-556.
- Bulychev, A. A., Andrianov, V. K., Kurella, G. A., and Litvin, F. F. (1976). *Nature (London)* **236**, 175-176.
- Casadio, R., Baccarini-Melandri, A., and Melandri, B. A. (1974). *Eur. J. Biochem.* **47**, 121-128.
- Case, G. D., and Parson, W. W. (1973a). *Biochim. Biophys. Acta* **292**, 677-684.
- Case, G. D., and Parson, W. W. (1973b). *Biochim. Biophys. Acta* **325**, 441-453.
- Chance, B., and Smith, L. (1955). *Nature (London)* **175**, 803-806.
- Chance, B., Crofts, A. R., Nishimura, M., and Price, B. (1970). *Eur. J. Biochem.* **13**, 364-374.
- Cogdell, R. J., Jackson, J. B., and Crofts, A. R. (1972). *Bioenergetics* **4**, 211-227.
- Cogdell, R. J., Monger, T. G., and Parson, W. W. (1975). *Biochim. Biophys. Acta* **408**, 189-199.
- Cogdell, R. J., Celis, S., Celis, H., and Crofts, A. R. (1977). *FEBS Lett.* **80**, 190-194.
- Conjeaud, H., and Michel-Villaz, G. M. (1976). *J. Theor. Biol.* **62**, 1-16.
- Conjeaud, H., Michel-Villaz, G. M., Vermeglio, A., and Mathis, P. (1976). *FEBS Lett.* **71**, 138-144.

- Crofts, A. R., Crowther, D., Celis, H., Celis, A. S., and Tierney, G. (1977). *Biochem. Soc. Trans.* **5**, 491-495.
- Crowther, D., Mills, J. D., and Hind, G. (1979). *FEBS Lett.* **98**, 386-390.
- Deamer, D. W., and Packer, L. (1969). *Biochim. Biophys. Acta* **172**, 539-545.
- de Grooth, B. G., and Amesz, J. (1977a). *Biochim. Biophys. Acta* **462**, 237-246.
- de Grooth, B. G., and Amesz, J. (1977b). *Biochim. Biophys. Acta* **462**, 274-258.
- de Grooth, B. G., van Gorkom, H. J., and Meiburg, R. F. (1980). *Biochim. Biophys. Acta* **589**, 299-314.
- Delosme, R., Zickler, A., and Joliot, P. (1978). *Biochim. Biophys. Acta* **504**, 165-174.
- Dijkema, C., Michels, P. A. M., and Konings, W. N. (1980). *Arch. Biochem. Biophys.* **201**, 403-410.
- Dilley, R. A., and Vernon, L. P. (1965). *Arch. Biochem. Biophys.* **111**, 365-375.
- Diner, B. A. (1977). *Biochim. Biophys. Acta* **460**, 247-258.
- Döring, G., Bailey, J. L., Kreutz, W., Weikard, J., and Witt, H. T. (1968). *Naturwissenschaften* **55**, 219-220.
- Drachev, L. A., Frolov, V. N., Kaulen, A. D., Kondrashin, A. A., Samuilov, V. D., Semenov, A. Yu., and Skulachev, V. P. (1976). *Biochim. Biophys. Acta* **440**, 637-660.
- Dutton, P. L. (1971). *Biochim. Biophys. Acta* **226**, 63-80.
- Dutton, P. L., Leigh, J. S., and Wraight, C. A. (1973). *FEBS Lett.* **36**, 169-173.
- Dutton, P. L., Petty, K. M., Bonner, H. S., and Morse, S. D. (1975). *Biochim. Biophys. Acta* **387**, 535-556.
- Emrich, H. M., Junge, W., and Witt, H. T. (1969). *Z. Naturforsch., B: Anorg. Chem., Org. Chem., Biochem., Biophys., Biol.* **24B**, 1144-1146.
- Erokhin, Y. E., and Vasil'ev, B. G. (1978). *Mol. Biol.* **12**, 574-579.
- Feldberg, S. W., and Delgado, A. B. (1978). *Biophys. J.* **21**, 71-86.
- Ferguson, S. J., Jones, D. T. G., Kell, D. B., and Sorgato, M. C. (1979). *Biochem. J.* **180**, 75-85.
- Fleischman, D. E. (1978). In "The Photosynthetic Bacteria" (R. K. Clayton and W. R. Sistrom, eds.), pp. 513-524. Plenum, New York.
- Förster, V., Hong, Y. Q., and Junge, W. (1981). *Biochim. Biophys. Acta* **638**, 141-152.
- Fowler, C. (1977a). *Biochim. Biophys. Acta* **459**, 351-363.
- Fowler, C. (1977b). *Biochim. Biophys. Acta* **462**, 414-421.
- Fowler, C. F., and Kok, B. (1974a). *Biochim. Biophys. Acta* **357**, 299-307.
- Fowler, C. F., and Kok, B. (1974b). *Abstr., Prog. Photobiol., Proc. Int. Congr., 6th, 1972 NR* 417.
- Gaensslen, R. E., and McCarty, R. (1971). *Arch. Biochem. Biophys.* **147**, 55-65.
- Gaensslen, R. E., and McCarty, R. (1972). *Anal. Biochem.* **48**, 504-514.
- Girault, G., and Galmiche, J. M. (1980). *Abstr., Eur. Bioenerg. Conf., 1st, 1980*, pp. 229-230.
- Govindjee, ed. (1982). "Photosynthesis: Development, Carbon Metabolism, and Plant Productivity," Vol. II. Academic Press, New York.
- Govindjee, and Jursinic, P. (1979). *Photochem. Photobiol. Rev.* **4**, 125-205.
- Govindjee, Wydrzynski, T., and Marks, S. B. (1977). In "Bioenergetics of Membranes" (L. Packer, G. Papageorgiou, and A. Trebst, eds.), pp. 305-316. Elsevier, Amsterdam.
- Gräber, P., and Witt, H. T. (1974). *Biochim. Biophys. Acta* **333**, 389-392.
- Gräber, P., and Witt, H. T. (1976). *Biochim. Biophys. Acta* **423**, 141-163.
- Gromet-Elhanan, Z. (1972). *Eur. J. Biochem.* **25**, 84-88.
- Gromet-Elhanan, Z., and Leiser, M. (1973). *Arch. Biochem. Biophys.* **159**, 583-589.
- Gross, E. L., and Libbey, J. W. (1972). *Arch. Biochem. Biophys.* **153**, 457-467.
- Gutman, M., Huppert, D., Pines, E., and Nachliel, E. (1981). *Biochim. Biophys. Acta* **642**, 15-26.

- Haehnel, W. (1976). *Biochim. Biophys. Acta* **440**, 506–521.
- Haehnel, W. (1977). *Biochim. Biophys. Acta* **459**, 418–441.
- Haehnel, W., and Witt, H. T. (1972). *Proc. Int. Congr. Photosynth.*, 2nd, 1971 pp. 469–476.
- Haehnel, W., Hesse, V., and Pröpper, A. (1980). *FEBS Lett.* **111**, 79–82.
- Hall, R. L., Doorley, P. F., and Niedermann, R. A. (1978). *Photochem. Photobiol.* **28**, 273–276.
- Halsey, Y. D., and Parson, W. W. (1974). *Biochim. Biophys. Acta* **347**, 404–416.
- Haraux, F., and de Kouchkovsky, Y. (1979). *Biochim. Biophys. Acta* **546**, 455–471.
- Hauska, G., and Trebst, A. (1977). *Curr. Top. Bioenerg.* **6**, 151–220.
- Heldt, H. W., Werdan, K., Milovancev, M., and Geller, G. (1973). *Biochim. Biophys. Acta* **314**, 224–241.
- Hind, G., Nakatani, H. Y., and Izawa, D. (1974). *Proc. Natl. Acad. Sci. U.S.A.* **71**, 1484–1488.
- Holmes, N. G., and Crofts, A. R. (1977a). *Biochim. Biophys. Acta* **459**, 492–505.
- Holmes, N. G., and Crofts, A. R. (1977b). *Biochim. Biophys. Acta* **461**, 141–150.
- Holmes, N. G., Hunter, C. N., Niederman, R. A., and Crofts, A. R. (1980). *FEBS Lett.* **115**, 43–48.
- Hong, Y. Q., Förster, V., and Junge, W. (1981). *FEBS Lett.* **132**, 247–252.
- Hope, A. B., and Morland, A. (1979). *Aust. J. Plant Physiol.* **6**, 1–16.
- Horvath, G., Niemi, H. A., Droppa, M., and Faludi-Daniel, A. (1979). *Plant Physiol.* **63**, 778–782.
- Huber, H. L., Rumberg, B., and Siggel, U. (1980). *Ber. Bunsenges. Phys. Chem.* **84**, 1050–1055.
- Isaev, P. I., Liberman, E. A., Samuilov, V. D., Skulachev, V. P., and Tsofina, L. M. (1970). *Biochim. Biophys. Acta* **216**, 22–29.
- Itoh, S. (1978). *Biochim. Biophys. Acta* **504**, 324–340.
- Itoh, S. (1979). *Biochim. Biophys. Acta* **548**, 579–595.
- Jackson, J. B., and Crofts, A. R. (1969). *FEBS Lett.* **4**, 185–188.
- Jackson, J. B., and Crofts, A. R. (1971). *Eur. J. Biochem.* **18**, 120–130.
- Jackson, J. B., and Dutton, P. L. (1973). *Biochim. Biophys. Acta* **325**, 102–113.
- Jackson, J. B., Crofts, A. R., and von Stedingk, L. V. (1968). *Eur. J. Biochem.* **6**, 41–54.
- Jain, M. K. (1972). "The Bimolecular Lipid Membrane." Van Nostrand-Reinhold, Princeton, New Jersey.
- Jasaitis, A. A., Kuliene, V. V., and Skulachev, V. P. (1971). *Biochim. Biophys. Acta* **234**, 177–181.
- Joliot, P., and Delosme, R. (1974). *Biochim. Biophys. Acta* **357**, 267–284.
- Joliot, P., and Kok, B. (1975). In "Bioenergetics of Photosynthesis" (Govindjee, ed.), pp. 388–412. Academic Press, New York.
- Joliot, P., Delosme, R., and Joliot, A. (1977). *Biochim. Biophys. Acta* **459**, 47–57.
- Junge, W. (1968). Thesis, Technische Universität, Berlin.
- Junge, W. (1970). *Eur. J. Biochem.* **14**, 582–592.
- Junge, W. (1972). *Proc. Int. Congr. Photosynth.*, 2nd, 1971 pp. 1065–1074.
- Junge, W. (1977a). In "Photosynthesis I" (A. Trebst and M. Avron, eds.), pp. 59–93. Springer-Verlag, Berlin and New York.
- Junge, W. (1977b). *Annu. Rev. Plant Physiol.* **28**, 503–536.
- Junge, W. (1982). In "Electrogenic Ion Pumps" (C. Slayman, ed.). Academic Press, New York, pp. 431–465.
- Junge, W., and Ausländer, W. (1974). *Biochim. Biophys. Acta* **333**, 59–70.
- Junge, W., and Ausländer, W. (1978). In "Photosynthetic Oxygen Evolution" (H. Metzner, ed.), pp. 213–228. Academic Press, New York.
- Junge, W., and Eckhof, A. (1974). *Biochim. Biophys. Acta* **357**, 103–117.

- Junge, W., and Schaffernicht, H. (1977). In "Photosynthesis '77" (D. O. Hall, J. Coombs, and T. W. Goodwin, eds.), pp. 21–32. Biochem. Soc., London.
- Junge, W., and Schaffernicht, H. (1979). *Ciba Found Symp.* [N.S.] **61**, 127–146.
- Junge, W., and Schmid, R. (1971). *J. Membr. Biol.* **4**, 179–192.
- Junge, W., and Witt, H. T. (1968). *Z. Naturforsch., B: Anorg. Chem., Org. Chem., Biochem., Biophys., Biol.* **23**, 244–254.
- Junge, W., Rumberg, B., and Schröder, H. (1970). *Eur. J. Biochem.* **14**, 575–581.
- Junge, W., Renger, G., and Ausländer, W. (1977). *FEBS Lett.* **79**, 155–159.
- Junge, W., McGeer, A., and Ausländer, W. (1978). In "Frontiers of Biological Energetics" (P. L. Dutton, J. S. Leigh, and A. Scarpa, eds.), Vol. 1, pp. 275–283. Academic Press, New York.
- Junge, W., Ausländer, W., McGeer, A. J., and Runge, T. (1979). *Biochim. Biophys. Acta* **546**, 121–141.
- Jursinic, P., Govindjee, and Wraight, C. A. (1978). *Photochem. Photobiol.* **27**, 61–71.
- Kaufman, K. J., Dutton, P. L., Netzel, T. L., Leigh, J. S., and Rentzepis, P. M. (1975). *Science* **188**, 1301–1304.
- Kell, D. B. (1979). *Biochim. Biophys. Acta* **549**, 55–99.
- Kell, D. B., Ferguson, S. J., and John, P. (1978a). *Biochim. Biophys. Acta* **502**, 111–126.
- Kell, D. B., John, P., Sorgato, M. C., and Ferguson, S. J. (1978b). *FEBS Lett.* **86**, 294–298.
- Klimov, V. V., Dolan, E., and Ke, B. (1980). *FEBS Lett.* **112**, 79–101.
- Knaff, D. B. (1977). *Arch. Biochem. Biophys.* **182**, 540–545.
- Kok, B., Forbush, B., and McGloin, M. (1970). *Photochem. Photobiol.* **11**, 457–475.
- Krause, G. H. (1973). *Biochim. Biophys. Acta* **292**, 715–728.
- Krause, G. H. (1974). *Biochim. Biophys. Acta* **333**, 301–313.
- Kuhn, H. (1979). In "Light Induced Charge Separation in Biology and Chemistry" (H. Gerischer and J. J. Katz, eds.), pp. 151–170. Verlag Chemie, Weinheim.
- Kulandaivelu, G., and Senger, H. (1976). *Biochim. Biophys. Acta* **430**, 94–104.
- Larkum, A. W. D., and Bonner, W. D. (1972). *Biochim. Biophys. Acta* **256**, 396–408.
- Lavorel, J. (1975). In "Bioenergetics of Photosynthesis" (Govindjee, ed.), pp. 223–317. Academic Press, New York.
- Leiser, M., and Gromet-Elhanan, Z. (1977). *Arch. Biochem. Biophys.* **178**, 79–88.
- Liberman, E. A., and Skulachev, V. P. (1970). *Biochim. Biophys. Acta* **216**, 30–42.
- Liptay, W. (1969). *Angew. Chem., Int. Ed. Engl.* **8**, 177–188.
- McLaughlin, S. (1977). *Curr. Top. Membr. Transp.* **9**, 71–144.
- Malkin, R. (1978). *FEBS Lett.* **87**, 329–333.
- Mangel, M., Berns, D. S., and Ilani, A. (1975). *J. Membr. Biol.* **20**, 171–80.
- Mathis, P. (1970). *C.R. Hebd. Seances Acad. Sci.* **271**, 1094–1096.
- Mathis, P., and Havemann, J. (1977). *Biochim. Biophys. Acta* **451**, 167–181.
- Mathis, P., and Vermeglio, A. (1974). *Biochim. Biophys. Acta* **368**, 130–154.
- Mathis, P., and Vermeglio, A. (1975). *Biochim. Biophys. Acta* **369**, 371–381.
- Mathis, P., Breton, J., Vermeglio, A., and Yates, M. (1976). *FEBS Lett.* **63**, 171–173.
- Matsuura, K., and Nishimura, M. (1977). *Biochim. Biophys. Acta* **459**, 483–491.
- Matsuura, M., Masanoto, K., Itoh, S., and Nishimura, M. (1979). *Biochim. Biophys. Acta* **547**, 91–102.
- Matsuura, K., Ishikawa, T., and Nishimura, M. (1980). *Biochim. Biophys. Acta* **590**, 339–344.
- Mercer, F. V., Hedge, A. J., Hope, A. B., and McLean, J. D. (1955). *Aust. J. Biol. Sci.* **8**, 1–18.
- Michels, P. A. M., and Konings, W. N. (1978). *Eur. J. Biochem.* **85**, 147–155.
- Miller, K. R., and Staehelin, L. A. (1976). *J. Cell Biol.* **68**, 30–47.
- Mills, J. D., and Barber, J. (1975). *Arch. Biochem. Biophys.* **170**, 306–314.
- Mitchell, P. (1961). *Nature (London)* **191**, 144–148.

- Mitchell, P. (1966). *Biol. Rev. Cambridge Philos. Soc.* **41**, 445–502.
- Mitchell, P. (1976). *J. Theor. Biol.* **62**, 327–367.
- Möbius, D. (1979). In "Light Induced Charge Separation in Biology and Chemistry" (J. J. Katz and H. Gerischer, eds.), pp. 171–186. Verlag Chemie, Weinheim.
- Mühlethaler, F. (1977). In "Photosynthesis I" (A. Trebst and M. Avron, eds.), pp. 503–521. Springer-Verlag, Berlin and New York.
- Niederman, R. A., and Gibson, K. D. (1978). In "The Photosynthetic Bacteria" (R. K. Clayton and W. R. Sistrom, eds.), pp. 79–118. Plenum, New York.
- Njus, D., Ferguson, S. J., Sorgato, M. C., and Radda, G. K. (1977). In "Structure and Function of Energy Transducing Membranes" (K. Van Dam and B. F. Van Gelder, eds.), pp. 237–250. North-Holland Biomedical Press, Amsterdam.
- Odermatt, E., Snozzi, M., and Bachofen, R. (1980). *Biochim. Biophys. Acta* **591**, 372–390.
- Ort, D. R., Dilley, D. A., and Good, N. E. (1976). *Biochim. Biophys. Acta* **449**, 108–126.
- Ortoide, T. V., Borisevitch, G. P., Venediktov, P. S., and Kononenko, A. A. (1979). *Biochem. Physiol. Pflanz.* **174**, 85–91.
- Packham, N. K., Berriman, J. A., and Jackson, J. B. (1978). *FEBS Lett.* **89**, 205–210.
- Packham, N. K., Greenrod, J. A., and Jackson, J. B. (1980a). *Biochim. Biophys. Acta* **592**, 130–131.
- Packham, N. K., Packham, C., Mueller, P., Tiede, D. M., and Dutton, P. L. (1980b). *FEBS Lett.* **110**, 101–106.
- Petty, K. M., and Dutton, P. L. (1976). *Arch. Biochem. Biophys.* **172**, 335–345.
- Petty, K. M., and Jackson, J. B. (1979a). *Biochim. Biophys. Acta* **547**, 463–473.
- Petty, K. M., and Jackson, J. B. (1979b). *Biochim. Biophys. Acta* **547**, 474–483.
- Petty, K. M., Jackson, J. B., and Dutton, P. L. (1977). *FEBS Lett.* **84**, 299–303.
- Petty, K. M., Jackson, J. B., and Dutton, P. L. (1979). *Biochim. Biophys. Acta* **546**, 17–42.
- Pick, U., and Avron, M. (1976). *FEBS Lett.* **65**, 48–53.
- Polya, G. M., and Jagendorf, A. T. (1969). *Biochem. Biophys. Res. Commun.* **36**, 696–703.
- Portis, A. R., and Heldt, H. W. (1976). *Biochim. Biophys. Acta* **449**, 434–446.
- Portis, A. R., and McCarty, R. E. (1976). *J. Biol. Chem.* **251**, 1610–1617.
- Prince, R. C., and Dutton, P. L. (1975). *Biochim. Biophys. Acta* **387**, 609–613.
- Prince, R. C., and Dutton, P. L. (1977). *Biochim. Biophys. Acta* **462**, 731–747.
- Prince, R. C., Baccarini-Melandri, A., Hauska, G. A., Melandri, B. A., and Crofts, A. R. (1975). *Biochim. Biophys. Acta* **387**, 212–227.
- Prochaska, L. J., and Dilley, R. A. (1978). *Arch. Biochem. Biophys.* **187**, 61–71.
- Pulles, M. P. J., van Gorkom, H. J., and Willemsen, J. G. (1976). *Biochim. Biophys. Acta* **449**, 536–540.
- Quintanilha, A. T., and Packer, L. (1978). *Arch. Biochem. Biophys.* **190**, 206–209.
- Radmer, R., and Cheniaie, G. (1977). In "Primary Processes of Photosynthesis" (J. Barber, ed.), pp. 303–348. Elsevier, Amsterdam.
- Reed, D. W., Raveed, D., and Reporter, M. (1975). *Biochim. Biophys. Acta* **387**, 368–378.
- Reich, R., and Sewe, K. U. (1977). *Photochem. Photobiol.* **26**, 11–16.
- Reinwald, D. E. (1970). Thesis, Technische Universität, Berlin.
- Reinwald, D. E., Stiehl, H. H., and Rumberg, B. (1968). *Z. Naturforsch., B: Anorg. Chem., Org. Chem., Biochem., Biophys., Biol.* **23B**, 1616–1617.
- Remennikov, V. G., and Samuilov, V. D. (1979). *Biochim. Biophys. Acta* **548**, 216–223.
- Renger, G. (1972). *FEBS Lett.* **23**, 321–334.
- Renger, G. (1977). In "Photosynthetic Oxygen Evolution" (H. Metzner, ed.), pp. 229–248. Academic Press, New York.
- Renger, G. L. (1979). *Z. Naturforsch., C: Biosci.* **34C**, 1010–1014.
- Rockley, M. G., Windsor, M. W., Cogdell, R. J., and Parson, W. W. (1975). *Proc. Natl. Acad. Sci. U.S.A.* **72**, 2251–2255.

- Rottenberg, H., Grunwald, T., and Avron, M. (1972). *Eur. J. Biochem.* **25**, 54–63.
- Rumberg, B. (1977). In "Photosynthesis I" (A. Trebst and M. Avron, eds.), pp. 405–415. Springer-Verlag, Berlin and New York.
- Rumberg, G., and Muhle, H. (1976). *Bioelectrochem. Bioenerg.* **3**, 393–403.
- Rutherford, A. W., and Evans, M. C. W. (1980). *FEBS Lett.* **110**, 257–261.
- Saphon, S., and Crofts, A. R. (1977a). *Z. Naturforsch., C: Biosci.* **32C**, 617–626.
- Saphon, S., Jackson, J. B., Lerbs, V., and Witt, H. T. (1975a). *Biochim. Biophys. Acta* **408**, 58–66.
- Saphon, S., Jackson, J. B., and Witt, H. T. (1975b). *Biochim. Biophys. Acta* **503**, 120–134.
- Sauer, K. (1980). *Acc. Chem. Res.* **13**, 249–256.
- Schaffernicht, H., and Junge, W. (1981). *Photochem. Photobiol.* **34**, 223–232.
- Schapendonk, A. H. C. M., and Vredenberg, W. J. (1977). *Biochim. Biophys. Acta* **462**, 613–621.
- Schliephake, W., Junge, W., and Witt, H. T. (1968). *Z. Naturforsch., B: Anorg. Chem., Org. Chem., Biophys., Biol.* **23B**, 1571–1578.
- Schlodder, E., and Witt, H. T. (1980). *FEBS Lett.* **112**, 105–113.
- Schmid, R., and Junge, W. (1975). *Biochim. Biophys. Acta* **394**, 76–92.
- Schmidt, S., Reich, R., and Witt, H. T. (1970). *Naturwissenschaften* **58**, 414–415.
- Schnetkamp, P. P. M., Kaupp, U. B., and Junge, W. (1981). *Biochim. Biophys. Acta* **642**, 213–230.
- Scholes, P., Mitchell, P., and Moyle, J. (1969). *Eur. J. Biochem.* **8**, 450–454.
- Schröder, H., Muhle, H., and Rumberg, B. (1972). *Photosynth., Two Centuries Its Discovery Joseph Priestley, Proc. Int. Congr. Photosynth. Res., 2nd, 1971* pp. 919–930.
- Schuldiner, S., Padan, E., Rottenberg, H., and Gromet-Elhanan, Z., and Avron, M. (1974). *FEBS Lett.* **49**, 174–177.
- Searle, G. F. W., Barber, J., and Mills, J. (1977). *Biochim. Biophys. Acta* **461**, 413–425.
- Sewe, K. U., and Reich, R. (1977). *Z. Naturforsch., C: Biosci.* **32C**, 161–171.
- Shuvalov, V. A., Dolan, E., and Ke, B. (1979). *Proc. Natl. Acad. Sci. U.S.A.* **76**, 770–773.
- Sims, P. J., Waggoner, A. S., Wang, C. H., and Hoffman, J. F. (1974). *Biochemistry* **13**, 3315–3330.
- Slovacek, R. E., Crowther, D., and Hind, G. (1979). *Biochim. Biophys. Acta* **547**, 138–148.
- Stiehl, H. H., and Witt, H. T. (1968). *FEBS Lett.* **39**, 205–208.
- Stiehl, H. H., and Witt, H. T. (1969). *Z. Naturforsch., B: Anorg. Chem., Org. Chem., Biochem., Biophys., Biol.* **24B**, 1588–1598.
- Strichartz, G. R., and Chance, B. (1972). *Biochim. Biophys. Acta* **256**, 71–84.
- Symons, M. (1980). Thesis, Free University of Brussels, Belgium.
- Symons, M., and Crofts, A. R. (1980). *Z. Naturforsch., C: Biosci.* **35C**, 139–144.
- Symons, M., Swysen, C., and Sybesma, C. (1977). *Biochim. Biophys. Acta* **462**, 706–717.
- Symons, M., Nuyton, A., and Sybesma, C. (1979). *FEBS Lett.* **107**, 10–14.
- Takamiya, K., and Dutton, P. L. (1977). *FEBS Lett.* **80**, 279–284.
- Takamiya, K., and Dutton, P. L. (1979). *Biochim. Biophys. Acta* **546**, 1–16.
- Takamiya, K., Prince, R. C., and Dutton, P. L. (1979). *J. Biol. Chem.* **254**, 11307–11311.
- Telfer, A., and Barber, J. (1974). *Biochim. Biophys. Acta* **333**, 343–354.
- Thomas, J. B., Minnaert, K., and Elbers, P. D. (1956). *Acta Bot. Neerl.* **5**, 314–321.
- Thornber, J. P., and Barber, J. (1979). *Top. Photosynth.* **3**, 27–70.
- Thorne, S. W., Horvath, G., Kahn, A., and Boardman, N. K. (1975). *Proc. Natl. Acad. Sci. U.S.A.* **72**, 3858–3862.
- Tributsch, H. (1972). *Photochem. Photobiol.* **16**, 261–269.
- Trissl, H. W. (1980). *Biochim. Biophys. Acta* **595**, 82–95.
- Trissl, H. W., and Gräber, P. (1980). *Biochim. Biophys. Acta* **595**, 96–108.
- Trissl, M. W., Kunze, U., and Junge, W. (1983). *Biochim. Biophys. Acta* (in press).

- Valkirs, G., Rosen, D., Tokuyasu, K. T., and Feher, G. (1976). *Biophys. J.* **16**, 223a.
- van den Berg, W. H., Prince, R. C., Bashford, L., Takamiya, K., Bonner, W. D., and Dutton, P. L. (1979). *J. Biol. Chem.* **254**, 8594–8604.
- Velthuis, B. R. (1978). *Proc. Natl. Acad. Sci. U.S.A.* **75**, 6031–6043.
- Velthuis, B. R. (1979). *Proc. Natl. Acad. Sci. U.S.A.* **76**, 2765–2769.
- Velthuis, B. R. (1980). *FEBS Lett.* **115**, 167–170.
- Velthuis, B. R., and Armesz, J. (1974). *Biochim. Biophys. Acta* **333**, 85–94.
- Vermeiglio, A. (1977). *Biochim. Biophys. Acta* **459**, 516–524.
- Vermeiglio, A., and Mathis, P. (1974). *Biochim. Biophys. Acta* **368**, 9–17.
- Vredenberg, W. J. (1976). In "The Intact Chloroplast" (J. Barber, ed.), pp. 53–87. Elsevier, Amsterdam.
- Vredenberg, W. J., and Tonk, W. J. M. (1975). *Biochim. Biophys. Acta* **387**, 580–587.
- Waggoner, A. (1976). *J. Membr. Biol.* **27**, 317–337.
- Wagner, R., and Junge, W. (1980). *FEBS Lett.* **114**, 327–333.
- Walz, D., Goldstein, L., and Avron, M. (1974). *Eur. J. Biochem.* **47**, 403–407.
- Webster, G. D., Cogdell, R. J., and Lindsay, J. G. (1980). *Biochim. Biophys. Acta* **591**, 321–330.
- Witt, H. T. (1971). *Q. Rev. Biophys.* **4**, 365–477.
- Witt, H. T. (1975). In "Bioenergetics of Photosynthesis" (Govindjee, ed.), pp. 493–354. Academic Press, New York.
- Witt, H. T. (1979). *Biochim. Biophys. Acta* **505**, 355–327.
- Witt, H. T., and Moraw, R. (1959). *Z. Phys. Chem. (Wiesbaden)* [N.S.] **20**, 253–282.
- Witt, H. T., and Zickler, A. (1973). *FEBS Lett.* **37**, 307–310.
- Witt, H. T., and Zickler, A. (1974). *Z. Naturforsch., B: Anorg. Chem., Org. Chem., Biochem., Biophys., Biol.* **25B**, 387–388.
- Witt, K., and Wolff, C. (1970). *Z. Naturforsch., B: Anorg. Chem., Org. Chem., Biochem., Biophys., Biol.* **23B**, 220–224.
- Wolff, C., and Witt, H. T. (1969). *Z. Naturforsch., B: Anorg. Chem., Org. Chem., Biochem., Biophys., Biol.* **24B**, 1031–1037.
- Wolff, C., Buchwald, H. E., Rueppel, H., Witt, K., and Witt, H. T. (1969). *Z. Naturforsch., B: Anorg. Chem., Org. Chem., Biochem., Biophys., Biol.* **24B**, 1038–1041.
- Wolken, J. J., and Schwertz, F. A. (1953). *J. Gen. Physiol.* **37**, 111–120.
- Wraight, C. A. (1977). *Biochim. Biophys. Acta* **459**, 525–531.
- Wraight, C. A. (1978). In "Frontiers of Biological Energetics" (P. L. Dutton, J. S. Leigh, and Scarpa, eds.), Vol. 1, pp. 218–226. Academic Press, New York.
- Wraight, C. A. (1979a). *Photochem. Photobiol.* **30**, 767–776.
- Wraight, C. A. (1979b). *Biochim. Biophys. Acta* **548**, 309–327.
- Wraight, C. A., and Crofts, A. R. (1971). *Eur. J. Biochem.* **19**, 386–397.
- Wraight, C. A., Cogdell, J. R., and Chance, B. (1978). In "The Photosynthetic Bacteria" (R. K. Clayton and W. R. Sistrom, eds.), pp. 471–511. Plenum, New York.
- Yamamoto, Y., and Nishimura, M. (1977). *Plant Cell Physiol.* **18**, 55–66.
- Yamamoto, Y., and Nishimura, M. (1978a). *Plant Cell Physiol.* **19**, 785–790.
- Yamamoto, Y., and Nishimura, M. (1978b). *Plant Cell Physiol.* **19**, 975–983.
- Zannoni, D., and Marrs, B. L. (1978). *Abstr., 5th Annu. Conf. Mol. Biol. Photosynth. Procarvates*, p. 66.
- Zannoni, D., Jasper, P., and Marrs, B. L. (1978). *Arch. Biochem. Biophys.* **191**, 625–631.
- Zannoni, D., Prince, R. C., Dutton, P. L., and Marrs, B. L. (1980). *FEBS Lett.* **113**, 289–293.
- Zickler, A., Witt, H. T., and Boheim, G. (1976). *FEBS Lett.* **66**, 142–148.
- Zürner, H., Snozzi, M., Hanselmann, K., and Bachofen, R. (1977). *Biochim. Biophys. Acta* **460**, 273–279.

Proton Translocating ATPases of Photosynthetic Membranes

RICHARD E. MCCARTY
CHANOCH CARMELI

I. Introduction.....	648
II. Function of ATPase Complexes.....	649
A. Coupling of ATP Hydrolysis and Synthesis to Proton Translocation	649
B. Proton-ATP Stoichiometry.....	652
III. Structure of ATPase Complexes.....	657
A. Coupling Factors.....	657
B. Hydrophobic Components.....	663
C. Reconstitution.....	666
IV. ATPase Activity of Coupling Factors.....	670
A. Properties.....	670
B. Regulation <i>in Vitro</i> and <i>in Situ</i>	675
V. Nucleotide Binding and Conformational Changes.....	681
VI. Postulated Mechanisms.....	688
References.....	690

ABBREVIATIONS

Chl	Chlorophyll
CF ₁	Chloroplast F ₁
DCCD	<i>N,N'</i> -dicyclohexylcarbodiimide
F ₁	For coupling factor 1, a collection of proteins comprising the hydrophilic, extrinsic portion of the ATPase complex
F ₀	The hydrophobic part of the ATPase complex
GTP	Guanosine triphosphate
kD	Kilodalton
NCCD	<i>N</i> -(2,2,6,6-tetramethylpiperidyl-1-oxyl)- <i>N'</i> -cyclohexylcarbodiimide
PMS	<i>N</i> -methylphenazonium methosulfate
PS	Photosystem
RC	Reaction center Chl complex
<i>Rp.</i>	<i>Rhodospseudomonas</i>
<i>Rs.</i>	<i>Rhodospirillum</i>
SDS	Sodium dodecylsulfate
SH	Sulfhydryl

ABSTRACT

Mitchell's (1961, 1966) suggestion that coupling membranes contain a reversible proton-translocating ATPase has gained strong experimental support. The evidence to be

outlined in this chapter will show that the ATPase complexes of photosynthetic membranes are capable of proton-linked ATP synthesis and hydrolysis. ATP synthesis accompanies proton flux down the electrochemical gradient, whereas ATP hydrolysis generates proton gradients.

The ATPase complexes of the photosynthetic membranes of plants and bacteria are remarkably similar. The minimum number of subunits they contain is probably close to 8, and the functions of most of those subunits are largely unknown. Further work by resolution and reconstruction analysis and by selective modification of subunits will aid in the further elucidation of the roles of the subunits. The interactions of the ATPases with nucleotides are very complex and, despite extensive experimentation, the catalytic site(s) of these enzymes is (are) not yet identified.

The mechanisms of ion transport by membrane ATPases are largely unknown and an important problem in bioenergetics of photosynthesis is how ATPase complexes work. To accomplish this goal, further information about the structure of these complicated enzymes and of the mechanism of the ATPase activity of the soluble portion of the complexes will be required.

I. Introduction

Photosynthetic phosphorylation, the light-dependent synthesis of ATP, is catalyzed by an enzyme complex that is a part of the membranes of chloroplasts and photosynthetic bacteria. As Mitchell (1961, 1966) suggested 2 decades ago, this complex couples ATP synthesis and hydrolysis to proton movements. The flow of protons down their electrochemical gradient, generated by light-dependent electron flow, drives ATP synthesis. (For earlier reviews, see Jagendorf (1975) and Witt (1975).) The reverse reaction, ATP hydrolysis to ADP and P_i , is accompanied by proton translocation in the direction opposite to that which occurs during ATP synthesis. That is, ATP hydrolysis can also cause the generation of an electrochemical proton gradient. Mitchell (1961) called the enzyme complex that catalyzes this reaction "the reversible proton translocating ATPase [p. 145]." It is also denoted as the ATPase complex, H^+ -ATPase (in analogy to the Na^+, K^+ -ATPase), F_1-F_0 , and ATP synthase. Eventually, some consensus as to the nomenclature of this important class of enzymes will be reached. The use of the term ATP synthase suffers from the disadvantage that it obscures the fact that similar enzymes function in anaerobic bacteria and in plant vacuolar membranes to generate proton gradients by ATP hydrolysis.

In the early stages of research on the enzymes required for oxidative and photosynthetic phosphorylation, the approach used was to attempt to resolve the system into as many components as possible and then to reconstitute it. This approach resulted in a multiplicity of proteins that were apparently required for oxidative phosphorylation in mitochondria and one protein required for photophosphorylation in chloroplasts.

These proteins were given the operational name of *coupling factors* since they restored ATP synthesis to the existing electron flow. That is, they caused a recoupling of phosphorylation to electron transport. Racker (1979) reviewed the status of these factors, named F_1 , F_2 , . . . , in mitochondria. In analogy to the first mitochondrial coupling factor, F_1 , the chloroplast coupling factor was denoted CF_1 . Similar proteins from the coupling membranes of bacteria are often named for the species from which they were prepared. For example, *E. coli* F_1 is called ECF_1 and *Rs. rubrum* F_1 is called RrF_1 .

ATPase complexes contain an oligomeric, hydrophilic protein and a collection of much more hydrophobic polypeptides that seem to be integral parts of the membranes. The hydrophilic protein is the F_1 component, an extrinsic membrane protein that may be readily removed from the membrane without destruction of either the F_1 or the membranes. In contrast, the hydrophobic components of the complex may be resolved from the membrane only through the use of detergents or organic solvent extraction. This collection of hydrophobic polypeptides is often denoted F_o , in analogy to a crude detergent extract of mitochondrial membranes that restored sensitivity of the ATPase activity of soluble F_1 to the inhibitor, oligomycin (Racker, 1979). Thus, it may be seen why the ATPase complex is also called F_1-F_o (or CF_1-F_o).

In this chapter, the structure, function, and possible mechanisms of the ATPase complex from photosynthetic membranes will be outlined. On occasion, studies on the ATPase complexes from nonphotosynthetic membranes will be referred to, but the emphasis will be on the role of the complex in photophosphorylation. The comprehensive review by Senior (1979) and that on the reconstitution of oxidative phosphorylation in a thermophilic bacterium by Kagawa (1978) may be consulted for further information on the ATPase complex in oxidative phosphorylation. Moreover, a number of reviews on coupling factors and ATPase complexes in photophosphorylation have been done (Nelson, 1976; McCarty, 1978a, 1979a; Baird and Hammes, 1979). Although some duplication is unavoidable, we have attempted to emphasize more current results and ideas in this chapter.

II. Function of ATPase Complexes

A. Coupling of ATP Hydrolysis and Synthesis to Proton Translocation

A reversible proton ATPase is expected to synthesize ATP from a transmembrane electrochemical potential of protons ($\Delta\bar{\mu}_{H^+}$) and to

create a $\Delta\bar{\mu}_{H^+}$ during ATP hydrolysis (Mitchell, 1966). Protons should be the primary ion pumped by the ATPase and should be involved in the early events of ATP synthesis. They should be a major component not only in the initiation but also during steady state synthesis and hydrolysis of ATP. Thus, it would be expected that a definite stoichiometry between protons and ATP, both at the initial rate and at steady state, would be an expression of the mode of action of these reactions.

These are the major requirements that could establish the existence of coupling between protons and the function of ATPase in oxidative and photosynthetic phosphorylation. Most of these criteria were looked for in chloroplasts from higher plants and in membrane vesicles (chromatophores) from photosynthetic bacteria. To variable degrees of precision and certainty, most of these features were demonstrated. The outstanding finding of a light-induced pH change in thylakoid suspensions (Jagendorf and Hind, 1963) demonstrated the possible role of protons as an intermediate of energy transfer in chloroplasts. Neumann and Jagendorf (1964) demonstrated that the pH changes are a result of a reversible proton movement across the thylakoid membrane since uncoupler, which increased membrane conductance to protons, dissipated the pH changes and inhibited photophosphorylation. Similar observations were obtained for chromatophores of the bacterium *Rhodospirillum (Rs.) rubrum* (von Stedingk and Baltscheffsky, 1966).

The light-induced proton movement was found to be the primary event in ion movement and electrogenic in nature since permeant anion (such as chloride) influx and cation efflux (such as Mg^{2+} , K^+) stoichiometrically compensate for the proton influx in chloroplasts. The cations and anions are of wide specificity and, therefore, their movement is unlikely to be the primary event in the generation of $\Delta\bar{\mu}_{H^+}$ (Hind *et al.*, 1974). A less comprehensive study indicated that in chromatophores added potassium exchanges in the presence of valinomycin against the primary movement of protons (Jackson *et al.*, 1968). Anions such as nitrate and iodide, which are more permeable, increased the rate of light-induced proton movement probably by decreasing the membrane potential formed by the electrogenic proton movement. (For a discussion of membrane potential, see Junge and Jackson, Chapter 13, this volume.) The steady state rate of proton uptake is compatible with the rate of electron transport (Jackson and Crofts, 1969). (For a discussion of electron and proton transport, see Cramer and Crofts, Chapter 9, this volume.) Measurements of the initial rate of proton movement in chloroplast thylakoids and in chromatophores are comparable with the rate of electron transport and fast enough to account for the rate of photophosphorylation. The fast single turnover flash-induced binding of

protons in chromatophores was found to be uncoupler insensitive, but the rate of its decay was stimulated by uncouplers as is expected from electrogenic movement of protons (Chance *et al.*, 1970). The flash-induced proton binding was resolved to at least two kinetic components (with half-rise times between 130–400 μ sec). Both were too slow to be correlated to the oxidation of the primary electron acceptor but too fast for the reduction of the secondary electron acceptor. However, potentiometric measurements indicated that at least one component of the proton binding could be a result of proton transfer by ubiquinone (Cogdell *et al.*, 1972). In any event the initial rate of proton uptake is adequate to account for the rate of photophosphorylation in bacteria. (For a discussion of the mechanism of phosphorylation, see Ort and Melandri, Chapter 12, this volume.)

In chloroplasts the initial rate of proton release inside the thylakoid occurs at two sites. One site with a half-rise time of about 0.3 msec corresponds to the photolytic reaction of the water system and a second at 18 msec is related to the oxidation of plastoquinone (Ausländer and Junge, 1975). Considering the abundance of plastoquinone in the electron transport chain, the initial rate of proton release at the second site could not account for the rate of photophosphorylation, which has a half-life time of 2.5 msec *in vivo* (Heber, 1973). A possible control of proton movement through the lipid bilayer could be the cause for this discrepancy.

The clearest evidence for coupling between ATP synthesis and $\Delta\mu_{H^+}$ comes from experiments done by Hind and Jagendorf (1965) in which ATP synthesis was generated by transferring chloroplasts from pH 4 to 8 in the dark. The initial rate of ATP synthesis was comparable to the initial rate of photophosphorylation that takes place under similar experimental conditions (Smith *et al.*, 1976). In chromatophores, acid-base transitions did not by themselves support phosphorylation, but they did enhance ATP synthesis generated by artificial membrane potentials created by chemical potential difference of potassium ions in the presence of valinomycin (Leiser and Gromet-Elhanan, 1974).

Proton uptake induced by ATP hydrolysis in thylakoids (Carmeli, 1970) and in chromatophores (Mitchell, 1967) in the dark has been demonstrated. The formation of a Δ pH during ATPase activity induced amine uptake by thylakoids (Crofts, 1966; Gaensslen and McCarty, 1971). ATP hydrolysis by chloroplasts supports a Δ pH of close to three units, as estimated by amine uptake (Bakker-Grunwald and van Dam, 1973). This value is lower than the Δ pH obtained during light-induced electron transport in part because only partial activation of ATPase in chloroplasts can be achieved by the light-triggering technique. In chro-

matophores, ATP induced atebtrin fluorescense quenching (Melandri *et al.*, 1972) and uptake of permeable cations (Isaev *et al.*, 1970). Although these effects are likely to be caused by the formation of electrochemical proton gradients, no quantitative estimation was attempted in these experiments. A comprehensive study of the kinetics and the stoichiometry of proton uptake during ATP hydrolysis could yield valuable information regarding the mechanism of the reversible proton ATPase in photosynthetic bacteria.

Exchange reactions catalyzed by the ATPase complex which are supported by $\Delta\bar{\mu}_{H^+}$ formed by ATP hydrolysis are another expression of the coupling between protons and the catalysis of ATP synthesis. Uncoupler-sensitive P_i -ATP exchange (Carmeli and Avron, 1966; McCarty and Racker, 1968), $H_2^{18}O$ -ATP and P_i - $H_2^{18}O$ exchanges (Skye *et al.*, 1967) are catalyzed by the chloroplast ATPase. An uncoupler sensitive P_i -ATP exchange was also demonstrated in chromatophores (Horio *et al.*, 1965; Keister and Minton, 1971). P_i -ATP exchange in chloroplasts probably is the result of the synthesis of ATP from medium P_i and ADP, a reaction driven by the ΔpH generated by ATP hydrolysis (Davenport and McCarty, 1981).

B. Proton-ATP Stoichiometry

Although it is generally accepted that the ATPase complex of photosynthetic membranes can function as a reversible proton translocator, the number of protons translocated per ATP formed or hydrolyzed (the H^+/ATP ratio) is not established with certainty. This ratio, which assumes importance in considerations of the energetics and mechanism of the ATPase reaction, has been estimated in a number of different ways in photosynthetic membranes from a variety of organisms. The values obtained range from about 2 to 4 H^+/ATP . The methods used to estimate H^+/ATP ratios are, however, not without their problems. Moreover, it is not impossible that the apparent proton stoichiometry of the complex might vary from organism to organism.

One of the most common approaches to the estimation of H^+/ATP ratios is to attempt to bring the phosphorylation system into equilibrium with the electrochemical proton gradient. Under these conditions, in principle, $-(H^+/ATP) \cdot \Delta G_{H^+} = \Delta G'_{\Delta TP}$, where ΔG_{H^+} and $\Delta G'_{\Delta TP}$ are the Gibb's free energy change of the electrochemical proton gradient and of ATP synthesis, respectively. The $\Delta G'_{\Delta TP}$ may be calculated from the expression

$$\Delta G'_{\text{ATP}} = \Delta G^{\circ'}_{\text{ATP}} + RT \ln \frac{[\text{ATP}]}{[\text{ADP}][\text{P}_i]}$$

where $\Delta G^{\circ'}_{\text{ATP}}$ is the standard free-energy change for the reaction under the conditions in which the reaction is carried out; R , the gas constant; T is the absolute temperature, and the concentrations are given in molarities. Although this seems relatively straightforward, different laboratories have obtained slightly different values of $\Delta G^{\circ'}_{\text{ATP}}$. Moreover, it may be questioned whether the system is at equilibrium even though the phosphorylation of ADP appears to cease. The translocation of protons through a leakage pathway and ATPase activity that is not coupled to proton transport would also influence the results. If nonequilibrium thermodynamics were to apply to this situation, the ratio of $\Delta G'_{\text{ATP}}/\Delta G_{\text{H}^+}$ may have a different meaning.

Perhaps a more significant problem with this approach concerns the precise measurement of ΔG_{H^+} . Since the electrochemical proton gradient consists of both an activity and an electrical gradient (membrane potential), both terms must be measured to allow the calculation of ΔG_{H^+} . In chloroplast thylakoids, the membrane potential ($\Delta\psi$) is quite low at the steady state of illumination and, thus, only the proton activity gradient (ΔpH) need be estimated. In chromatophore preparations, however, a substantial $\Delta\psi$ and ΔpH exist under most conditions. There is no doubt that substantial electrochemical proton gradients are established by electron flow in thylakoids and chromatophores. There are, however, quantitative differences in the size of these gradients, depending on the techniques used to estimate them. $\Delta\psi$ has been estimated in chromatophores from photosynthetic bacteria from the distribution of permeant anions (Leiser and Gromet-Elhanan, 1977), from calibration of the carotenoid band shift (Casadio *et al.*, 1974) and with dyes the fluorescence of which responds to membrane potential (Gromet-Elhanan and Leiser, 1978). K^+ diffusion potentials established in the dark in the presence of the K^+ ionophore, valinomycin, are used to calibrate the response of the carotenoids or dyes to $\Delta\psi$. However, both the dyes and the carotenoids are likely to respond to changes in surface potentials in the light (Junge, 1977), resulting in an overestimation of the transmembrane $\Delta\psi$. In contrast, $\Delta\psi$ may be underestimated by the anion distribution method since the high chromatophore concentrations used in these experiments may lead to light limitation.

The distribution of radioactive and fluorescent amines and of NH_4^+ is used to estimate ΔpH . Provided that care is taken to prevent light limitation during the uptake assays, similar values for ΔpH are obtained

from amine and NH_4^+ distributions. In contrast, ΔpH values calculated from the distribution of 9-aminoacridine, determined by assuming that the fluorescence of the accumulated amine is totally quenched (Schuldiner *et al.*, 1972), are uniformly higher, especially at high light intensities. The use of 9-aminoacridine fluorescence quenching as a quantitative measure of ΔpH has been criticized (Fiolet *et al.*, 1974).

Table I shows values obtained for ΔG_{H^+} and $\Delta G'_{\text{ATP}}$ in both chromatophores from various photosynthetic bacteria and chloroplasts from lettuce or spinach. In *Rp. capsulata* chromatophores, rather high ΔG_{H^+} values have been estimated using the carotenoid band shift for the estimation of $\Delta\psi$ and 9-aminoacridine fluorescence quenching, for ΔpH (Casadio *et al.*, 1974). Much lower values were obtained in *Rs. rubrum* chromatophores when ΔpH was calculated from the distribution of methylamine, and $\Delta\psi$ was calculated from SCN^- uptake (Gromet-Elhanan and Leiser, 1978). Somewhat higher values were calculated using fluorescent probes. In any case, the data were most consistent with at least $3\text{H}^+/\text{ATP}$ for *Rs. rubrum* chromatophores and for chloroplasts. The *Rp. capsulata* data, in contrast, suggest that only $2\text{H}^+/\text{ATP}$ may be required. At very low light intensities, $2\text{H}^+/\text{ATP}$ appeared to be insufficient to drive phosphorylation (Baccarini-Melandri *et al.*, 1977). It may well be that ΔpH and $\Delta\psi$ are overestimated by the methods used to determine these parameters in *Rp. capsulata*, especially at higher light intensities.

More direct means for estimating H^+/ATP ratios have also been attempted. One of the earliest measurements in chloroplasts (Schwartz, 1968) was accomplished by a comparison of the steady state rate of ATP synthesis to that of proton efflux immediately after switching off the light. Because of the likely formation of a reverse $\Delta\psi$ due to rapid H^+ efflux, the H^+/ATP ratio of 2 calculated by Schwartz is low. In support of this idea, Schröder *et al.* (1972) found that the H^+/ATP ratio obtained by this method was close to 3 when valinomycin and K^+ were added to prevent the rate limitation of proton efflux in the dark by the reverse $\Delta\psi$. In *Rs. rubrum* chromatophores, Saphon *et al.* (1975) measured the flash-induced dark decay of the carotenoid band shift and acidification of the medium by spectral shifts of a pH indicator. Assuming the magnitude of the ADP-stimulated portion of the carotenoid shift was a measure of the total H^+ efflux due to ATP synthesis, they calculated an H^+/ATP ratio of close to 2.

Although the ATPase activity of washed chloroplast thylakoids is low, illumination of thylakoids in the presence of sulfhydryl compounds induces this activity (Petrack *et al.*, 1965). ATP hydrolysis continues in the

TABLE I
 ΔG_{H^+} and ΔG_{ATP} Estimates in Photosynthetic Membranes^a

Membrane	ΔpH (mV)	Method used	$\Delta\psi$ (mV)	Method used	ΔG_{H^+} (mV)	ΔG_{ATP} (mV)	Calculated H^+/ATP
Lettuce thylakoids ^b	238	Quenching of 9-AA ^c fluorescence	<10	Anion uptake	238	608	2.6
Spinach thylakoids ^c	198	Hexylamine uptake	<10	Anion uptake	198	617	3.1
<i>Rp. capsulata</i> chromatophores ^{d,e}	190	Quenching of 9-AA fluorescence	227	Carotenoid band shift	417	668	1.6
<i>Rs. rubrum</i> chromatophores ^f	136	Quenching of 9-AA fluorescence	64	Fluorescent probes	200	543	2.7
<i>Rs. rubrum</i> chromatophores (nonphosphorylating conditions)	148	Quenching of 9-AA fluorescence	110	Fluorescent probes	258	—	—
	108	Methylamine uptake	89	SCN ⁻ uptake	197	—	—

^aMembranes were illuminated to obtain steady state phosphorylation (unless otherwise indicated) at light intensities close to saturating for cyclic phosphorylation. ΔpH , $\Delta\psi$, and ΔG_{H^+} were estimated in the same experiment under identical conditions.

^bAvron (1978).

^cMcCarty (1978b).

^dCasadio *et al.* (1974).

^eAverage of three experiments.

^fLeiser and Gromet-Ehmanan (1977) and Gromet-Ehmanan and Leiser (1978).

89-AA stands for 9-aminoacridine.

dark after activation and is coupled to inward proton translocation. By comparison of the initial rates of ATP hydrolysis to those of proton uptake, H^+/ATP ratios from about 2 to 4 have been estimated (Carmeli *et al.*, 1975). It is difficult to obtain accurate assessments of initial proton uptake rates supported by ATP hydrolysis because of the slow response of the glass electrode. The use of indicators to measure proton uptake would seem to be preferable, but ATP causes changes in light scattering by the thylakoid suspension, which interfere with the measurements. Using suboptimal conditions for ATPase activation to slow the rate of proton uptake, an H^+/ATP of roughly 3 was calculated by a comparison of the initial rate of proton uptake to the steady state rate of ATP hydrolysis, determined from proton release by the reaction at pH 8 (McCarty, 1978b).

The stoichiometries of the proton translocating elements of coupling membranes must be consistent with the maximum phosphorylation efficiency (P/e_2). That is, the ratio of protons translocated per electron pair traversing the chain (H^+/e_2) divided by the H^+/ATP ratio gives the maximum phosphorylation efficiency:

$$\frac{H^+/e_2}{H^+/ATP} = P/e_2$$

Since electron flow in bacterial chromatophores is cyclic, it is difficult to estimate steady state rates of electron transport. In chloroplasts, however, both linear and cyclic electron flow can occur. Under the appropriate conditions, for example in the presence of ferricyanide, cyclic electron transport is suppressed and linear electron flow from H_2O to ferricyanide occurs. Both photosystems are involved in this electron flow. Various lines of evidence suggest that four protons appear in the thylakoid internal space per electron pair traversing the chain from H_2O to ferricyanide (Junge, 1977). That is, this electron transport pathway has an H^+/e_2 ratio of 4.

Measured P/e_2 values for linear electron flow from H_2O to ferricyanide generally range from slightly less than to slightly greater than 1.0. Values as high as 1.7 have been obtained in thylakoids from freshly lysed intact chloroplasts, but these high values have not been confirmed in other laboratories. The maximum P/e_2 ratio is likely to be higher than the measured values. Some proton efflux that is not coupled to ATP synthesis occurs and to obtain the maximal P/e_2 ratio, a correction for this proton leak must be made. The finding that this passive efflux rate

is proportional to the internal proton concentration (Portis *et al.*, 1975) provided a means for extrapolating the maximum P/e_2 ratio from the data of experiments in which phosphorylation, ΔpH and electron transport were measured as a function of light intensity, various concentrations of inhibitors, and of P_i (McCarty and Portis, 1976; Portis and McCarty, 1976; Davenport, 1982). In over 75 experiments, the extrapolated maximum P/e_2 averaged 1.25 ± 0.1 . This result suggests that the H^+/ATP ratio is 3, since the maximum P/e_2 is close to $4/3$. Moreover, the maximum P/e_2 ratio for phosphorylation coupled to electron flow through photosystem (PS) I alone was close to $2/3$, a finding consistent with an H^+/e_2 of 2 for this system and an H^+/ATP of 3. The apparent dependence of the rate of photophosphorylation on the cube of the internal concentration (Portis and McCarty, 1974) is also consistent with an H^+/ATP ratio of 3.

An H^+/ATP ratio of 3 for the chloroplast ATPase complex seems most consistent with the data. For bacterial ATP complexes this ratio is more controversial. The possibilities that the stoichiometry of the complex varies from organism to organism and with assay conditions cannot, however, be excluded. Further refinements in the preparation of photosynthetic membranes may be required before the true proton stoichiometries of the ATPase complexes can be ascertained. For further discussion, see Ort and Melandri, Chapter 12, this volume.

III. Structure of ATPase Complexes

A. Coupling Factors

Based on the early finding that dilute EDTA solutions uncoupled photophosphorylation by thylakoids (Jagendorf and Smith, 1962) by partial but reversible removal of a protein factor (Avron, 1963), the most widely used method for purification of CF_1 was developed (McCarty and Racker, 1966; Lien and Racker, 1971a). Reversible removal and purification of CF_1 also was done by pyrophosphate washing (Strotmann *et al.*, 1973). In addition, isolation of CF_1 was achieved by extraction of acetone-precipitated thylakoids with aqueous buffers (Vambutas and Racker, 1965) and by chloroform extraction (Younis *et al.*, 1977). However, the use of organic solvents destroys the chloroplast membrane. Similar methods were used for removal and isolation of F_1 from chromatophores, but the techniques used varied among the various species of photosynthetic bacteria. Acetone powder was used for purification of

F_1 from *Rp. capsulata* (Baccarini-Melandri and Melandri, 1971) and *Rs. rubrum* (Johansson *et al.*, 1973), whereas chloroform extraction yielded F_1 from *Rs. rubrum* (Webster and Jackson, 1978; Muller *et al.*, 1979) and from the cyanobacterium *Mastigocladus laminosus* (Binder and Bachofen, 1979). Incubation of chromatophores of *Chromatium (Chr.) vinosum* in low salt solution yielded complete, reversible removal (Hochman and Carmeli, 1971) of F_1 (Gepshtein *et al.*, 1978). Partial removal and purification of F_1 was obtained by passage of *Rs. rubrum* chromatophores through a French press (Lucke and Klemme, 1976). Treatment with 10 mM EDTA resulted in partial removal of F_1 from chromatophores of the cyanobacterium *Spirulina platensis* (Owers-Narhi *et al.*, 1979).

The molecular weight of CF_1 from chloroplasts was estimated to be 325,000 by sedimentation equilibrium centrifugation (Farron, 1970) and by small-angle X-ray and light scattering (Paradies *et al.*, 1978). However from low speed centrifugation a value of 417,000 was determined (Yoshida *et al.*, 1979); this high value could be a result of the presence of 10% methanol in the medium. CF_1 is cold labile; however, either ATP or ADP and other tri- and diphosphonucleosides plus Mg^{2+} prevent cold inactivation (Posorske and Jagendorf, 1976).

F_1 from photosynthetic bacteria seems to be less cold labile than CF_1 , but the degree of lability varies among the species. Thus, *Rs. rubrum* F_1 is slightly more labile at 0° than at 30°C and ATP or salt has no effect on these properties (Johansson *et al.*, 1973). *Chromatium* F_1 (Gepshtein and Carmeli, 1977) and *M. laminus* F_1 (Binder and Bachofen, 1979) are more cold labile and are more responsive to ATP stabilization. Equilibrium sedimentation measurement gave a molecular weight of 350,000 for *Rs. rubrum* F_1 (Johansson *et al.*, 1973). A similar value was estimated from gel filtration studies for *Rs. rubrum* (Lucke and Klemme, 1976) and for F_1 from *Rp. capsulata* (Melandri *et al.*, 1971). A molecular weight of 400,000 was estimated for *Rs. rubrum* F_1 extracted by chloroform (Muller *et al.*, 1979). However, the results obtained by this method could not be taken as conclusive.

1. SUBUNIT STRUCTURE

The F_1 's from chloroplasts (Racker *et al.*, 1972) and chromatophores (Johansson *et al.*, 1973; Gepshtein *et al.*, 1978) are composed of five different subunits as resolved by SDS gel electrophoresis. The polypeptides are designated according to their size as $\alpha, \beta, \gamma, \delta$, and ϵ with molecular mass (in kD) estimated for CF_1 subunits of between 59–61 for α , 54–57 for β , 34–39 for γ , 17–20.8 for δ , and 13–15.7 for ϵ (Nelson *et al.*, 1973; Baird and Hammes, 1976; Binder *et al.*, 1978). In F_1 from *Rs. rubrum* chromatophores, estimation of the molecular mass of the various

polypeptides is similar in magnitude but varies between 54–58, 50–53, 32–39, 13–18.5, and 7.5–14 kD for α , β , γ , δ , and ϵ subunits, respectively (Johansson and Baltscheffsky, 1975; Bengis-Garber and Gromet-Elhanan, 1979; Muller *et al.*, 1979). The inherent error for the estimation of molecular mass by SDS-gel electrophoresis can probably account for the variations in the results, especially for the smaller polypeptides. Three independent measurements gave the subunit stoichiometry 2α , 2β , γ , δ , and 2ϵ for CF_1 . The first method involved measurement of the relative distribution of radioactivity among the subunits of CF_1 isolated from chloroplast of pea plants grown under $^{14}CO_2$ atmosphere (Nelson, 1976). In the second method, five different cross-linking reagents were reacted with CF_1 , and the resulting aggregates were resolved on SDS gel electrophoresis (Baird and Hammes, 1976). In the third approach, Coomassie blue staining of the individual purified subunits was used to quantitate their relative amounts on SDS gels of the intact CF_1 (Binder *et al.*, 1978). From determination of the distribution of sulfhydryl (SH) content in the various subunits, a similar stoichiometry of the subunits of CF_1 was deduced (Binder *et al.*, 1978). However these results vary in the total number and the detailed subunit location of the SH's when compared to earlier measurements (Nelson, 1976). The detailed amino acid composition of CF_1 (Nelson, 1976) varies slightly from that of F_1 from chromatophores (Muller *et al.*, 1979). The content of amino acids in the individual subunits of F_1 from chromatophores has yet to be established.

Results obtained from small-angle X-ray scattering experiments indicated that CF_1 is ellipsoidal with axial ratio of 1.2 and a diameter of 100 Å (Paradies *et al.*, 1978). From cross-linking experiments, Baird and Hammes (1976) suggested that this ellipse is constructed from a middle section, which consists of an alternative arrangement of 2α and 2β subunits. In the middle and slightly on top is situated the γ subunit, whereas 2ϵ are attached to the α , β , and γ subunits. The δ subunit is attached to the γ subunits from the bottom and connects CF_1 to F_0 in the membrane as indicated from reconstitution studies (Nelson and Karny, 1976; Younis *et al.*, 1977). The absence of cross-linking between the δ and γ subunits could have resulted from conformational changes that renders γ less chemically reactive in the isolated CF_1 . Indeed, pyridoxal phosphate, which interacted with α , β , and γ subunits of the membrane bound CF_1 , chemically modified the α and β subunits alone in the soluble enzyme (Sugiyama and Mukohata, 1978, 1979a). In contrast to antibodies against α and β subunits, antibodies against the γ , δ and ϵ subunits failed to agglutinate chloroplasts; this was taken to indicate a slightly different arrangement of the subunits of CF_1 (Nelson *et al.*, 1973). These authors suggested that all the three smaller subunits are located on the

membrane side of CF_1 . Steric hindrance, however, may prevent cross-linking required for agglutination.

The shape of the two smaller subunits was also studied by small-angle X-ray scattering. The δ subunit has an elongated elliptical shape ($100 \times 25 \times 28 \text{ \AA}$) (Schmidt and Paradies, 1977b), whereas ϵ is a compact sphere ($12.7 \times 12.7 \times 25.4 \text{ \AA}$) (Schmidt and Paradies, 1977a). A model for the arrangement of CF_1 subunits based on the work of Baird and Hammes (1979) is shown in Fig. 1.

2. FUNCTION OF THE SUBUNITS

There are several indications that the catalytic site might be located on the β subunit. Early results showed that chemical modification of a tyrosyl residue on the β subunit by NBD-Cl inhibits ATPase activity (Deters *et al.*, 1975) and the binding of adenylymidodiphosphate to a binding site exposed by heat treatment in CF_1 (Cantley and Hammes, 1975a). Binding of only one mole of NBD-Cl per CF_1 was sufficient for complete inhibition of the activity in spite of the existence of at least two β subunits per CF_1 . A cooperative interaction between the β subunits could explain these results. Indeed, a considerable conformational change was observed in CF_1 when modified by NBD-Cl (Holowka and Hammes, 1977). Selective removal by LiCl treatment and reconstitution of β subunit of F_1 of *Rs. rubrum* chromatophores (Philosoph *et al.*, 1977) gave strong support for the essential role of this subunit in the catalysis of ATPase and ATP synthesis. Reconstitution of F_1 from a thermophilic bacterium from the individual subunits showed that no ATPase activity can be obtained unless the β subunit is present (Kagawa, 1978).

Other studies point to the possibility that the active site is located on

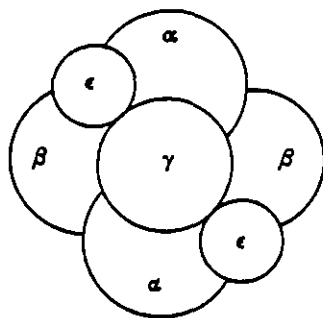

FIG. 1. A proposed structure for CF_1 . This structure is based on the cross-linking studies and fluorescence energy-transfer experiments, summarized in Baird and Hammes (1979) and is taken from McCarty (1979a). The view of the CF_1 is from the top, with the membrane in the plane of the paper. The δ subunit is not visible in this view. The γ and ϵ subunits may not be as exposed as shown here, since they are relatively resistant to attack by a variety of proteases (J. V. Moroney and R. E. McCarty, 1981).

the β subunit, but do not rule out the candidacy of the α subunit. Thus, after prolonged tryptic digestion, α and β subunits are left, whereas ATPase activity is not impaired (Deters *et al.*, 1975). Although this preparation did not cross react with an antiserum against γ , it is still possible that an essential fragment of this subunit that lacks the antigenic site remains functional. Indeed, after trypsin treatment of F_1 from *E. coli*, a fragment of γ together with α and β subunits are present (Smith and Wilkonski, 1978). Chemical modification of CF_1 by pyridoxal phosphate, which probably modifies lysyl residues, inhibited ATPase activity (Sugiyama and Mukohata, 1979a,b). In this study it was found that 50% inhibition is reached when 0.5 mole of the reagent is bound to each of the α and β subunits. Oxidation of sulfhydryl groups, two on each of the β and γ subunit, caused inhibition of ATPase and of photophosphorylation (Andreo *et al.*, 1979). This chemical modification occurred during heat activation of soluble CF_1 or during light activation of the membrane bound enzyme. All of these experiments indicate not only the central role of the β subunit in catalysis, but also the involvement of the α and γ subunits in this process. However, further evidence points to the possibility that the α and γ subunits have a role in regulation of the catalysis.

Among the best evidence for the possible involvement of the α subunit in regulation is derived from results obtained from immunological studies. Antibody against the α subunit prevented the modulation of proton conductance through the thylakoid membrane by low ATP concentrations (Nelson *et al.*, 1973). The high affinity binding sites for nucleotides, which were proposed to be regulatory (McCarty, 1979b), might be located on this subunit. The fact that these sites are 40 Å away from the NBD-Cl binding site on the β subunit could also place them on the α subunit (Cantley and Hammes, 1975b). It is possible, however, that the α subunit has a more intimate role in catalysis since antibody against this subunit inhibited phosphorylation and ATPase activity catalyzed by the membrane bound CF_1 , whereas anti- α plus anti- γ inhibited ATP hydrolysis in the isolated enzyme (Nelson *et al.*, 1973). It may be relevant that in bacterial TF_1 tight binding sites for ADP were identified on the isolated α subunit (Kagawa *et al.*, 1979).

The γ subunit might serve as a gate for the protons that are conducted through F_o and seems to have an important regulatory function in the ATPase complex. The observed stimulation of the light-induced pH change following interaction of thylakoids with anti- γ serum could indicate a role of this subunit as a gate for proton conductance through F_o (Nelson *et al.*, 1973). Indeed, reconstitution studies with TF_1-F_o complex clearly showed that the γ subunit was essential for gating proton

channel in thermophilic bacteria (Yoshida *et al.*, 1979). Although modification of the γ subunit in CF_1 by *N*-ethylmaleimide does not alter proton permeability, it prevents the effect of ATP on proton conductance (McCarty *et al.*, 1972). The effect of ATP may be transmitted from the α subunits to the γ subunit which serves as a gate. Further support for this suggestion is drawn from the observation that the light-induced modification of this subunit by *N*-ethylmaleimide is partially prevented in the presence of adenine nucleotides (Magnusson and McCarty, 1975). Light-induced maleimide inhibition of photophosphorylation, and the partial protection by adenine nucleotides was also observed in chromatophores from *Rp. capsulata* (Baccarini-Melandri *et al.*, 1975). Conformational changes are certainly a way through which regulation of biochemical processes can be achieved. It is not surprising that $\Delta\bar{\mu}_{H^+}$ induces conformational changes in the γ subunit as expressed by the chemical modification of SH groups with maleimides and *o*-iodosobenzoate (Andero *et al.*, 1979), possibly of lysyl residues by pyridoxal phosphate (Sugiyama and Mukohata, 1978) and by trinitrobenzenesulfonate (Oliver and Jagendorf, 1976).

As discussed earlier, it seems that the γ subunit serves not only as a gate of proton transfer through F_o , but has also an important function in regulation of photophosphorylation and ATPase activity both in the membrane bound and in the isolated CF_1 . It is possible, therefore, that this subunit either mediates proton movement within the enzyme or mediates changes induced by protons that come either through F_o or from the catalysis of ATP hydrolysis.

Additional gating mechanisms of the F_1 sector might exist in chromatophores. Proton conductance was only slightly altered in *Rp. capsulata* chromatophores partially depleted from F_1 (Melandri *et al.*, 1972) and in completely resolved chromatophores from *Chromatium* (A. Gepshtein and C. Carmeli, unpublished observation). Aging caused a decrease in proton conductance in thylakoid membranes that were completely depleted of CF_1 by NaBr treatment (Nelson and Hauska, 1979).

Binding of CF_1 to F_o in the thylakoid membrane is facilitated by the δ subunit. Nelson and Karny (1976) have shown that the δ subunit increased the coupling capacity of a partially δ depleted CF_1 . Partially purified δ subunit increased the coupling of a completely δ resolved CF_1 (Younis *et al.*, 1977). *Chromatium* chromatophores completely resolved from F_1 could not regain photophosphorylation by addition of purified F_1 deficient in the δ subunit (Gepshtein *et al.*, 1978).

The regulatory function of the ϵ subunit of CF_1 was suggested when it was shown that the addition of the purified polypeptide caused inhibition of ATPase activity in heat activated CF_1 (Nelson *et al.*, 1972). This

subunit is sensitive to tryptic digestion, which also activates ATPase in isolated CF₁ (Vambutas and Racker, 1965). Prolonged tryptic treatment of CF₁ exposes ATPase activity and digests the ϵ subunits (Deters *et al.*, 1975). However, the ATPase activity of CF₁ may be activated by proteases under conditions under which the ϵ subunit is not digested (Moroney and McCarty, 1981). The fact that anti- γ serum prevented inhibition of heat activated CF₁ by the ϵ subunit indicates the possible interaction between the two subunits (Nelson *et al.*, 1973).

B. Hydrophobic Components

In the late 1960s, a search for components of thylakoid membranes, other than CF₁, that might be required for photophosphorylation was initiated. A number of approaches were used. For example, Livne and Racker (1969) attempted to exploit the fact that the ATPase of bound CF₁ is cold stable, whereas that of soluble CF₁ is cold labile as an assay for the interaction of soluble CF₁ with thylakoid membrane fractions. Since lipids and RNA protected CF₁ from cold inactivation, this assay was too nonspecific to be of much use in identifying potential components of the ATPase complex. Bennun and Racker (1969) extracted thylakoids with acetone and obtained two fractions which were required for the binding of CF₁. This observation has not been followed up.

The breakthrough in this area of research came in 1971 when Kagawa and Racker reported the reconstitution of ³²P_i-ATP exchange from partially purified detergent extracts of mitochondria and phospholipids. The finding that membrane enzymes could be incorporated into lipid vesicles in active form thus allowed the purification of the entire ATPase complex. Carmeli and Racker (1973) extracted thylakoids with cholate in the presence of (NH₄)₂SO₄ and obtained a fraction which contained CF₁ in addition to many other proteins and lipids. After dialysis to remove the cholate and (NH₄)₂SO₄, vesicles formed spontaneously, which catalyzed uncoupler-sensitive ³²P_i-ATP exchange. Further purification of this ATPase complex was achieved by Winget *et al.* (1977), but much better preparations were later made by Nelson and Hauska (1979) and Pick and Racker (1979). The latter workers used 0.5% cholate plus 30 mM octylglucoside, rather than 2% cholate alone, to extract the complex and obtained a more active preparation at a higher yield. After fractionation of this extract with (NH₄)₂SO₄, the active fraction was subjected to sucrose density gradient centrifugation in the presence of phospholipid and a detergent. The use of sucrose gradients to purify the complex was suggested by N. Nelson, who has obtained preparations of similar purity.

An ATPase complex has also been extracted and purified from the chromatophores of *Rs. rubrum* (Bengis-Garber and Gromet-Elhanan, 1979). Extraction was achieved through the use of Triton X-100 in the presence of 20% glycerol, which was required to stabilize the ATPase activity of the preparation. Purification was obtained by chromatography on DEAE-cellulose and glycerol density-gradient centrifugation.

Pick and Racker (1979) detected seven subunits in their preparations of the chloroplast ATPase complex, after electrophoresis in the presence of sodium dodecylsulfate (SDS) by the Weber-Osborn procedure. Five of these components are CF_1 subunits, whereas the components that migrated to positions consistent with apparent molecular masses of about 15–8 kD were considered to be F_0 subunits. The pattern found by Nelson and Hauska (1979) was similar except that an additional band with a mobility consistent with a molecular mass of about 11 kD was detected. Nelson *et al.* (1980) also detected eight components in the ATPase complex from spinach chloroplasts after electrophoresis on gels containing an exponential 12.5–17.5% gradient of acrylamide and SDS.

When the ATPase complex of Pick and Racker (1979) was subjected to two-dimensional electrophoresis (8% acrylamide with 8 M urea in the first dimension and 12.5% acrylamide with SDS in the second), two other components were revealed. One of these peptides comigrates with the δ subunit of CF_1 , and the other migrates with the ϵ -subunit upon electrophoresis in the presence of SDS. Although there is clear evidence that the smallest peptide is a bona fide member of the ATPase complex, the other non- CF_1 peptides detected so far could be contaminants. The peptides detected by Pick and Racker (1979), which migrate close to the δ and ϵ subunits of CF_1 , may arise by limited proteolysis of the CF_1 subunits. Moreover, there is a possibility that new components of the complex will be found. Not all proteins stain well with Coomassie blue dye, and different techniques to visualize peptides on the gels may allow the detection of other peptides in the preparation. Despite these reservations, it is evident that good progress has been made in the purification of the chloroplast ATPase complex.

The best preparation of the *Rs. rubrum*-ATPase complex (Bengis-Garber and Gromet-Elhanan, 1979) contains eight subunits as revealed by SDS gel electrophoresis. The three largest components are likely to be the α , β , and γ subunits of RrF_1 . The remainder of the polypeptides, which range in apparent molecular mass from about 9 kD to 17 kD, have not yet been identified.

The smallest component of F_0 is also the best characterized with respect to its structure and function. This subunit of the ATPase complex has the remarkable property of being soluble in organic solvents (Nelson

et al., 1977) and thus is often called the *proteolipid subunit*. It is extracted from thylakoids by butanol extraction and renders liposomes proton permeable (Nelson *et al.*, 1978). This protein also binds *N,N'*-dicyclohexylcarbodiimide (DCCD). The extraction of CF_1 from thylakoids uncouples photophosphorylation and increases the proton permeability of the membrane (McCarty and Racker, 1966). Low proton permeability is restored by DCCD, which is also an inhibitor of photophosphorylation (McCarty and Racker, 1967). Nelson *et al.* (1978) prepared liposomes that contained the light-dependent bacteriorhodopsin proton pump and the proteolipid. A fraction of these liposomes obtained from a ficoll gradient failed to carry out light-dependent proton uptake unless DCCD was present. These results suggest that the proteolipid acts as the DCCD-sensitive proton channel (or ionophore) of thylakoid membranes. Its physiological function is to conduct protons across the thylakoid membrane to CF_1 .

There is good evidence for a polymeric structure of the proteolipid in the ATPase complex. On the basis of a minimal molecular mass of 7.7 kD, calculated from its amino acid content, Sigrist-Nelson *et al.* (1978) estimated that there are about six proteolipids per ATPase complex. Moreover, complete inhibition of the ATPase activity of thylakoids occurs when only one proteolipid out of six is reacted with DCCD (Sigrist-Nelson *et al.*, 1978). A spin-label analog of DCCD, *N*-(2,2,6,6-tetramethylpiperidyl-l-oxyl)-*N'*-cyclohexylcarbodiimide, was shown (Sigrist-Nelson and Azzi, 1979) to interact with the ATPase complex in thylakoids in a manner similar to that of DCCD. The ESR spectrum of this probe (NCCD) bound to the proteolipid in thylakoids was that of a highly immobilized species. In contrast, the mobility of spin label bound to the extracted proteolipid was much less restricted. Evidence for spin-spin interaction of the NCCD-labeled proteolipid in thylakoids reacted with high concentrations of NCCD was obtained. This finding suggests that at least some of the proteolipid molecules are closer than 150–200 nm of each other. The spin label bound to the proteolipid in thylakoids was only very slowly reduced by ascorbate, even after removal of CF_1 , suggesting that the proteolipid is not accessible to the medium.

The molecular weight of the ATPase complex, purified by Pick and Racker, was determined by low angle X-ray scattering to be 435,000 (H. Paradies, cited by Pick and Racker, 1979). Given a molecular weight of CF_1 of 325,000 (Farron, 1970; Paradies *et al.*, 1978) and six copies of the proteolipid per ATPase complex, about 85% of the complex would consist of these two proteins. Thus, the remaining proteins of this preparation should contribute about 62 kD to the molecular value of the complex. This is more than enough to accommodate one copy of each of the

three polypeptides in the range of 13–18 kD that Pick and Racker claim to be a part of the complex. Multiple copies of one or more of these subunits could also exist, although some lipid and detergent is likely to be bound to the complex.

Although the number of proteins in F_o remains uncertain, it is evident that at least one peptide other than the DCCD binding proteolipid must be present. CF_1 does not bind to vesicles containing the purified proteolipid. Thus, one or more of the F_o components is likely to be necessary for CF_1 binding. Nelson *et al.* (1980) suggested that one of the subunits of F_o may be required for the assembly of the proteolipid into a functional proton ionophore. This speculation is based on considerations of the assembly of the ATPase complex. Although the proteolipid is synthesized inside chloroplasts, one polypeptide that purifies with F_o (apparent molecular mass about 11 kD) is of cytoplasmic origin (Nelson *et al.*, 1980). Partially completed CF_1 – F_o in the membrane would uncouple since it should promote proton permeability through the proteolipid. If, however, the 11 kD polypeptide were required for the assembly of the proteolipid into an active proton channel, and if the attachment of CF_1 were to take place, the wasteful leakage of protons through the proteolipid channel would be prevented. It is interesting to note that the study of the biosynthesis of the ATPase complex can give insights into functions of its components.

C. Reconstitution

Photophosphorylation has been reconstituted with two different kinds of preparations. The earlier investigations dealt with the ability of F_1 (or polypeptides derived from these molecules) to stimulate photophosphorylation in F_1 -deficient membranes. The emphasis has now shifted towards reconstitution of either $^{32}P_i$ –ATP exchange or photophosphorylation using either native or exogenous proton pumps to generate the electrochemical proton gradient, the entire ATPase complex and phospholipids.

The removal of CF_1 from thylakoid membranes by extraction with dilute solutions of EDTA at low ionic strength is incomplete and results in a pronounced increase in the proton permeability of the membrane (McCarty and Racker, 1966). The rebinding of CF_1 to the depleted membranes could, then, stimulate photophosphorylation in two ways. First, the added CF_1 could merely block the proton leak through F_o and allow the buildup of a larger ΔpH . The endogenous CF_1 could then carry out the actual catalysis of ATP production. Second, the added CF_1 could be catalytically active. CF_1 restores proton uptake to CF_1 -deficient

thylakoids (McCarty and Racker, 1966), as does DCCD, which blocks the proton channel. At low concentrations, DCCD even restores some phosphorylation to EDTA-treated thylakoids (McCarty and Racker, 1967). The exposure of CF_1 in the cold to high salt concentrations at mildly acid pH values induces a rapid inactivation of its ATPase activity (McCarty and Racker, 1966). There is some dissociation of the enzyme during this treatment. Remarkably, fractions of cold-treated CF_1 that eluted from a Sephadex G-200 column with an average apparent molecular mass of roughly 40 kD retained some ability to stimulate photophosphorylation in CF_1 -deficient particles, although these fractions had no ATPase activity (R. E. McCarty, unpublished experiments, 1968). These results suggest that the main activity of CF_1 in the reconstitution of phosphorylation is to block the F_0 proton channel. This conclusion is supported by experiments with tentoxin, which inhibits the ATPase activity of CF_1 from some species, but not others (Selman and Durbin, 1978).

To show unambiguously that added CF_1 can function catalytically in photophosphorylation, thylakoid membranes completely stripped of CF_1 were required. Although this may be achieved either by EDTA extraction of thylakoids followed by density gradient centrifugation (Moudrianakis, 1968) or by incubation of vesicular preparations of thylakoids with silicotungstic acid (Lien and Racker, 1971b), these CF_1 -deficient particles catalyze very poor rates of photophosphorylation even in the presence of CF_1 . By extraction of lettuce chloroplast thylakoids with 2 M NaBr and 5 mM dithiothreitol, thylakoid preparations from which more than 90% of the CF_1 had been removed were obtained (Nelson and Eytan, 1979). The depleted membranes catalyzed very low rates of *N*-methylphenazonium methosulfate (PMS)-dependent cyclic phosphorylation. After reconstitution with CF_1 , however, rates of phosphorylation, as high as one-half of those of control thylakoids, were obtained, suggesting that the added CF_1 must function catalytically. Reconstitution studies have also been helpful in the search for roles of F_1 subunits in photophosphorylation as pointed out in Section III,A,2.

The approach of resolution of single components of the complex to elucidate their function suffers from some limitations. First, it may be difficult to isolate the components in active form. Second, in multicomponent systems the assay for an individual component may be tedious and tricky. Unless saturating amounts of all other components are present, erroneous conclusions about the activity of the membrane fractions may be reached (Racker, 1979). The ability to reconstitute energy-linked activities (Kagawa and Racker, 1971) led to a new approach to resolution and reconstitution analysis of oxidative and photosynthetic phos-

phorylation. This approach has been very successfully applied to the isolation in active form of the ATPase complex from a number of different kinds of coupling membranes as well as to that of many other membrane proteins.

The first reconstitution of an energy-dependent reaction related to photophosphorylation was accomplished by Carmeli and Racker (1973). A cholate extract from thylakoids treated with dithiothreitol in the dark to activate $^{32}\text{P}_i$ -ATP exchange showed little exchange activity. After extensive dialysis to remove the cholate, $^{32}\text{P}_i$ -ATP exchange was detected. This exchange activity, which was sensitive to uncouplers and phosphorylation inhibitors, appeared to be associated with the formation of vesicular structures, as revealed by the electron microscope.

The cholate extracts of thylakoids contain acyl lipids of the thylakoids, but are deficient in chlorophyll and other pigments. Ammonium sulfate fractionation removes much of the thylakoid lipid (Winget *et al.*, 1977). A lipid requirement for reconstitution of $^{32}\text{P}_i$ -ATP exchange activity was evident using the preparation fractionated with $(\text{NH}_4)_2\text{SO}_4$. Crude soybean lipids were most effective, whereas much lower activity was observed in the presence of either phosphatidylethanolamine or phosphatidylcholine alone. Mixtures of these two phospholipids were more effective, as is the case for the reconstitution of activities catalyzed by the mitochondrial ATPase. Winget *et al.* (1977) used a cholate dilution procedure to effect reconstitution, rather than dialysis. Thylakoid membranes contain essentially no phosphatidylethanolamine and only a small quantity of phosphatidylcholine. The major acyl lipids are galactosyldiglycerides and sulfoquinovosyldiglycerides. Although some of the thylakoid lipids were still present in the complex fractionated with $(\text{NH}_4)_2\text{SO}_4$ (Winget *et al.*, 1977), it is apparent that galacto- and sulfolipids are not required in large amounts for the activity of the thylakoid ATPase complex. It is possible, however, that the complex would be more active in the presence of thylakoid lipids. Liposomes containing the ATPase complex from *Rs. rubrum* have been also prepared which catalyze $^{32}\text{P}_i$ -ATP exchange (Bengis-Garber and Gromet-Elhanan, 1979).

$^{32}\text{P}_i$ -ATP exchange is a convenient assay for energy conservation by reconstituted ATPase complexes. This exchange can, however, be catalyzed by enzymes that contaminate the preparation. For example, polynucleotide phosphorylase catalyzes an $\text{ADP}-\text{P}_i$ exchange. The β -phosphate of ADP could then be transferred to another ADP molecule by adenylate kinase to form ATP labeled in the γ phosphate. This pathway apparently explains the uncoupler-insensitive $^{32}\text{P}_i$ -ATP exchange catalyzed by less pure preparations of the ATPase complex from *Rs. rubrum*

(Z. Gromet-Elhanan, personal communication). Where possible, it is preferable to assay net ATP synthesis in reconstituted systems. To accomplish this, either a proton pump must be incorporated into the liposome membranes together with the ATPase complex or artificial proton gradients must be generated. Winget *et al.* (1977) prepared liposomes containing bacteriorhodopsin, the light-driven proton pump from *Halobacterium halobium*. These liposomes were previously shown (Racker and Stoeckenius, 1974) to accumulate protons in the light. The thylakoid ATPase complex was incorporated into the liposomes by prolonged sonication. These liposomes catalyzed light-dependent ATP synthesis, which was strongly inhibited by uncouplers and phosphorylation inhibitors. A similar light-dependent ATP synthesis is catalyzed by liposomes containing the *Rs. rubrum* ATPase complex and bacteriorhodopsin (Z. Gromet-Elhanan, personal communication).

Nelson and Hauska (1979) have accomplished a reconstitution of photophosphorylation using chloroplast components. A PSI reaction center (RC) preparation, which is active in NADP⁺ photoreduction and which contains six polypeptides, was isolated by Bengis and Nelson (1977). (See also Okamura *et al.*, chapter 5, this volume.) Incorporation of the RC into phospholipid liposomes was achieved by sonication. These liposomes catalyzed a light-dependent acidification of the medium when illuminated under anaerobic conditions in the presence of PMS a mediator of cyclic electron flow around PSI. Although this result suggests that the liposomes catalyze light-dependent proton efflux, evidence for proton influx was also obtained. The RC is thus likely to be incorporated into the membrane in two orientations. The predominant arrangement is opposite to that of the RC in chloroplasts. That is, the oxidizing side of the complex is accessible from the outside. This orientation would result in proton liberation into the medium upon illumination of the vesicles in the presence of PMS. The proton gradient thus created is in the wrong direction to be used by CF₁ in its normal orientation for ATP synthesis. Some of the liposomes, however, probably contain the RC in the correct (oxidizing side inward) orientation and catalyze proton uptake. In agreement with this idea, addition of the ATPase complex from thylakoids to the RC containing liposomes resulted in a reconstitution of PMS-dependent photophosphorylation which was inhibited by uncouplers and energy transfer inhibitors (Nelson and Hauska, 1979).

Although the demonstration that the solubilized ATPase complex can be incorporated in active form into liposomes is an important development, it is apparent that improvements in the methodology will be required before this procedure realizes its full potential. The rates of ATP

synthesis in reconstituted membranes are very low compared to those of thylakoid membranes. For example, the rate of ATP synthesis by vesicles containing the ATPase complex and the PSI RC can be calculated to be about 10 nmole/min/nmole CF_1 , based on a molecular weight of the ATPase complex of 435 kD and the assumption that all of the complex added is incorporated into vesicles of the proper orientation. A similar rate of photophosphorylation for the bacteriorhodopsin-ATPase complex (Winget *et al.*, 1977) was obtained. In contrast, thylakoids catalyze PMS-dependent photophosphorylation at rates as high as 1200 μ mole/hour/mg Chl. Assuming there are 1.3 nmole of CF_1 per milligram of Chl in thylakoids (Strotmann *et al.*, 1973), this rate corresponds to about 15,000 nmole/min/nmole CF_1 .

IV. ATPase Activity of the Coupling Factors

A. Properties

Most of the data indicate that ATPase activity of the coupling factor part of ATPase complexes is a reflection of the reversal of the terminal steps of phosphorylation. Therefore, the study of this partial reaction gives valuable information that can be used to reach an understanding of the mechanism of ATP synthesis. Although the purified enzyme does not catalyze phosphorylation of medium ADP, high rates of ATP hydrolysis can be measured. The presence of this activity in the isolated enzyme makes it possible to analyze the reaction in the purified protein, free of possible interference from the membrane-bound multienzyme systems. Analysis of the kinetics, substrate specificity, activation by ions, binding of ions and substrates, inhibitors, and chemical modifications are some of the areas of research that gave considerable insight into the mode of action of the enzyme.

Divalent cations are activators of a wide variety of enzymes in which nucleotides serve as substrates. This is also true for phosphorylation and ATPase activities in photosynthetic membranes. An anomaly in the expected saturation curve for the dependence of the rate of ATPase on the concentration of divalent cations and of ATP in *Chromatium* chromatophores raised the possibility that the divalent nucleotide complex is the true substrate for this activity (Gepshtein *et al.*, 1975). Indeed, a normal saturation curve was observed for the rate of ATPase activity as a function of divalent ATP-complex as substrate. However, both the free divalent cation and the free ATP were found to be competitive inhibitors of soluble ATPase from *Chromatium* and from chloroplasts (Hochman *et al.*, 1976; Gepshtein and Carmeli, 1977;). Based on these observations, a

model for substrate binding during catalysis was suggested in which the substrate, a divalent cation-ATP complex, is bound to two points in the active site. At one of the points, divalent cation and at the other, the base in the nucleotide, is (probably) bound. The binding of the complex to the first site is competitively inhibited by excess of free cations and of the other site by free ATP. Differences in the inhibition constant for various free divalent cations cause in some cases a great discrepancy between the apparent and the calculated effectiveness of these ions as activators of ATPase. Because the K_i for the free ions was $Mn^{2+} < Mg^{2+} < Ca^{2+}$ the apparent order of effectiveness was $Mn^{2+} < Mg^{2+} < Ca^{2+}$, although the calculated effectiveness was $Mn^{2+} > Mg^{2+} > Ca^{2+}$ in CF_1 (Hochman *et al.*, 1976). These results indicated that both the isolated and the membrane-bound CF_1 are better activated by Mg^{2+} rather than Ca^{2+} ions. However, since free Mg^{2+} is a much stronger inhibitor than Ca^{2+} in soluble CF_1 the purified protein appears to catalyze a Ca^{2+} -dependent ATPase.

The response to divalent cations seems to be highly sensitive to changes in the state of the enzyme. In chromatophores, ATPase can be activated by both Ca^{2+} and Mg^{2+} ions, whereas the divalent cation-nucleotide complex seems to be the true substrate (Johannson *et al.*, 1973; Gepshtein *et al.*, 1975; Edwards and Jackson, 1976). Although trypsin activation decreased K_i for competitive inhibition by Mg^{2+} in *Chromatium* (Gepshtein *et al.*, 1975), a transmembrane $\Delta\bar{\mu}_{H^+}$ induced an increase in the K_i for Mg^{2+} as a noncompetitive inhibitor in *Rs. rubrum* chromatophores (Edwards and Jackson, 1976). The noncompetitive nature of inhibition indicates that divalent cations can regulate activity by binding to a site that is different from the active site in *Rs. rubrum* chromatophores. Yet in isolated F_o-F_1 from *Rs. rubrum*, free Mg^{2+} was a competitive inhibitor. It is interesting to note that a major conformational change that occurs on solubilization of the coupling factor or on trypsin treatment results in most cases in an apparent Ca^{2+} -dependent ATPase activity. As indicated earlier, a decrease in the K_i for free Mg^{2+} , whereas an increase in K_i for free Ca^{2+} ions, is responsible for these changes in CF_1 and in F_1 from *Chromatium* chromatophores. It is possible that similar changes result in the apparent Ca^{2+} -dependent ATPase activity in F_1 isolated from *Rs. rubrum* (Johannson *et al.*, 1973; Lucke and Klemme, 1976), *Spirulina platensis* (Owers-Narhi *et al.*, 1979), and from *Mastigocladus laminosus* (Binder and Bachofen, 1979). Exposure of the site of ion binding at the catalytic site during this conformational change that allows selective approach of free Mg^{2+} rather than Ca^{2+} ions in the presence of the divalent metal-nucleotide complex could result in this phenomenon.

Slight modification of the conformation during the solubilization of the CF_1-F_0 (Carmeli and Racker, 1973) and of F_0-F_1 from *Rs. rubrum* chromatophores (Oren and Gromet-Elhanan, 1979) results in an intermediate response to divalent ions. Both Ca^{2+} and Mg^{2+} can support ATPase activity, whereas Mg^{2+} becomes more inhibitory than in the membrane-bound enzyme, but less than in the soluble coupling factor.

Solubilization of the coupling factor also results in up to a 10-fold increase in the apparent K_m for ATPase activity. An increase in the K_m was observed on solubilization of CF_1 (Hochman *et al.*, 1976) and in F_1 from *Rs. rubrum* (Johannson *et al.*, 1973; Lucke and Klemme, 1976; Webster and Jackson, 1978). However, a 10-fold decrease in K_m was observed in isolated F_1 from *Chromatium* chromatophores (Gepshtein and Carmeli, 1977). The rather high concentration of Ca^{2+} ions (80 mM) required for maximal activation of the trypsin-activated soluble F_1 from *Spirulina* (L. Owers-Narhi and C. F. Yocum, personal communication) probably also reflects an extreme case of increase in the K_m for the divalent metal-nucleotide complex as substrate.

The presence of divalent metal ions in the substrate complex and their low K_i as competitive inhibitors make them good probes of the active site in ATPase. One of the ways to probe an enzyme involves a correlation between binding and kinetic parameters. Since it gives the highest measured effectiveness when used as ATP complex and since its paramagnetic properties can be used for detection by ESR, Mn^{2+} was employed for this type of study. CF_1 has one tight and five loose sites for Mn^{2+} binding (Table II). Any di- or triphosphonucleosides or pyro-

TABLE II
Binding of Mn^{2+} to Purified CF_1^a

Additions	K_d (μM)	n	K_d (μM)	n
None	3.80	1	188	5
ATP, 2 Eq	0.98	2	50	4
ADP, 2 Eq	0.83	2	100	4
GDP, 2 Eq	1.20	2	200	4
CDP, 2 Eq	2.00	2	200	4
Pyrophosphate, 2 Eq	2.50	2	100	4
ATP, 2 Eq, 40 mM bicarbonate	0.07	2	30	4

^a Mn^{2+} was titrated to 40 μM CF_1 in 40 mM *N*-2-hydroxymethylpiperazine-*N'*-ethanesulfonic acid (pH 8) and the amount of bound ions calculated from the ESR spectra of the free Mn^{2+} . The number of sites (n) and their dissociation constants (K_d) were calculated from Scatchard plots of statistically treated data. Additions were made in equivalent (Eq) quantities to the amount of CF_1 (Hochman and Carmeli, 1981).

phosphate induce a second tight site. Also, only two moles of nucleotides per mole CF_1 were required for this effect. A possibility that the two tight binding sites are the active sites is suggested by the similarity between the K_i for Mn^{2+} as competitive inhibitors and the K_d for its binding. There is also a resemblance in the rather wide specificity for triphosphonucleosides as substrates (Farron, 1970), the diphosphonucleosides as competitive inhibitors (Hochman and Carmeli, 1981) and the specificity of nucleotides in their effect on decreasing the K_d for Mn^{2+} binding. Although allosteric effectors could induce changes that might vary the K_d for binding at other sites on the enzyme, the changes in the binding of substrate to the active site should agree with the changes in the kinetic parameters. Indeed, effectors such as bicarbonate, which decrease the K_m (Hochman and Carmeli, 1981) correspondingly decrease the K_d for Mn^{2+} binding to CF_1 . (For bicarbonate effects on other reactions in photosynthesis, see Govindjee, 1982.)

The possible function of the divalent metal nucleotide complex as substrate is also indicated from studies of analogs. Thus the inert complexes of Co(III)-phenanthroline with ADP or ATP competitively inhibit ATPase activity in CF_1 (Hochman *et al.*, 1979). Two sites of binding per mole of CF_1 were found with K_d slightly lower than the K_i for inhibition. That these sites might also be the sites of binding of divalent metal ions was indicated by the observed release of bound Mn^{2+} on interaction of CF_1 with the Co(III) complexes.

The binding of divalent metal-nucleotide complex to CF_1 causes a significant change in the enzyme probably through cooperative interactions. These changes which are expressed in resistance to cold inactivation can be induced by various di-, triphosphonucleosides, and pyrophosphate in the presence of various divalent metal ions (Posorske and Jagendorf, 1976). An exception is ATP, which does not require addition of divalent metal-ions and therefore might act through binding to a different site on the enzyme. The membrane-bound enzyme has a higher degree of specificity for Mg^{2+} and ATP, which protect it from the rather harsh treatment by 0.75 M NaBr (Nelson and Broza, 1976). Some other divalent metal ions were less effective, whereas nucleotides other than ATP and GTP protect.

Chemical modification of specific amino acid residues on the protein is another powerful approach to the understanding of the mode of action of an enzyme. Although the full benefit of such studies requires knowledge of the amino acid sequence and the tridimensional structure of the enzyme, an analysis of the effect of specific modification on the binding and regulation process yields valuable information on the involvement of residues in these processes. The role of ϵ -amino groups, of

lysyl residues, in binding of ATP to the active site was deduced from the finding that reaction of chloroplasts with trinitrobenzenesulfonate caused a 10-fold increase in the K_m but no change in the maximal velocity of ATPase activity in CF_1 (Oliver and Jagendorf, 1976). This relatively selective modification could be achieved under energized conditions and after amidation in the dark of the chloroplast-bound CF_1 . It was difficult to assess which lysyl residue is responsible for the effect since three residues on the γ subunit and one on each of the α and β subunits were modified. The fact that only 50% protection was achieved by phosphate at concentrations that saturate phosphorylation, whereas ADP and ATP at lower concentrations in which they act as allosteric effectors gave additional 50% protection indicates that the modification might be a result of change in binding of substrate. The change in binding was caused partially because of direct modification and partially because of changes in conformation.

Chemical modification by pyridoxal phosphate seems to indicate the involvement of ϵ -amino group of lysyl residues in catalysis rather than in binding alone. Modification of illuminated chloroplasts with this reagent caused a change in the maximal velocity without alteration of the K_m for phosphorylation (Sugiyama and Mukohata, 1978). As was the case for modification with trinitrobenzenesulfonate, multiple binding of pyridoxal phosphate occurs. However, kinetic data indicate that the major inhibitory effect is caused by the binding of one modifier per mole of enzyme to a high affinity binding site (Sugiyama and Mukohata, 1979a). This site is suggested to be at the active site of the enzyme since the binding of pyridoxal phosphate is also competitively inhibited by ATP with K_i close to the K_m for ATP hydrolysis in the isolated CF_1 . If the active site is located on the β subunit, it is likely that there are at least two active sites per mole of enzyme each at one of these subunits. The fact that modification of one lysyl residue results in complete inhibition of activity could indicate interaction between these subunits. Modification of one tyrosyl residue on the β subunit (Deters *et al.*, 1975), which causes complete inhibition of ATPase activity, was accompanied by considerable changes in conformation of the protein (Holowka and Hammes, 1977). Similar changes might occur in the lysyl-modified CF_1 .

Treatments of chloroplasts with the arginyl-modifying reagents phenylglyoxal and butadione caused inhibition of phosphorylation and ATPase activity (Schmid *et al.*, 1977). From kinetic studies, it was suggested that modification of one arginine residue per CF_1 caused the inhibition (Andreo and Vallejos, 1977). Since the inhibition of the activity was prevented in the presence of substrate amounts of ATP or GTP, it was suggested that this residue is essential for the catalysis.

The highly reactive thiol group has an important role in the function of CF_1 . Soluble CF_1 has either 12 (Farron and Racker, 1970) or 14 thiol groups (Binder *et al.*, 1978). Although two SH groups are alkylated in the dark when chloroplasts are incubated with *N*-ethylmaleimide, only the alkylation of a third group on the γ subunit in the presence of a proton gradient causes partial inhibition of phosphorylation and ATPase activity (McCarty *et al.*, 1972; McCarty and Fagan, 1973; Magnusson and McCarty, 1975). Inhibition could be a result of a change in the function of the γ subunit in proton transport and/or of an interference in the conversion of the enzyme to an active form. The bifunctional reagent *o*-phenylenebismaleimide, which linked two SH groups on the γ subunits, uncoupled by increasing the membrane permeability to protons (Weiss and McCarty, 1977). Heat treatment of CF_1 in the presence of the oxidizing reagent *o*-iodosobenzoate also caused partial inhibition of ATPase activity and the loss of the allosteric effect of ADP (Vallejos *et al.*, 1977). This treatment caused the disappearance of four SH groups, a couple on each of the β and γ subunits, probably as a result of a formation of two S—S bridges (Andreo *et al.*, 1979). Similar modifications occur in membrane-bound CF_1 in the presence of light-induced $\Delta\bar{\mu}_{H^+}$. It is possible that modification of the same SH group on the γ subunit causes an inhibition of activity since a sequential treatment of chloroplasts in the light by the alkylating and the oxidizing reagent did not result in an additive inhibition. A model for the inhibition of phosphorylation in chloroplasts by SH reagents has been proposed by Moroney *et al.* (1980).

Partial inhibition of activity also resulted from treatment of chloroplasts in the light with sulfate (Ryrie and Jagendorf, 1971), and mercuric ions (Izawa and Good, 1969). Involvement of the carboxyl group in the catalysis are indicated from the finding of complete inhibition of ATPase activity in F_1 isolated from *Chromatium* (Gepshtein *et al.*, 1978) and in CF_1 (Shoshan and Selman, 1980) by dicyclocarbodiimide and by Woodward's reagent K (Arana and Vallejos, 1980). The fact that the inactivation by Woodward's reagent K was prevented by ATP might indicate that the modified carboxyl is involved in nucleotide binding; the protection against modification by dicyclocarbodiimide afforded by Ca^{2+} (Arana and Vallejos, 1980) might indicate that the carboxyl modified by this reagent is involved in binding of metal ions.

B. Regulation in Vitro and in Situ

Several levels of regulation can be distinguished in the membrane-bound, multiple subunit ATPase complexes. There is a direct ther-

modynamic control exerted on ATP hydrolysis by the proton gradient formed either during ATPase activity or as a result of light-induced proton uptake across the thylakoid or chromatophore membrane. Proton gradients also indirectly regulate enzyme activity by inducing conformational changes which alter the reactivity of the enzyme. These changes may affect the position of the ϵ subunits which may be inhibitors and can also be brought about by various treatments of the isolated enzyme. Both the isolated and the membrane-bound protein are regulated by small molecules either by competitive or by allosteric and cooperative interactions. Thus, ADP is both an allosteric effector and a competitive inhibitor, carboxylic acids are allosteric effectors, whereas divalent metal ions are activators and competitive inhibitors.

The membrane-bound ATPase is found in various states of activation. Active ATP hydrolysis is catalyzed by the photosynthetic bacteria such as *Rs. rubrum*, *Rp. capsulata*, and *Rp. spheroides*, but very little activity can be detected in chloroplast thylakoids from higher plants, membranes from the cyanobacteria *Anabaena variabilis*, *Spirillum plantensis*, and from the photosynthetic bacterium *Chromatium vinosum*. In most of these membranes a transmembrane proton gradient indirectly controls by modulating ATPase activity. In isolated thylakoids in the presence of a SH compound, either light-induced (Petrack *et al.*, 1965) or artificially induced (Kaplan *et al.*, 1967) $\Delta\bar{\mu}_{\text{H}^+}$ unmasked ATPase activity. Added SH compounds are not required for the light-induced activation of ATPase in intact chloroplasts (Kraayenhof *et al.*, 1969; Inoue *et al.*, 1978; Mills and Hind, 1979). Thioredoxin present in the stroma may be the reactive SH compound since its addition to thylakoids induces activation in the light (Mills *et al.*, 1980). The activation involves probably a reduction of a disulfide bond and conformational changes. This is apparent from the finding that although the active state decays in the absence of ATP in the dark (Petrack *et al.*, 1965), CF₁ released at this state from the thylakoid membrane catalyzes ATPase activity (McCarty and Racker, 1968). The maintenance of the activated state requires the proton gradient since it is maintained by light and dissipated by uncouplers (Carmeli, 1969). The level of activity is also correlated to the size of the ΔpH formed during ATP hydrolysis in the dark (Bakker-Grunwald, 1977).

There is a close correlation between the activation state of ATPase and the binding of ADP to CF₁. It seems that the light-induced conformational changes required for activation of ATPase also cause the release of bound ADP (Harris and Slater, 1975). The kinetics of the light-induced release of bound ADP (Strotmann and Bickel-Sandkötter, 1977) is similar to the kinetics of light activation of ATPase, whereas the kinetics of the rebinding of ADP in the dark to thylakoids depleted of

nucleotides by preillumination (Strotmann and Bickel-Sandkötter, 1977; Shoshan and Selman, 1979) is similar to the kinetics of the ADP-induced acceleration of the decay of the light-triggered state of ATPase (Carmeli and Lifshitz, 1972). Similar to the features of tightly bound nucleotides, this effect was specific for ADP at low concentrations (K_{app} about $1 \mu M$), but it was competitively inhibited by ATP with a $K_i = 4 \mu M$, a concentration much lower than the K_m of ATP for catalysis. Phosphate stabilizes the activated state in a noncompetitive manner with respect to ADP. Although these data show that the release of ADP is correlated to induction, whereas the binding of ADP has the opposite effect, the depletion of ADP does not activate unless CF_1 is also treated with SH compounds. It is interesting to note that tentoxin, which stimulates ATPase activity (Reimer and Selman, 1979), also causes the dissociation of ADP. The faster decay of the light-triggered state in intact chloroplasts (Inoue *et al.*, 1978) than in chloroplasts, which were osmotically shocked after triggering (Mills and Hind, 1979), is probably due to the fact that in intact organelles ADP induces fast decay of the activation of ATPase, while it is being diluted during the osmotic shock.

ATPase activity in chromatophores is also regulated by transmembrane proton gradients. In chromatophores from *Rp. capsulata* (Baccarini-Melandri *et al.*, 1975) and *Rs. rubrum* (Edwards and Jackson, 1976), which catalyze considerable ATP hydrolysis in the dark, high concentrations of uncouplers dissipate the ATP-induced proton gradient and inhibit the activity. In both cases, the inhibition is overcome by illumination. However, in *Rp. capsulata* chromatophores, steady state illumination also stimulated ATPase activity. Thus, although energization causes stimulation of ATPase activity, the cause of the stimulation varies in different systems. In *Rs. rubrum* chromatophores, energization causes a decrease in the inhibition of ATPase by free Mg^{2+} under steady state conditions (Edwards and Jackson, 1976). The stimulation was a result of a change in the maximal velocity in *Rp. capsulata*, but a flash-induced decrease in K_m resulted in a short-lived increase in the rate of ATPase activity in *Rs. rubrum* chromatophores (Baltscheffsky and Lundin, 1979). ADP inhibited the light-induced changes in chromatophores from both bacteria. In analogy to chloroplasts, it was suggested that the inhibition by ADP was caused by destabilization of the more active form of the ATPase. Phosphate, which stabilizes the light-triggered state in chloroplasts (Carmeli and Lifshitz, 1972), stimulated ATPase activity in *Rp. capsulata* (Baccarini-Melandri *et al.*, 1975) and *Rs. rubrum* (Baltscheffsky and Lundin, 1979) chromatophores.

Isolated CF_1 also undergoes conformational changes during heat treatment (Farron and Racker, 1970) and a reduction of a S—S bond by

the SH compound (dithiothreitol) present during the activation of ATPase. Heating in the absence of dithiothreitol causes a S—S exchange (Ravizzini *et al.*, 1980). It is reasonable to suggest heat treatment causes also a displacement of the ϵ -subunit. This suggestion is supported by the finding that this subunit is an ATPase inhibitor (Nelson *et al.*, 1972a). Trypsin treatment stimulates ATPase activity in isolated CF₁ (Vambutas and Racker, 1965), in thylakoids (Lynn and Straub, 1969), in chromatophores, in isolated F₁ from *Chromatium* (Gepshtein and Carmeli, 1977), and in isolated F₁ and membranes from cyanobacteria (Binder and Bachofen, 1979; Owers-Narhi *et al.*, 1979). Since ATPase activity is likely to be the reversal of ATP synthesis, it is tempting to suggest that the ϵ -subunit is an inhibitor of the forward reaction. However, since synthesis cannot take place without the existence of a proton gradient, which also activates the enzyme, it is difficult to distinguish between the two roles of the gradient. It was suggested that the lag observed in the initial rate of photophosphorylation (for details, see Harris, 1978) is due to the time required for the energy-dependent displacement of an inhibitory subunit (Harris and Crofts, 1978). Although no direct evidence was shown, the fact that this lag is shortened in chloroplasts, which were preilluminated in the presence of dithiothreitol, supports this suggestion. However, this interpretation is complicated by the fact that the assay or phosphorylation is done in the presence of ADP, which is a negative effector for the activated CF₁. At least during activation by short light flashes, membrane potentials ($\Delta\psi$) seem to regulate ATP synthesis as suggested earlier by Junge (1970). Similar regulation of ATP synthesis by $\Delta\psi$ is seen in *Rp. capsulata* chromatophores (Melandri *et al.*, 1978) and in ATPase activity in *Rs. rubrum* chromatophores (Baltscheffsky and Lundin, 1979).

Based on these findings, it is tempting to speculate that in chloroplasts *in vivo* ATPase is inactive in the dark and thus cannot hydrolyze the ATP present in the stroma. Activation that is required for synthesis of ATP involves $\Delta\mu_{H^+}$ induced conformational changes in CF₁ possibly accompanied by a displacement of the ϵ -subunits and release of tightly bound ADP. Since thioredoxin is present, a S—S bond(s) is reduced also inducing ATPase activity. However the $\Delta\mu_{H^+}$ prevents hydrolysis of ATP formed during the light. Once the light is turned off, ADP binding probably deactivates the enzyme.

The modulation of the activity of ATPase by the proton gradients made it difficult to observe a direct thermodynamic control of ATPase activity. A dissipation of the gradient, which should release the control on the coupled proton movement, also results in a decrease in the state of activation. However, in chloroplast thylakoids, it was found that the

effect of uncouplers on ATPase activity can be observed as a stimulation of the initial rate, before the triggered state decays or at steady state, when the uncoupler-dissipated proton gradient is partially offset by light-induced proton uptake which maintains the active state (Carmeli, 1969). Stimulation of the initial rates of ATPase activity by uncouplers was also observed in *Rs. rubrum* chromatophores (Baltscheffsky and Lundin, 1979) and at steady state illumination in *Rp. capsulata* chromatophores (Baccarini-Melandri *et al.*, 1975).

The fact that membrane-bound ATPases under illumination *in situ* seem to be activated to catalyze reversible formation of ATP could place a physiological importance on product inhibition. ADP is a potent competitive inhibitor ($K_i = 40 \mu M$) of light-triggered ATPase in chloroplasts (Bennun and Avron, 1965). Therefore, the hydrolysis of ATP would be moderated as long as a sufficient concentration of ADP is present. Once the light is turned off, even lower concentrations of ADP ($K_{app}, 1 \mu M$) promote rapid decay of the activated state (Carmeli and Lifshitz, 1972), probably through an allosteric interaction. An allosteric inhibition by ADP of ATPase activity was also described in isolated CF_1 , with a Hill constant of $n = 1.9$ (Nelson *et al.*, 1972b). The turnover number of the ADP-inactivated state was almost 1000-fold lower than the active state, whereas a dissociation constant of about $1 \mu M$ for ADP was estimated for this effect (Cantley and Hammes, 1975a). In chromatophores from *Rp. capsulata* (Baccarini-Melandri *et al.*, 1975) and from *Rs. rubrum* (Baltscheffsky and Lundin, 1979), activation of ATPase was inhibited by micromolar concentrations of ADP. It seems, therefore, that during ATP synthesis, ADP controls hydrolysis mostly as an allosteric effector. However, it still acts, although somewhat less effectively, as a competitive inhibitor ($K_i = 0.28 mM$) to slow down ATP hydrolysis in the dark. Since considerable hydrolysis is catalyzed without activation in chromatophores, competitive inhibition by ADP has importance in controlling activity *in situ*. In chloroplasts and chromatophores, free Mg^{2+} ions and free ATP act as poor competitive inhibitors with the Mg -ATP complex as substrate. Therefore, their significance in controlling ATPase activity *in situ* is questionable. Yet free Mg^{2+} ions are potent noncompetitive inhibitors of ATPase activity in *Rs. rubrum* chromatophores in the presence of high concentrations of uncoupler (Edwards and Jackson, 1976). Although this finding is mechanistically interesting, more data are required for assessment of its physiological significance.

ATPase activity is regulated by anions. Since anions such as carboxylic acids, phosphate, and bicarbonate are present in photosynthetic organelles, their changing levels could have physiological importance in regulation of the activity. Bicarbonate and maleate stimulate Mg^{2+} -de-

pendent ATPase activity in heat-treated isolated CF_1 (Nelson *et al.*, 1972b). The fact that in the presence of maleate at pH 6 both K_{app} and V_{app} increased suggested that the anions act as allosteric effectors. Analysis of the kinetic parameters show (Hochman and Carmeli, 1982) that also at pH 8, which is the physiological pH, only a decrease in the K_{app} of Mn^{2+} -dependent ATPase activity is caused by these anions. Sulfite modified ATPase activity in both membrane-bound and soluble F_1 from *Rs. rubrum* (Webster *et al.*, 1977). The anion decreased the K_{app} for Ca-ATP in the isolated enzyme and in uncoupled chromatophores and increased the K_i for inhibition by free Mg^{2+} ions thus stimulating ATPase activity.

A possible resemblance to the activation of ATPase in chloroplasts and in chromatophore membranes to that of isolated F_1 in solution is indicated from the findings that trypsin and heat-treated isolated F_1 from chloroplasts and from *Chromatium* chromatophores catalyzes very low presteady state rates of activity (Carmeli *et al.*, 1979). The rate of activity is accelerated in the presence of hydrolyzable substrate such as Ca-ATP with K_m similar to the K_m of catalysis, but not in the presence of the ATP analog adenylylimidodiphosphate. This might indicate that either the energy or some product released during hydrolysis causes a conformational change that alters the activation state of the enzyme. The maximal observed rate constant for this change (1 sec^{-1}) is almost 150 times lower than K_{cat} for hydrolysis but similar to the rate constant for the release of bound nucleotides (Strotmann and Bickel-Sandkötter, 1977). Preliminary findings indicate that ADP might be involved in the control of acceleration. A 20-fold decrease in the rate constant of acceleration is caused by preincubation of CF_1 with micromolar concentrations of divalent metal ions. This concentration range is similar to the range for K_i for competitive inhibition of ATPase by free Mn^{2+} and might indicate that the modulation is caused by binding to the two tight binding sites of Mn^{2+} to CF_1 (Hochman *et al.*, 1976). This effect of divalent cations might be similar to the observed acceleration of the decay of the light-triggered state of ATPase in chloroplasts by Mg^{2+} , whereas the acceleration itself might be similar to the observed increased lag in the quenching of fluorescence of 9-aminoacridine as a function of the time between light-triggering and the addition of ATP, which was suggested to be a result of autocatalysis (Bakker-Grunwald and van Dam, 1973). The observed changes in the concentration of Mg^{2+} ions in the stroma as a result of light-induced ion transport across the thylakoid membrane (Krause, 1977) might place a physiological significance on the control of ATPase activity by divalent metal ions.

V. Nucleotide Binding and Conformational Changes

A thorough analysis of CF_1 -adenine nucleotide interactions with the enzyme either in solution or membrane-bound will aid in the elucidation of the mechanism of the ATPase complex. Although it would seem that the determination of the number of, and dissociation constants for, the equilibrium binding sites of soluble CF_1 in latent and active form should be comparatively straightforward, the results from several laboratories have been rather different (see Harris, 1978; McCarty, 1979a, for a detailed discussion of these early results). These discrepancies may largely be explained in terms of the prior treatment of the enzyme and the assay conditions used (Bruist and Hammes, 1981).

Two major factors have contributed to the confusion about the CF_1 binding sites: one, variations in the contents of bound nucleotides (Harris and Slater, 1975) and two, exchange between free and bound nucleotides, which might be mistaken for binding to an empty site (Carrier and Hammes, 1979). Although Harris and Slater (1975) reported that isolated CF_1 contains about equimolar amounts of ATP and ADP, which could not be removed by prolonged dialysis, others have generally found that little ATP is associated with the enzyme and that it contained about 1 ADP per CF_1 . Storage of the enzyme as the ammonium sulfate precipitate causes a slow release of bound ATP, but not of bound ADP, from the enzyme (Bruist and Hammes, 1981). The nucleotide content and binding properties of freshly isolated CF_1 preparations or those exposed only briefly to ammonium sulfate would thus be expected to be different from those stored as ammonium sulfate precipitates.

Three distinct nucleotide binding sites on CF_1 have been so far uncovered. Site 1 contains the ADP that remains bound to CF_1 , even after extensive dialysis or chromatography on long columns of Sephadex G-25 and repeated precipitation with $(NH_4)_2SO_4$. At least partial denaturation is required to remove this ADP. The ADP bound to this site undergoes a slow exchange with ADP in the medium (Carrier and Hammes, 1979) to give about 1 mole ADP bound per mole CF_1 . This exchange does not require the presence of a divalent cation. An even slower exchange occurs with ATP. Hydrolysis of the ATP either before or concurrently with binding occurs since ADP is bound to the enzyme. The half-times for these exchanges with either ADP or ATP (100 μM) are hours (Carrier and Hammes 1979; Bruist and Hammes, 1981). Remarkably, ADP remains bound to CF_1 after treatment at 60°C for 4 min in the presence of 40 mM ATP and 5 mM dithiothreitol. This treatment

activates the ATPase of the enzyme and results in a much faster exchange of ADP (half-time about 30 min). ATP exchange in the presence of Ca^{2+} was multiphasic, probably in part due to the release of ADP, which inhibits the ATPase activity. The antibiotic tentoxin also induces ATPase activity and exchange (Selman and Selman-Reimer, 1979) at high concentrations. The most rapid phase of exchange with ATP, however, had a half-time of about 15 sec. Shoshan *et al.* (1978) previously reported that the rate of binding of formycin triphosphate, a fluorescent ATP analog, was markedly enhanced by activation of the ATPase. Since the turnover of ATPase is about 20 sec^{-1} under these conditions, it seems unlikely that site 1 is a catalytic site. This conclusion is supported by the observation (Bruist and Hammes, 1981) that GTP exchanges very poorly with bound ADP even though it is a reasonably good substrate for the enzyme (Bennun and Avron, 1965; McCarty *et al.*, 1978).

Site 2 can probably best be characterized as a Mg^{2+} -ATP binding site with a very low dissociation constant. Since the binding to this site is relatively rapid, it may be assayed without complications from exchange with bound nucleotide. Adenosine triphosphate binding to this site is seen only in the presence of Mg^{2+} (Shoshan *et al.*, 1978) and occurs even with equimolar concentrations of ATP and CF_1 . With a fivefold molar excess of ATP, 1 mole of ATP is bound per mole of CF_1 at equilibrium. ATP bound in this manner is not removed by passage of the CF_1 through a column of Sephadex G-50. Mg^{2+} -guanosine triphosphate (GTP) also binds to this site. There appears to be little change in the properties of this site upon activation of the ATPase. Moreover, Ca^{2+} -ATP does not displace the bound ATP in the active enzyme, suggesting that site 2 has no direct catalytic role (Bruist and Hammes, 1981).

Site 3 binds a number of different nucleotides including ATP, ADP, adenylylimidodiphosphate, etheno-ATP and ADP, and GTP, with dissociation constants in the neighborhood of $2 \mu\text{M}$. The nucleotide bound to this site dissociates readily when the enzyme is passed through a Sephadex column. When site 2 is vacant, 2 moles of nucleotide are bound at equilibrium. Although Cantley and Hammes (1975a) and Bruist and Hammes (1981) find these two sites to be equivalent, Girault and Galmiche (1977) and VanderMeulen and Govindjee (1977) found some evidence for cooperative interactions. This difference remains to be explained. When site 2 contains ATP, only 1 ADP binds to the enzyme, suggesting that the two sites seen in the ATP-depleted enzyme are not equivalent. Relatively little has been published on the nucleotide binding by F_1 molecules from photosynthetic bacteria.

Tiefert *et al.* (1977) found that active CF_1 bound about 2 ADP/mole

with half-maximal binding at 2 and 28 μM ADP. These results are not necessarily inconsistent with those of G. G. Hammes' research group. Since the active enzyme was used, exchange with the ADP bound to site 1 would be nearly complete in the 2-hour incubation. This exchange could correspond to the weaker binding site. If the ATP site (site 2) were filled, only one ADP would bind to the enzyme, with a dissociation constant of 2 μM .

Cantley and Hammes (1975a) reported that heat-activation of CF_1 exposed an additional site for adenylylimidodiphosphate with a dissociation constant of 7 μM . It seems likely that this binding is the consequence of exchange with ADP bound to site 1.

The evidence gathered so far argues against a direct catalytic function for any of the three sites. The catalytic site (or sites) are, apparently, not readily detected in equilibrium binding experiments, and different approaches may have to be used to detect them.

The interactions of bound CF_1 with nucleotides have been studied by several different approaches. Low concentrations of ADP or ATP enhance proton uptake (McCarty *et al.*, 1971) and protect (Magnusson and McCarty, 1975) phosphorylation from inhibition caused by a light-dependent incorporation of *N*-ethylmaleimide into the γ subunit of CF_1 (McCarty *et al.*, 1972; McCarty and Fagan, 1973). The light-dependent inhibition of ATPase activity of CF_1 by trinitrobenzene sulfonic acids is also affected by adenine nucleotides (Oliver and Jagendorf, 1976) and ADP is required for the development of sulfate inhibition of photophosphorylation (Ryrie and Jagendorf, 1971).

Harris and Slater (1975) first showed that nucleotides bound to CF_1 in thylakoids undergo a rapid exchange with medium ADP when the thylakoids are illuminated. The exchange is sensitive to uncouplers, inhibitors of electron transport and to reagents that block proton conductance through F_0 . Strotmann *et al.* (1979) showed that the amount of ADP bound to CF_1 in the light is substantially less than that bound in the dark. The amount of ATP bound in the light was lower than that of ADP (Shoshan and Selman, 1979). Strotmann *et al.* (1979) concluded that ADP exchange can be described by the following sequence of steps:

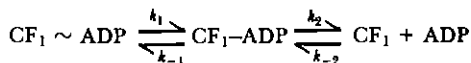

where $CF_1 \sim ADP$ stands for the tight complex, the predominant form in the dark; CF_1-ADP , for a loose complex; and CF_1 , for ADP-free enzyme. Rate constants for the individual steps were calculated. It was found that the initial rate of ADP binding to the depleted enzyme was

much slower than ADP turnover during photophosphorylation. Moreover, the nucleotide specificity of exchange is different from that of photophosphorylation. A notable example is 2,2'-[1-(9-adenyl)-1'-diphosphoryloxymethyl]dihydroxydiethyl ether (rrO-ADP), which is not phosphorylated at all, but binds to the exchange site in the light (Boos *et al.*, 1976).

Although the exchange site does not appear to be directly involved in catalysis, there are indications that it may be involved in the expression of the Mg^{2+} -ATP activity of the membrane-bound enzyme as discussed in Section IV,B.

The site in CF_1 in thylakoids that undergoes energy-dependent exchange bears many similarities to the exchangeable site in soluble CF_1 (site I). The nucleotide specificity of the sites is more restricted than that of the catalytic sites. Moreover, tentoxin induces the exchange in both the soluble and membrane-bound enzymes (Selman and Selman-Reimer, 1979), and the exchange is very slow when the enzyme (either in solution or membrane-bound) is not activated. Hydrolysis of ATP to form tightly bound ADP occurs in both the soluble (Carlier and Hammes, 1979) and thylakoid membrane-bound enzyme. Site I may also be involved in the stimulation of proton uptake by ADP and ATP and in the protection of phosphorylation from inhibition by reagents that modify functional groups on membrane-bound CF_1 . The conformation of the nucleotide-depleted form of CF_1 is likely to be different from that of the form that has bound ADP. Changes in the conformation of CF_1 upon the formation of an electrochemical proton gradient across thylakoid membranes may explain why tightly bound ADP is converted to a loosely bound form. The conformational state of CF_1 in illuminated thylakoids, especially at high proton gradients, renders the thylakoids more leaky to protons and groups in CF_1 more reactive with modifying reagents. In the presence of ADP (or ATP), less of the nucleotide-depleted form would be present, and the proton leak and increased reactivity would be reduced.

Little is known about CF_1 - P_i interactions. P_i enhances the protection against inhibition of phosphorylation by *N*-ethylmaleimide, which is afforded by ADP and ATP (Magnusson and McCarty, 1975). Shoshan and Strotmann (1980) showed that P_i enhances the affinity for ADP binding to the exchange site in membrane-bound CF_1 as well as the rate of postillumination ADP binding. No effect on ATP binding was detected. Half-maximal P_i stimulation of ADP binding occurred at about 30 μM P_i , a concentration substantially below the apparent K_m of P_i for photophosphorylation (about 300 μM). Thus, there may be several classes of P_i sites on CF_1 in the membrane. So far attempts to show tight binding of

P_i to soluble CF_1 (latent and activated) have failed (Tiefert *et al.*, 1977; S. R. Ketcham and R. E. McCarty, unpublished).

The extrapolation of the results from studies on nucleotide and P_i binding to soluble CF_1 to the bound enzyme may be difficult. For example, although adenylylimidodiphosphate is a potent competitive inhibitor of the ATPase activity of the soluble enzyme (Cantley and Hammes, 1975a), the light- and dithiothreitol- activated membrane-bound ATPase activity is poorly inhibited by this nucleotide analog (McCarty *et al.*, 1978). In contrast, GTP hydrolysis by activated thylakoids is strongly inhibited by adenylylimidodiphosphate. In the presence of this inhibitor the rate of GTP hydrolysis as a function of GTP concentration becomes sigmoidal.

Adenosine monophosphate (AMP) neither binds to soluble CF_1 nor interferes with light-induced nucleotide exchange. A very slow transphosphorylation of ADP to form AMP and ATP is, however, catalyzed by the enzyme in solution (Roy and Moudrianakis, 1971). AMP has been proposed to be the primary phosphoryl acceptor in photophosphorylation (Roy and Moudrianakis, 1971; Tiefert and Moudrianakis, 1979). The bound ADP formed was suggested to transfer terminal phosphate to medium ADP to form ATP. Since, however, ATP can become labeled by medium $^{32}P_i$ more rapidly in the light than ADP (Vinkler *et al.*, 1978), this pathway for ATP formation seems unlikely. Vambutas and Bertsch (1976) reported that AMP stimulates an apparent light-dependent $^{32}P_i$ -ATP exchange in thylakoids and invoked Moudrianakis' transphosphorylation mechanism to explain this activity. Adenylate kinase catalyzes the formation of ADP from AMP and ATP, and its action could explain the AMP-induced increase in $^{32}P_i$ esterification in the presence of ATP. The extent of [3H]AMP incorporation into ATP was only about 10% of that of $^{32}P_i$, a finding that seemingly excludes ADP formation by adenylate kinase action. However, the AMP stimulation of $^{32}P_i$ incorporation under these conditions was inhibited when an ATP regenerating system was present and by a specific inhibitor of adenylate kinase (R. E. McCarty, unpublished). The apparent low incorporation of AMP into the ATP made in the light may be explained by the fact that thylakoid preparations are contaminated with a very active ADP-ATP exchange enzyme (Kahn and Jagendorf, 1961). The small amount of [3H]ADP formed by the adenylate kinase-catalyzed reaction could exchange with the large excess of unlabeled ATP, resulting in a substantial dilution of the label. Thus, although the possibility cannot be totally excluded that AMP may be the primary phosphate acceptor, there is little convincing evidence in its favor.

One other approach to the binding of nucleotides to membrane-

bound CF_1 , employed in Boyer's laboratory, merits discussion. A synopsis of these experiments is given by Rosen *et al.* (1979). Several methods for stopping phosphorylation by illuminated thylakoids were used in combination with rapid mixture techniques in an attempt to detect ATP that might be bound to a catalytic site (or sites). Thylakoids were collected by filtration after illumination, in the presence of ADP and $^{32}P_i$, and treatment with either EDTA or the uncoupler NH_4Cl . Unbound $^{32}P_i$ and $[^{32}P]ATP$ were removed by washing; bound nucleotides were released by $HClO_4$ treatment, and then the extracts were analyzed for $[^{32}P]ATP$. Two classes of bound $[^{32}P]ATP$ were detected. One, labeled over a period of seconds, forms too slowly to be directly involved in catalysis. The other class, corresponding to about 0.2 mole $[^{32}P]ATP$ /mole CF_1 , was labeled to near its maximum extent within 20 msec after addition of $^{32}P_i$ to a suspension of thylakoids previously illuminated 5 sec in the presence of saturating amounts of ADP and P_i . Non labeled P_i also rapidly chased the ^{32}P from the bound ATP. Under steady state phosphorylating conditions, the amount of bound ATP was estimated through the use of an ATP-trapping system—glucose and hexokinase. Assuming that ATP bound to CF_1 is not accessible to hexokinase, the amount of $[^{32}P]ATP$ in the reaction mixture at infinite hexokinase concentrations should be a measure of the amount of ATP bound. Plots of ATP bound per CF_1 versus the reciprocal of the hexokinase concentration were linear, and the intercepts were used to estimate bound ATP at infinite hexokinase concentration. At an ADP level not too far from saturation, approximately 1 ATP per CF_1 was bound. The bound ATP assayed in this manner in the presence of only $8 \mu M$ ADP was formed rapidly. This observation, combined with the previous finding (Smith *et al.*, 1976) that up to approximately 0.7 mole of P_i and of ADP are committed to phosphorylation suggests that there may be more than one catalytic site active on each ATPase complex during ATP synthesis. The amount of P_i committed for light-dependent ATP synthesis was, however, less than 0.3 mole/mole CF_1 . Moreover, bound ATP may become labeled in both the γ and β positions (Harris, 1978). Since the position of the label in ATP was not determined in the experiments of Rosen *et al.* (1979), the estimate of 1 bound ATP/ CF_1 may be too high. Furthermore, there may be variation in the CF_1 content, expressed on a per milligram of Chl basis, from preparation to preparation. Thus, these data in themselves do not provide convincing evidence for the operation of more than one catalytic site per CF_1 . Nonetheless, the rapid mixing approach is likely to yield further interesting clues about the nature of the rapidly formed bound ATP.

Energy-dependent changes in the structure of CF_1 bound to thylakoids clearly take place. The oldest demonstration of this phenomenon

was made by Ryrie and Jagendorf (1972). Thylakoids suspended in a medium containing $^3\text{H}_2\text{O}$ were energized either by illumination or by the formation of artificial transmembrane proton gradients, or were kept in the dark. CF_1 isolated and purified from "energized" membranes contains as much as 100 ^3H per CF_1 , whereas that from membranes exposed to ^3H in the dark contained very little ^3H . Groups bearing exchangeable hydrogens are likely to become exposed to the solvent in the light and become inaccessible to solvent when the thylakoids are returned to the dark. This light-dependent tritium exchange was inhibited by uncouplers, by electron transport inhibitors, and by ADP and P_i . The energy-dependent increase in the reactivity of CF_1 with variety of protein modifying reagents has some similarity to tritium exchange and supports the concept that CF_1 undergoes conformational changes upon illumination of thylakoids (see McCarty, 1979a, for a discussion of these experiments; also see Jagendorf, 1975).

The function(s) of the energy-dependent changes in CF_1 structure remain elusive, but it is tempting to speculate that they may be involved in the conversion of the enzyme to its active form (see Section IV,B). Most of the methods used to detect energy-dependent changes in CF_1 were not suitable for kinetic analysis, and, therefore, whether the rate of these changes is fast enough for their participation in either phosphorylation or activation of the enzyme was not known. However, R. Wagner and W. Junge (personal communication) have employed a new technique to monitor the kinetics of CF_1 structure changes. They incubated thylakoids with eosine thiocyanate in the light or dark and isolated the CF_1 from the treated membranes. After binding the modified CF_1 preparations to CF_1 -depleted membranes, the kinetics of the oxygen quenching of the flash-induced eosine triplet was investigated. Binding of eosine to CF_1 during illumination of thylakoids resulted in slower quenching than was obtained when the reagent was bound in the dark. This result indicates that the eosine moiety in the CF_1 from light-treated thylakoids is less accessible to oxygen. Actinic illumination induces a rapid increase in the rate of quenching of the eosine triplet in thylakoids bearing CF_1 from thylakoids previously reacted with eosine thiocyanate in the light. This change, which took place within a few msec, is affected by ADP and P_i . Thus, the changes reported by the eosine quenching are probably kinetically consistent with conformational changes that might be involved either with the mechanism of catalysis or the regulation of enzyme activation.

The investigations of nucleotide binding to, and structural changes in, CF_1 have raised a number of very interesting questions. Clearly, CF_1 has multiple nucleotide binding sites. The functions of these sites are not yet readily apparent, but it seems possible that at least one site functions

in the regulation of the expression of ATPase activity. Others could function in the assembly of the subunits of the enzyme during its biosynthesis. Whether the energy-dependent structural alterations in bound CF_1 are an essential part of the mechanism of photophosphorylation remains to be elucidated.

VI. Postulated Mechanisms

In spite of the large body of evidence concerning the catalysis of ATP formation and hydrolysis by proton translocating ATPases, the details of the mechanisms at molecular level are still not known. The fact that the reversible ATPase is a multipolypeptide system that catalyzes ATP formation only in lipid vesicles that are required for preservation of proton gradients complicates these studies.

It is generally accepted that electrochemical proton gradients drive ATP synthesis and that interaction of protons with the enzyme either directly or indirectly is involved in the catalysis. In the detailed molecular mechanism suggested by Mitchell (1974), a direct protonation of phosphate by protons specifically channeled through F_0 to the active site causes formation of a positively charged phosphorous center. A nucleophilic attack of $ADP-O^-$ displaces an O^{2-} group thus forming ATP. Since O^{2-} is not a good leaving group, it was suggested that an excellent leaving group such as $-OH_2^+$ could be formed by two successive protonations of phosphate attached to Mg^{2+} . Boyer (1975) pointed out that energetically protonation of $P=O$ oxygen is more favorable than the formation of an oxonium. Yet even if $P=O$ is protonated the positive phosphorous could undergo nucleophilic attack by $ADP-O^-$, which will result in elimination of water and a formation of ATP (Mitchell, 1975). Lysyl and arginyl residues, shown by chemical modification to be essential for catalysis of ATPase activity in CF_1 (Section IV,A), might be involved in the process of protonation of the phosphate and the formation of a positive phosphorous center. Protons might also be involved in conformational changes and charge neutralization which could facilitate movement of substrates and products through the active site.

Indirect involvement of protons was proposed by Boyer (1977) and Slater (1977), who suggested that proton gradient causes conformational changes in the enzyme that induces ATP synthesis. They proposed that the tightly bound substrates spontaneously form a tightly bound ATP, whereas energy is required for the release of the product. The suggestion was based in part on the finding of tightly bound nucleotides that are released upon energization. Subsequent detailed kinetic mea-

surements of phosphorylation, the finding of uncoupler insensitive water phosphate oxygen exchange and the observation that this exchange, which can be catalyzed by soluble F_1 , is modulated by ATP gave rise to the alternating sites proposal (Hackney and Boyer, 1978; Hutton and Boyer, 1979; Rosen *et al.*, 1979). Energy-induced conformational changes promote both binding of substrates in one site that favors ATP synthesis, while at the same time releases tightly bound ATP from the alternating site. However, a detailed molecular mechanism for the catalysis was not proposed.

Racker (1977) proposed that Mg^{2+} -induced conformational changes in the enzyme cause a formation of a phosphoryl enzyme intermediate. Although a covalently bound intermediate is yet to be found, this suggestion stems from an analogy to the Ca^{2+} -ATPase of sarcoplasmic reticulum where such an intermediate was found. Protons that displace the Mg^{2+} ions cause a change in conformation, which allows the transphosphorylation of ATP. Once ATP is released from the enzyme, re-binding of Mg^{2+} ions starts a new cycle. The existence of two sites of tightly bound Mn^{2+} ions in CF_1 (Hochman *et al.*, 1976), and the existence of a dicyclohexylcarbodiimide modified essential carboxyl group in F_1 (Gepshtein *et al.*, 1978; Shoshan and Selman, 1980; Arana and Vellejos, 1980), was demonstrated. However, the relevance of these findings to the proposed mechanism is not established.

Tightly bound ADP, found to be formed by phosphorylation of AMP in CF_1 (Roy and Moundrianakis, 1971), was suggested to be the prime phosphate acceptor in photophosphorylation (however, see also Section V). Nelson *et al.*, (1977b) suggested that this special ADP is a cofactor that is transiently phosphorylated to serve as a phosphoryl donor to ADP at the active site. External ADP arrives at the active site on the β subunit from a tight binding site on the α subunit by $\Delta\bar{\mu}_{H^+}$ -mediated conformational changes.

These various hypotheses explain a great number of observations and were instrumental in the design of many experiments that yielded valuable information regarding the properties and the mechanism of catalysis of ATP formation by the proton ATPase. Yet none of these proposals are able to describe the detailed molecular events that lead to ATP synthesis.

Acknowledgments

We thank M. Baltscheffsky, A. Binder, J. B. Jackson, W. Junge, Z. Gromet-Elihanan, N. Nelson, and C. S. Yocum for providing preprints and reprints of their work. Thanks are also due to Joyce Broadhead for her typing of the manuscript.

REFERENCES

- Andreo, C. S., and Vallejos, R. H. (1977). *FEBS Lett.* **78**, 207-210.
- Andreo, C. S., Ravizzini, R. A., and Vallejos, R. H. (1979). *Biochim. Biophys. Acta* **547**, 370-379.
- Arana, J. L., and Vallejos, R. H. (1980). *FEBS Lett.* **113**, 319-322.
- Ausländer, W., and Junge, W. (1975). *FEBS Lett.* **59**, 310-315.
- Avron, M. (1963). *Biochim. Biophys. Acta* **77**, 699-702.
- Avron, M. (1978). *FEBS Lett.* **96**, 225-232.
- Baccarini-Melandri, A., and Melandri, B. A. (1971). In "Methods in Enzymology" (A. San Pietro, ed.), Vol. 23, pp. 556-561. Academic Press, New York.
- Baccarini-Melandri, A., Fabbri, E., and Melandri, B. A. (1975). *Biochim. Biophys. Acta* **376**, 82-95.
- Baccarini-Melandri, A., Casadio, R., and Melandri, B. A. (1977). *Eur. J. Biochem.* **78**, 389-402.
- Baird, B. A., and Hammes, G. G. (1976). *J. Biol. Chem.* **251**, 6953-6962.
- Baird, B. A., and Hammes, G. G. (1979). *Biochim. Biophys. Acta* **549**, 31-54.
- Bakker-Grunwald, T. (1977). *Encycl. Plant Physiol., New Ser.* **5**, 369-373.
- Bakker-Grunwald, T., and van Dam, K. (1973). *Biochim. Biophys. Acta* **292**, 808-814.
- Baltscheffsky, M., and Lundin, A. (1979). In "Cation Flux across Biomembranes" (Y. Mukohata and L. Packer, eds.), pp. 209-218. Academic Press, New York.
- Bengis, C., and Nelson, N. (1977). *J. Biol. Chem.* **250**, 2783-2788.
- Bengis-Garber, C., and Gromet-Elhanan, Z. (1979). *Biochemistry* **18**, 3577-3581.
- Bennun, A., and Avron, M. (1965). *Biochim. Biophys. Acta* **109**, 117-127.
- Bennun, A., and Racker, E. (1969). *J. Biol. Chem.* **244**, 1325-1330.
- Binder, A., and Bachofen, R. (1979). *FEBS Lett.* **50**, 91-94.
- Binder, A., Jagendorf, A. T., and Ngo, E. (1978). *J. Biol. Chem.* **253**, 3094-3100.
- Boos, K.-S., Lüstorf, J., Schlimme, E., Hesse, M., and Strotmann, H. (1976). *FEBS Lett.* **71**, 124-129.
- Boyer, P. D. (1975). *FEBS Lett.* **50**, 91-94.
- Boyer, P. D. (1977). *Annu. Rev. Biochem.* **46**, 957-966.
- Bruist, M., and Hammes, G. G. (1981). *Biochemistry* **20**, 6298-6305.
- Cantley, L. C., and Hammes, G. G. (1975a). *Biochemistry* **14**, 2968-2975.
- Cantley, L. C., and Hammes, G. G. (1975b). *Biochemistry* **14**, 2976-2981.
- Carlier, M. F., and Hammes, G. G. (1979). *Biochemistry* **18**, 3446-3451.
- Carmeli, C. (1969). *Biochim. Biophys. Acta* **189**, 256-266.
- Carmeli, C. (1970). *FEBS Lett.* **7**, 297-300.
- Carmeli, C., and Avron, M. (1966). *Biochem. Biophys. Res. Commun.* **24**, 923-928.
- Carmeli, C., and Lifshitz, Y. (1972). *Biochim. Biophys. Acta* **267**, 86-95.
- Carmeli, C., and Racker, E. (1973). *J. Biol. Chem.* **248**, 8281-8287.
- Carmeli, C., Lifshitz, Y., and Gepshtein, A. (1975). *Biochim. Biophys. Acta* **376**, 249-258.
- Carmeli, C., Lifshitz, Y., and Gutman, M. (1979). In "Cation Flux across Biomembranes" (Y. Mukohata and L. Packer, eds.), pp. 249-259. Academic Press, New York.
- Casadio, R., Baccarini-Melandri, A., Zannoni, D., and Melandri, B. A. (1974). *FEBS Lett.* **49**, 203-207.
- Chance, B., Crofts, A. R., Nishimura, M., and Prince, B. (1970). *Eur. J. Biochem.* **13**, 364-374.
- Cogdell, R. J., Jackson, J. B., and Crofts, A. R. (1972). *Bioenergetics* **4**, 413-429.
- Crofts, A. R. (1966). *Biochem. Biophys. Res. Commun.* **24**, 725-731.
- Davenport, J. W. (1982). Ph.D. thesis, Cornell University.

- Davenport, J. W., and McCarty, R. E. (1981). *J. Biol. Chem.* **256**, 8947-8954.
- Deters, D. W., Racker, E., Nelson, N., and Nelson, H. (1975). *J. Biol. Chem.* **250**, 1041-1047.
- Edwards, P. A., and Jackson, J. B. (1976). *Eur. J. Biochem.* **62**, 7-14.
- Farron, F. (1970). *Biochemistry* **9**, 3823-3829.
- Farron, F., and Racker E. (1970). *Biochemistry* **9**, 3829-3836.
- Fiolet, J. T. W., Bakker, E. P., and van Dam, H. (1974). *Biochim. Biophys. Acta* **368**, 432-445.
- Gaensslen, R. E., and McCarty, R. E. (1971). *Arch. Biochem. Biophys.* **147**, 55-65.
- Gepshtein, A., and Carmeli, C. (1977). *Eur. J. Biochem.* **74**, 463-469.
- Gepshtein, A., Hochman, Y., and Carmeli, C. (1975). *Proc. Int. Congr. Photosynth.*, 3rd, 1974 pp. 1189-1197.
- Gepshtein, A., Carmeli, C., and Nelson, N. (1978). *FEBS Lett.* **85**, 219-223.
- Girault, G., and Galmiche, J.-M. (1977). *Eur. J. Biochem.* **77**, 501-510.
- Govindjee, ed. (1982). "Photosynthesis: Development, Carbon Metabolism, and Plant Productivity," Vol. II. Academic Press, New York.
- Gromet-Elhanan, Z., and Leiser, M. (1978). In "The Proton and Calcium Pumps" (G. F. Azzone, M. Avron, J. C. Metcalfe, E. Quagliariello, and N. Silliprandi, eds.), pp. 81-92. Elsevier, Amsterdam
- Hackney, D. D., and Boyer, P. D. (1978). *J. Biol. Chem.* **253**, 3164-3170.
- Harris, D. A. (1978). *Biochim. Biophys. Acta* **463**, 245-273.
- Harris, D. A., and Crofts, A. R. (1978). *Biochim. Biophys. Acta* **502**, 87-102.
- Harris, D. A., and Slater, E. C. (1975). *Biochim. Biophys. Acta* **387**, 335-348.
- Heber, U. (1973). *Biochim. Biophys. Acta* **305**, 140-152.
- Hind, G., and Jagendorf, A. T. (1965). *J. Biol. Chem.* **240**, 3195-3201.
- Hind, G., Nakatani, H. Y., and Izawa, S. (1974). *Proc. Natl. Acad. Sci. U.S.A.* **71**, 1484-1488.
- Hochman, Y., and Carmeli, C. (1971). *FEBS Lett.* **13**, 36-40.
- Hochman, Y., and Carmeli, C. (1981). In press.
- Hochman, Y., and Carmeli, C. (1982). In preparation.
- Hochman, Y., Lanir, A., and Carmeli, C. (1976). *FEBS Lett.* **61**, 255-259.
- Hochman, Y., Lanir, A., Werber, M. M., and Carmeli, C. (1979). *Arch. Biochem. Biophys.* **192**, 138-147.
- Holowka, D. A., and Hammes, G. G. (1977). *Biochemistry* **16**, 5538-5545.
- Horio, T., Nishikawa, K., Katsumata, M., and Yamashita, J. (1965). *Biochim. Biophys. Acta* **94**, 371-382.
- Hutton, R. L., and Boyer, P. D. (1979). *J. Biol. Chem.* **254**, 9990-9993.
- Inoue, Y., Kobayashi, Y., Shibata, K., and Heber, U. (1978). *Biochim. Biophys. Acta* **504**, 145-152.
- Isaev, P. I., Liberman, E. A., Samuilov, V. D., Skalachev, V. P., and Tsofina, L. M. (1970). *Biochim. Biophys. Acta* **21**, 22-29.
- Izawa, S., and Good, N. E. (1969). *Prog. Photosynth. Res., Proc. Int. Congr. [1st]*, 1968 pp. 1288-1298.
- Jackson, J. B., and Crofts, A. R. (1969). *Eur. J. Biochem.* **10**, 226-237.
- Jackson, J. B., Crofts, A. R., and von Stedingk, L.-V. (1968). *Eur. J. Biochem.* **6**, 41-54.
- Jagendorf, A. T. (1975). In "Bioenergetics of Photosynthesis" (Govindjee, ed.), pp. 413-492. Academic Press, New York.
- Jagendorf, A. T., and Hind, G. (1963). *N. A. S.-N. R. C., Publ.* **1145**, 599-610.
- Jagendorf, A. T., and Smith, M. (1962). *Plant Physiol.* **37**, 135-141.
- Johansson, B. C., and Baltscheffsky, M. (1975). *FEBS Lett.* **53**, 221-224.
- Johansson, B. C., Baltscheffsky, M., Baltscheffsky, H., Baccarini-Melandri, A., and Melandri, B. A. (1973). *Eur. J. Biochem.* **40**, 109-117.

- Junge, W. (1970). *Eur. J. Biochem.* **14**, 582–592.
- Junge, W. (1977). *Annu. Rev. Plant Physiol.* **28**, 503–536.
- Kagawa, Y. (1978). *Biochim. Biophys. Acta* **505**, 45–94.
- Kagawa, Y., and Racker, E. (1971). *J. Biol. Chem.* **246**, 5477–5487.
- Kagawa, Y., Sone, N., Hirata, H., Yoshida, M., Rögner, M., and Ohta, S. (1979). In "Membrane Bioenergetics" (C. P. Lee, G. Schatz, and L. Ernster, eds.), pp. 177–188. Addison-Wesley, Reading, Massachusetts.
- Kahn, J. S., and Jagendorf, A. T. (1961). *J. Biol. Chem.* **236**, 940–943.
- Kaplan, J. H., Uribe, E., and Jagendorf, A. T. (1967). *Arch. Biochem. Biophys.* **120**, 365–375.
- Keister, D., and Minton, N. J. (1971). *Arch. Biochem. Biophys.* **147**, 330–338.
- Kraayenhoff, R., Groot, G. S. P., and van Dam, K. (1969). *FEBS Lett.* **4**, 125–128.
- Krause, G. H. (1977). *Biochim. Biophys. Acta* **460**, 500–510.
- Leiser, M., and Gromet-Elhanan, Z. (1974). *FEBS Lett.* **43**, 267–270.
- Leiser, M., and Gromet-Elhanan, Z. (1977). *Arch. Biochem. Biophys.* **178**, 79–88.
- Lien, S., and Racker, E. (1971a). In "Methods in Enzymology" (A. San Pietro, ed.), Vol. 23, 547–555. Academic Press, New York.
- Lien, S., and Racker, E. (1971b). *J. Biol. Chem.* **246**, 4298–4307.
- Livne, A., and Racker, E. (1969). *J. Biol. Chem.* **244**, 1332–1338.
- Lucke, F. K., and Klemme, J. H. (1976). *Z. Naturforsch., C: Biosci.* **31C**, 272–279.
- Lynn, W. S., and Straub, K. K. (1969). *Proc. Natl. Acad. Sci. U.S.A.* **63**, 540–56.
- McCarty, R. E. (1978a). *Curr. Top. Bioenerg.* **7**, 245–278.
- McCarty, R. E. (1978b). In "The Proton and Calcium Pumps" (G. F. Azzone, M. Avron, J. C. Mecalfe, E. Quagliariello, and N. Silliprandi, eds.), pp. 65–70. Elsevier, Amsterdam.
- McCarty, R. E. (1979a). *Annu. Rev. Plant Physiol.* **30**, 79–104.
- McCarty, R. E. (1979b). *Trends Biochem. Sci.* **4**, 28–30.
- McCarty, R. E., and Fagan, J. (1973). *Biochemistry* **12**, 1503–1507.
- McCarty, R. E., and Portis A. R., Jr. (1976). *Biochemistry* **15**, 5110–5114.
- McCarty, R. E., and Racker, E. (1966). *Brookhaven Symp. Biol.* **19**, 202–214.
- McCarty, R. E., and Racker, E. (1967). *J. Biol. Chem.* **242**, 3435–3439.
- McCarty, R. E., and Racker, E. (1968). *J. Biol. Chem.* **243**, 129–137.
- McCarty, R. E., Furhman, J. S., and Tsuchiya, Y. (1971). *Proc. Natl. Acad. Sci. U.S.A.* **68**, 2522–2626.
- McCarty, R. E., Pittman, P. R., and Tsuchiya, Y. (1972). *J. Biol. Chem.* **243**, 129–137.
- McCarty, R. E., Magnusson, R. P., and Wong, R. (1978). In "Frontiers of Biological Energetics" (P. L. Dutton and J. S. Leigh, eds.), Vol. 1, pp. 477–483. Academic Press, New York.
- Magnusson, R. P., and McCarty, R. E. (1975). *J. Biol. Chem.* **250**, 2593–2598.
- Melandri, B. A., Baccarini-Melandri, A., Gest, H., and San Pietro, A. (1971). In "Energy Transduction in Respiration and Photosynthesis" (E. Quagliariello, S. Papa, and C. S. Rossi, eds.), pp. 593–608. Adriatica Editrici, Bari, Italy.
- Melandri, B. A., Baccarini-Melandri, A., Crofts, A. R., and Cogdell, R. (1972). *FEBS Lett.* **24**, 141–145.
- Melandri, B. A., De Santio, A., Venturoli, G., and Baccarini-Melandria, A. (1978). *FEBS Lett.* **95**, 130–134.
- Mills, J. D., and Hind, G. (1979). *Biochim. Biophys. Acta* **597**, 455–462.
- Mills, J. D., Mitchell, P., and Schurman, P. (1980). *FEBS Lett.* **112**, 173–177.
- Mitchell, P. (1961). *Nature (London)* **191**, 144–148.
- Mitchell, P. (1966). *Biol. Rev. Cambridge Philos. Soc.* **41**, 445–502.
- Mitchell, P. (1967). *Fed. Proc., Fed. Am. Soc. Exp. Biol.* **26**, 1370–1379.
- Mitchell, P. (1974). *FEBS Lett.* **43**, 189–194.

- Mitchell, P. (1975). *FEBS Lett.* **50**, 95–97.
- Moroney, J. V., and McCarty, R. E. (1981) In "Energy Coupling in Photosynthesis" (B. R. Selman and S. Selman-Reimer, eds.), pp. 169–174. Elsevier/North-Holland, New York.
- Moroney, J. V., Andreo, C. S., Vallejos, R. H., and McCarty, R. E. (1980). *J. Biol. Chem.* **255**, 6670–6674.
- Moudrianakis, E. N. (1968). *Fed. Proc., Fed. Am. Soc. Exp. Biol.* **27**, 1180–1185.
- Muller, H. W., Schwalern, V., Salzer, M., and Dosi, K. (1979). *Z. Naturforsch., C: Biosci.* **34C**, 38–45.
- Nelson, N. (1976). *Biochim. Biophys. Acta* **456**, 314–338.
- Nelson, N., and Broza, R. (1976). *Eur. J. Biochem.* **69**, 203–208.
- Nelson, N., and Eytan, E. (1979). In "Cation Flux across Biomembranes" (Y. Muhohata and L. Packer, eds.), pp. 409–416. Academic Press, New York.
- Nelson, N., and Hauska, G. A. (1979). In "Membrane Bioenergetics" (C. P. Lee, G. Schatz, and L. Ernster, eds.), pp. 189–202. Addison-Wesley, Reading, Massachusetts.
- Nelson, N., and Karny, O. (1976). *FEBS Lett.* **70**, 249–253.
- Nelson, N., Nelson, H., and Racker, E. (1972a). *J. Biol. Chem.* **247**, 7657–7662.
- Nelson, N., Nelson, H., and Racker, E. (1972b). *J. Biol. Chem.* **247**, 6506–6510.
- Nelson, N., Deters, D. W., Nelson, H., and Racker, E. (1973). *J. Biol. Chem.* **248**, 2049–2055.
- Nelson, N., Eytan, E., Notsani, B.-E., Sigrist, H., Sigrist-Nelson, H., and Gittler, C. (1977). *Proc. Natl. Acad. Sci. U.S.A.* **74**, 2375–2378.
- Nelson, N., Eytan, E., and Julian, C. (1978). *Proc. Int. Congr. Photosynth., 4th, 1977* pp. 559–570.
- Nelson, N., Nelson, H., and Schatz, G. (1980). *Proc. Natl. Acad. Sci. U.S.A.* **77**, 1361–1364.
- Neumann, J., and Jagendorf, A. T. (1964). *Arch. Biochem. Biophys.* **107**, 109–119.
- Oliver, D., and Jagendorf, A. T. (1976). *J. Biol. Chem.* **251**, 7168–7175.
- Oren, R., and Gromet-Elhanan, Z. (1979). *Biochim. Biophys. Acta* **548**, 106–118.
- Owers-Narhi, L., Robinson, S. J., DeRoo, C. S., and Yocum, C. F. (1979). *Biochem. Biophys. Res. Commun.* **90**, 1025–1031.
- Paradies, H. H., Zimmerman, T., and Schmidt, U. (1978). *J. Biol. Chem.* **253**, 8972–8979.
- Petrack, B., Cranston, A., Sheppy, F., and Farron, F. (1965). *J. Biol. Chem.* **240**, 906–912.
- Philosoph, S., Binder, A., and Gromet-Elhanan, Z. (1977). *J. Biol. Chem.* **252**, 8747–8752.
- Pick, U., and Racker, E. (1979). *J. Biol. Chem.* **254**, 2793–2799.
- Portis, A. R., Jr., and McCarty, R. E. (1974). *J. Biol. Chem.* **249**, 6250–6254.
- Portis, A. R., Jr., and McCarty, R. E. (1976). *J. Biol. Chem.* **251**, 1610–1617.
- Portis, A. R., Jr., Magnusson, R. P., and McCarty, R. E. (1975). *Biochem. Biophys. Res. Commun.* **64**, 877–884.
- Posorske, L., and Jagendorf, A. T. (1976). *Arch. Biochem. Biophys.* **177**, 276–283.
- Racker, E. (1977). *Annu. Rev. Biochem.* **46**, 1335–1340.
- Racker, E. (1979). In "Membrane Bioenergetics" (C. P. Lee, G. Schatz, and L. Ernster, eds.), pp. 569–591. Addison-Wesley, Reading, Massachusetts.
- Racker, E., and Stoerkenius, W. (1974). *J. Biol. Chem.* **249**, 662–663.
- Racker, E., Hauska, G. A., Lien, S., Berzborn, R. J., and Nelson, N. (1972). *Photosynth, Two Centuries Its Discovery Joseph Priestley, Proc. Int. Congr. Photosynth. Res., 2nd, 1971*, pp. 1097–1113.
- Ravizzini, R. A., Andreo, C. S., and Vallejos, R. H. (1980). *Biochim. Biophys. Acta* **591**, 135–141.
- Reimer, S., and Selman, B. R. (1979). *Biochim. Biophys. Acta.* **545**, 415–423.
- Rosen, G., Gresser, M., Vinkler, C., and Boyer, P. D. (1979). *J. Biol. Chem.* **254**, 10654 – 10661.

- Roy, H., and Moudrianakis, E. N. (1971). *Proc. Natl. Acad. Sci. U.S.A.* **68**, 2720-2724.
- Ryrie, I. J., and Jagendorf, A. T. (1971). *J. Biol. Chem.* **246**, 582-588.
- Ryrie, I. J., and Jagendorf, A. T. (1972). *J. Biol. Chem.* **247**, 4453-4459.
- Saphon, S., Jackson, J. B., and Witt, H. T. (1975). *Biochim. Biophys. Acta* **408**, 67-82.
- Schmid, R., Jagendorf, A. T., and Hulkower, S. (1977). *Biochim. Biophys. Acta* **462**, 177-186.
- Schmidt, U. D., and Paradies, H. H. (1977a). *Biochem. Biophys. Res. Commun.* **78**, 383-392.
- Schmidt, U. D., and Paradies, H. H. (1977b). *Biochem. Biophys. Res. Commun.* **78**, 1043-1052.
- Schröder, H., Muhle, H., and Rumberg, B. (1972). *Photosynth., Two Centuries Its Discovery* (Joseph Priestley, *Proc. Int. Congr. Photosynth. Res.*, 2nd, 1971 Vol. III, pp. 919-930.
- Schuldiner, S., Rottenberg, H., and Avron, M. (1972). *Eur. J. Biochem.* **25**, 64-70.
- Schwartz, M. (1968). *Nature (London)* **219**, 915-919.
- Selman, B. R., and Durbin, R. D. (1978). *Biochim. Biophys. Acta* **502**, 29-37.
- Selman, B. R., and Selman-Reimer, S. (1979). *FEBS Lett.* **97**, 301-304.
- Senior, A. L. (1979). In "Membrane Proteins in Energy Transduction" (R. A. Capaldi, ed.), pp. 234-278. Dekker, New York.
- Shoshan, V., and Selman, B. R. (1979). *J. Biol. Chem.* **254**, 8801-8807.
- Shoshan, V., and Selman, B. R. (1980). *J. Biol. Chem.* **255**, 384-389.
- Shoshan, V., and Strotmann, H. (1980). *J. Biol. Chem.* **254**, 996-999.
- Shoshan, V., Shavit, N., and Chipman, D. M. (1978). *Biochim. Biophys. Acta* **504**, 108-122.
- Sigrist-Nelson, K., and Azzi, A. (1979). *J. Biol. Chem.* **254**, 4470-4474.
- Sigrist-Nelson, K., Sigrist, H., and Azzi, A. (1978). *Eur. J. Biochem.* **92**, 9-14.
- Skye, G. E., Shavit, N., and Boyer, P. D. (1967). *Biochem. Biophys. Res. Commun.* **28**, 724-729.
- Slater, E. C. (1977). *Annu. Rev. Biochem.* **46**, 1015-1025.
- Smith, D. J., Stokes, B. O., and Boyer, P. D. (1976). *J. Biol. Chem.* **251**, 4165-4171.
- Smith, J. B., and Wilkonski, C. (1978). *Fed. Proc., Fed., Am. Soc. Exp. Biol.* **37**, 1521 (abstr.).
- Strotmann, H., and Bickel-Sandkötter, S. (1977). *Biochim. Biophys. Acta* **400**, 126-135.
- Strotmann, H., Hesse, H., and Edelman, K. (1973). *Biochim. Biophys. Acta* **314**, 202-210.
- Strotmann, H., Bickel-Sandkötter, S., and Shoshan, V. (1979). *FEBS Lett.* **101**, 316-320.
- Sugiyama, Y., and Mukohata, Y. (1978). *FEBS Lett.* **85**, 211-214.
- Sugiyama, Y., and Mukohata, Y. (1979a). *FEBS Lett.* **98**, 276-280.
- Sugiyama, Y., and Mukohata, Y. (1979b). In "Cation Flux across Biomembranes" (Y. Mukohata and L. Packer, eds.), pp. 261-273. Academic Press, New York.
- Tiefert, M. A., and Moudrianakis, E. N. (1979). *J. Biol. Chem.* **254**, 9500-9508.
- Tiefert, M. A., Roy, H., and Moudrianakis, E. N. (1977). *Biochemistry* **16**, 2396-2404.
- Vallejos, R. H., Ravizzini, R. A., and Andreo, C. S. (1977). *Biochim. Biophys. Acta* **459**, 20-26.
- Vambutas, B. K., and Bertsch, W. (1976). *Biochem. Biophys. Res. Commun.* **76**, 686-693.
- Vambutas, V. K., and Racker, E. (1965). *J. Biol. Chem.* **240**, 2660-2667.
- VanderMeulen, D. L., and Govindjee (1977). *Eur. J. Biochem.* **78**, 585-598.
- Vinkler, C., Rosen, G., and Boyer, P. D. (1978). *J. Biol. Chem.* **253**, 2507-2510.
- von Stedingk, L.-V., and Baltscheffsky, H. (1966). *Arch. Biochem. Biophys.* **117**, 400-413.
- Webster, G. D., and Jackson, J. B. (1978). *Biochim. Biophys. Acta* **503**, 135-154.
- Webster, G. D., Edwards, P. A., and Jackson, J. B. (1977). *FEBS Lett.* **76**, 29-35.
- Weiss, M. A., and McCarty, R. E. (1977). *J. Biol. Chem.* **252**, 8007-8012.

- Winget, G. D., Kanner, N., and Racker, E. (1977). *Biochim. Biophys. Acta* **460**, 490–502.
- Witt, H. T. (1975). In "Bioenergetics of Photosynthesis" (Govindjee, ed.), pp. 493–554. Academic Press, New York.
- Yoshida, M., Sone, N., Hirata, H., Kagawa, Y., and Ui, N. (1979). *J. Biol. Chem.* **254**, 9525–9533.
- Younis, H., Winget, G. D., and Racker, E. (1977). *J. Biol. Chem.* **252**, 1814–1818.

Part VI

Biosynthesis of Pigments

Biosynthesis of Pigments in Plants and Bacteria

CONSTANTIN A. REBEIZ*
JUNE LASCELLES

I. Introduction.....	702
II. Detection, Putative Structure, and Distribution of Chemically Different Chlorophyll <i>a</i> and <i>b</i> Species in Green Plants.....	703
A. Contributions of the Degradative-Synthetic Approach to the Elucidation of the Structure of Chlorophyll.....	703
B. The Biosynthetic Approach and Its Contribution to the Elucidation of the Structure of Chlorophyll.....	707
C. Detection of Novel Chlorophyll <i>a</i> and <i>b</i> Chromophores in Green Plants.....	709
D. Stability and Reactivity of the Different Chlorophyll <i>a</i> Chromophoric Species.....	713
E. Distribution of the Various Chlorophyll Chromophores among the Subchloroplast Constituents of the Thylakoid Membranes.....	714
F. Relationship of the Chlorophyll Chromophores Described in This Work to the Spectral Chlorophyll Species Described by Earlier Workers.....	717
G. Putative Structure of the Various Chlorophyll <i>a</i> Chemical Species That Occur in Green Plants.....	718
III. Structure, Distribution, and Function of Bacterial Tetrapyrroles.....	721
A. Bacteriochlorophylls.....	721
B. Hemes.....	721
C. Corrinoids.....	724
D. Phycobilins.....	724
IV. Formation of the Chlorophyll <i>a</i> Pool in Green Plants.....	725
A. Formation and Subsequent Metabolism of the Divinyl and Monovinyl Chlorophyll <i>a</i> Pools.....	726
B. Formation and Subsequent Metabolism of the Divinyl and Monovinyl Chlorophyllide <i>a</i> Pools.....	728
C. Structure and Formation of the Divinyl and Monovinyl Protochlorophyll Pools in Green Plants.....	730
D. Metabolic Intermediates between Mg-Protoporphyrin Monoester and the Protochlorophyllide <i>a</i> Pools.....	740
E. Structure and Formation of the Mg-Protoporphyrin Monoester Pool.....	742
F. Structure and Formation of the Mg-Protoporphyrin Diester Pool.....	745
G. Structure and Formation of the Mg-Protoporphyrin Pool.....	746
H. Structure and Formation of the Protoporphyrin Pool.....	748

*The work in this chapter was supported by NSF grant PCM #78-11559 to C. A. Rebeiz.

I.	Biosynthesis of Protoporphyrinogen IX.....	751
J.	Biosynthesis of Coproporphyrinogen III.....	752
K.	Biosynthesis of Uroporphyrinogen III.....	752
L.	Biosynthesis of Porphobilinogen.....	753
M.	Formation of δ -Aminolevulinic Acid.....	753
V.	Formation of the Chlorophyll <i>b</i> Pool in Green Plants.....	756
VI.	Regulation of the Chlorophyll Biosynthetic Pathway.....	757
VII.	Synthesis of Hemes and Bacteriochlorophyll in Photosynthetic Bacteria	759
A.	Biosynthesis of δ -Aminolevulinic Acid.....	759
B.	Biosynthetic Reactions between δ -Aminolevulinic Acid and Protoporphyrin.....	761
C.	Formation of Iron Porphyrins.....	763
D.	Formation of Bacteriochlorophyll.....	764
VIII.	Regulation of Bacteriochlorophyll Synthesis.....	767
A.	Interaction of the Iron and Magnesium Branches of the Biosynthetic Pathway.....	768
B.	Coupling of Bacteriochlorophyll Synthesis with Protein and Lipid Synthesis.....	769
C.	Effects of Oxygen and Light Intensity.....	769
IX.	Synthesis of Phycobilins.....	770
X.	Formation of Prenylipids (Including Carotenoids).....	771
	References.....	772

ABBREVIATIONS

ALA	δ -Aminolevulinic acid
BChl	Bacteriochlorophyll
Chl	Chlorophyll
Chl a_1	Chl <i>a</i> complex of PSI
Chl a_{II}	Chl <i>a</i> complex of PSII
Chlide	Chlorophyllide
Chl(ide)	A mixture of Chl + Chlide
Copro	Coproporphyrin III
Coprogen	Coproporphyrinogen III
Cyt	Cytochrome
DOVA	γ,δ -dioxovaleric acid
DV	Divinyl
ESR	Electron spin (paramagnetic) resonance
GSSG	Oxidized glutathione
Harderogen	Harderoporphyrinogen
HQNO	2-Heptyl-4-hydroxyquinoline <i>N</i> -oxide
ICM	Intracytoplasmic membrane
LDAO	Lauryldimethylamine <i>N</i> -oxide
LH	Light harvesting
LHC	Light-harvesting Chl-protein complex
LW	Long wavelength
LWMP	longer wavelength metalloporphyrins

Mg-Proto	Mg-protoporphyrin
Meso Proto	Mesoporphyrin
MPE	Mg-protoporphyrin monoester
MV	Monovinyl
MW	Molecular weight
NMR	Nuclear magnetic resonance
nt	Nonphototransformable
PBC	Porphobilinogen
Pchl	Protochlorophyll
Pchl-H	Pchl holochrome
Pchl _{id}	Protochlorophyllide
Proto	Protoporphyrin
Protogen	Protoporphyrinogen
Pyal P	Pyridoxal phosphate
RC	Reaction center
<i>Rp.</i>	<i>Rhodospseudomonas</i>
<i>Rs.</i>	<i>Rhodospirillum</i>
SDS	Sodium dodecyl sulfate
SW	Short wavelength
t	Phototransformable
Uro	Uroporphyrin III
Urogen	Uroporphyrinogen III

ABSTRACT

Evidence for the occurrence of multiple chlorophyll (Chl) chemical species in green plants is discussed, and the differential distribution of these chlorophyll species among the structural-functional entities of the thylakoid membrane is described. The origin of the multiple Chl *a* chromophoric species is traced back to divinyl and monovinyl Chl(ide) *a*, respectively. The biosynthetic pathway that gives rise to the divinyl and monovinyl Chl_{id} *a* species is depicted as a four-branched pathway. The divinyl and monovinyl biosynthetic branches seem to originate either from coproporphyrinogen III (Coprogen) or from protoporphyrinogen IX (Protogen). Further down the pathway, at the level of Mg-protoporphyrin (Mg-Proto), each of the monovinyl and divinyl biosynthetic branches is considered to split into esterified and unesterified subbranches. The two esterified subbranches give rise to divinyl and monovinyl Chl *a*, whereas the two unesterified subbranches give rise to divinyl and monovinyl Chl_{id} *a*.

The photosynthetic prokaryotes including cyanobacteria show versatility in their capacity to form a variety of tetrapyrrole structures. These are derived from δ -aminolevulinic acid (ALA), and in the *Rhodospirillaceae* ALA synthase is apparently the enzyme responsible for ALA formation. The C₅ dicarboxylic path of ALA formation is found in higher plants, and it may also be a major route in cyanobacteria. Only fragmentary information is available about the steps from protoporphyrin to bacteriochlorophyll (BChl), based mainly upon pyrroles accumulated by various mutants. The biosynthesis of BChl appears to be closely integrated with the formation of the intracytoplasmic membrane system of which the proteins associated with the antenna and reaction center BChl constitute a major proportion. A deeper understanding of the regulation of BChl synthesis and of its incorporation into the photosynthetic membranes requires knowledge at the enzymic level.

I. Introduction

The conversion of light energy into chemical energy during photosynthesis is a multistep phenomenon. It involves (a) the absorption of light by antenna Chl* and accessory pigments, (b) the transfer of the absorbed light quanta to special structural-functional sites, i.e., to reaction centers (RC), and (c) the conversion of light energy into electronic-chemical energy in the RCs (Govindjee and Govindjee, 1975). Although several chemically different BChl chromophores† are known to occur in the different groups of bacteria (e.g., Section III,A), it has been assumed that all green plants synthesize and accumulate only one Chl *a* and one Chl *b* chemical species (Fischer and Stern, 1940; Woodward, 1961). This has led to the conclusion that in green plants the various photochemical steps involved in the capture of solar energy and its conversion into electronic energy are catalyzed only by one Chl *a* chemical species with or without the cooperation of one Chl *b* chemical species (Govindjee and Govindjee, 1975). In order to reconcile the putative singleness of the Chl *a* chemical structure with its multiple functional roles, it has been suggested that the catalytic role of Chl is defined only by its specific association with the lipoproteins of its macromolecular environment and/or by its specific association with other Chl molecules (Anderson, 1975; Fong, 1975; Thornber, 1975; Brown, 1977; Katz *et al.*, 1978). In photosynthetic bacteria, the association of BChl with bacteriopheophytin, for example, seems to account for some of the RC catalytic activities (Fajer and Davis, 1980; also see Okamura *et al.*, Chapter 5, and Parson and Ke, Chapter 8, this volume).

However, recent investigations of the Chl biosynthetic pathway have generated a substantial body of experimental evidence that cannot be reconciled with the notion that green plants synthesize and accumulate only one Chl *a* and one Chl *b* chemical species. Indeed, recent biosynthetic and analytical results suggest that several, chemically different Chl *a*

*The term *chlorophyll* is used here generically to designate chlorophyll molecules that may differ from one another by the nature of their side chain substituents at positions 2 and 4 of the macrocycle. For example, monovinyl chlorophyll is defined here as that chlorophyll with a vinyl group at position 2 (or 4) of the macrocycle and an ethyl group at position 4 (or 2) of the macrocycle. Divinyl chlorophyll refers to a chlorophyll molecule with vinyl groups at both the 2 and 4 positions of the macrocycle. The same terminology is used for chlorophyllide, protochlorophyll, protochlorophyllide, protochlorophyllide ester, Mg-protoporphyrin monoester, Mg-protoporphyrin, and protoporphyrin.

†The term *chromophore* refers to the tetrapyrrole moiety of the tetrapyrrole-protein complexes encountered in plants.

and Chl *b* chromophores are formed and are incorporated into the photosynthetic membranes during greening (Bélanger and Rebeiz, 1979; Rebeiz *et al.*, 1980). In addition to unraveling an unsuspected complexity in the Chl biosynthetic pathway, this discovery has raised new questions concerning the relationship between the biosynthesis of the novel Chls, their chemical structure, and their possible function. For example, recent results suggest that (a) the different Chl species probably perform different functions in photosynthesis (Freyssinet *et al.*, 1980); and that (b) the structure of the various Chl chromophores may be dictated by the interaction of the nascent chlorophyllide chromophores with the lipoproteins of the thylakoid membranes during the terminal steps of Chl biosynthesis (Bélanger and Rebeiz, 1980b). The understanding of the absorption, transfer, and conversion of light energy into electronic energy by the photosynthetic membranes may therefore depend among other things on a thorough understanding of the chemical structure of the different Chl chromophores. This in turn may depend on the understanding of the Chl biosynthetic pathway and on its relationship to the molecular architecture of the macromolecular environment where the final steps of Chl biosynthesis take place.

It is the purpose of this chapter to familiarize the students of photosynthesis with the biochemistry of photosynthetic pigment formation so that they may gain a better understanding of the structure and function of the plant pigments that catalyze the photosynthetic process.

II. Detection, Putative Structure, and Distribution of Chemically Different Chlorophyll *a* and *b* Species in Green Plants

During the past 70 years, two systematic approaches have been applied to the elucidation of the structure of Chl: (a) the degradative-synthetic approach and (b) the biosynthetic approach. These will be briefly reviewed before undertaking the discussion of the Chl biosynthetic pathway.

A. Contributions of the Degradative-Synthetic Approach to the Elucidation of the Structure of Chlorophyll

The systematic study of the structure and chemistry of Chl *a* and *b* was initiated by Willstätter and co-workers early in this century (Willstätter and Stoll, 1913). They described the gross properties of Chl and of

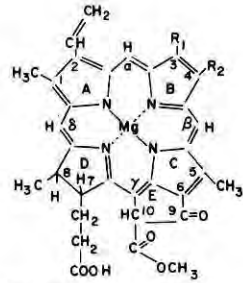
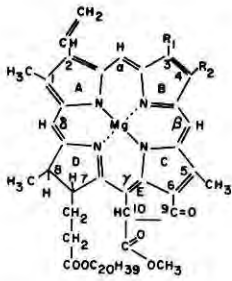

I. CHLOROPHYLLS

- (a) $R_1 = -CH_3$; $R_2 = -CH=CH_2$; *DV* CHL *a*
 (b) $R_1 = -CH_3$; $R_2 = -CH_2-CH_3$; *MV* CHL *a*
 (c) $R_1 = -CHO$; $R_2 = -CH=CH_2$; *DV* CHL *b*
 (d) $R_1 = -CHO$; $R_2 = -CH_2-CH_3$; *MV* CHL *b*

II. CHLOROPHYLLIDES

- (a) $R_1 = -CH_3$; $R_2 = -CH=CH_2$; *DV* CHLIDE *a*
 (b) $R_1 = -CH_3$; $R_2 = -CH_2-CH_3$; *MV* CHLIDE *a*
 (c) $R_1 = -CHO$; $R_2 = -CH=CH_2$; *DV* CHLIDE *b*
 (d) $R_1 = -CHO$; $R_2 = -CH_2-CH_3$; *MV* CHLIDE *b*

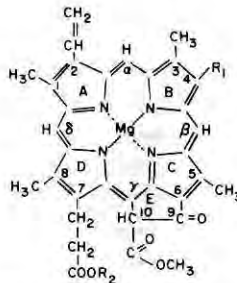

III. PROTOCHLOROPHYLL POOL

- (a) $R_1 = -CH=CH_2$; $R_2 = -C_{20}H_{33}$; *DV* PCHLIDE ESTER
 (b) $R_1 = -CH_2-CH_3$; $R_2 = -C_{20}H_{33}$; *MV* PCHLIDE ESTER
 (c) $R_1 = -CH=CH_2$; $R_2 = H$; *DV* PCHLIDE
 (d) $R_1 = -CH_2-CH_3$; $R_2 = H$; *MV* PCHLIDE

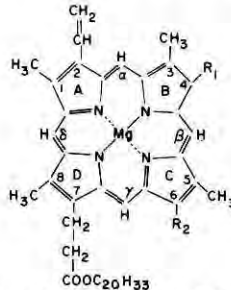

IV. INTERMEDIATES BETWEEN Mg-PROTO DIESTER AND PCHLIDE ESTER

- (a) $R_1 = -CH=CH_2$; $R_2 = -CH=CH-COO-CH_3$; *DV* ACRYLATE DIESTER
 (b) $R_1 = -CH_2-CH_3$; $R_2 = -CH=CH-COO-CH_3$; *MV* ACRYLATE DIESTER
 (c) $R_1 = -CH=CH_2$; $R_2 = -CHOH-CH_2-COO-CH_3$; *DV* HYDROXYPROPIONATE DIESTER
 (d) $R_1 = -CH_2-CH_3$; $R_2 = -CHOH-CH_2-COO-CH_3$; *MV* HYDROXYPROPIONATE DIESTER
 (e) $R_1 = -CH=CH_2$; $R_2 = -CO-CH_2-COO-CH_3$; *DV* KETOPROPIONATE DIESTER
 (f) $R_1 = -CH=CH_2$; $R_2 = -CO-CH_2-COO-CH_3$; *MV* KETOPROPIONATE DIESTER

FIG. 1. Some putative intermediates of the Chl biosynthetic pathway.

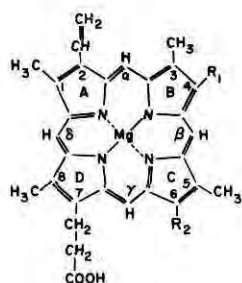

V. INTERMEDIATES BETWEEN MPE AND PCHLIDE

- (a) $R_1 = -CH=CH_2$; $R_2 = -CH=CH-COO-CH_3$; *DV* ACRYLATE MONOESTER
 (b) $R_1 = -CH_2-CH_3$; $R_2 = -CH=CH-COO-CH_3$; *MV* ACRYLATE MONOESTER
 (c) $R_1 = -CH=CH_2$; $R_2 = -CHOH-CH_2-COO-CH_3$; *DV* HYDROXYPROPIONATE MONOESTER
 (d) $R_1 = -CH_2-CH_3$; $R_2 = -CHOH-CH_2-COO-CH_3$; *MV* HYDROXYPROPIONATE MONOESTER
 (e) $R_1 = -CH=CH_2$; $R_2 = -CO-CH_2-COO-CH_3$; *DV* KETOPROPIONATE MONOESTER
 (f) $R_1 = -CH-CH_2$; $R_2 = -CO-CH_2-COO-CH_3$; *MV* KETOPROPIONATE MONOESTER

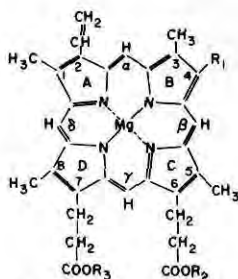

VI. Mg-PROTO DIESTER, MPE AND Mg-PROTO POOLS

- (a) $R_1 = -CH=CH_2$; $R_2 = -CH_3$; $R_3 = -C_{20}H_{33}$; = *DV* Mg-PROTO DIESTER
 (b) $R_1 = -CH_2-CH_3$; $R_2 = -CH_3$; $R_3 = -C_{20}H_{33}$; = *MV* Mg-PROTO DIESTER
 (c) $R_1 = -CH=CH_2$; $R_2 = -CH_3$; $R_3 = H$; = *DV* MPE
 (d) $R_1 = -CH_2-CH_3$; $R_2 = -CH_3$; $R_3 = H$; = *MV* MPE
 (e) $R_1 = -CH=CH_2$; $R_2 = H$; $R_3 = H$; = *DV* Mg-PROTO
 (f) $R_1 = -CH_2-CH_3$; $R_2 = H$; $R_3 = H$; = *MV* Mg-PROTO

FIG. 1. (Cont.)

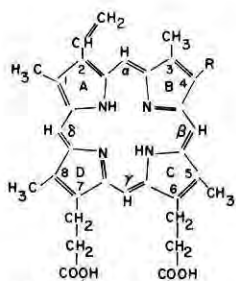

VII. PROTOPORPHYRIN POOL
 (a) $R = -CH=CH_2$; *DV* PROTO
 (b) $R = -CH_2-CH_3$; *MV* PROTO

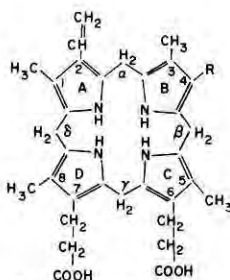

VIII. PROTOPORPHYRINOGEN POOL
 (a) $R = -CH=CH_2$; *DV* PROTOGEN
 (b) $R = -CH_2-CH_3$; *MV* PROTOGEN

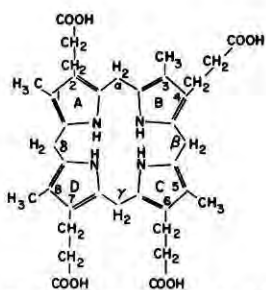

IX. COPROPORPHYRINOGEN III

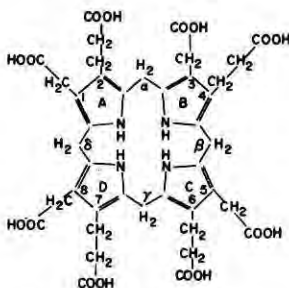

X. UROPORPHYRINOGEN III

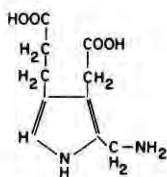

XI. PORPHOBILINOGEN

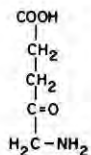

XII. δ -AMINOLEVULINIC ACID

FIG. 1. (Cont.)

many of its degradation products. Later on, a more thorough understanding of the fine structure of Chl was made possible by the research of Fischer and his group (Fischer and Orth, 1937; Fischer and Stern, 1940). With an admirable sense of deduction and with systematic synthesis and analysis of the structure of the Chl degradation products described earlier by Willstätter and Stoll (1913), Fischer and co-workers proposed structural formulas for Chl *a* (Fig. 1, 1b) and *b* (Fig. 1, 1d) (Fischer and Stern, 1935; Fischer and Wenderoth, 1939). The chemistry, photochemistry, electronic structure, and function of Chl *a* and *b* are essentially based on these structures and on additional stereochemical details described by others, namely, (a) that the methyl and propionic ester groups in ring *D* are *trans* (Ficken *et al.*, 1956); (b) that the phtyl group is 2'-*trans*-7'*R*:11'*R* (Burrell *et al.*, 1966); (c) that the relative configuration at carbon 10 is such that the methoxycarbonyl group is *trans* to the C₇ propionic ester side chain (Wolf *et al.*, 1967; Katz *et al.*, 1968); and (d) that the absolute configuration of the macrocycle was determined by conventional chemical correlation with (-)- α -santonin (Fleming, 1968).

The degradative-synthetic approach reached its climax with the work of Woodward and co-workers (1960; Woodward, 1960, 1961), who synthesized a chlorin-*e*₆ trimethyl ester chromophore, which was shown to be identical in its melting point and quantitative visible and infrared spectra to an authentic sample of chlorin-*e*₆ trimethyl ester (Fig. 2,f) prepared from natural Chl *a*. Since the synthetic steps from Chlorin-*e*₆ to Chl *a* had been described earlier (Willstätter and Stoll, 1911; Willstätter and Forsén, 1913; Fischer and Löwenberg, 1929; Stoll and Wiedemann, 1952), the synthesis of Chlorin-*e*₆ by Woodward *et al.* (1960) was taken as proof for the accuracy of the Chl *a* structural formula (Fig. 1, 1b), which was proposed by Fischer and Stern (1940).

B. The Biosynthetic Approach and Its Contribution to the Elucidation of the Structure of Chlorophyll

The degradative-synthetic approach adopted by Fischer and by Woodward was not complemented, however, by biosynthetic studies, that is by studies of how Chl is actually assembled in nature. To put it differently, since Chl is assembled in the chloroplast according to a very rigorous sequence of reactions and since its final structure is the end product of all the concerted biochemical reactions of the Chl biosynthetic chain, it is reasonable to expect that the structure of Chl as deduced from degradative-synthetic investigations should be compatible with the

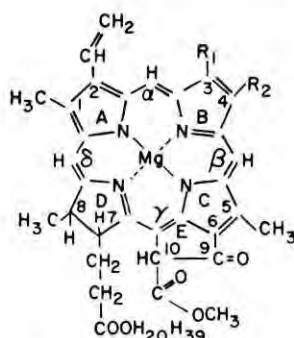

(a) $R_1 = -CH_3$; $R_2 =$ AS LISTED IN TABLE II; CHL *a*

(b) $R_1 = -CHO$; $R_2 =$ AS LISTED IN TABLE II; CHL *b*

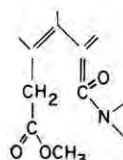
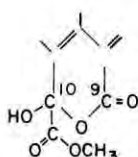
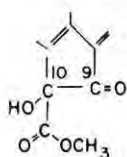

(c) 10 HYDROXY CHL; (d) 10 HYDROXY CHL LACTONE; (e) $R_1 = CH_3$;

CHLORIN-6-AMIDE

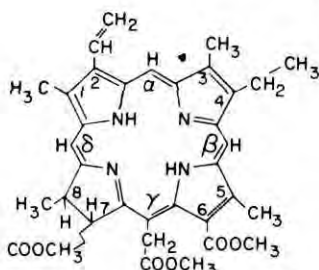

(f) CHLORIN-e₆ TRIMETHYL ESTER

FIG. 2. Some derivatives of Chl.

sum total of the biochemical reactions that are supposed to give rise to that same structure.

In the past decade, several developments have had a significant impact on our understanding of the Chl biosynthetic pathway and on the concomitant understanding of the fine structure of the unaltered Chl *a*

and *b* pools of green plants, namely (a) advances in analytical instrumentation such as spectrofluorometry and high pressure liquid chromatography; (b) availability of increasingly fast computational facilities; and (c) availability of cell-free systems that have enabled the stepwise study of almost all the biosynthetic steps between Proto IX and Chl *a* (Rebeiz and Castelfranco, 1971a, b, 1973; Rebeiz *et al.*, 1975a, b, c, 1978). These developments have in turn made possible the detection of novel metabolic intermediates between Coprogen III and Chl *a* and *b* in etiolated, greening, and green plant tissues as well as in algal cells (see the following section). The conversion of these intermediates into several Chls that appear to differ spectroscopically and chemically from one another will be discussed at length.

C. Detection of Novel Chlorophyll *a* and *b* Chromophores in Green Plants

1. THE ROLE OF ANALYTICAL FLUORESCENCE TECHNIQUES IN THE DETECTION OF NOVEL CHLOROPHYLL CHROMOPHORES

The use of fluorescence emission and excitation spectrofluorometry has been instrumental in the detection and spectral characterization of the multiple Chl chromophores. It is, therefore, appropriate to precede the description of the various Chl chromophores by a brief introduction to the spectrofluorometric techniques that were used in this work. In addition to its high sensitivity (pmole quantities of tetrapyrroles are readily detectable), fluorescence measurements are highly selective. For example, in a mixture containing several fluorescent species having approximately equal relative fluorescence quantum yield but having different absorption and emission properties, it is possible in most cases to elicit the fluorescence of any compound in the mixture by exciting the mixture at the wavelength of maximum absorption of the compound being sought. Of course the other compounds in the mixture may also fluoresce depending on their molar extinction coefficient at that particular excitation wavelength. Conversely the absorption–excitation spectrum of any one of the compounds in the mixture may also be observed by recording an excitation spectrum (also referred to as an action spectrum) at the wavelength of maximum emission of the compound of interest. Furthermore, if the fluorescence measurements are made at 77°K, a significant narrowing of the emission and excitation bands is observed. This in turn engenders a considerable improvement in the resolution of these bands. These facts are illustrated in Fig. 3, for a

mixture containing about 3 parts of Chl *b* for 97 parts of Chl *a* in ether. When the pigment mixture was excited at 440 nm, i.e., near the Soret absorption maximum of Chl *a*, only a Chl *a* emission maximum at 674 nm was elicited. On the other hand, upon exciting the mixture near the Soret absorption maximum of Chl *b*, i.e., at 470 nm, a distinct Chl *b* emission maximum at 660 nm was elicited in addition to the Chl *a* emission maximum at 674 nm (Fig. 3). An absorption spectrum of this Chl mixture, recorded on a spectrophotometer, will only reveal the presence of Chl *a*.

2. THE USE OF MATRIX TECHNIQUES IN THE DETECTION OF NOVEL CHLOROPHYLL SPECIES AND OF THEIR PRECURSORS

In order to determine the minimum number of fluorescent species in the various metabolic pools of the Chl biosynthetic pathway extensive use was made of Weber's matrix technique (Weber, 1961; Rebeiz *et al.*, 1980).

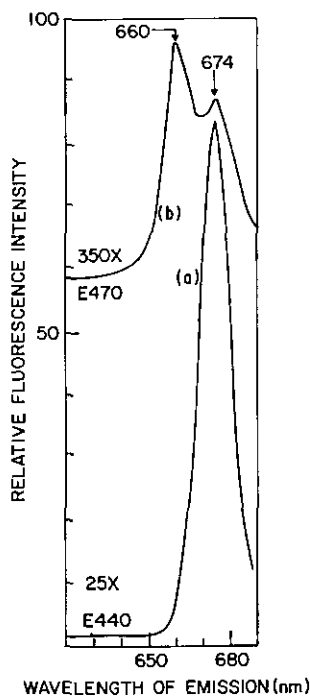

FIG. 3. Fluorescence emission spectra of a Chl extract containing 97 units of Chl *a* for every 3 units of Chl *b*, in ether at 77°K. (a) Chl *a* emission band with a maximum at 674 nm, elicited by a 440-nm excitation; (b) Chl *b* emission band with a maximum at 660 nm elicited by a 470-nm excitation. Excitation bandwidth = 6 nm; emission bandwidth = 3 nm. Ordinate scale attenuation is indicated on the spectra, 350 × being the least attenuation possible. Baselines were arbitrarily adjusted to avoid overlap of the spectra. Arrows point to wavelengths of interest. (From Freyssinet *et al.*, 1980.)

3. DETECTION OF DIFFERENT CHLOROPHYLL *a* AND *b* CHROMOPHORES

When investigating the conversion of newly discovered divinyl (*DV*) protochlorophylls* (PChls) into Chls, it was observed that both *DV* and monovinyl (*MV*) PChls were converted by light into *DV* and *MV* Chl *a* and Chlide *a* species (Bélanger and Rebeiz, 1980b; Duggan and Rebeiz, 1982b). After extraction in acetone and transfer to diethyl ether, the various *DV* and *MV* Chl *a* and Chlide *a* chromophoric species exhibited different fluorescence properties than the Chl *a* and Chlide *a* chromophoric species extracted from mature green tissues. The newly formed *DV* and *MV* Chl *a* and Chlide *a* species were eventually converted during the course of greening into various Chl *a* chromophoric species of undetermined structure (Bélanger and Rebeiz, 1980b). These observations led Rebeiz and co-workers to investigate systematically the Chl *a* and *b* pools of green mature cells and plant tissues; during the course of these investigations, the chemical heterogeneity of the Chl *a* and *b* pools of green plants became apparent.

At the present time, the different Chl *a* and *b* chromophores that populate the Chl *a* and *b* pools of green plants are most conveniently detected by their Soret excitation maxima in ether at 77°K. The latter were found to be different for the various Chl species (Rebeiz *et al.*, 1980). The minimum number of the Chl species was determined by extensive analysis of 10 × 10 emission-excitation matrix constructs (Rebeiz *et al.*, 1980).

In addition to small amounts of *DV* Chl *a* (E458F673) (about 1% or less of the total Chl *a*) four additional spectral species of Chl *a* appear to populate the Chl *a* pool of green plants. The latter are referred to as Chl *a* (E432F664), Chl *a* (E436F670), Chl *a* (E443F672), and Chl *a* (E446F674), where E refers to the Soret excitation maxima and F refers to the fluorescence emission maxima in ether at 77°K (Rebeiz *et al.*, 1980). At times, Chl *a* (E432F664) + Chl *a* (E436F670) are referred to collectively as short wavelength (SW) Chls, whereas Chl *a* (E443F672) + Chl *a* (E446F674) are referred to as long wavelength (LW) Chls. All these Chl *a* species have been detected in extracts of various green tissues, and some were partially purified by high-pressure liquid chromatography on a silica gel column (Fig. 4) (Rebeiz *et al.*, 1980). They were also detected by difference spectrofluorometry at room temperature, in ether solutions of the Chl *a* pool (Fig. 5).

*Protochlorophyll refers to the mixture of protochlorophyllide and protochlorophyllide ester found in plant tissues.

FIG. 4. Fluorescence emission (A) and excitation (B) spectra in ether at 77°K of the four Chl *a* chromophores separated by high-pressure liquid chromatography from an acetone extract of a green spinach leaf. The emission spectra were elicited by the E wavelength indicated. The excitation spectra were recorded at the F wavelength indicated. All other conditions and symbols are as in Fig. 3. (From Rebeiz *et al.*, 1980.)

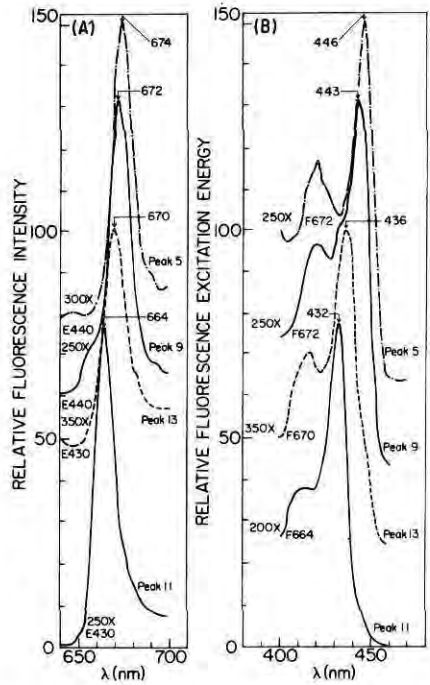
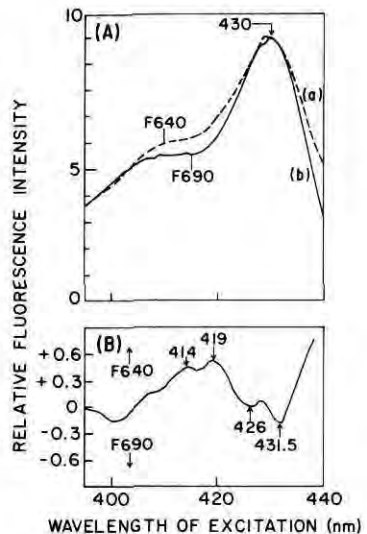

FIG. 5. Detection of the four Chl *a* chromophoric species by difference spectrofluorometry in ether at room temperature. Two Soret excitation spectra (a and b) were recorded on a spectrofluorometer equipped with dual excitation holographic gratings and interfaced with a microcomputer. The two excitation spectra were recorded at the short wavelength and long wavelength tails (i.e., at F640 nm and F690 nm, respectively) of the Chl *a* red emission band in ether at room temperature. Each excitation spectrum was the sum of 10 repetitive scans. The two excitation spectra (a and b) were normalized to the same value at their Soret excitation maxima, and then the computer generated the difference spectrum F640–F690, depicted in (B). The spectra were recorded at an emission bandwidth of 2 nm and an excitation bandwidth of 1 nm. All symbols are as in Fig. 3. (From C. A. Rebeiz, unpublished.)



of the Chl *a* chromophores of green plants under a variety of mild experimental conditions commonly used in the extraction and purification of Chl in the laboratory. The investigation dealt with the Chl *a* pool, since the latter is considered to be more labile than the Chl *b* pool (Seely, 1966). None of the following treatments had any detectable effect on the spectrofluorometric profile of the extracted Chl *a* pool: (a) extraction of the chloroplast membranes with alkaline or slightly acidified (pH 6.8) acetone; (b) extraction of chloroplast membranes in alkaline ethanol; (c) excessive dilution of the extracted Chl with acetone or ether; (d) lipid content of the medium from which the Chl is extracted; (e) storage of isolated chloroplasts at 77°K for 2 weeks; (f) solubilization of chloroplast membranes with nonionic (digitonin, Triton X-100), or ionic (SDS) detergents; and (g) exposure of green tissues to alternating light–dark cycles. Altogether these results were interpreted by Rebeiz *et al.* (1981) as an indication that the Chl chromophoric species (a) were not artifacts of allomerization, since the spectrofluorometric profile of the Chl *a* pool remained the same irrespective of the pH of the extraction medium (Seely, 1966), (b) were not artifacts of acetone extraction, since the same results were obtained by extraction with ethanol, and (c) were not aggregation artifacts, since extensive dilution with ether did not alter the spectrofluorometric profile of the different Chl *a* chromophoric species.

E. *Distribution of the Various Chlorophyll Chromophores among the Subchloroplast Constituents of the Thylakoid Membranes*

It is relevant to inquire whether the various Chl species which were just described are equally distributed among the functional components of the thylakoid membrane. This in turn would give some indication as to whether these Chl chromophores have different functions in photosynthesis.

This question was investigated by Freyssinet *et al.* (1980). Thylakoid membranes were solubilized with Triton-X100 and were segregated by polyacrylamide SDS gel electrophoresis into six Chl–protein complexes and one free-pigment band. The pigment–proteins conventionally associated with the RCs of the Chl *a*_I (CP88) and Chl *a*_{II} (CP43 and CP41) complexes were found to be highly enriched in SW Chl *a*, whereas the light-harvesting Chl–protein complex (LHC) and the antenna Chl fraction of the Chl *a*_I complex were highly enriched in LW Chl *a* species (Fig. 7, Table I). Likewise subchloroplast particles enriched in the reaction centers of the Chl *a*_I and Chl *a*_{II} complexes and in the LHC were

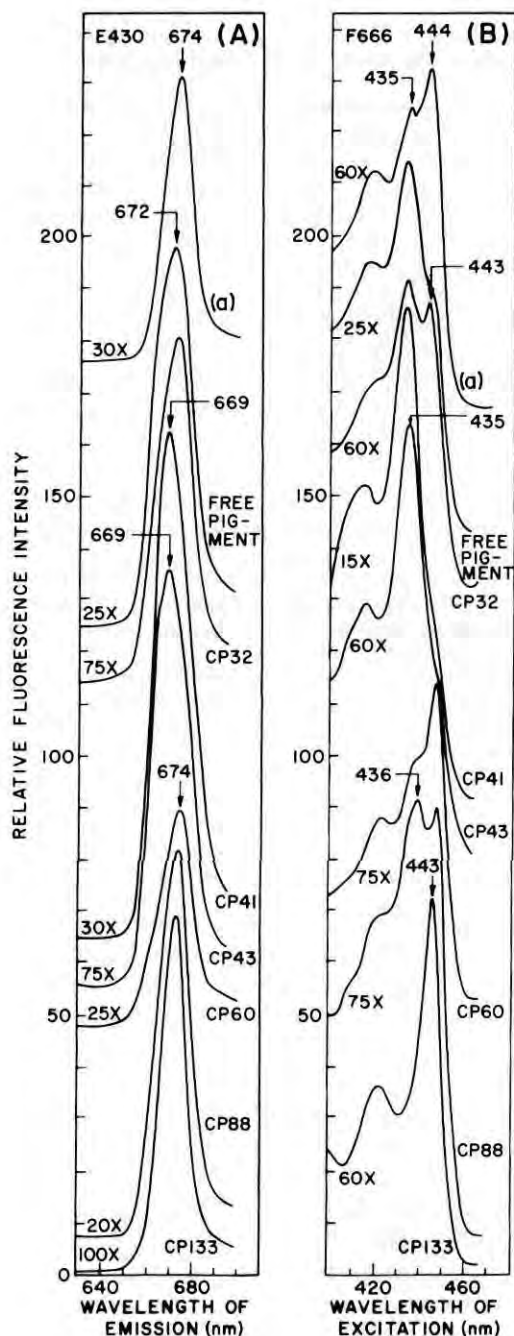

FIG. 7. Fluorescence emission and excitation spectra in ether at 77°K of the Chl *a* pool extracted from the different Chl-protein complexes listed in Table I and from lysed chloroplast membranes. The various Chl-proteins (CP) are designated by their relative molecular weight in kilodaltons. (a) The Chl *a* pool from lysed chloroplast membranes was purified on thin layers of celluloses. (A) Emission spectra elicited by an excitation E at 430 nm, in order to enhance the emission of the SW Chl *a* species. (B) Soret excitation spectra recorded at an emission wavelength of 666 nm in order to emphasize the contribution of the SW Chl *a* to the Soret excitation profile. All other conditions and symbols are as in Fig. 3. (From G. Freyssinet and C. A. Rebeiz, unpublished data.)

TABLE I

Distribution of the Chlorophyll *a* Chromophores among the Various Green Pigment Bands Separated by Electrophoresis^a

Band number	Pigment or pigment-protein complex	Chl <i>a</i> species (%) ^b				Chl <i>a</i> ratio LW/SW ^c
		E432 F664	E436 F670	E443 F672	E446 F674	
1	CP133 ^d	0.1(1.1)	0.1(0.8)	6.2(47.2)	6.7(50.9)	64.5
2	CP88	2.0(12)	3.9(23.2)	4.2(25.2)	6.6(39.7)	1.8
3	CP60	1.7(8.1)	2.9(13.7)	4.7(22.3)	11.9(55.9)	3.6
4	CP43	0.8(22.0)	2.0(55.2)	0.4(10.3)	0.5(12.4)	0.3
5	CP41	1.1(21.3)	3.2(60.3)	0.4(7.3)	0.6(11.2)	0.2
6	CP32	1.4(12.8)	2.7(24.4)	2.0(17.9)	4.9(44.8)	1.7
7	Free pigment	6.1(20.4)	11.8(39.5)	2.5(8.4)	9.5(31.8)	0.7
Sum of bands 1-7		13.2	26.6	20.4	40.7	1.5
Purified Chl <i>a</i> pool ^e		8.8	26.3	23.8	41.0	1.8

^aThe pigment-protein bands were separated by SDS-polyacrylamide gel electrophoresis. The Chl was extracted in acetone then transferred to ether for spectrofluorometric monitoring at 77°K. Results are expressed in percent of the total amount of Chl *a* present in the seven green bands. Numbers in parenthesis refer to the percentage of a particular Chl species in a particular band, normalized to 100. (From G. Freyssinet and C. A. Rebeiz, unpublished work.)

^bThese percentages are at best very rough estimates, since the quantum yield of fluorescence of the different Chl species is still unknown (Freyssinet *et al.*, 1980) and since no effort was made to correct for the contribution of the MV Chl *a* monosolvate fluorescence to the fluorescence of the Chl *a* (E432F664), (E436F670), and (E443F672) species (Bélanger and Rebeiz, 1981). Furthermore, the possible occurrence of DV Chl *a* in the various pigment-protein complexes was not evaluated.

^cLW Chl = (E446 F674) + (E443 F672); SW Chl = (E436 F670) + (E432 F664).

^dCP 133 refers to a Chl-protein band with a MW of 133, 000, etc.

^eThe Chl *a* pool was purified on thin layers of cellulose.

prepared by conventional techniques, and the Chl was extracted, transferred to ether, and monitored spectrofluorometrically at 77°K. It was observed that the Chl *a*_I and Chl *a*_{II} preparations were enriched in SW Chl *a*, whereas the LHC was enriched in LW Chl *a* (Freyssinet *et al.*, 1980).

Surprisingly, Chl *b* chromophoric species were also detected in all the pigment-protein preparations and in the Chl *a*_I and Chl *a*_{II} complexes. In the latter and in CP88, CP43, and CP41 they occurred, in very small amounts and their detection was only made possible by the high resolution of the fluorescence technique that was used. This observation led Freyssinet *et al.* (1980) to wonder whether the Chl *b* chromophores detected in the Chl *a*_I and Chl *a*_{II} complexes were constitutive components of the RCs or were due instead to mere contamination by the LHC.

*F. Relationship of the Chlorophyll Chromophores**Described in This Work to the Spectral Chlorophyll Species**Described by Earlier Workers*

Various Chl spectral forms were observed in the past when solutions of Chl in organic solvents were monitored spectroscopically at low temperatures. The interpretation of these Chl species was subject however to continuous reevaluation as the understanding of the chemistry of the Chl molecule improved with time (Evstigneev *et al.*, 1949; Freed and Sancier, 1951, 1952, 1954; Livingston and Weil, 1952; Singhal *et al.*, 1968).

In all the preceding work, the Chl spectral forms, detectable at 77°K in organic solvents, were attributed to one Chl chromophoric species that coordinated with one or two solvent molecules at 77°K to form pentacoordinated (monosolvate) and hexacoordinated (disolvate) Chl *a* species. In our opinion, the two Chl spectral species detected by Freed and Sancier (1952) and further described by Singhal *et al.* (1968) are probably identical to two of the several Chl species reported by Rebeiz *et al.* (1980). Although the fluorescence of the MV Chl *a* monosolvate component of the Chl *a* pool does contribute to the fluorescence of some of the Chl *a* [(E432F664), (E436F670) and (E443F672)] species (Bélanger and Rebeiz, 1981), the Chl species reported by Rebeiz *et al.* (1980) and by Bélanger and Rebeiz (1980b) cannot be accounted for solely by the formation of MV Chl *a* monosolvates and disolvates or to the freezing-out and aggregation of the pigments at 77°K for the following reasons:

1. The multiple Chl *a* chromophoric species were detected in ether solutions, at room temperature by difference spectrofluorometry (Fig. 5).
2. In the 10^{-6} M and lower concentration range, within which all the determinations at 77°K were made, the Chl Soret excitation profile was independent of pigment concentration.
3. Upon removing the central Mg atom from Chl, the resulting pheophytins also exhibit a heterogeneous profile in ether at 77°K.
4. Some of the different Chl *a* species were partially purified and separated by HPLC (Rebeiz *et al.*, 1980).
5. The Chl *a* pool extracted from greening tissues was shown to be populated by widely different proportions of the various Chl species, depending on the stage of greening of the tissue (e.g., Section IV,A,B) and on the pigment-protein source from which the Chl *a* pool was extracted (e.g., Section II,E). Were the different

Chl *a* chromophoric species due only to the formation of different Chl *a* solvates or to other artifacts, then the same Chl *a* artifacts should have been observed irrespective of the stage of greening or of the source from which the Chl *a* pool was prepared.

6. Finally and maybe most importantly, the metabolic precursors of the multiple Chl chromophores have been detected and partially purified from several etiolated tissues (e.g., Section IV).

A significant portion of this chapter will actually deal with the biochemical interconversions of these Chl precursors.

G. *Putative Structure of the Various Chlorophyll a Chemical Species That Occur in Green Plants*

It is self-evident that the elucidation of the chemical structure of the aforementioned Chl species is an essential prerequisite for a full understanding of their function in photosynthesis. Although the exact chemical structure of these Chls is still unknown, enough information is already available to justify speculation about their possible chemical structure.

Four potential sites of chemical modification of the Chl molecule are presently envisioned. The first two sites may well be positions 2 and 4 of the Chl macrocycle (Fig. 1, I). Indeed, it now appears that most of the Chl *a* chromophores are derived from DV Chlide *a* (Section VI) (Duggan and Rebeiz, 1982b). For example, by considering that vinyl side chains can be reduced to ethyl groups or can be oxidized to hydroxyethyl groups and by taking into account that these reactions can take place either at position 2 or at position 4 of the macrocycle (Fig. 1, I), as well as at both positions simultaneously, one is led to a total of six chemically different Chl *a* and six possible Chl *b* chromophores (Table II) (Rebeiz *et al.*, 1980). It is also obvious from Table II that three of the six Chl species namely the monoethyl, monohydroxy ethyl Chls, the monovinyl, monoethyl Chls, and the monovinyl, monohydroxy ethyl Chls can occur as geometrical isomers (Rebeiz *et al.*, 1980). Of course, conversion of the substituents at position 2 and 4 of the macrocycle into formyl, acetyl, or other groups is another possibility. It has become evident however that Chl *a* species with different substituents, at position 2 and 4 of the macrocycle, than conventional MV Chl *a* (Table II) can only account for a very small amount of the total Chl *a* pool. For example, it now appears that probably only about 1% or less of the total Chl *a* pool of green plants is made up of DV Chl *a* (Fig. 1, Ia) whereas 80–90% of

TABLE II

Proposed Structure of Some of the Different Chlorophyll *a* and *b* Chromophores of Higher Plants^a

Proposed name of the Chl <i>a</i> or Chl <i>b</i> chromophore	Substituents at positions 2 or 4 of the macrocycle	
	Position 2	Position 4
2,4-Diethyl-Chl	—CH ₂ —CH ₃	—CH ₂ —CH ₃
2,4-Divinyl-Chl	—CH=CH ₂ OH 	—CH=CH ₂ OH
2,4-Monohydroxyethyl-Chl	—CH—CH ₃	—CH—CH ₃
2-Vinyl-4-ethyl-Chl ^b or 2-Ethyl-4-vinyl-Chl ^b	—CH=CH ₂	—CH ₂ —CH ₃
2-Monohydroxyethyl-4-ethyl-Chl ^b or 2-ethyl-4-monohydroxyethyl-Chl ^b	—CH ₂ —CH ₃ OH 	—CH—CH ₃
2-Monohydroxyethyl-4-vinyl-Chl ^b or 2-Vinyl-4-monohydroxyethyl-Chl ^b	—CH—CH ₃	—CH=CH ₂ OH
	—CH=CH ₂	—CH—CH ₃

^aIt is assumed that some of the modifications reside in the side-chain substitutions at the 2 and 4 positions of otherwise conventional Chl *a* and *b* chromophores. (From Rebeiz *et al.*, 1980.)

^bThese chromophore pairs are geometrical isomers.

that pool consists of MV Chl *a* (E446F674) (Fig. 1, Ib). Some plant mutants, however, (maize ON8147) seem to accumulate mainly DV Chl *a* (Bazzaz, 1981). Small amounts of other 2,4-substituted Chl *a* species (Table II) may conceivably occur in green plants but their presence has not yet been established. The balance of the Chl *a* pool appears to consist of Chl *a* (E432F664), which exhibits the spectroscopic properties of a 10-OH-Chl *a* lactone (Fig. 2d) and of Chl *a* (E436F670) and of Chl *a* (E443F672), the structures of which remain to be determined.

A third potential site of chemical modification of the Chl macrocycle may be at the cyclopentanone ring. This was suggested from a study of the conversion of red-shifted DV and MV Chlide *a* into SW Chl *a* species (Section IV, B). During the course of this study, it was observed that the

blue shift that accompanied the conversion of newly formed DV and MV Chlide *a* into SW Chl *a* chromophores was somewhat similar to the blue shift observed during the conversion of Chl *a* into 10-OH-Chl *a* lactone (Fig. 2d) (Hochapfel *et al.*, 1970) but was different from the shift that accompanied the conversion of Chl *a* into chlorin 6-amide (Fig. 2e) (Pennington *et al.*, 1967).

A fourth potential site of chemical modification of the Chl *a* molecule became evident when it was observed that the small amounts of DV and MV Chl *a*, which are produced from the Pchlido ester pool by a brief light treatment, have a different long-chain alcohol at position 7 of the macrocycle than phytol (Section IV,A,1,b).

Finally it may be relevant to ponder the reason why the different Chl chromophoric species of green plants went so far undetected by powerful spectroscopic techniques such as mass spectroscopy, as well as NMR and infrared spectroscopy. Actually field desorption mass spectra of pheophytin *a* and *b* and of Chl *a* and *b* do exhibit multiple profiles (Evans *et al.*, 1975; Jackson, 1977) that cannot be accounted for by Mg and ¹³C natural abundance peaks but that may well correspond to the Chl chromophoric species described in this chapter. On the basis of oxidation potentials and second-moment ESR line widths, it has been proposed (Wasielwski *et al.*, 1981) that the primary electron donor in PSI of plants may be a monomeric Chl *a* enol instead of a dimer made up of two MV Chl *a* components as suggested by Katz *et al.* (1978). Chl *a* enols are unstable chemical species and have been proposed as intermediates in the epimerization, pyrochlorophyll formation, solvolysis, alomerization, and 10-OH-Chl *a* lactone formation in organic solvents (Seely, 1966; Hynninen, 1979). It can be readily conceived that an endogenous Chl *a* enol could be stabilized by the lipoprotein components of the thylakoid membranes, but could be readily converted into a 10-OH-Chl *a* lactone during extraction with organic solvents. The enrichment of RC preparations with SW Chl *a* (E432 F664), which exhibit spectral properties very similar to those of synthetic 10-OH-Chl *a* lactone, has already been mentioned (Section II,E and G).

Altogether it is easy to visualize how infrared and NMR spectral profiles of mixtures of the Chl *a* chromophores may reflect the structure of the most abundant chromophore, i.e., Chl *a* (E446F674), whereas subtle structural differences pertaining to the remaining three Chl *a* chromophoric species may be swamped and go undetected. It is hoped that future NMR, infrared, and mass spectroscopic studies of the individual Chl *a* and *b* chromophoric species may yield valuable information about the structure of these Chls.

III. Structure, Distribution, and Function of Bacterial Tetrapyrroles

Considered as a group, the photosynthetic prokaryotes show great versatility in their ability to make tetrapyrrole structures. In addition to the Chls, they form a variety of hemes, vitamin B₁₂ derivatives, and in the cyanobacteria, linear tetrapyrroles related to mammalian bile pigments. The present evidence indicates that these various pigments arise from a common biosynthetic pathway derived from δ -aminolevulinic acid (ALA).

A. Bacteriochlorophylls

Bacteriochlorophylls (BChl) are the predominant type of tetrapyrrole made by photosynthetic bacteria and several varieties of structure have been identified (Pfennig, 1978; Fig. 8). The most well-known form, BChl *a*, is found in Rhodospirillaceae; BChl *b* has so far been identified only in *Rp. viridis*. BChls *c*, *d*, and *e* are found in the green sulfur bacteria (Chlorobiaceae). It is not possible to make firm statements about the distribution of the various forms of pigment among the different groups of bacteria. Relatively few species have been examined in the thorough detail required to assign a particular structure or to establish the presence of only one type of pigment. For example, BChl *a* is apparently in the RC of green sulfur bacteria (Olson, 1978), and this pigment (and BChl *c*) is found in the filamentous green bacteria (Pierson and Castenholz, 1978). Another variable is the hydrocarbon component; the more usual phytyl residue may be replaced by farnesyl.

B. Hemes

Photosynthetic bacteria are rich in soluble and membrane-bound *c*-type cytochromes, (Cyt) and many also contain forms of Cyt *b* (Bartsch, 1978). Cyt *a* is more rare and has been found so far in aerobically grown *Rp. sphaeroides* (Saunders and Jones, 1974). The presence of these various types of cytochrome imply the ability to synthesize the component heme structure (Fig. 9). Green plants also contain a *c*-type cytochrome (Cyt *f*) and several *b*-type cytochromes. These are discussed by Cramer and Crofts, Chapter 9, this volume.

In addition to hemes *a*, *b*, and *c*, the novel siroheme (Fig. 9d) has been recently found in *Chromatium vinosum* (Schedel *et al.*, 1979). This octacarboxylic heme was originally identified as the prosthetic group of the

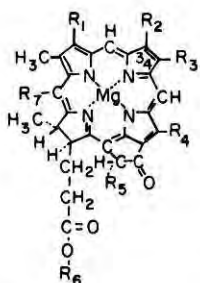

Pigment	R ₁	R ₂	R ₃	R ₄	R ₅	R ₆	R ₇
Chlorophyll <i>a</i> ^a	-CH=CH ₃	-CH ₃	-CH ₂ -CH ₃	-CH ₃	-C(=O)-O-CH ₃	P	-H
Chlorophyll <i>b</i> ^a	-CH=CH ₃	-C(=O)-H	-CH ₂ -CH ₃	-CH ₃	-C(=O)-O-CH ₃	P	-H
Bacteriochlorophyll <i>a</i>	-C(=O)-CH ₃	-CH ₃ ^b	-CH ₂ -CH ₃ ^b	-CH ₃	-C(=O)-O-CH ₃	P/Gg	-H
Bacteriochlorophyll <i>b</i>	-C(=O)-CH ₃	-CH ₃ ^c	=C-CH ₃ ^c H	-CH ₃	-C(=O)-O-CH ₃	P	-H
Bacteriochlorophyll <i>c</i>	H -C-CH ₃ OH	-CH ₃	-C ₂ H ₅ -C ₃ H ₇ i-C ₄ H ₉	-C ₂ H ₅ -CH ₃ (?)	-H	F	-CH ₃
Bacteriochlorophyll <i>d</i>	H -C-CH ₃ OH	-CH ₃	-C ₂ H ₅ -C ₃ H ₇ i-C ₄ H ₉	-C ₂ H ₅ -CH ₃ (?)	-H	F	-H
Bacteriochlorophyll <i>e</i>	H -C-CH ₃ OH	-C(=O)-H	-C ₂ H ₅ -C ₃ H ₇ i-C ₄ H ₉	-C ₂ H ₅	-H	F	-CH ₃

FIG. 8. Structure of Chls and BChls. (From Gloe *et al.*, 1975.)

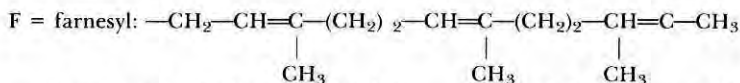
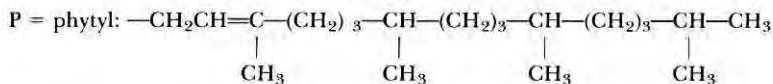

^aMore specifically, 2-vinyl-4-ethyl-Chl.
 additional H-atoms at positions C-3 and C-4.

^bNo double bond between C-3 and C-4;
^cNo double bond between C-3 and C-4; an additional H-atom in position C-3.

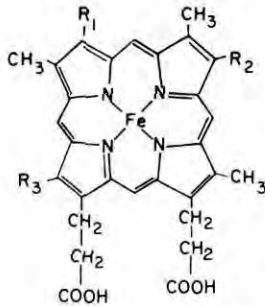

(a) $R_1, R_2 = -CH=CH_2; R_3 = -CH_3$; = PROTOHEME

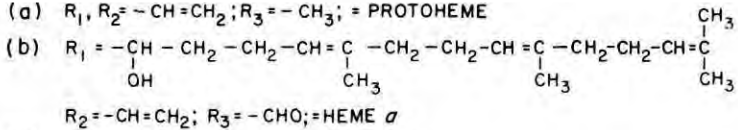

(c) $R_1, R_2 = -\underset{\text{S}}{\text{CH}} - \text{CH}_3; R_3 = -CH_3$; = HEME ϵ
 PROTEIN

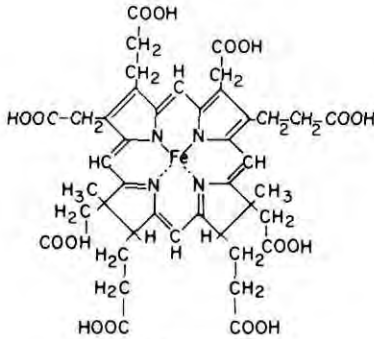

(d) SIROHEME

FIG. 9. Hemes found in photosynthetic bacteria.

assimilatory sulfite reductase of *Escherichia coli* (Murphy and Siegel, 1973) and has since been shown to be the component heme of a variety of sulfite reductases and also of assimilatory nitrite reductases from microorganisms and plants (Murphy *et al.*, 1974; Hucklesby *et al.*, 1978). In *Chromatium*, siroheme is associated with the sulfite reductase from cells grown photoautotrophically with sulfide. It is not detectable in photoheterotrophic cells grown with sulfate as source of sulfur. Thus,

the question of whether siroheme is the prosthetic group of the assimilatory sulfite reductases of the photosynthetic bacteria remains open.

C. Corrinoids

Derivatives of vitamin B₁₂ (corrinoids) are widely distributed in the photosynthetic bacteria, but little is known of their biosynthesis; a major function of this group of factors is its involvement in methionine synthesis (Lascelles, 1978).

D. Phycobilins

The characteristic blue-green color of the cyanobacteria is attributable to the phycobiliproteins with linear open-chain tetrapyrroles as chromophore. The prosthetic group is covalently bonded to the protein and the complexes may comprise up to 60% of the total soluble protein of the cells (Bogorad, 1975). Certain eukaryotic algae (*Rhodophyta* and *Cryptophyta*) also contain phycobiliproteins, which function as LH pigments. The structures of the two major chromophores—phycoyanobilin and phycoerythrin—are similar to the mammalian bile pigments, which arise from degradation of heme (Fig. 10).

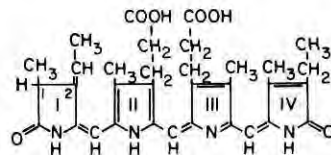

(a) PHYCOCYANOBILIN

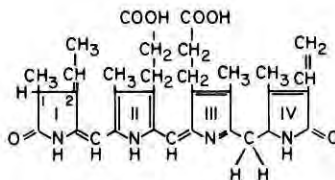

(b) PHYCOERYTHROBILIN

FIG. 10. Phycobilins.

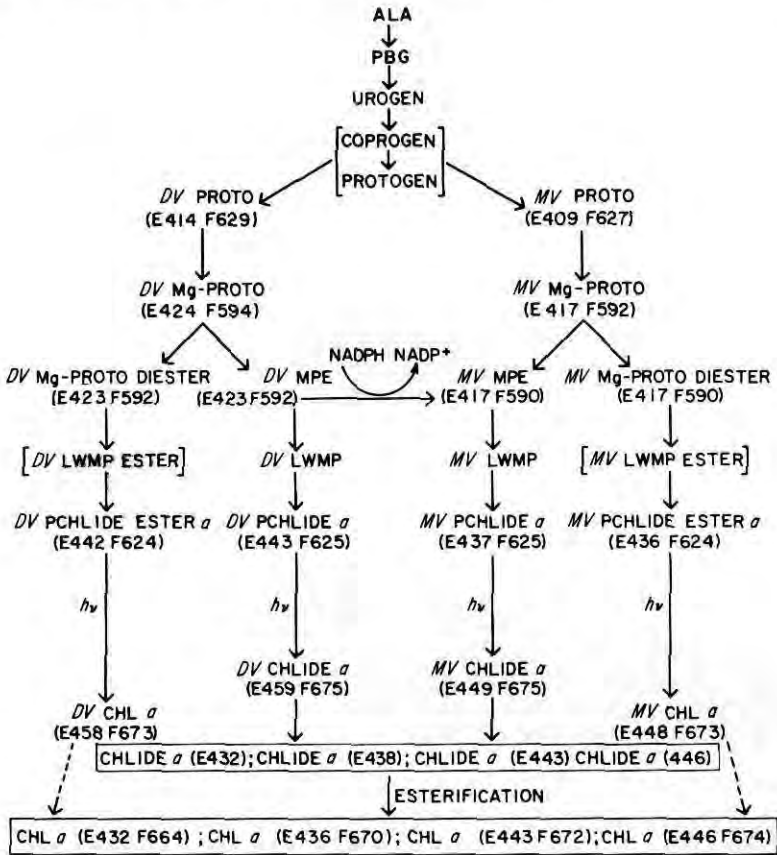

FIG. 11. Proposed pathway of Chl *a* biosynthesis. E and F refer to the Soret excitation and fluorescence emission maxima, respectively, of the various tetrapyrroles in ether at 77°K. The Proto pool was monitored in pyridine. Dashed arrows point to uncertain reactions. Bracketed compounds refer to postulated but still undetected intermediates. (From Rebeiz *et al.*, 1981.)

IV. Formation of the Chlorophyll *a* Pool in Green Plants

Enough experimental evidence is already available to propose a tentative pathway that may account for the formation of multiple Chl *a* species in green plants. Such a pathway is depicted in Fig. 11. It consists of two main branches that originate either in the Coprogen III or in the

Protogen IX pools and that we propose to designate as the MV and DV biosynthetic branches. These branches are in turn subdivided into two subbranches that appear to originate in the MV and DV Mg-protoporphyrin (Mg-Proto) pools, respectively. We propose to designate these biosynthetic subbranches as the fully esterified and acidic subbranches of the Chl biosynthetic pathway, respectively (Fig. 11). The four subbranches are considered to give rise, in turn, to multiple Chl *a* chromophores. The experimental evidence for such a pathway is discussed later.

A. Formation and Subsequent Metabolism of the Divinyl and Monovinyl Chlorophyll *a* Pools

Upon illuminating an etiolated tissue containing Pchlde (III, c and d; Fig. 1) and Pchlde ester (III, a and b; Fig. 1) protein complexes, with white actinic light for about 47 msec to 2 sec, most of the Pchlde pool is photoreduced into Chlide *a*, whereas about 4–6% of the Pchlde ester pool is converted into Chl *a*. In both cases, it is believed that the photoreduction involves the addition of two transhydrogens at the 7–8 positions of the macrocycle (III; Fig. 1) (Rebeiz and Castelfranco, 1973).

1. PHOTOCVERSION OF DIVINYL AND MONOVINYL PROTOCHLOROPHYLLIDE ESTER INTO DIVINYL CHLOROPHYLL α (E458F673) AND MONOVINYL CHLOROPHYLL α (E448F673)

It was observed by Bélanger and Rebeiz (1980b) that both the DV and MV components of the Pchlde ester pool of etiolated tissues were photoconverted by a brief light treatment into two different Chl *a* chromophores having an emission maximum at 673 nm and Soret excitation maxima at 458 nm and 448 nm, respectively, in ether at 77°K (Fig. 12 b and c). The two Chl *a* thus produced were identified with the first stable photoproducts of DV and MV Pchlde ester photoreduction. They were designated DV Chl *a* (E458F673) and MV Chl *a* (E448F673). Since the fatty alcohol of the Pchlde ester pool is not phytol (Liljenberg, 1974; McCarthy *et al.*, 1981), it follows that the esterifying alcohol in the DV and MV Chl *a*, which are formed from the DV and MV Pchlde ester pools by photoreduction, is not phytol either.

2. METABOLISM OF DIVINYL AND MONOVINYL CHLOROPHYLL α

At the present time, it is not clear whether the newly formed DV Chl *a* (E458F673) and MV Chl *a* (E448F673) are converted into the LW Chl *a* [Chl *a* (E446F674), Chl *a* (E443F672)], and SW Chl *a* [Chl *a* (E436F670),

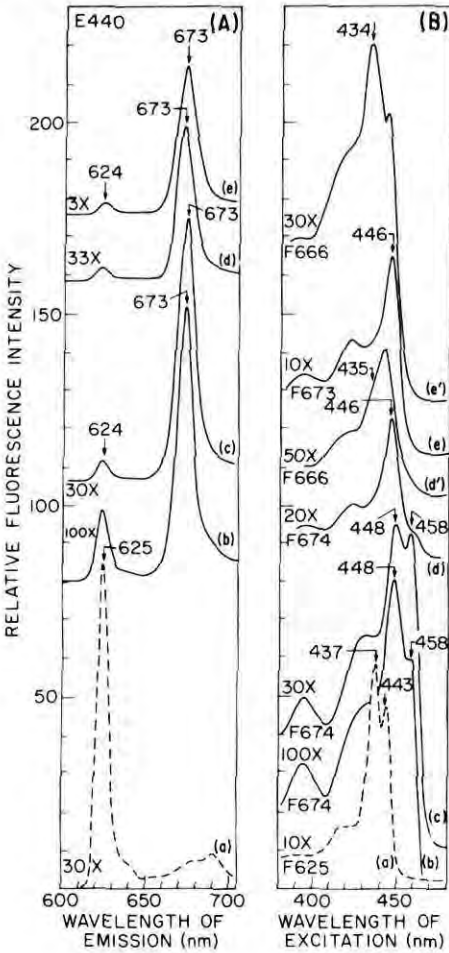

FIG. 12. Fluorescence emission (A) and excitation (B) spectra in ether at 77°K of the Chl *a* pool extracted from etiolated cucumber cotyledons after various light treatments. The emission and excitation spectra were recorded at the excitation E and emission F wavelengths indicated on the spectra. (a) Pchl *a* ester pool of etiolated tissue, (b) Chl *a* pool after 47 msec of illumination, (c) Chl *a* pool after 2 sec of illumination, (d,d') Chl *a* pool after 30 sec of illumination, (e,e') Chl *a* pool after 2 sec of illumination and 5 min of dark incubation. All other symbols and conditions are as in Fig. 3. (From Bélanger and Rebeiz, 1980b.)

Chl *a* (E432F664)] encountered in mature green tissues or whether they remain as minor components of the Chl *a* pool of green tissues (Fig. 11). This uncertainty is based on the observations that (a) the DV and MV Chl *a* chromophores, which are formed from the Pchl *a* ester pool by a brief light treatment amount only to about 0.5–1% of the total Chl *a* pool formed during the same illumination and (b) when the newly formed Chl *a* pool is converted into various Chl *a* chromophores by esterification it obscures the fate of the small amount of DV and MV Chl *a* formed from Pchl *a* ester. This is well illustrated in Fig. 12e and e', when after 2 sec of illumination followed by 5 min of dark incubation, the DV and MV Chl *a* species formed from Pchl *a* ester by photoreduc-

tion were no longer detectable, as the Chl *a* pool was swamped by the complete conversion of the Chlide *a* pool into LW and SW Chl *a* species (Bélanger and Rebeiz, 1980b).

B. Formation and Subsequent Metabolism of the Divinyl and Monovinyl Chlorophyllide a Pools

There is little doubt that the bulk of the Chl *a* pool is a by-product of the light metabolism of the Pchlde pool. This appears to be the case in etiolated tissues exposed to light as well as in plant tissues grown under natural dark-light conditions (Cohen *et al.*, 1977; Cohen and Rebeiz, 1978). It is also well accepted that when Pchlde chromophores, which are properly associated with apoproteins, are illuminated with light of the proper wavelength, most of the Pchlde is converted into Chlide *a* by addition of two trans-hydrogens across the 7-8 carbons of the macrocycle (II and III; Fig. 1). This important step of the Chl biosynthetic pathway has been extensively reviewed during the past 30 years (Rebeiz and Castelfranco, 1973).

Recently, it has become apparent that the Pchlde pool of etiolated and greening tissues was actually more complex than was previously realized (e.g., Section IV,C) and was shown to consist mainly of DV Pchlde (E443F625) and MV Pchlde (E437F625) instead of MV Pchlde only as was previously assumed (Bélanger and Rebeiz, 1980a). It now appears that both the DV and MV Pchlde pools are independently photoconverted by light into two different Chlide *a* which in turn are converted into different Chl *a* chromophoric species by esterification (Bélanger and Rebeiz, 1980b).

1. PHOTOCONVERSION OF DIVINYL AND MONOVINYL PROTOCHLOROPHYLLIDE INTO DIVINYL CHLOROPHYLLIDE *a* (E459F675) AND MONOVINYL CHLOROPHYLLIDE *a* (E449F675)

The first photoproducts of DV and MV Pchlde photoconversion by a short light treatment (47 msec to 2 sec of actinic white light) were shown by Bélanger and Rebeiz (1980b) to consist of two different Chlide *a* chromophores with an emission maximum at 675 nm and Soret excitation maxima at 459 nm and 449 nm, respectively, in ether at 77°K (Fig. 13, A, B, b and c). By analogy to the DV and MV Chl *a* produced from the photoreduction of DV and MV Pchlde ester (see earlier), the newly formed Chlide *a* species were designated DV Chlide *a* (E459F675) and MV Chlide *a* (E449F675) (Fig. 13, A, B, b, and c). Duggan and Rebeiz (1982b) subsequently demonstrated the specific precursor-product rela-

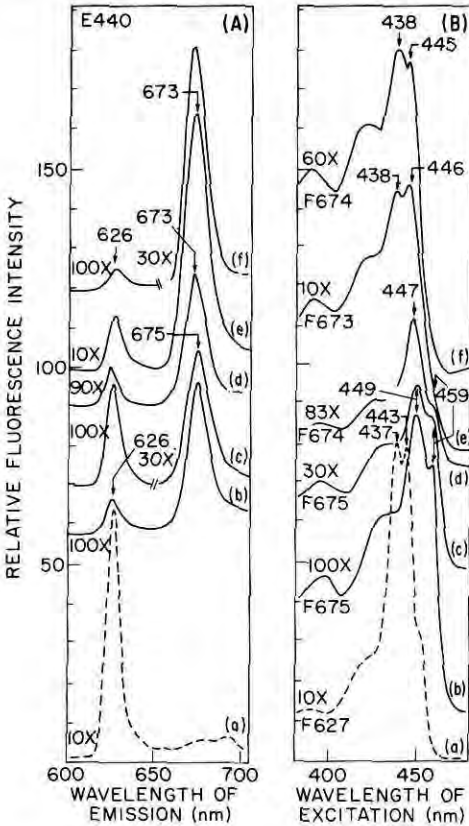

FIG. 13. Fluorescence emission (A) and excitation (B) spectra in ether at 77°K of the Pchl *a* and Chl *a* pools extracted from etiolated cucumber cotyledons after various light treatments. The emission and excitation spectra were recorded at the excitation E and emission F wavelengths indicated on the spectra. (a) Pchl *a* pool of etiolated tissue, (b) Chl *a* pool after 47 msec of illumination, (c) Chl *a* pool after 2 sec of illumination, (d) Chl *a* pool after 30 sec of illumination, (e) Chl *a* pool after 1 min of illumination, (f) Chl *a* pool after 5 min of illumination. All other symbols and conditions are as in Fig. 3. (From Bélanger and Rebeiz, 1980b.)

tionship between DV Pchl *a* and its photoproduct, Chl *a* (E459F675), whereas Bélanger *et al.* (1982) demonstrated the DV nature of this Chl *a* (E459F675) species by extensive chemical derivatization. It is still not clear however, whether one or two different photoenzymes are involved in the photoreduction of DV and MV Pchl *a*. The further metabolism of the newly formed Chl *a* intermediates is discussed in the following section.

2. METABOLISM OF DIVINYL AND MONOVINYL CHLOROPHYLLIDE *a*

It now appears that DV and MV Chl *a* are transient intermediates with a very short lifetime (Bélanger and Rebeiz, 1980b). They appear to be rapidly converted into LW and SW Chl *a* chromophores, which are subsequently converted by esterification into LW and SW Chl *a* (Figs. 11–13). More recent results also indicate that a fraction of the DV Chl *a*

a is converted into MV Chlide *a* (Duggan and Rebeiz, 1982) while a smaller fraction is converted, by esterification, into DV Chl *a* (E458F673) (S. M. Wu and C. A. Rebeiz, 1982). As was noted earlier (Section II,G), small amounts of DV Chl *a* appear to be a permanent constituent of the Chl *a* pool of green plants. Finally it has been reported that the conversion of Chlide *a* into Chl *a* proceeds first by esterification of the Chlide *a* with geranylgeraniol; the latter is then converted into phytol by a stepwise reduction (Schoch *et al.*, 1977). The relationship of the esterification reactions to the conversion of DV Chlide *a* and of LW and SW Chlide *a* species to DV Chl *a* and to LW and SW Chl *a* chromophores has not yet been investigated.

3. RELATIONSHIP BETWEEN THE FORMATION OF DIFFERENT CHL(IDE) *a* CHROMOPHORIC SPECIES AND THE DIFFERENT SPECTRAL SHIFTS OBSERVED IN SITU

Following the initial photoreduction of the Pchl-apoprotein complexes of etiolated tissues into Chl(ide) *a*-protein complexes, the latter undergo a distinct pattern of spectral shifts in situ as a function of postillumination time. These in situ spectral shifts have been thoroughly investigated (Thorne, 1971) and have been reviewed at length (Kirk, 1970; Rebeiz and Castelfranco, 1973). For example the following spectral shifts have been described in etiolated bean leaves, as the newly formed Chlide *a* proteins are converted into various Chl *a*-protein species (Thorne, 1971): Pchl (E650F655) → Intermediate (E668F674) → Chlide *a* (E678F687) → Chlide *a* (E682F694) → Chl *a* (E672F680).

In the past, these *in situ* shifts have been invariably attributed to different associations of single Chl(ide) *a* chemical species with their macromolecular environment and/or with other similar Chl(ide) *a* chemical species. In view of the observed chemical multiplicity of the Chlide *a* and Chl *a* chromophoric pools, it stands to reason to propose that the in situ spectral shifts of the newly formed Chl(ide) *a*-proteins may also reflect the formation of different Chlide *a* and Chl *a* chemical species, since they interact with their macromolecular environment during the process of becoming integrated into the thylakoid membranes (Bélanger and Rebeiz, 1980b).

C. Structure and Formation of the Divinyl and Monovinyl Protochlorophyll Pools in Green Plants

The Pchl pool is the precursor of the Chl *a* pool (Sections IV,A and B) in green plants. Originally the Pchl pool was thought to consist exclusively of Pchl ester, i.e., of a Pchl ester, which was esterified with a

long-chain alcohol at the seventh position of the macrocycle (III,b; Fig. 1) (Koski and Smith, 1948). In 1950, however, Granick (1950b) demonstrated the accumulation of a Pchl-like compound in an X-ray mutant of *Chlorella vulgaris*, and he determined that it was a Mg-vinyl pheoporphyrin *a* 5, i.e., a MV Pchl_{id}e that lacked an esterifying alcohol at position 7 of the macrocycle (III,d; Fig. 1). On the basis of the structural similarities of Pchl_{id}e and Pchl_{id}e ester, Granick (1950b) proposed that Pchl_{id}e was probably the immediate precursor of Pchl_{id}e ester and is, therefore, a legitimate intermediate of the Chl biosynthetic pathway in plants. Loeffler (1955) detected the presence of Pchl_{id}e in higher plant tissues, but the central role of Pchl_{id}e as the major precursor of the Chl *a* pool in green plants was not recognized until 1957. At that time Wolff and Price (1957) demonstrated that the immediate precursor of most of the Chl *a* in higher plants was not Pchl_{id}e ester but was instead Chl_{id}e *a*, which was formed from Pchl_{id}e by photoreduction. At that point, Pchl_{id}e ester was no longer considered to be a precursor of Chl *a*, and most students of the greening process considered it to be a by-product of Pchl_{id}e metabolism, having an ill-defined function.

In the past decade, three main developments helped change the preceding picture, namely, (a) the demonstration of the phototransformability of Pchl_{id}e ester (Rebeiz and Castelfranco, 1973; Rebeiz *et al.*, 1978; Bélanger and Rebeiz, 1980b); (b) the realization that Pchl_{id}e ester was not formed from Pchl_{id}e by esterification but that both Pchl_{id}e and Pchl_{id}e ester were formed in parallel from a common precursor (Rebeiz *et al.*, 1970), which in turn led Rebeiz *et al.* (1970, 1978) to propose that the Chl *a* biosynthetic pathway was not a single-branched pathway as was previously believed (Granick and Mauzerall, 1961; Bogorad, 1966; Battersby and McDonald, 1975) but was a branched pathway, which was divided into two parallel branches, namely, a fully esterified branch and an acidic branch; and finally (c) it was established that both the Pchl_{id}e and Pchl_{id}e ester pools were each made up of MV and DV chromophoric species (Bélanger and Rebeiz, 1979, 1980a, b, c). Therefore in the ensuing sections, the biosynthesis of the Pchl_{id}e ester and of the Pchl_{id}e pools will be examined separately.

1. STRUCTURE AND FORMATION OF THE PROTOCHLOROPHYLLIDE POOL

a. Structure of the Protochlorophyllide Pool. The Pchl_{id}e pool is membrane-bound and is localized in eti chloroplasts and in mature chloroplasts (Bazzaz and Rebeiz, 1978; Smith and Rebeiz, 1979). It constitutes the bulk (90–95%) of the Pchl pool in etiolated tissues (Rebeiz *et*

al., 1970), in greening tissues that have emerged from their lag phase (Rebeiz *et al.*, 1975c), and in tissues greening under a dark-light photoperiodic regime (Cohen *et al.*, 1977). It becomes a minor component of the Pchl pool in etiolated tissues during the lag phase of greening.

The Pchlde pool of etiolated tissues has been shown to consist mainly of DV Pchlde (E443F625) and of MV Pchlde (E437F625) (Bélanger and Rebeiz, 1979, 1980a). These two components were separated by chromatography on thin layers of polyethylene from monocotyledonary and dicotyledonary etiolated tissues, and their spectroscopic properties in ether, at room temperature and at 77°K (Fig. 14 B,a and c) have been described (Bélanger and Rebeiz, 1980a). Their ubiquitous presence in etiolated tissues was also confirmed by extensive matrix analysis of several plant extracts (Bélanger and Rebeiz, 1980a). The chemical structure of DV Pchlde was determined by Jones (1963) who first detected it in inhibited cultures of *Rp. spheroides*. Later Ellsworth and Aronoff (1969) reported the occurrence of DV Pchlde in UV-*Chlorella* mutants; it was not recognized, however, as a major component of the Pchlde pool of higher plants until recently (Rebeiz *et al.*, 1979; Bélanger and Rebeiz, 1979, 1980a).

In addition to DV and MV Pchlde, the Pchlde pool of etiolated tissues was shown to contain small amounts (4–7%) of a Pchlde-like compound with a Soret excitation maximum at 453 nm and an emission maximum at 640 nm in ether at 77°K (Fig. 14 A,b; B,b). This compound was designated Cp (E453F640) (Bélanger and Rebeiz, 1980a) and was subsequently shown to be a hexacoordinated Pchlde, which is formed in small amounts in ether matrices at 77°K (Bélanger and Rebeiz, 1981). Finally, the Pchlde pool of etiolated tissues was also shown to contain a certain amount of a fourth Pchlde-like spectroscopic species, which was designated Cp (E450F626) on the basis of its fluorescence properties at 77°K in ether (Figs. 14 A,c and B,c) (Bélanger and Rebeiz, 1980a). This component has now been attributed to the resolved Bx (O–O) transition of DV Pchlde (Belanger *et al.*, 1982).

It was also observed that the proportion of MV and DV Pchlde varied considerably under different growth conditions. For example, while in etiolated tissues, MV Pchlde *a* was the major constituent of the Pchlde pool, DV Pchlde *a* became the preponderant Pchlde species in etiolated tissues incubated with δ -aminolevulinic acid (ALA). On the other hand DV Pchlde became the major constituent of the regenerated Pchlde pool in etiolated tissues exposed to light and returned to darkness. The same was also found to be the case in tissues greening under a photoperiodic regime or under continuous light (Bélanger and Rebeiz, 1980a). Altogether the preceding results suggest that the Pchlde pool of

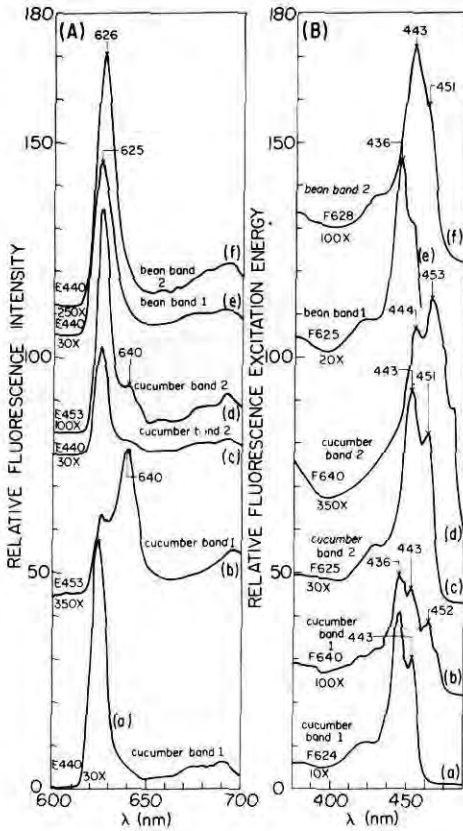

FIG. 14. Fluorescence emission (A) and excitation (B) spectra in ether at 77°K of the individual Pchlde species separated by chromatography on thin layers of polyethylene. Band 1, MV Pchlde pool; band 2, DV Pchlde pool. All other symbols and conditions are as in Fig. 3. (From Bélanger and Rebeiz, 1980a.)

green plants is a complex and dynamic pool that seems to adjust its chemical composition to the environmental growth conditions.

b. Biosynthesis of the Protochlorophyllide Pool. All the past biosynthetic studies dealing with this pool were carried out before its chromophoric heterogeneity was fully realized (Rebeiz *et al.*, 1978). In summary, these earlier studies established the following biosynthetic relationships. (a) Mg–Proto monoester (MPE) (VI,c and d; Fig. 1) Mg–Proto (VI,e and f; Fig. 1) and Proto (VII; Fig. 1) were converted into Pchlde *in vitro* (Ellsworth and Hervish, 1975; Mattheis and Rebeiz, 1977a,b). This in turn demonstrated unambiguously the precursor–product relationship of these tetrapyrroles to Pchlde and established their function as biosynthetic intermediates of the Chl biosynthetic pathway. (b) NAD, Pi, CoA, and ATP, in addition to S-adenosyl-L-methionine, were shown to

be required for the conversion of Mg-Proto into Pchl_{id}e (Ellsworth and Hervish, 1975). (c) The reactions between Pchl_{id}e and MPE were shown to be irreversible (Mattheis and Rebeiz, 1977c). (d) Finally a group of metalloporphyrins designated by the acronym LWMP (i.e., long wavelength metalloporphyrins) was detected in greening tissues and postulated to represent the missing metabolic intermediates between MPE and Pchl_{id}e (Rebeiz *et al.*, 1975a). A more detailed description of these putative intermediates will be given in Section IV,D.

Unfortunately, no information is yet available about the rigorous biosynthetic relationship of DV Pchl_{id}e to MV Pchl_{id}e. After the detection of DV Pchl_{id}e in *Rp. spheroides* by Jones (1963), it was suggested by him, on purely logical grounds, that the only function of DV Pchl_{id}e was that of a precursor of MV Pchl_{id}e *a*, whereas Ellsworth and Aronoff (1969) did not assign any apparent function to DV Pchl_{id}e *a*. The following evidence seems to argue however against Jones' functional assignment: (a) The independent photoreduction of DV and MV Pchl_{id}e into MV and DV Chl_{id}e *a* (Section IV,B). (b) The detection of MV MPE in UV-induced *Chlorella* mutants (Ellsworth and Aronoff, 1969). (c) The detection of MV MPE, MV Mg-Proto, and MV Proto pools in higher plants (Section IV,E, G, and H). Altogether these observations suggest that the MV and DV biosynthetic branches function as separate entities, each with its own metabolic intermediates as depicted in Fig. 11. Whether in addition to the DV Chl_{id}e *a* to MV Chl_{id}e *a* conversion (Duggan and Rebeiz, 1982c) other biosynthetic reactions do link the DV and MV acidic branches of the Chl biosynthetic pathway (Fig. 11) remains to be determined by rigorous *in vitro* experimentation. It is possible that some kind of an NADPH-reductase may be involved in these cross reactions (Ellsworth and Hsing, 1973). It is also possible that the drastic reduction in the level of NADPH following the illumination of etiolated tissues (Mapleston and Griffiths, 1978) may be related to such reactions.

2. STRUCTURE AND FORMATION OF THE PROTOCHLOROPHYLLIDE ESTER POOL

a. Structure of the Protochlorophyllide Ester Pool. The Pchl_{id}e ester pool, like the Pchl_{id}e pool, is bound to the membranes of the plastids (Smith and Rebeiz, 1979) and is found in etiolated tissues (Rebeiz *et al.*, 1970), in greening tissues (Rebeiz *et al.*, 1975c; Cohen *et al.*, 1977), as well as in green mature tissues (S. McCarthy and C. A. Rebeiz, unpublished work). In general, it amounts to 5–10% of the total Pchl pool, depending on the age and growth conditions of the tissue. At the

beginning of the lag phase of greening, it becomes the main component of the Pchl pool.

The Pchl ester pool of etiolated tissues was found to be more or less a faithful copy of the Pchl ester pool, but it is one in which the fluorescent components are esterified and blue-shifted by about 1 nm in their fluorescence emission and excitation maxima (Bélanger and Rebeiz, 1980c). It consists of DV Pchl ester (E442F624) (Fig. 15,e) and of MV Pchl ester (E436F624) (Fig. 15, a). In contrast to the Pchl ester pool however (Section IV,C,1,a), the composition of the Pchl ester pool remained fairly constant and appeared to be independent of the growth and greening conditions of the tissue.

b. Biosynthesis of the Protochlorophyllide Ester *a* Pool. New experiments indicate that, contrary to previous beliefs (Bogorad, 1966), the Pchl ester pool is not formed from the Pchl ester pool by simple

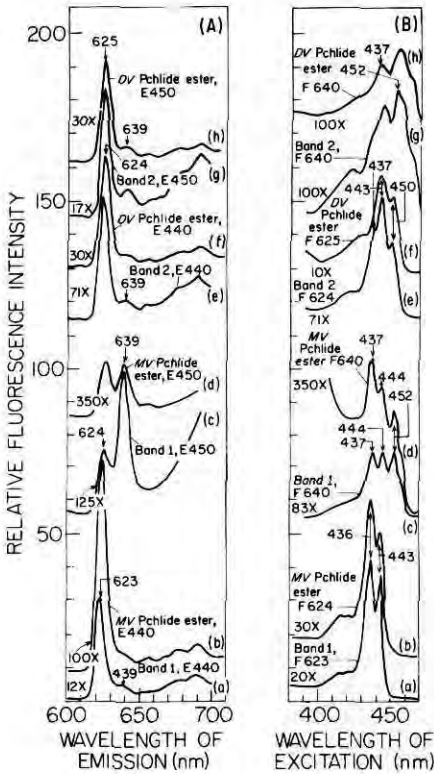

FIG. 15. Comparison of the fluorescence emission (A) and excitation (B) spectra in ether at 77°K of the individual Pchl ester species separated by chromatography on thin layers of polyethylene, with standard MV and DV Pchl ester prepared from pumpkin seed coat. Band 1, MV Pchl ester *a* pool; band 2, DV Pchl ester *a* pool. All other symbols and conditions are as in Fig. 3. (From Bélanger and Rebeiz, 1980c.)

esterification but that both pools are formed in parallel from a common precursor. The kinetics of ^{14}C incorporation into Pchlide *a* and Pchlide ester *a* *in vivo* was only consistent with biosynthetic models involving the simultaneous production of Pchlide and Pchlide ester in parallel from a common precursor (Rebeiz *et al.*, 1970). When cell-free systems capable of catalyzing the biosynthetic steps between Proto and Pchl became available, the early *in vivo* work (Rebeiz *et al.*, 1970) was reexamined with precursor-product experiments *in vitro*. It appeared from these studies that in greening tissues, the Pchlide ester and Pchlide pools were not metabolically interconnected. This conclusion was drawn from the inability of ^{14}C Pchlide to be converted into ^{14}C Pchlide ester, and vice versa, in cell-free systems capable of converting exogenous Proto into Pchlide and of converting exogenous ^{14}C Pchlide into ^{14}C Chl *a* in the light (Mattheis and Rebeiz, 1977c). Finally, in order to determine the common precursor of Pchlide ester and Pchlide, McCarthy *et al.* (1982) performed a detailed kinetic analysis of the precursor-product relationship between several ^{14}C -tetrapyrrole intermediates and ^{14}C Pchlide ester *a* *in vitro*. Since ALA is the proven precursor of both Pchlide and Pchlide ester, the ratio R-ALA of ^{14}C Pchlide ester- ^{14}C Pchlide produced upon feeding ^{14}C ALA *in vitro* could be conveniently used to determine which exogenous ^{14}C -substrate was a common precursor of Pchlide and Pchlide ester and which one was not. It was shown that any intermediate (X) up to and including the common precursor would have an R-X ratio equivalent to the R-ALA value, whereas any intermediate past the common precursor would have an R-X ratio significantly different from the R-ALA value. The common precursor of the Pchlide and Pchlide ester pools was found to be either Proto or Mg-Proto, but not MPE. The latter was the preferred precursor of the Pchlide *a* pool (Rebeiz *et al.*, 1978; McCarthy *et al.*, 1982). In Fig. 11, the common precursor of the Pchlide ester and Pchlide pools was considered to originate at the level of the Mg-Proto pool instead of Proto. This choice was motivated by the observation that a Proto diester intermediate has not yet been observed in higher plants, whereas a Mg-Proto diester has been recently detected in higher plants and in etiolated cultures of *Euglena* (Section IV,F).

The biosynthetic relationship of the DV Pchlide ester *a* pool to the MV Pchlide ester *a* pool has not yet been investigated. In Fig. 11, these two pools were assigned to two different fully esterified subbranches of the pathway for the same reasons that the DV and MV Pchlide *a* pools were assigned to two different acidic subbranches of the pathway (Section IV,C,1,b), namely, (a) the independent photoconversion of the DV and MV Pchlide ester pools into DV and MV Chl *a*, respectively (e.g.,

Section IV,A,1) and (b) the recent detection of DV and MV Mg-Proto diester in higher plants and in dark-grown cultures of *Euglena* (Section IV,F).

3. STRUCTURE AND FORMATION OF THE PROTOCHLOROPHYLL HOLOCHROME POOL

The immediate precursors of the DV and MV Chlide *a* and Chl *a* pools of green plants are the DV and MV Pchl chromophoric species, which were described in the preceding sections. However, in their native state in the plastids, these Pchl chromophores exist in very specific association with apoproteins (Boardman, 1966). Smith and Young (1956) proposed the term *protochlorophyll holochrome* (Pchl-H) to designate these Pchl-protein complexes. The Pchl-H's of higher plants have been extensively studied and reviewed in the past (Kirk, 1970; Rebeiz and Castelfranco, 1973) before the chromophoric complexity of the Pchl pool was understood. In the following discussion, an effort will, therefore, be made to interpret some of the old and new observations in terms of the apparent chromophoric multiplicity of the Pchl pool.

a. Composition of the Pchl-H Pools of Etiolated Tissues. Soon after the extraction of an active Pchl-H from bean seedlings was described by Smith and Kupke (1956), Shibata (1957) was able to demonstrate, with his opal glass technique, that the Pchl-H pool was made up of two Pchl-H species with absorption maxima, in situ and at room temperature, at 650 nm (Pchl-H650) and at 636 nm (Pchl-H636). Pchl-H 650 was phototransformable (i.e., photoreducible into Chl(ide) *a*) in the light, whereas Pchl-H636 was not.

With the reexamination of the Pchl-H pool by spectrofluorometry at 77°K, a more detailed understanding of this pool was achieved (Dujardin and Sironval, 1970; Kahn *et al.*, 1970). The low temperature was mandatory in order to prevent the phototransformation of the Pchl-H by the powerful excitation beam of the spectrofluorometer. From these studies, it was concluded that the Pchl-H was more complex than previously described by Shibata (1957), and it probably consisted of three Pchl-H species: (a) a nonphototransformable species that exhibited a red excitation-absorption maximum at about 628 nm and a corresponding fluorescence emission maximum at 630-632 nm, (b) a phototransformable Pchl-H species that exhibited a red excitation-absorption maximum at 637 nm, but which was not fluorescent since it transferred most of its excitation energy to a third Pchl-H species; and (c) a phototransformable and highly fluorescent species that made up the bulk of the Pchl pool in aging etiolated tissues, this being the third species. It

exhibited a red excitation-absorption maximum at 650 nm and a corresponding fluorescence emission maximum at 655–658 nm (Dujardin and Sironval, 1970; Kahn *et al.*, 1970).

In the preceding work, it was assumed that the Pchl chromophores of the Pchl-H species consisted mainly of MV Pchl and of small amounts of MV Pchl ester. These two Pchl chromophores were then assumed to associate differently with their macromolecular environment to yield the Pchl-H species that were just described (see earlier). When it was realized that the Pchl-H pool was made up of four different MV and DV Pchl chromophores (see earlier), Cohen and Rebeiz decided to reexamine the Pchl-H pool of etiolated tissues. It was conjectured that a finely tuned spectrofluorometric examination of this pool may reveal some additional Pchl-H species that were previously overlooked. As a result of these studies, two additional Pchl-H species were indeed detected (Cohen and Rebeiz, 1981). It appeared that the Pchl-H pool of etiolated cucumber cotyledons consisted of the following Pchl-H species: one nontransformable (nt) short wavelength (SW) Pchl, that is, nt-SW Pchl (E440F630); three partially transformable (t) SW Pchls, namely, t-SW Pchl (E443F633), t-SW Pchl (E444F636), and t-SW Pchl (E445F640); and one transformable long wavelength (LW) Pchl, that is, t-LW Pchl (E450F657) (Table III). The latter correspond to the conventional LW Pchl described by others. In etiolated bean leaves, the same Pchl species were detected as in cucumber cotyledons, but they were blue-shifted by 1–2 nm (Table III). These results lead to the conclusion that the Pchl chromophoric heterogeneity is accompanied by a concomitant Pchl-H heterogeneity *in situ*.

It is not presently clear which Pchl chromophore contributes to which Pchl-H species. It is evident that such a relationship can only be established when it becomes possible to isolate in a reasonably pure form the different Pchl-H species described earlier. So far this has not been achieved. The purest Pchl-H that have so far been isolated seem to have an apoprotein of about 45–170 KD, depending on the plant species (Henningsen *et al.*, 1974; Canaani and Sauer, 1977). To our knowledge the detailed Pchl chromophoric constitution of these purified Pchl-H has not yet been determined.

b. Composition of the Protochlorophyll-H Pool of Greening Tissues. Since prolonged etiolation may be considered as an abnormal condition imposed upon plant tissues in the laboratory, Cohen and Rebeiz (1978) tried to determine whether the contribution of the Pchl-H pool to the greening of plant tissues grown under a natural dark-light photoperiodic regime was identical to, or whether it differed from, the

TABLE III
Fluorescent Pchl Species Observed in Slices of Five-Day-Old
Cucumber Cotyledons and Bean Leaves^a

Tissue	Pchl species (77°K)	
	Short wavelength	Long wavelength
Cucumber	nt ^a -(E440 F630) ^b t-(E443 F633) t-(E444 F636) t-(E445 F640)	t ^a -(E450 F657)
Bean	nt-(E440 F630) t-(E441 F633) t-(E442 F636) t-(E443 F640)	t-(E447 F657)

^ant = nonphototransformable; t = phototransformable.

^bE refers to the Soret excitation maxima and F refers to the fluorescence emission maxima of the Pchl species. (From Cohen and Rebeiz, 1981.)

contribution of the Pchl-H pool to the greening of an etiolated tissue. During the dark cycles of photoperiodic greening, the Pchl-H pool of greening plants exhibited a different Pchl-H profile than that of etiolated tissues. During the early and late phases of photoperiodic greening, the t-SW Pchl-H species dominated the greening process. The conventional t-LW Pchl-H with an emission maximum at 657 nm, which is preponderant in etiolated tissues, appeared to play a transient role and to contribute to the greening process only during the middle phases of photoperiodic greening (Cohen and Rebeiz, 1978). More recent investigations of the SW and LW Pchl-H species of photoperiodic tissues have indicated that they were very similar to those of etiolated tissues (see earlier) (C. E. Cohen and C. A. Rebeiz, unpublished).

c. Biosynthesis of the Different Protochlorophyll-H Species. During the past decade, absorption (Horton and Leech, 1972, 1975; Griffiths, 1974, 1978) or fluorescence measurements (Mattheis and Rebeiz, 1978) have been made on cell-free systems, and these have become available for studying the biosynthesis of Pchl-H species *in vitro*. Horton and Leech (1975) demonstrated that ATP was involved in the conversion of SW Pchl-H species into t-LW Pchl-H (E447F657), whereas Griffiths (1974) presented evidence supporting the involvement of NADPH in this conversion. It is possible that both cofactors may be involved in this complex reaction. Otherwise little is known about the conversion of exogenous DV and MV Pchlide and Pchlide ester into nt-

SW Pchl-H species and the conversion of the latter into t-SW Pchl-H species. It may be pertinent to recall that in photoperiodically grown tissues, the major contributors to the greening process are the t-SW Pchl-H species (see earlier).

*D. Metabolic Intermediates between
Mg-Protoporphyrin Monoester and
the Protochlorophyllide a Pools*

The reactions between MPE and the Pchlide pool catalyze the conversion of the propionate methyl ester group at position 6 of the MPE macrocycle (VI,c,d; Fig. 1) into a five-membered ring, the cyclopentanone ring (III,c and d; Fig. 1). The latter is attached to the sixth and γ position of the Pchlide macrocycle. Granick (1950a) postulated that the formation of the cyclopentanone ring must include the oxidation of the β -carbon of the propionate residue, which subsequently cyclizes to give rise to the fifth ring (E) of the Chls and Pchls. It was not until 20 years later that supporting experimental evidence for the possible occurrence of a β -oxidation, at one of the peripheral propionate residues, became available (see in following section).

1. DETECTION OF THE PUTATIVE INTERMEDIATES BETWEEN
Mg-PROTOPORPHYRIN MONOESTER AND
PROTOCHLOROPHYLLIDE IN UV *CHLORELLA* MUTANTS

Ellsworth and Aronoff (1969), through the use of mass, visible, and infrared spectrometry, reported the detection of the putative intermediates between MPE and Pchlide *a* in UV-induced *Chlorella* mutants. Most of the porphyrins that accumulated in these mutants, occurred however as free bases, i.e., as porphyrins without a central metal atom. Nevertheless, two important observations were made in this communication: (1) some of the free porphyrin bases had acrylic, hydroxy, and keto propionate ester peripheral chains; (2) all the free bases as well as the Pchlide pool in the mutants occurred in the DV and MV oxidation state. These two observations in turn led the authors to the following general conclusions (a) that the metalated intermediates between MPE and Pchlide *a* were probably β -oxidation intermediates, i.e., acrylic, hydroxy, and keto derivatives of MPE (V; Fig. 1), and (b) that the reactions between MPE and Pchlide *a* involved two parallel pathways via which MV and DV analogs undergo β -oxidation (V; Fig. 1). In their metabolic scheme, however, the DV pathway ended at DV Pchlide *a*, which in turn was considered to be reduced eventually into Pchlide *a*. No other role was assigned to the DV branch of their pathway (Ellsworth and Aronoff, 1969).

2. DETECTION OF THE PUTATIVE INTERMEDIATES BETWEEN Mg-PROTOPORPHYRIN MONOESTER AND PROTOCHLOROPHYLLIDE IN HIGHER PLANTS

With the use of sensitive spectrofluorometric techniques, Rebeiz *et al.* (1975a) detected picomole amounts of several novel metalloporphyrins, which are now believed to represent the metabolic intermediates between MPE and Pchlide *a* in higher plants. Since these metalloporphyrins exhibited longer wavelength emission and excitation maxima than MPE, they were collectively named *long wavelength metalloporphyrins* (LWMP) (Rebeiz *et al.*, 1975a). These metalloporphyrins have since been detected in greening tissues of bean, maize, barley, and so on. They have been partially segregated on thin layers of silica gel "H," into three different groups; the components in every group were observed by selective spectrofluorometric excitation (Table IV; Rebeiz *et al.*, 1975a). The elucidation of the structure of these metalloporphyrins is now in progress. Preliminary results indicate that they may be the metalated analogs of the DV and MV acrylic, hydroxy, and keto porphyrin intermediates detected by Ellsworth and Aronoff in their UV *Chlorella* mutants (V; Fig. 1) (Ellsworth and Murphy, 1979; C. A. Rebeiz, unpublished work).

a. Evidence for the Metabolic Role of the Long Wavelength Metalloporphyrins in Higher Plants. The experimental evidence for the metabolic role of the LWMP of green plants was described earlier (Rebeiz *et al.*, 1978) and is summarized here. (a) The solubility, chro-

TABLE IV
Metalloporphyrins Accumulated by Greening Cotyledons^a

Band 3 ^b (R _f 0.4–0.56)	Band 2 ^b (R _f 0.32–0.48)	Band 1 ^b (R _f 0.2–0.43)	Identification
E416,F596		E418,F600	MPE N.I. ^c
	E420,F604		N.I.
E421,F603	E422,F608		N.I.
E426,F613		E427,F612	N.I.
	E428,F618		N.I.

^aE refers to the Soret excitation maximum; F refers to the short wavelength emission maximum in methanol:acetone (4:1 v/v) at room temperature.

^bThe ether extract of developing chloroplasts was segregated by thin layer chromatography in benzene:ethyl acetate:ethanol (8:2:2 v/v). The segregated bands were eluted in methanol:acetone (4:1 v/v).

^cN.I., not identified. (From Rebeiz *et al.*, 1975a.)

matographic, and spectrofluorometric properties of the LWMP suggest a very close structural relationship to the MPE and Pchl *a* pools (Rebeiz *et al.*, 1975a). (b) The LWMP accumulate during active greening and disappear when the greening process is interrupted by returning the tissue to darkness (Smith, 1978). The biosynthesis of the LWMP *in vitro* depends on the addition of exogenous ALA and on the cofactors needed for the biosynthesis of Pchl *a* from ALA *in vitro* (Rebeiz *et al.*, 1975b). (d) The net synthesis of the LWMP from ALA by isolated etiochloroplasts usually accompanies the net synthesis of Pchl *a* (Rebeiz *et al.*, 1975c). (e) In the presence of added cofactors, exogenous Proto or MPE is convertible into LWMP and into Pchl *a* *in vitro* (Mattheis and Rebeiz, 1977a; Ellsworth and Murphy, 1979). (f) Finally, when etiochloroplasts containing endogenous LWMP are incubated with cofactors, but in the absence of exogenous substrates, the LWMP appear to be converted into Pchl *a* (Mattheis and Rebeiz, 1977c). The preceding results justify the assignment of the LWMP to the metabolic sites depicted in Fig. 11. Further research about the stepwise enzymology of these metalloporphyrins is in progress.

b. Some Characteristics of the Reactions between Mg-Protoporphyrin Monoester and Protochlorophyllide. Preliminary investigations of the reactions between MPE and Pchl *a* in cell-free systems have so far indicated that these reactions (a) were irreversible (Mattheis and Rebeiz, 1977c); and (b) were not strictly specific for Mg-containing tetrapyrroles, since it was possible to show that when isolated etiochloroplasts were incubated with large amounts of synthetic Zn-Proto ester, the latter was converted into Zn-Pchl *a* (Rebeiz *et al.*, 1978).

E. Structure and Formation of the Mg-Protoporphyrin Monoester Pool

MPE (VI,c; Fig. 1) was first detected by Granick (1961) in an X-ray-induced *Chlorella* mutant and in etiolated barley seedlings treated with α,α -dipyridyl (an iron chelator) and ALA (Granick, 1959). It was identified as an esterified Mg-Proto, but the nature of the ester group was not determined. However, by analogy to Proto monomethyl ester, which was isolated and identified as such from the same mutant, Granick (1961) suggested that the ester group in MPE was also a methyl group. These observations led Granick to propose that MPE was probably a metabolic intermediate of the Chl biosynthetic chain between Mg-Proto and Pchl *a*. The occurrence of MPE in tissues of higher plants greening in

the absence of inhibitors was reported later (Rebeiz *et al.*, 1975a; Cohen *et al.*, 1977). Mattheis and Rebeiz (1977b) demonstrated the conversion of exogenous MPE into Pchl *a*, *in vitro*, thus ascertaining unambiguously the metabolic role of this tetrapyrrole in the Chl biosynthetic pathway.

The methyl nature of the ester group at position 10 of the phorbil macrocycle (that is position 6 of the porphyrin macrocycle), in higher plants, was suggested by the work of Ellsworth and St. Pierre (1975). These authors incorporated the [S-¹⁴C]methyl group of methionine into position 10 of the Chl *a* of greening wheat seedlings and demonstrated that the radioactivity was not in Chlorin-*e*₆ (Fig. 2f) obtained by destroying ring E and the ester group at position 10 of the [¹⁴C]Chl *a* macrocycle (I; Fig. 1). This was exactly what one would have expected if the [S-¹⁴C]methyl group from methionine was incorporated into the tenth position of the Chl *a* macrocycle during the conversion of Mg-Proto into MPE and the conversion of the latter into Chl *a* and if it were lost from that same position during the conversion of [¹⁴C]Chl *a* to Chlorin-*e*₆.

1. STRUCTURE OF

THE Mg-PROTOPORPHYRIN MONOESTER POOL

By applying the same spectrofluorometric and chromatographic techniques that were successful in elucidating the complex composition of the Pchl pools, Bélanger and Rebeiz (1982) demonstrated that the MPE pool of etiolated tissues, treated with α, α' -dipyridyl was heterogeneous and consisted of a MV MPE component in addition to the more conventional DV MPE component. These two pools were subsequently purified on thin layers of polyethylene, and the mixed DV, MV nature of the metalated and demetalated porphyrin moieties was established by chemical derivatization. The metalated DV and MV tetrapyrroles exhibited emission maxima at 592 nm and 590 nm, respectively, and excitation maxima at 423 nm and 417 nm, respectively, in ether at 77°K. (Fig. 16,a,b). They were thus designated DV MPE (E423F592) and MV MPE (E417F590). Subsequently MV and DV MPE were detected in etiolated tissues incubated with ALA, in the absence of α, α' -dipyridyl, as well as in dark-grown *Euglena* cultures and in *Hosta sieboldii*, mutant BAM-1 (kindly donated by Kevin Vaughn of Miami University).

Altogether these results indicated that the MPE pool of green plants was heterogeneous and was made up of MV and DV MPE components. This lends further credibility to the DV and MV branches of the Chl biosynthetic pathway depicted in Fig. 11. At this stage, it is not yet clear however, whether MV MPE is a 2-ethyl, 4-vinyl MPE, a 2-vinyl, 4-ethyl MPE, or a mixture of both isomers.

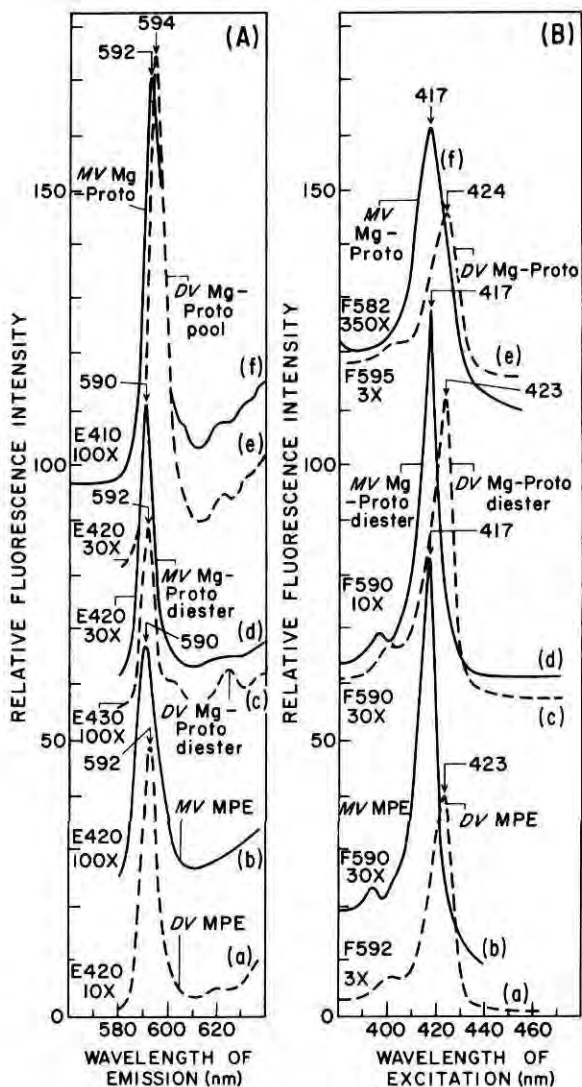

FIG. 16. Fluorescence emission (A) and excitation (B) spectra in ether at 77°K of the DV and MV Mg-porphyrin pools indicated on the spectra. The DV and MV Mg-Proto diester pools were purified from an etiolated *Euglena* culture on thin layers of polyethylene. The DV and MV MPE pools were purified on thin layers of polyethylene from etiolated cucumber cotyledons treated with α, α -dipyridyl. The Mg-Proto pool was purified on thin layers of silica gel H, from etiolated cucumber cotyledons treated with α, α -dipyridyl, but the DV and MV Mg-Proto components of this pool were not separated chromatographically; they were deconvoluted spectrofluorometrically by a proper choice of the excitation and emission wavelengths at which the spectra were recorded. (Adapted from Bélanger and Rebeiz, 1982.)

2. BIOSYNTHESIS OF THE Mg-PROTOPORPHYRIN MONOESTER POOL

All of the early work dealing with the biosynthesis of MPE in green plants was performed before the mixed DV and MV nature of that pool was recognized. The conversion of Mg-Proto (VI,e,f; Fig. 1) into MPE (VI,c,d; Fig. 1) by methylation of the propionate residue at position 6 of the macrocycle was first described by Tait and Gibson (1961) in chromatophores of *Rp. sphaeroides* (Section VII,D). In higher plants the enzyme (-)S-adenosyl-L-methionine magnesium protoporphyrin methyltransferase, which catalyzes the transfer of the methyl group from (-)S-adenosyl-L-methionine to Mg-Proto, was shown to be present in chloroplast preparations of *Zea mays* (Radmer and Bogorad, 1967). A detailed study of this enzyme in homogenates of wheat seedlings indicated that the enzyme was not inducible by light and was inhibited by MPE, Pchl_{ide}, Chlide *a*, pheophorbide *a*, and protopheophorbide *a* (Ellsworth and St. Pierre, 1976). The authors concluded that this enzyme was probably not a key regulatory enzyme of the Chl biosynthetic pathway.

When the mixed DV and MV nature of the MPE pool became evident, Rebeiz and Bélanger wondered whether the MV MPE was produced from DV MPE by reduction of the vinyl side chain at position 4 of the macrocycle, (VI,c and d; Fig. 1) or whether DV MPE and MV MPE were produced in parallel from two different precursors. It was conjectured that if DV and MV MPE were formed from two different precursors, the latter were most likely to be DV and MV Mg-Proto. When examined spectrofluorometrically at 77°K, the mixed DV and MV nature of the Mg-Proto pool became evident (Section IV,G). We therefore propose that DV MPE and MV MPE belong to the DV and MV Chl biosynthetic branches and that they are produced in parallel from DV and MV Mg-Proto, respectively (Fig. 11). This in turn raises the question of whether one or two different methyltransferases operate in the conversion of the Mg-Proto pool into an MPE pool. On the other hand, it appears from the work of Ellsworth and Hsing (1973, 1974) that the DV and MV MPE pools are probably interconnected by a Mg-4-ethyl-(4-desvinyl)protoporphyrin IX monomethyl ester: NAD⁺ oxidoreductase-mediated reaction, which was shown to convert DV MPE into MV MPE in the presence of exogenous NADPH.

F. Structure and Formation of the Mg-Protoporphyrin Diester Pool

When it became evident that the Pchl_{ide} ester and the Pchl_{ide} pools belong to two different Chl biosynthetic branches, namely, the fully esterified and acidic branches (Fig. 11) (Section IV,C), a search began

for the early biosynthetic intermediates of the esterified branch of the pathway. As a result of this effort, a substantial Mg-Proto diester pool was detected in etiolated cucumber cotyledons incubated with ALA and α,α' -dipyridyl (VI,a,b; Fig. 1) (McCarthy *et al.*, 1981). The pool was purified on silica gel "H" and was shown to be identical to the MPE pool in its spectrophotometric and spectrofluorometric properties, before and after demetalation and hydrolysis. Its chromatographic properties, however, were those of a tetrapyrrole lacking any free carboxylic functions. Several different long-chain alcohols appear to be involved in the esterification of the carboxylic function at position 7 of the macrocycle (McCarthy *et al.*, 1981). A Mg-Proto diester pool was also detected in dark-grown *Euglena* cultures. At the present time, it is not clear whether the Mg-Proto diester pool (VI,a,b; Fig. 1) is formed by esterification of the MPE pool (VI,c,d; Fig. 1) at the seventh position of the macrocycle or whether the Mg-Proto diester and MPE pools are produced in parallel from the Mg-Proto pool. At this stage, we are inclined to favor the latter hypothesis (Fig. 11) by analogy to the lack of significant biosynthetic relationship between the Pchlide and Pchlide ester pools (Section IV,C,2,b). This hypothesis seems to be compatible with the very limited conversion of [^{14}C]MPE into [^{14}C]Pchlide ester *in vitro* (McCarthy *et al.*, 1982).

A spectrofluorometric examination of the Mg-Proto diester pool at 77°K in ether revealed that, like the MPE pool, it consisted of DV Mg-Proto diester (E423F592) and of MV Mg-Proto diester (E417F590) (Fig. 16c, d). The latter was the predominant component of the Mg-Proto diester pool in dark-grown *Euglena* cultures (Bélanger and Rebeiz, 1982). The DV and MV Mg-Proto diester pools were subsequently purified on thin layers of polyethylene, and the mixed DV, MV nature of the demetalated porphyrin moiety was established (Bélanger and Rebeiz, 1982). Thus in Fig. 11, the Mg-Proto diester pool is depicted as two separate DV and MV pools, which initiate the DV and MV fully esterified branches of the Chl biosynthetic pathway. At the present time, it is not clear whether these two pools are biochemically interconnected, as appears to be the case for the DV and MV MPE pools or whether they are completely isolated from one another. It is not clear either whether MV Mg-Proto diester is a 2-ethyl-4-vinyltetrapyrrole, a 2-vinyl-4-ethyltetrapyrrole, or a mixture of both isomers.

G. Structure and Formation of the Mg-Protochlorophyllin Pool

Mg-protoporphyrin (Mg-Proto) (VI,e; Fig. 1) was first detected by Granick (1948) in an X-ray-induced *Chlorella* mutant. Subsequently, it

was also detected in etiolated barley seedlings treated with ALA and α, α' -dipyridyl (Granick, 1959). Since Mg-Proto accumulated in a *Chlorella* mutant blocked in its capacity to synthesize Pchl and Chl, Granick (1948b) proposed that Mg-Proto was an intermediate of the Chl biosynthetic pathway and was probably formed by the insertion of Mg into Proto. It was not until 1975, however, that the biosynthetic role of Mg-Proto was demonstrated unambiguously when Ellsworth and Herbish (1975) reported the conversion of [^3H -Mg]Proto into [^3H]Pchlide *in vitro*.

1. STRUCTURE OF THE Mg-PROTO POOL

The structure of Mg-Proto was determined, in parts, by Granick (1948b). The Mg-Proto from the *Chlorella* mutant was shown to be identical in its spectrophotometric properties to synthetic Mg-Proto dimethylester. The metal atom was shown to be a Mg atom and the porphyrin monoester moiety left after demetallation of the metalloporphyrin was shown to be identical in its electronic absorption properties to synthetic Proto (Granick, 1948b). These observations led Granick to conclude that by analogy to Proto, Mg-Proto was essentially a DV tetrapyrrole, i.e., a tetrapyrrole with two vinyl groups at position 2 and 4 of the macrocycle (V,e; Fig. 1). When the mixed DV, MV nature of the MPE pool became evident, a search was undertaken for the precursors of these two pools. This effort resulted in the discovery that the Mg-Proto pool was also a mixed DV and MV pool (Bélanger and Rebeiz, 1982), and it was proposed that the DV and MV Mg-Proto pools were the probable precursors of the DV and MV MPE pools. The mixed nature (DV-MV) of the Mg-Proto pool was demonstrated in etiolated cucumber cotyledons incubated overnight with ALA and α, α' -dipyridyl. The low temperature spectrofluorometric analysis of the purified pool indicated the presence of DV Mg-Proto (E423F594) and MV Mg-Proto (E417F592) (Fig. 16e, f). The DV and MV Mg-Proto components of the Mg-Proto pool were subsequently purified by chromatography on thin layers of polyethylene developed in 90% aqueous acetone (Bélanger and Rebeiz, 1982). It is still not clear, however, whether the MV Mg-Proto is a 2-ethyl-4-vinyl Mg-Proto, a 2-vinyl-4-ethyl Mg-Proto, or a mixture of both isomers.

2. BIOSYNTHESIS OF THE Mg-PROTO POOL

The early work concentrated on demonstrating that Mg-Proto was formed from Proto by insertion of Mg into the Proto molecule as suggested by Granick (1948b). This chelation reaction proved very elusive, however, and resisted duplication *in vitro* (Neuberger and Tait, 1964). It was finally possible to show that in the presence of the cofactors needed

for the biosynthesis of Pchl *in vitro*, including ATP, exogenous Proto was convertible into the MPE-equivalent by isolated etiochloroplasts (Smith and Rebeiz, 1977a,b). Subsequently, the chelation of Mg by Proto was shown to be catalyzed by a membrane-bound enzyme (Smith and Rebeiz, 1979). It should be stressed that the insertion of Mg into Proto appears to be tightly coupled to the conversion of the nascent Mg-Proto into MPE. This was first noted by Gorchein (1972), who proposed that the chelation reaction is obligatorily coupled to the esterification of the nascent Mg-Proto. In our opinion, the chelation and esterification reactions are probably tightly, but not obligatorily, coupled, since both Mg-Proto and MPE can be induced to accumulate in etiolated tissues treated with α,α' -dipyridyl.

Castelfranco *et al.* (1979) reported that, in the presence of glutamate and of some of the cofactors required for the maintenance of plastid integrity *in vitro* (Rebeiz *et al.*, 1973a), crude preparations of etiochloroplasts catalyzed the biosynthesis of massive amounts of Mg-Proto + MPE without the concomitant formation of Zn-Proto artifacts. Subsequently, it was shown that glutamate was not a cofactor involved in the chelation reaction; the high level of ATP, generated from glutamate by contaminating mitochondria, was responsible for the absence of Zn chelation and for the very high rates of Mg chelation *in vitro* (Pordo *et al.*, 1980). It should also be mentioned that a specific ATP requirement for the chelation of Mg by Proto was reported earlier by Gorchein (1973) for whole *Rp. sphaeroides* cells.

With the discovery that the Mg-Proto pool was a mixed DV and MV pool, the question of the origin of the DV and MV Mg-Proto pools naturally arose. This in turn led to a search for the precursors of the two Mg-Proto pools. As described later (Section IV,H), it now appears that DV and MV Mg-Proto are produced in parallel from DV and MV Proto. At the present time, it is not clear whether the DV and MV Mg-Proto pools are biochemically interconnected or not. It is not clear either whether or not two different Mg-Proto chelatasases are involved in the chelation of the DV and MV Proto pools.

H. Structure and Formation of the Protoporphyrin Pool

Proto (VII) was first detected in plants by Fischer and Schwerdtel (1928). When Granick (1948a) observed the accumulation of Proto in an X-ray-induced *Chlorella* mutant inhibited in its capacity to form Chl, he postulated that Proto was probably a precursor of Chl in green plants. The role of Proto as a precursor of Chl was demonstrated unambiguously when exogenous Proto was converted into Pchlide (Mattheis

and Rebeiz, 1977b) and into Mg-Proto + MPE *in vitro* (Smith and Rebeiz, 1977b).

1. STRUCTURE OF THE PROTO IX POOL

The structure of Proto IX (VIIa), of animal sources, was demonstrated by Fischer and co-workers early in the twentieth century (Fischer and Orth, 1937). In his efforts to characterize the Proto pool of the Proto-accumulating *Chlorella* mutant, Granick (1948a) proceeded as described here. First, the divinyl nature of the Proto pool was tentatively determined from the correspondence of its absorption spectrum in ether to that of standard Proto, as well as from its HCl number and from its melting point after conversion to Proto dimethyl ester. Further evidence of the DV nature of this porphyrin was determined from the capacity of a *Chlorella* mutant lacking Proto IX to support the growth of *Haemophilus influenzae* and from the capacity of this organism to reduce nitrate to nitrite in the presence of vinyl-containing porphyrins. Finally, the Proto pool was identified as a Proto IX isomer by converting the *Chlorella* Proto pool into Meso-Proto dimethyl ester (i.e., into a porphyrin dimethyl ester in which the two vinyl groups were reduced to ethyl groups) and by comparing the melting point of the latter to the melting point of standard Meso-Proto dimethyl ester.

When the DV and MV mixed nature of the Mg-Proto pool became evident, the question was immediately raised by Rebeiz and co-workers as to whether the MV Mg-Proto was synthesized from DV Mg-Proto by reduction of one of the vinyl chains or whether the DV and MV Mg-Proto were formed from one or two different precursors. Thus, a careful reexamination of the Proto pool of etiolated tissues that were induced to accumulate Proto by treatment with α, α' -dipyridyl (Granick, 1959) was undertaken with a high resolution spectrofluorometer. It was observed, as was found for all the Mg-porphyrin pools (see earlier), that the Proto pool of etiolated tissues was heterogeneous and consisted of small amounts of MV Proto in addition to DV Proto (Fig. 17). More recently a mixed MV-DV Proto pool was biosynthesized *in vitro* from exogenous ALA incubated with isolated etioclroplasts (N. Kuhadja and C. A. Rebeiz, unpublished). In pyridine at 77 K, the MV Proto pool exhibited an emission maximum at 627 nm and a Soret excitation maximum at 409 nm, whereas the DV Proto pool exhibited an emission maximum at 629 nm and a Soret excitation maximum at 414 nm (Fig. 17) (Rebeiz *et al.*, 1981). These two Proto components were, therefore, designated DV Proto (E414F629) and MV Proto (E409F627). At the present time, it is not clear whether the MV Proto pool is a 2-ethyl-4-vinyl-Proto, a 2-vinyl-4-ethyl-Proto, or a mixture of both isomers.

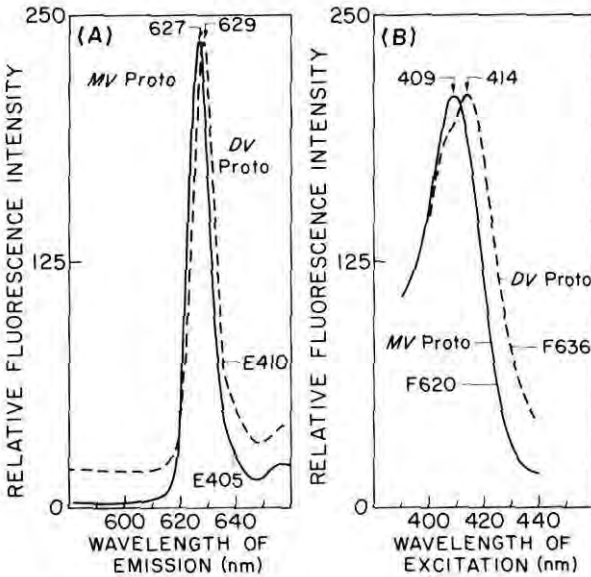

FIG. 17. Fluorescence emission (A) and excitation (B) spectra in pyridine at 77°K of the Proto pool of etiolated cucumber cotyledons treated with α,α -dipyridyl. The spectra were recorded on an SLM spectrofluorometer Model 8000 DS equipped with dual excitation holographic monochromators and interfaced with a Hewlett Packard 9825A microcomputer. The emission spectra were elicited by the excitation wavelengths E indicated on the spectra and were recorded at an excitation bandwidth of 2 nm and an emission bandwidth of 1 nm. The excitation spectra were recorded at the emission wavelength, $F\lambda$ depicted on the spectra with an emission bandwidth of 2 nm and an excitation bandwidth of 1 nm. The excitation spectra were normalized by the computer to the same amplitude at 409 nm and 414 nm, respectively. Although the DV and MV Proto pools were not chromatographically separated, their individual fluorescence and Soret excitation maxima were elicited by the proper choice of emission and excitation wavelengths. All symbols are as in Fig. 3. (Adapted from McCarthy and Rebeiz, 1982.)

2. BIOSYNTHESIS OF THE PROTO POOL

It was suggested by Granick (1961) that in animal mitochondria Proto was probably formed from protoporphyrinogen (Protogen) (VIII; Fig. 1) by an enzymatic oxidation that involves the removal of six hydrogens from the Protogen ring. Such a reaction can also occur nonenzymatically (Granick, 1961). Jacobs and Jacobs (1975, 1977) indicated that this reaction could occur anaerobically in *E. coli* particles, using fumarate as an alternate electron acceptor, or aerobically (Jacobs and Jacobs, 1979). The aerobic oxidation appeared to be involved mainly in the formation of Proto for heme synthesis (Jacobs and Jacobs, 1979). In hemolysates of chicken erythrocytes, the final oxidation of Protogen to Proto seems to

be essentially a stereospecific process in which removal of hydrogen occurs from one side of the molecule (Jackson *et al.*, 1976b). To our knowledge, these studies have not been extended to green plants, and the occurrence and properties of Protogen dehydrogenase in green plants remain uncertain.

It has become apparent that a compartmentation of the Chl biosynthetic pathway probably takes place during the conversion of Protogen to Proto. Indeed Smith and Rebeiz (1979) demonstrated that the initial formation of Proto (and therefore of Protogen) from ALA was catalyzed by soluble stromal enzymes. The nascent Proto became membrane bound rather rapidly and was converted into Mg-Proto + MPE by membrane-bound enzymes.

It is not presently clear whether the DV and MV Proto pools are formed from DV and MV Protogen or whether DV Protogen is formed first from coproporphyrinogen III (Coprogen) and then partially converted into MV Proto during its oxidation to Proto. Thus in Fig. 11, the mixed Proto pool is shown to originate somewhere either from Coprogen or Protogen. It is not clear either whether the MV and DV Proto pools are biochemically interconnected or not.

I. Biosynthesis of Protoporphyrinogen IX

When cell-free systems capable of converting ALA (XII; Fig. 1) to porphobilinogen (PBG) (XI; Fig. 1) and capable of converting PBG to porphyrins and Proto (Granick, 1954; Bogorad and Granick, 1953) became available, attempts were made to study the stepwise enzymology of these reactions. These efforts did not succeed until it was recognized that the true intermediates between PBG and Proto were not oxidized porphyrins but were colorless hexahydroporphyrins, i.e., porphyrinogens (Bogorad, 1955; Neve and Labbe, 1956).

Coprogen oxidase, the enzyme that catalyzes the oxidative decarboxylation of Coprogen III (IX; Fig. 1) [Coprogen III \rightarrow Protogen IX + 2 CO₂ + 4H], was first described by Sano and Granick (1961) in beef liver mitochondria and was subsequently detected by Granick and Mauzerall (1958) in cell-free extracts of *Euglena*. The enzyme has also been purified from tobacco leaves and its activity was enhanced by increasing Fe²⁺ concentrations up to 0.5 mM (Hsu and Miller, 1970). The animal oxidase required molecular oxygen and attacked mainly Coprogen III.

The mechanism of action of this enzyme has been the subject of considerable interest in the past decade. Most of the work was performed however with cell-free systems of animal origin. Sano and Granick (1961) recognized that the first intermediate of the oxidative decar-

boxylation of Coprogen III was probably a tripropionate porphyrinogen. Jackson and co-workers (Al-Hazimi *et al.*, 1976; Games *et al.*, 1976; Smith *et al.*, 1976a, b; Elder *et al.*, 1978; Jackson *et al.*, 1978) showed that in animal systems the propionate residue at the second position of the macrocycle (IX; Fig. 1) is first hydroxylated (Sano, 1966) and then loses a hydroxyl and carboxyl group simultaneously to give rise to harderoporphyrinogen (Harderogen). The latter is a derivative of Coprogen with one vinyl group at position 2 and one propionate group at position 4 of the Coprogen macrocycle. It is believed that subsequently the Harderogen undergoes a rapid anticlockwise rotation and the second propionate at position 4 is then oxidatively decarboxylated to yield Protogen IX. The formation of Harderogen has also been detected during the enzymatic conversion of Coprogen III to Proto IX in cell-free preparations of *Euglena* (Cavaleiro *et al.*, 1974). This suggests that in green plants the mechanism of Coprogen III oxidative decarboxylation may be identical to that in animal systems.

J. Biosynthesis of Coproporphyrinogen III

Uroporphyrinogen III (Urogen) (X; Fig. 1) is decarboxylated to Coprogen III by the enzyme Urogen decarboxylase according to the reaction: $\text{Urogen III} \rightarrow \text{Coprogen III} + 4 \text{CO}_2$. Urogen decarboxylase was first isolated from rabbit reticulocytes by Mauzerall and Granick (1958). It has since been purified 72-fold from tobacco leaves (Chen and Miller, 1974). The activity of the purified enzyme was found to be inhibited by thiol reagents and by heavy divalent cations. It was more active toward Urogen III than toward Urogen I.

Jackson and co-workers, working with hemolysates of chicken red blood cells, have suggested that the decarboxylation probably proceeded in a sequential clockwise pattern during which the four acetic acid residues are decarboxylated starting with that on ring D and ending with that on ring C (Jackson *et al.*, 1976a, b; Smith *et al.*, 1976b). To our knowledge these studies have not yet been extended to green plants.

K. Biosynthesis of Uroporphyrinogen III

The biosynthesis of Urogen III (X; Fig. 1) from PBG (XI; Fig. 1) was first reported in higher plants by Bogorad (1958a,b), who demonstrated that 4 moles of PBG were converted to 1 mole of Urogen III by the cooperative action of two enzymes: PBG deaminase and Urogen III cosynthetase: $4 \text{PBG} \rightarrow \text{Urogen III} + 4 \text{NH}_3$.

The exact mechanism of this important reaction has been the subject

of considerable interest and speculation. Indeed it is during this complex reaction that drastic intramolecular rearrangements of the substrate(s) take place in order to form Urogen III instead of the Urogen I isomer. Urogen III is the actual metabolic precursor of Proto IX, and of PChls and Chls (Bogorad, 1966; Battersby, 1978) in higher and lower plants. It now appears from the elegant work of Frydman and co-workers (1973, 1978; Frydman and Frydman, 1975; Diaz *et al.*, 1979) that two PBG molecules condense head to head under the influence of the deaminase-cosynthetase enzyme complex to form a dipyrrolylmethane, which by the head-to-tail condensation of two additional PBG units is converted into Urogen III. The plausibility of this hypothesis was recently confirmed by Scott *et al.* (1976). The deaminase and cosynthetase have been highly purified from spinach leaves and wheat germ, respectively (Higuchi and Bogorad, 1974).

L. Biosynthesis of Porphobilinogen

ALA dehydratase catalyzes the formation of one molecule of PBG (XI; Fig. 1) from two molecules of ALA; in the process, two molecules of H₂O are eliminated: 2 ALA → PBG + 2 H₂O. The mechanism of this reaction has been studied in great detail (Shemin, 1968; Barnard *et al.*, 1977). ALA dehydratase has been purified from radish cotyledons, and some of the properties of the purified plant enzyme have been described (Shibata and Ochiai, 1977).

M. Formation of δ-Aminolevulinic Acid

δ-Aminolevulinic acid (ALA) was established as the first committed intermediate of heme biosynthesis by Shemin and Russell (1953) in work with avian erythrocytes. Since then, ALA has been shown to be the precursor of most pyrroles with biological function (Beale, 1978; Granick and Beale, 1978). The discovery of ALA was soon followed by the demonstration of ALA synthase activity in cell-free extracts from such disparate sources as avian erythrocytes and the photosynthetic prokaryote, *Rp. sphaeroides* (Gibson *et al.*, 1958; Kikuchi *et al.*, 1958). The enzyme catalyzes the condensation of succinyl-CoA and glycine with elimination of CO₂ derived from the carboxyl carbon of glycine and requires pyridoxal phosphate (Pyl P) as cofactor:

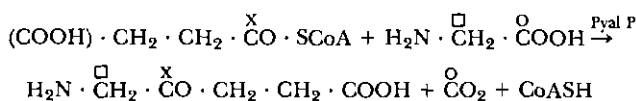

The presence of ALA synthase in animal tissues and in photosynthetic and nonphotosynthetic bacteria led, not unnaturally, to the belief that it was responsible for ALA formation in all types of cell. Repeated failure to find classical ALA synthase activity in preparations from higher plants and algae were attributed to technical problems, such as endogenous inhibitors and labile enzymes. It is now accepted that two major routes exist in nature for the production of ALA.

The possibility of an alternative pathway to ALA, though often discussed, was not pursued experimentally until Beale made ingenious use of levulinic acid. Nandi and Shemin (1968) had shown this compound to be a competitive inhibitor of ALA dehydratase, the next step on the Chl biosynthetic pathway (Fig. 11). Beale (1970, 1971) showed that cultures of *Chlorella* treated with levulinic acid accumulated ALA in amounts equivalent to the chlorophyll formed by the control cultures. Since then, levulinic acid has been widely used to block pyrrole synthesis in plant tissues in order to demonstrate the formation of ALA (Beale, 1978). It has been used for similar purposes with cultures of eukaryotic and prokaryotic blue-green algae (Jurgenson *et al.*, 1976; Kipe-Nolt *et al.*, 1978; Kipe-Nolt and Stevens, 1979).

The accumulation of ALA by application of levulinic acid permitted the study of the incorporation of labeled precursors and this approach was used by Beale and Castelfranco (1974a,b) in work with greening leaf tissue from cucumber, barley, and bean. Glutamate, α -ketoglutarate, and glutamine were shown to be effective precursors in contrast to glycine and succinate. Furthermore, glutamate labeled in the carboxyl group or in C₃ and C₄ was incorporated into ALA in similar amounts, indicating direct conversion of the 5-carbon skeleton to ALA. This was confirmed by degradation of ALA derived from the specifically labeled glutamate (Beale *et al.*, 1975). Similar types of experiment have indicated this route of ALA synthesis in cultures of the unicellular rhodophyte, *Cyanidium caldarium* (Jurgensen *et al.*, 1976) and in Cyanobacteria (Stevens and Kipe-Nolt, 1979).

1. PATHWAY FROM GLUTAMIC ACID

The direct pathway from C₅ dicarboxylic acids is now thought to be the major route of formation of ALA in higher plants, but the intermediates and enzymology are still a mystery. Several hypothetical pathways have been proposed, one of which involves the formation of dioxovaleric acid (DOVA) as an intermediate (Fig. 18; Beale, 1978). This compound requires transamination to form ALA, and it has some respectability as a putative intermediate since such a transaminase has been demonstrated in preparations from *Chlorella*, plant tissues, and

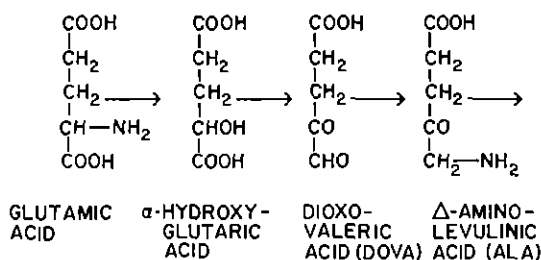

FIG. 18. A possible route to ALA from glutamic acid. (From Beale, 1978.)

bacteria. DOVA transaminase has been partially purified from *Rp. sphaeroides* (Turner and Neuberger, 1970). It requires L-alanine as amino donor and pyridoxal phosphate is apparently a cofactor. Other naturally occurring amino acids are not effective amino donors with the purified bacterial enzyme, whereas crude extracts from *Chlorella* can use many α -amino acids, of which glutamate, alanine, and phenylalanine are most effective (Gassman *et al.*, 1968).

In vitro systems are clearly required for analysis of the steps from the C_5 -dicarboxylic acids, and some progress has been made. Isolated chloroplasts from greening cucumber cotyledons form [^{14}C]ALA from [$U\text{-}^{14}\text{C}$]glutamic acid in a system containing levulinic acid and requiring light, ATP, and GSH for optimum conversion (Weinstein and Castelfranco, 1978); in the absence of levulinic acid, labeled metallo-Protos were synthesized (Castelfranco and Schwarcz, 1978). A similar activity has been found in soluble preparations from disrupted chloroplasts and the requirements included ATP and NADPH, but neither light nor levulinic acid was needed (Gough and Kannanaga, 1977).

A soluble system from greening maize leaves has been described by Harel *et al.* (1978), which incorporates 5- α -[^{14}C]ketoglutaric acid into ALA in the presence of alanine, pyridoxal phosphate, NAD and levulinic acid. The reaction was linear for at least 1 hour and was dependent on alanine, but ATP, CoA, and GSH were without effect. The quantities of ALA formed were minute, but if this problem can be overcome the system should be suitable for testing DOVA as an intermediate.

A partial purification of a soluble system from greening wheat has been achieved by Ford and Friedmann (1979). The preparation converts [$U\text{-}^{14}\text{C}$]glutamic acid to [^{14}C]ALA in the presence of ATP, GSH, and NADPH, and it is reported to be extremely labile prior to chromatography on carbomethoxycellulose. It seems likely that at least two enzymes participate in the overall conversion.

2. OTHER ROUTES TO δ -AMINOLEVULINIC ACID

The C_5 -dicarboxylic acid pathway has been found in higher plant tissues and algae in which photosynthetic pigments (Chl *a* and phycobilins) comprise the predominant pyrroles. This raises the question of whether the mitochondrial hemes are derived by the same route of ALA synthesis. In work with etiolated barley leaves, Castelfranco and Jones (1975) found [1- ^{14}C]glutamic acid to be effectively incorporated into protoheme and Chl *a* (isolated as pheophorbide *a*) and the specific radioactivities were similar. [2- ^{14}C]glycine was not significantly incorporated into either tetrapyrrole, leading to the conclusion that the C_5 dicarboxylic acid pathway serves for the synthesis of hemes and Chl in these preparations. A similar conclusion by another approach was reached in work with *Cyanidium caldarium* which forms Chl *a* and phycocyanin when exposed to light (Troxler and Offner, 1979). A mutant strain, which forms mitochondrial hemes but which does not form the photosynthetic pigments, incorporated specifically labeled glutamic acid and α -ketoglutaric acid into ALA in the presence of levulinic acid, and the labeling pattern was consistent with the C_5 pathway. Similar experiments with labeled glycine and succinic acid provided no evidence for the operation of ALA synthase.

In contrast to the observations discussed earlier, the operation of two pathways to ALA is suggested by work with a mutant strain of *Scenedesmus obliquus*, which forms Chl only upon exposure to light (Klein and Senger, 1978). Incubation of dark-grown cells in the presence of levulinic acid with specifically labeled glutamic acid or [2- ^{14}C]glycine resulted in the formation of ALA labeled in positions consistent with both pathways.

V. Formation of the Chlorophyll *b* Pool in Green Plants

The origin of the Chl *b* (1c and d; Fig. 1) pool in green plants has been a subject of debate and controversy for the past 30 years. The issue was well described about 2 decades ago by Smith and French (1963). In the intervening years, mainly through the research effort of Shlyk and co-workers (Shlyk, 1971), it has been more or less accepted that the Chl *b* pool is synthesized from newly formed Chl *a* molecules in the plastid membranes. However, the enzyme(s) responsible for the putative reactions have not yet been purified. The evidence up to 1973 has been

summarized (Rebeiz and Castelfranco, 1973), and work by Aronoff and Kwok (1977) seems to further confirm this hypothesis.

Mohr and co-workers (Oelze-Karow and Mohr, 1978; Oelze-Karow *et al.*, 1978), after a kinetic analysis of the fluctuation in the Chlide *a* and Chl *b* pool sizes in etiolated mustard cotyledons subjected to various light pretreatments, have suggested that the Chl *b* pool may be formed from the Chlide *a* pool instead of the Chl *a* pool.

It now appears that a portion of the Chl *b* pool may be formed via Chlide *b*. This hypothesis is prompted by the recent discovery of a major native Chlide *b* pool in greening tissues of higher plants (Duggan and Rebeiz, 1982a), which appears to consist of MV and DV Chlide *b* components and to be formed from transient DV Chlide *a* (Wu and Rebeiz, 1982). On the other hand, the conversion of exogenous Chlide *b* into Chl *b* *in vitro* has also been reported (Benz and Rüdiger, 1981).

VI. Regulation of the Chlorophyll Biosynthetic Pathway

There is little doubt that the regulation of Chl biosynthesis and accumulation is an integral part of the processes which are involved in the control and regulation of chloroplast development (see I. Ohad and G. Drews, in Govindjee, 1982). A discussion of the regulation of the greening process is, however, beyond the scope of this chapter. Thus, our discussion will be confined to an examination of the regulation of some of the biosynthetic reactions of the Chl biosynthetic pathway. It is already apparent from Fig. 11 and from the dearth of information concerning the biosynthetic and kinetic relationship of the four branches of the Chl pathway that even such a limited discussion will be superficial.

There is no doubt that the availability of ALA, which is the first intermediate of the Chl biosynthetic pathway, plays an important role in the gross regulation of the overall pathway. This is very evident from the fact that etiolated tissues that are no longer synthesizing Pchl will form and accumulate large quantities of additional Pchl upon treatment with ALA (Sisler and Klein, 1963). The availability of ALA appears to be under the control of a complex set of cellular processes that involve among other things phytochrome control and/or blue light-receptor control (Klein *et al.*, 1977; Oh-hama and Senger, 1978; Senger *et al.*, 1980). Furthermore, it has been suggested that the level of ALA in green plants may also be regulated by the level of heme or a particular heme compound (Duggan and Gassman, 1974; Castelfranco and Jones, 1975;

Gassman and Duggan, 1975). Gassman *et al.* (1978) have described an O₂-dependent enzyme system, which is capable of oxidizing ALA to CO₂ *in vivo* and *in vitro* and which may also be involved in the regulation of the ALA level in green plants.

Fine controls of the Chl biosynthetic pathway that may be as important to the greening process as the availability of ALA appear to operate on the Chl biosynthetic chain beyond ALA (Fluhr *et al.*, 1975; Schwartzbach *et al.*, 1976). One such control seems to be exerted at the level of PGB availability. Indeed Frydman *et al.* (1973b) identified a new enzyme system, which occurs in plants and which may be involved in regulating the level of PGB during greening. The enzyme PGB oxygenase was purified from wheat germ (Tomaro *et al.*, 1977). It converted PGB into inactive 2-hydroxy-5-oxoporphobilinogen and 5-oxoporphobilinogen; it was determined to be a multimer of MW 100,000, which dissociated freely into four subunits of 25,000 each. The enzyme exhibited allosteric kinetics only in the aggregated form (Tomaro *et al.*, 1977). This enzyme was subsequently found in pepper and poinsettia leaves (Frydman *et al.*, 1979) and is now considered to occur in cationic and anionic forms (Tomaro and Frydman, 1979). It is suggested that the activity of these isozymes may be modulated by an unidentified protein inhibitor (Mendy *et al.*, 1979).

Regulation of the Chl biosynthetic pathway may also occur at the level of MPE. Indeed Gassman and co-workers (1978; Vıcek and Gassman, 1979) suggested that degradative enzymes may be involved in the control of the level of MPE during greening.

McCarthy and Rebeiz (1980) detected an inhibitor of Pchl biosynthesis in an extract of cucumber cotyledons; this inhibitor may act only on the acidic branches of the Chl biosynthetic pathway between MPE and the Pchl_{ide} pools (Fig. 11) (McCarthy and Rebeiz, 1982). We now believe that this natural inhibitor may be involved in the regulation of the flow of intermediates between the acidic and the fully esterified branches of the Chl biosynthetic pathway (McCarthy and Rebeiz, 1982).

Finally, it has been known for some time that the reduction of Pchl into Chl(ide) plays an important role in the regulation of Chl biosynthesis and accumulation (Price and Klein, 1961; Virgin, 1961; Kasemir, 1979). This initial photoreduction step may also be involved in controlling the subsequent flow of intermediates via the MV and DV Chl *a* biosynthetic branches (Bélanger and Rebeiz, 1980a). For example, following the photoreduction of the Pchl_{ide} pool of an etiolated tissue, the regenerated Pchl_{ide} *a* pool is then mainly made up of DV Pchl_{ide}, which is convertible in the light into DV Chl_{ide} *a* (Duggan and Rebeiz, 1982b; Bélanger *et al.*, 1982).

VII. Synthesis of Hemes and Bacteriochlorophyll in Photosynthetic Bacteria

A. Biosynthesis of δ -Aminolevulinic Acid

Bacteria of the Rhodospirillaceae group have high ALA synthase activity when grown phototrophically and have provided a rich source of the enzyme for purification and for the study of its properties (Burnham, 1970; Jones, 1978). Several researchers have described purification procedures for the enzyme from *Rp. sphaeroides* and have shown it to be strongly inhibited by hemin and also by Mg-Proto and ATP (Lascelles, 1978). ALA synthase from this organism has been purified to homogeneity in Shemin's laboratory and found to be a dimeric protein with a MW of 80,300, and with two apparently identical subunits (Nandi and Shemin, 1977). This enzyme has been used for mechanistic studies (Nandi, 1978).

Purification of ALA synthase from *Rp. sphaeroides* has revealed multiple forms that separate as distinct peaks on columns of DEAE-Sephadex. Such multiplicity created confusion in the field, and this was compounded by the variations in enzyme activity observed in preparations from cells grown under different light intensity or in the presence of oxygen. This confusion has been minimized by the demonstration of high and low activity forms of the enzyme, which respond to sulfur compounds.

Active and inactive forms (*a* and *b*, respectively) were isolated from phototrophically grown *Rp. sphaeroides* and were shown to be interconvertible by treatment with thiols and disulfides such as cystine or GSSG as shown (Tuboi *et al.*, 1970):

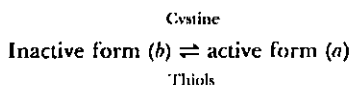

The activation by cystine was apparently enzyme-dependent (Hayasaka and Tuboi, 1974). An endogenous activator was isolated and identified as cystine trisulfide in Neuberger's laboratory; it converted the *b* form of ALA synthase to the *a* form, but was without effect on the latter (Sandy *et al.*, 1975; Wider de Xifra *et al.*, 1976). It was suggested that cystine trisulfide is formed from cystine by the action of cystathionase, an enzyme shown to be present in *Rp. sphaeroides*. Inoue *et al.* (1979) purified the activating enzyme concerned with cystine and identified it as cystathionase. In addition, a regulator protein is involved in the activation, and it has been purified to homogeneity (Oyama and Tuboi, 1979).

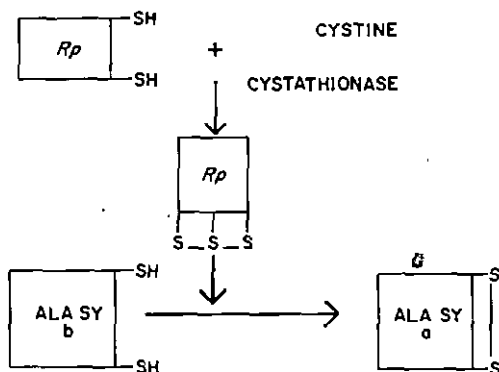

FIG. 19. Model proposed for regulation of ALA synthase in *Rp. sphaeroides* (after Oyama and Tuboi, 1979). *Rp.* = regulator protein; ALA Sy = ALA synthase. a = active enzyme form; b = inactive enzyme form.

The proposed model involves modification of the regulator protein to form a trisulfide structure a process catalysed by cystathionase in the presence of cystine; the modified regulator protein converts the *b* form to the *a* form by an intramolecular thiol-disulfide exchange (Fig. 19).

Complete understanding of the activation-inactivation phenomenon requires knowledge of the sulfur components of each form of ALA synthase. A high activity form has been purified to homogeneity from iron-sufficient cells of *Rp. sphaeroides* and shown to be mainly monomeric, with a MW of 49,000 (Davies and Neuberger, 1979). The protein is relatively low in sulfur residues with a total of 14 sulfur atoms per subunit, comprised of 5-6 cysteines and 8-9 methionines. ALA synthase with higher specific activity has been purified from iron-deficient cells and found to have two free SH groups per mole, in contrast to the less active form of the enzyme from iron-rich cells, which had one free SH per mole (Clement-Metral and Fanica-Gaigrier, 1975).

It is clear that the nutritional status and the growth environment influence the activity of the enzyme as isolated *in vitro*, and account for the rapid decline in enzyme activity observed upon aeration of phototrophically growing cultures. It was originally proposed that the loss of activity (conversion of *a* to *b* form) was attributable to a decline in the pool level of the trisulfide activator. However, this concept must now be abandoned, since less drastic conditions of aeration cause a decline in ALA synthase activity without altering the intracellular concentration of trisulfides and disulfides (Wider de Xifra *et al.*, 1976).

Finally, the role of sulfur-containing agents in the activation of ALA synthase has certain similarities to the well-established ferredoxin-thioredoxin reductase system discovered by Buchanan and co-workers in chloroplasts. Many enzymes concerned with the assimilation of carbon dioxide are regulated by oxidation-reduction reactions medi-

ated by reduced thioredoxin, derived from the photoreduction of ferredoxin (Wolosiuk and Buchanan, 1977, 1978). Some evidence for the presence of thioredoxin in *Rp. sphaeroides* has been reported (Clement-Metral, 1979), but whether this protein is concerned in the activation of ALA synthase is not established.

B. The Biosynthetic Reactions between δ -Aminolevulinic Acid and Protoporphyrin

1. THE REACTIONS BETWEEN δ -AMINOLEVULINIC ACID AND COPROPORPHYRIN

The pathway outlined in Fig. 11 indicates common intermediates for iron and magnesium tetrapyrroles to the stage of protoporphyrin. Siroheme and corrinoids are thought to arise from Urogen III, whereas hemes *a* and *c* may be derived from protoheme as discussed later. The common pathway seems to be universal and has been demonstrated in preparations from animal, plant, and microbial cells. Such preparations convert ALA to mixtures of porphyrinogens (or the stabilized porphyrin by-products) and usually the intermediates are formed in excessive amounts. Accumulation of intermediates also occurs in certain mutant strains of *Rp. sphaeroides* with partially defective enzymes. Such mutants have abnormally low levels of heme and BChl, as would be expected if one set of enzymes serves the Fe and Mg branches of the pathway (Lascelles, 1978).

Detailed knowledge of the individual enzymes and their mechanisms of action is, however, limited (Jones, 1978). *Rp. sphaeroides* has been the source of highly purified ALA dehydratase and PBG deaminase for intensive investigation by Shemin and co-workers (Shemin, 1976; Jordan and Shemin, 1973). Assembly of the Type III tetrapyrrole structure requires the concerted action of PBG deaminase and a cosynthase (Section IV, K). Work with purified preparations of these proteins from *Rp. sphaeroides* suggests that the assembly of the four PBG residues occurs sequentially (Jordan and Sehra, 1979).

2. PROTOPORPHYRIN FORMATION

The oxidation of Coprogen III to Proto has been studied in some detail in mitochondria from animal tissues and from yeast, but it remains a mysterious area in photosynthetic organisms. The overall reaction requires the removal of 10 hydrogen atoms and the activity has been found in preparations from many sources, but only under aerobic conditions. In mitochondrial preparations two distinct enzymes have been demonstrated, which catalyze respectively the oxidative decarboxylation

of coproporphyrinogen III to protoporphyrinogen IX and the oxidation of the latter to protoporphyrin IX:

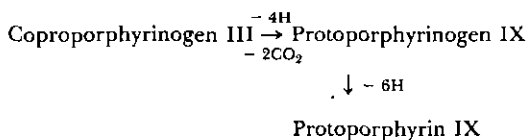

Yeast mitochondria are able to carry out the first step both aerobically and anaerobically, but the requirements for each system are very different (Poulson and Polglase, 1974). The oxygen-dependent system does not require cofactors and is relatively insensitive to inhibition by EDTA or *o*-phenanthroline. The anaerobic system requires NADP (or, less effectively, NAD), *S*-adenosylmethionine, and divalent or trivalent cations, of which Mn^{2+} , Fe^{2+} , or Fe^{3+} are most effective. The oxidation of Protogen to Proto in the mitochondrial preparations is obligatorily linked to oxygen; the oxidase has been partially purified from detergent-solubilized material (Poulson and Polglase, 1975; Poulson, 1976).

In the case of photosynthetic bacteria, which carry out anoxygenic photosynthesis under anaerobic conditions, oxygen is clearly not mandatory in the coproporphyrinogenase system. However, oxygen-dependent activity has been demonstrated in the cytoplasmic fraction of *Rp. sphaeroides* and *Chromatium vinosum* (Mori and Sano, 1972; Tait, 1972). The aerobic oxidation of Protogen to Proto has also been reported with extracts from *Rp. sphaeroides* (Jacobs and Jacobs, 1979). The anaerobic conversion of Coprogen III to Protogen has been demonstrated in extracts of phototrophically grown *Rp. sphaeroides*, and the requirements are complex (Tait, 1972). Both membrane and cytoplasmic fractions are needed, together with Mg^{2+} , *S*-adenosylmethionine, succinate, NADH, and NADP. The participation of iron is indicated by the strong inhibition with chelating agents such as *o*-phenanthroline. The system is extremely labile, and it has so far defeated attempts to resolve the complexities. It is not clear what hydrogen acceptor system serves as sink for the hydrogen atoms, nor is the role of *S*-adenosylmethionine understood. Possibly, non-heme-iron complexes, which are abundant in the chromatophore membrane, may be involved in the anaerobic coproporphyrinogenase system. Such a role for iron would be consistent with the low levels of BChl and the accumulation of coproporphyrin observed in iron-deficient cultures of *Rp. sphaeroides* and related bacteria (Lascelles, 1978).

Work with anaerobically grown *Escherichia coli* has given some insight

into the oxidation of Protogen to Proto. Under anaerobic conditions membranes can couple the oxidation of Protogen to the reduction of fumarate via the fumarate reductase system (Jacobs and Jacobs, 1976), and the overall reaction is inhibited by 2-heptyl-4-hydroxyquinoline *N*-oxide (HQNO). Exploitation of quinone and heme-deficient mutants has shown that menaquinone is required for the coupled oxidation-reduction, but cytochromes are not necessary (Jacobs and Jacobs, 1978).

C. Formation of Iron Porphyrins

1. SYNTHESIS OF PROTOHEME

The incorporation of ferrous iron into Proto is catalyzed by ferrochelatase, a membrane-associated enzyme which is widely distributed in eukaryotes and prokaryotes. This activity has been demonstrated in isolated chloroplasts and in etioplast and mitochondria from plants (Porra and Lascelles, 1968; Little and Jones, 1976). Ferrochelatase activity is high in membranes from *Rp. sphaeroides* and its specificity has been examined in detail (Jones and Jones, 1970). Porphyrin *c* is not active, whereas deuteroporphyrin and other unnatural dicarboxylic porphyrins are effective substrates. In fact, deuteroporphyrin is far more active than Proto and is more convenient to use for routine assay of the ferrochelatase. The enzyme in membranes from *Rp. sphaeroides* is also relatively unspecific for metals with the outstanding exception of magnesium; cobalt and zinc are actively incorporated (Neuberger and Tait, 1964; Wacker *et al.*, 1965; Jones and Jones, 1970). Ferrochelatases from *Rp. sphaeroides* and other sources are stimulated by phospholipids and detergents, which may facilitate access of the porphyrin substrate to the active center. The enzyme has been purified from membranes of *Spirillum itersonii* after initial solubilization with chaotropic salts (Dailey, 1977).

Iron in the Fe^{2+} state is required specifically by ferrochelatase and the enzyme is inhibited by oxygen. The provision of Fe^{2+} can be linked with oxidation-reduction steps of the respiratory chain, as membrane preparations from bacteria and from mitochondria use Fe^{3+} as a source of iron in the presence of respiratory substrates (Jones and Jones, 1970; Dailey and Lascelles, 1977). The coupling of Fe^{3+} reduction to the photosynthetic electron transfer system has yet to be investigated.

The orientation of ferrochelatase in the photosynthetic membrane is important to consider in relation to its substrates, protoporphyrin and Fe^{2+} . Barrett and Jones (1978) suggest that the enzyme in *Rp. sphaeroides* faces onto the cytoplasm of the cell. This conclusion is based on

observations with purified chromatophores derived from extracts made by the French pressure cell; such vesicles are oriented with the outer face representing the face toward the cytoplasm in the intact cell. Detergents do not affect ferrochelatase activity, as measured with Co^{2+} and deuteroporphyrin, indicating that the active center is accessible to these substrates in the vesicles.

2. FORMATION OF HEME *a*, HEME *c*, AND SIROHEME

The origin of the other hemes, which occur in various photosynthetic and nonphotosynthetic bacteria has received little attention. It is assumed that hemes *a* and *c* are derived from protoheme, but the evidence for this is slight and based largely on work with heme-deficient mutants of *Staphylococcus aureus* and *Spirillum itersonii* (Lascelles *et al.*, 1969; Garrard, 1972; Keyhani and Keyhani, 1978). A series of mutants have been described (Gollub *et al.*, 1977) which are blocked at the following stages: (a) ALA synthase; (b) ALA dehydratase; (c) PBG deaminase; (d) Coprogen III to Proto, and (e) ferrochelatase. These mutants have the useful property of being able to grow with hemin as supplement and thus can be used to study the origin of hemes *a* and *c*. Their characteristics also indicate that siroheme, the prosthetic group of sulfite reductase, is derived from Urogen III.

D. Formation of Bacteriochlorophyll

Progress in elucidating the steps of the magnesium pathway leading to BChl *a* has been slow and has been reviewed (Jones, 1978; Lascelles, 1978). Current information supports the sequence of intermediates shown in Fig. 20.

1. INSERTION OF MAGNESIUM AND FORMATION OF THE METHYLESTER GROUP

The enzyme catalyzing the insertion of Mg into protoporphyrin is likely to be critical in regulating the flow of intermediates into the magnesium branch of the biosynthetic pathway. The putative "Mg-chelatase" seems to be particularly labile in bacteria and activity in a cell-free system has yet to be demonstrated. Gorchein (1972, 1973) developed a whole-cell system with phototrophically grown *Rp. sphaeroides*, which incorporates Mg into exogenous Proto, with the formation of MPE. The requirements are complex, however, and chelators such as EDTA are needed, possibly to make the membrane permeable to Proto. Dependence upon the energized membrane state is indicated since incorporation requires illumination under anaerobic conditions or incubation with

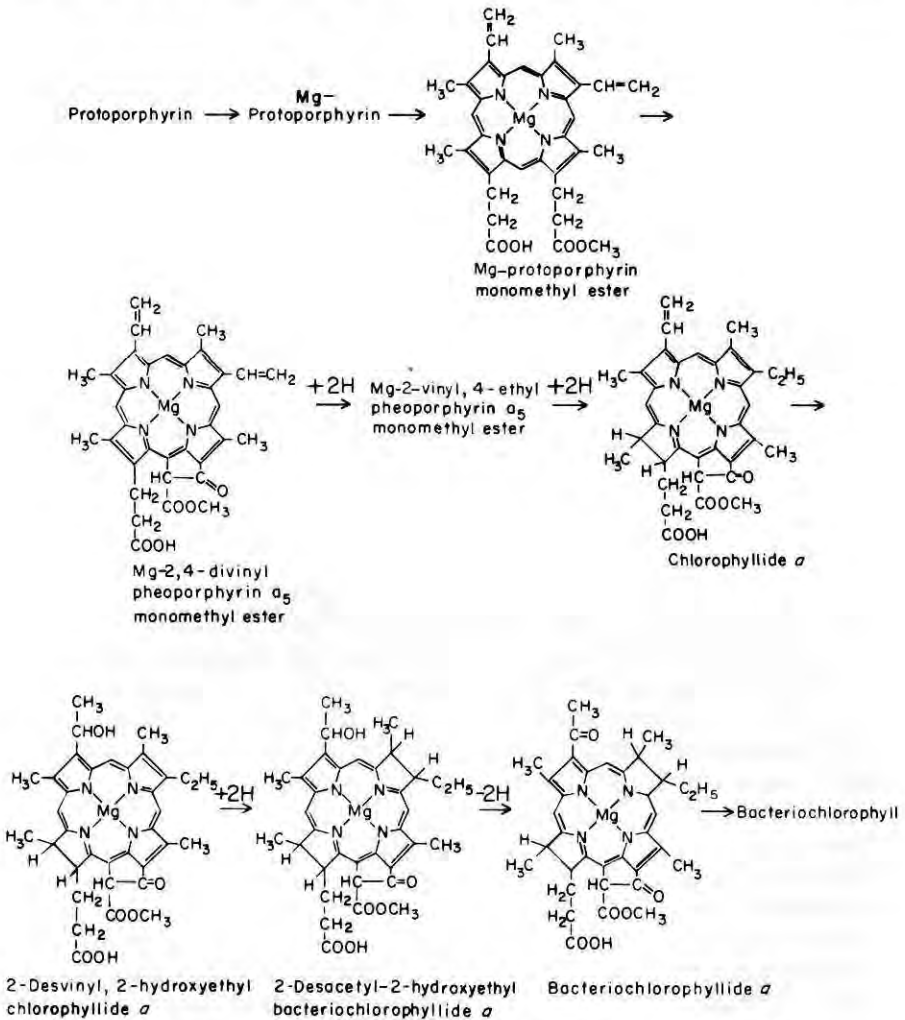

FIG. 20. Proposed route from Proto to BChl a . (From Jones, 1978.)

limited aeration in the dark. Uncouplers and inhibitors of electron transfer inhibit the reaction under both conditions. In addition, a requirement for *S*-adenosylmethionine was demonstrated in cells depleted of endogenous pools by dialysis. The incorporation of Mg may be tightly coupled to the methylation step, since only the methylester derivative was detectable in these systems. Some of the requirements for incorporation may concern the transport of exogenous Proto to the membrane-

associated chelatase. Progress with preparations from plant tissues is described in Section IV,G,2.

The methylation step, catalyzed by *S*-adenosylmethionine-Mg-proto-porphyrin methyltransferase, has been studied *in vitro* (Gibson *et al.*, 1963). This activity is located in the membrane fraction of phototrophically grown *Rp. sphaeroides* and in other photosynthetic bacteria (Jones, 1978). The fact that the enzyme reacts only slightly with Proto supports the notion that incorporation of Mg occurs prior to the methylation step.

2. Mg-PROTOPORPHYRIN MONOMETHYL ESTER TO BACTERIOCHLOROPHYLL *a*

a. Pyrroles Accumulated by Mutants. Exploitation of mutants to delineate the pathway of heme and chlorophyll synthesis was originally applied by Granick (1950a,b) with *Chlorella* mutants blocked at various stages of chlorophyll synthesis. Bacteria of the Rhodospirillaceae family, such as *Rp. sphaeroides*, have been used in similar work. These organisms are facultative phototrophs, and mutants lacking BChl can be grown aerobically. However, high aeration represses the formation of BChl, and expression of the mutant phenotype occurs only under conditions of oxygen limitation (Lascelles and Hatch, 1972).

Workers in Stanier's laboratory made the original observations of accumulation of pyrrole pigments in BChl mutants and identified Mg-2,4-divinylphaeoporphyrin *a*₅ (DV Pchlide) in addition to several Mg-free derivatives (Sistrom *et al.*, 1956). Such compounds are also found in the wild-type cells grown with 8-hydroxyquinoline (Jones, 1978). Richards and Lascelles (1969) identified a series of compounds accumulated by mutants of *Rp. sphaeroides* as: Mg-2,4-divinylpheoporphyrin *a*₅, 2-desvinyl-2-hydroxyethylchlorophyllide *a*, 2-desecetyl-2-hydroxyethylbacteriochlorophyllide *a*, bacteriochlorophyllide *a*, and phaeophorbide *a*. Excretion of the compounds into the medium was favored by Tween 80, which probably acted as a solubilizing agent. The sequence of intermediates thought to lead to BChl *a* is based largely on the excretion products of the various mutants (Fig. 20).

It is generally accepted that the Mg derivatives are the intermediates in BChl synthesis. Yet, Mg-free phaeophorbides have been frequently found among the products accumulated by mutants and also by wild-type *Rp. sphaeroides* treated with 8-hydroxyquinoline. These may be by-products derived from the corresponding Mg compounds. Alternatively, they could be precursors of bacteriopheophytin *a*, which is an integral part of the RCs in various photosynthetic bacteria (Feher and

Okamura, 1978; Thornber *et al.*, 1978; see Okamura *et al.*, Chapter 5, this volume).

The excretion of pigment-protein complexes by certain mutants has encouraged speculation about their role as "bound intermediates." A mutant of *Rs. rubrum* accumulated phaeoborbide *a* and 2-desvinyl-2-hydroxyethylphaeophorbide as a complex containing 49% protein, 11% lipid, and 3% carbohydrate (Oelze and Drews, 1971). In cultures of a mutant strain of *Rp. capsulata*, phytolated derivatives were identified in a complex containing protein (38%), fatty acids (13%), and carbohydrate (15.5%) (Drews, 1974). A small polypeptide (MW = 9,000) was found to be associated with pigments excreted by mutants of *Rp. sphaeroides* (Richards *et al.*, 1975). The "Phofil" mutant of this organism is phototrophically competent and forms BChl in addition to an extracellular complex containing 2-vinyl-4-ethylpheoporphyrin *a*₅ monomethyl ester, protein and phospholipid (Pradel and Clement-Metral, 1976). The kinetics of synthesis of BChl and of the complex in cultures of "Phofil" are consistent with a product-precursor relationship.

The status of these complexes as precursors of the functional forms of BChl in the appropriate membrane structure remains open. The complexes could arise artifactually by association of the pigment with precursors of the cell envelope and the presence of carbohydrate supports this possibility.

b. Enzymatic Steps. Knowledge of the enzymes of the pathway in bacteria is completely lacking, and it seems that *in vitro* systems from plant tissue are more amenable for such work. Problems of particular concern in the microbial system include the steps requiring addition or removal of hydrogen atoms; the hydrogen donor and acceptor systems are still unknown. The phytylation step is another area of major interest. It involves integration of the pyrrole pathway with the steps leading to the alkyl side-chain formation presumably from mevalonate. Also, this step seems to be of critical importance for the development of the intracytoplasmic membranes of the bacteria since mutants blocked at this step (and preceding steps) do not form this membrane system (Brown and Lascelles, 1972; Brown *et al.*, 1972).

VIII. Regulation of Bacteriochlorophyll Synthesis

Cohen-Bazire *et al.* (1957) made fundamental observations concerning the regulation of BChl and carotenoid formation in growing cultures of *Rp. sphaeroides* and *Rs. rubrum*: (a) under anaerobic conditions, pig-

ment synthesis varied inversely with the light intensity; (b) introduction of oxygen into cultures growing anaerobically in the light resulted in abrupt inhibition of pigment synthesis; and (c) only traces of pigment were formed by cells grown with high aeration, but the pigments were formed in the dark under conditions of limited aeration.

It is now known that the changes in pigment synthesis are accompanied by profound changes in the system of intracytoplasmic membranes (ICM), which are characteristic of the phototrophically grown organisms, and that BChl synthesis is interwoven with the formation of the ICM. Development of the membrane system in the photosynthetic bacteria has been discussed in depth by Kaplan (1978), Drews (1978), and I. Ohad and G. Drews, Chapter 5, Govindjee, Vol. II (1982); in this section, we shall consider only aspects pertaining to formation of BChl in *Rp. sphaeroides*.

A. Interaction of the Iron and Magnesium Branches of the Biosynthetic Pathway

Bacteriochlorophyll *a* is the major end product of the tetrapyrrole pathway in phototrophic cells of *Rp. sphaeroides*, exceeding hemes by 10- to 50-fold. Abrupt interruption of BChl synthesis, for example by introduction of oxygen, leads to a rapid readjustment of the overall rate of tetrapyrrole formation which permits continuing synthesis of hemes without even transient accumulation of intermediates. Such a rapid response indicates feedback control of ALA synthase. This enzyme is presumed to be rate-limiting for the overall biosynthetic path since addition of exogenous ALA results in the accumulation of PBG, porphyrins, hemes, and Mg-pyrroles (Lascelles and Hatch, 1969).

The intracellular concentration of heme may have a critical role in regulating the biosynthetic pathway by feedback inhibition by ALA synthase. Purified preparations of the enzyme from *Rp. sphaeroides* and from other sources are strongly inhibited by hemin at 1 μ M concentrations and the inhibition is reversible by dilution (Burnham, 1970; Lascelles, 1978). Reversibility of the inhibition fulfills a requirement to be expected of a physiological effector and there is additional *in vivo* evidence to support control of ALA synthase by heme. Thus, accumulation of porphyrins occurs under conditions of iron deficiency or when heme synthesis is prevented by *o*-phenanthroline. Excessive accumulation of intermediates also occurs in certain mutants with impairments in the heme biosynthetic pathway (Lascelles, 1975, 1978).

Acceptance of heme as a major factor in regulating ALA synthase raises the question of how such a control operates in response to termination of BChl synthesis. A simple working model invokes competition

between the Mg- and Fe-chelatases for the common substrate Proto. Inhibition of the Mg enzyme, for example by oxygen, could divert Proto to heme, raising the intracellular level to that necessary to inhibit the ALA synthase. Indirect evidence provides some support for this hypothesis. For example, the intracellular concentration of heme rises upon inhibition of BChl synthesis by aeration or by addition of inhibitors of protein synthesis (Lascelles, 1978). However, crucial information concerning the respective chelatase enzymes is required. For example, what are their relative sensitivities to oxygen and what are their affinities for Proto? In view of the limited knowledge of the chelatases, particularly Mg-chelatase, further speculation is unprofitable.

B. Coupling of Bacteriochlorophyll Synthesis with Protein and Lipid Synthesis

Synthesis of BChl is tightly coupled to protein synthesis as shown by the immediate cessation of pigment production upon addition of inhibitors of protein synthesis (Bull and Lascelles, 1963). Strict dependence upon synthesis of lipids is shown by similar experiments with cerulenin (Broglie and Niederman, 1979).

The proteins associated with the RC and antenna forms of BChl are those most directly concerned in the coupled synthesis; in phototrophic cells of *Rp. sphaeroides* they comprise 25% and 40–50%, respectively, of the total ICM proteins (Niederman and Gibson, 1978; Drews, 1978). The formation and/or assembly of these proteins apparently requires the complete, phytylated BChl molecule. They are not detectable in membranes or cytoplasm of mutant 8–17, which is blocked at the final phytylation step and which accumulates BChlide; nor are they found in mutants blocked at earlier stages of the Mg pathway (Takemoto and Lascelles, 1973). The obligatory link between synthesis of the RC and antenna proteins and BChl has been most clearly demonstrated with an ALA-requiring mutant of *Rp. sphaeroides* (Takemoto and Lascelles, 1973; Broglie and Niederman, 1979). When growing phototrophically with ALA and labeled amino acids, synthesis of pigment is accompanied by incorporation of the label into the various proteins of the ICM. However, upon withdrawal of ALA, BChl synthesis ceases, together with amino acid incorporation into the RC and antenna proteins, whereas formation of other membrane proteins continues.

C. Effects of Oxygen and Light Intensity

Cohen-Bazire *et al.* (1957) originally proposed that the redox state of components of the respiratory chain are critical in regulating BChl synthesis. This state could be influenced by electron flow to oxygen via the

terminal oxidases or by light-induced electron flux under phototrophic conditions. This proposal remains a useful working hypothesis. For example, the provision of reductant for the reductive steps in BChl synthesis could be influenced by the redox status of components of the respiratory chain. However, the reductive steps occur at the final stages of the biosynthetic pathway (Fig. 20), and the effects of oxygen or light involve the entire magnesium pathway. It now seems that components of the respiratory chain may not be *directly* involved in regulating BChl synthesis. Thus, formation of the pigment is inhibited by oxygen in mutants of *Rp. capsulata* with defects in the respiratory chain (Marrs and Gest, 1973).

The role of thiols, disulfides, and iron-sulfur proteins should be given serious consideration as effectors of enzyme activity. The inactivation of ALA synthase by aeration and its reactivation by thiol-disulfide interchange reactions has been discussed earlier and other key enzymes, for example Mg-chelatase, might be regulated in a similar fashion. Such speculations are presently justified by the discovery of the ferredoxin-thioredoxin system which appears to regulate the activity of enzymes in plant tissues.

In conclusion, thoughts cannot be translated into facts until progress has been made in defining the steps in BChl synthesis at the enzymic level.

IX. Synthesis of Phycobilins

The algal bile pigments are synthesized from ALA, as shown originally by Troxler and Bogorad (1966) in work with the unicellular rhodophyte *Cyanidium caldarium*. A mutant strain was found to excrete free phycocyanobilin (Fig. 10a) together with PBG and various porphyrins, when incubated with ALA. These observations raised the question of whether the linear tetrapyrrole was formed by cleavage of the tetrapyrrole ring structure as occurs in the formation of the bile pigments in the liver. Troxler and co-workers pursued this problem with wild-type and mutant strains of the rhodophyte. This organism has advantages for studies of biosynthesis, since it forms Chl *a* and phycobiliproteins upon exposure of dark-grown cells to light. In the dark, free phycocyanobilin accumulates in response to ALA (Troxler *et al.*, 1978). Cleavage of the tetrapyrrole ring was indicated by the demonstration of CO evolution as the cells formed phycocyanin in the light; CO was produced at the same rate and in stoichiometric amounts with the pigment (Troxler, 1972). In experiments with [5-¹⁴C]ALA in the dark, the specific activity of the CO

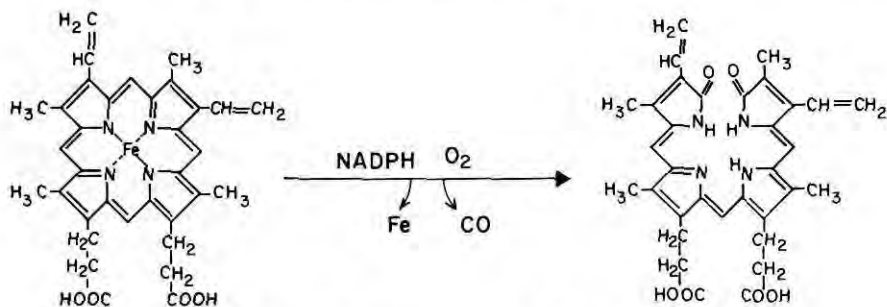

FIG. 21. Overall reaction catalyzed by heme oxygenase.

formed in association with the synthesis of phycocyanobilin was one-seventh that of the pigment, in accord with the theoretical value. Stoichiometric evolution of CO accompanying the synthesis of phycocyanin has also been observed in cultures of cyanobacteria (Troxler and Dokos, 1973). Extensive metabolism has precluded the use of ALA as a precursor in studies of phycobilin synthesis by the prokaryotes (Troxler and Brown, 1975).

Further insight into the cleavage mechanism was shown by the incorporation of $^{18}\text{O}_2$ into phycocyanobilin by cultures of *Cyanidium caldarium* (Troxler *et al.*, 1979). Degradation of the labeled pigment indicated that ring cleavage occurred by a similar mechanism to that found in animal tissues, which converts heme to biliverdin. In the liver, this reaction is catalyzed by heme oxygenase which requires oxygen and NADPH (Fig. 21). This activity has not been demonstrated in the algae, so the question of the tetrapyrrole precursor to the algal pigments remains open.

X. Formation of Prenyl lipids (Including Carotenoids)

Prenyl lipids make up about 25–30% of the total lipid pool of thylakoid membranes. They include the carotenoids which are pure prenyl lipids and the mixed prenyl lipids such as the prenyl quinones (Lichtenthaler, 1979). During greening the thylakoid membranes accumulate significant quantities of carotenoids namely: β -carotene, lutein, violaxanthin, neoxanthin, and very small amounts of lutein epoxide (see, e.g., Rebeiz, 1968a,b). Carotenoids have also been found in the chloroplast envelope where some carotenoid biosynthesis appears to take place (Siefermann-Harms *et al.*, 1978; Costes *et al.*, 1979).

Thylakoid membranes also contain several prenylquinones (plasto-

quinone-9, phyloquinone K₁, α -tocoquinone + α -tocopherol) which appear to be electron carriers of the photosynthetic electron transport chain (Lichtenthaler, 1979). (For a discussion on quinones in both plants and bacteria, see Cramer and Crofts, Chapter 9, this volume.)

All prenyllipids appear to be derived directly or indirectly from geranylgeranyl-*p-p*. Since space limitations preclude a detailed discussion of these important constituents of the thylakoid membranes the reader is referred to some specialized reviews (Britton, 1976; Lichtenthaler, 1977, 1979; Porter and Spurgeon, 1979).

It is hoped that during the coming years the chemistry and the function of the various species of LW and SW Chl *a* and *b* will become established. Perhaps, the chemical nature and distribution of various BChls will also be examined in more detail. The material discussed in this chapter forms a natural bridge with the discussions on the biosynthesis of membranes by I. Ohad and G. Drews in Chapter 5 of Volume II (Govindjee, 1982). In our opinion the understanding of the chemical structure of the photosynthetic pigments, discussed in this chapter, is of paramount importance for a better understanding of photosynthesis which constitutes the subject of the present two volumes.

REFERENCES

- Al-Hazimi, H. M. G., Jackson, A. H., and Ryder, D. J. (1976). *J. Chem. Soc., Chem. Commun.* pp. 188-189.
- Anderson, J. M. (1975). *Biochim. Biophys. Acta* **416**, 191-235.
- Aronoff, S., and Kwok, E. (1977). *Can. J. Biochem.* **55**, 1091-1095.
- Barnard, G. F., Itor, R., Hohberger, L. H., and Shemin, D. (1977). *J. Biol. Chem.* **252**, 8965-8974.
- Barrett, J., and Jones, O. T. G. (1978). *Biochem. J.* **174**, 277-281.
- Bartsch, R. G. (1978). In "The Photosynthetic Bacteria" (R. K. Clayton and W. R. Sistrom, eds.), pp. 249-279. Plenum, New York.
- Battersby, A. R. (1978). *Ciba Found. Symp. [N.S.]* **53**, 25-51.
- Battersby, A. R., and McDonald, E. (1975). In "Porphyrins and Metalloporphyrins" (K. M. Smith, ed.), pp. 61-122. Elsevier, Amsterdam.
- Bazzaz, M. B. (1981). *Photobiochem. Photobiophys.* **2**, 199-207.
- Bazzaz, M. B., and Rebeiz, C. A. (1978). *Biochim. Biophys. Acta* **504**, 310-323.
- Beale, S. I. (1970). *Plant Physiol.* **45**, 504-506.
- Beale, S. I. (1971). *Plant Physiol.* **48**, 316-319.
- Beale, S. I. (1978). *Annu. Rev. Plant Physiol.* **29**, 95-120.
- Beale, S. I., and Castelfranco, P. A. (1974a). *Plant Physiol.* **53**, 291-296.
- Beale, S. I., and Castelfranco, P. A. (1974b). *Plant Physiol.* **53**, 297-303.
- Beale, S. I., Gough, S. P. Q., and Granick, S. (1975). *Proc. Natl. Acad. Sci. U.S.A.* **72**, 2719-2723.
- Bélanger, F. C., and Rebeiz, C. A. (1979). *Biochem. Biophys. Res. Commun.* **88**, 365-372.
- Bélanger, F. C., and Rebeiz, C. A. (1980a). *J. Biol. Chem.* **255**, 1266-1272.

- Bélanger, F. C., and Rebeiz, C. A. (1980b). *Plant Sci. Lett.* **18**, 343-350.
- Bélanger, F. C., and Rebeiz, C. A. (1980c). *Biochemistry* **19**, 4875-4883.
- Bélanger, F. C., and Rebeiz, C. A. (1981). *Plant Physiol.* **67**, S-268.
- Bélanger, F. C., and Rebeiz, C. A. (1982). *J. Biol. Chem.* **257**, 1360-1371.
- Bélanger, F. C., Duggan, J. X., and Rebeiz, C. A. (1982). *J. Biol. Chem.* **257**, 4849-4858.
- Benz, J., and Rüdiger, W. (1981). *Z. Naturforsch* **36C**, 51-57.
- Boardman, N. K. (1966). In "The Chlorophylls" (L. P. Vernon and G. R. Seely, eds.), pp. 437-479. Academic Press, New York.
- Bogorad, L. (1955). *Science* **121**, 878-879.
- Bogorad, L. (1958a). *J. Biol. Chem.* **233**, 501-509.
- Bogorad, L. (1958b). *J. Biol. Chem.* **233**, 510-515.
- Bogorad, L. (1966). In "The Chlorophylls" (L. P. Vernon and G. R. Seely, eds.), pp. 481-510. Academic Press, New York.
- Bogorad, L. (1975). *Annu. Rev. Plant Physiol.* **26**, 369-401.
- Bogorad, L., and Granick, S. (1953). *Proc. Natl. Acad. Sci. U.S.A.* **39**, 1176-1188.
- Britton, G. (1976). *Pure Appl. Chem.* **47**, 223-236.
- Brogie, R. M., and Niederman, R. A. (1979). *J. Bacteriol.* **138**, 788-798.
- Brown, A. E., and Lascelles, J. (1972). *Plant Physiol.* **50**, 747-749.
- Brown, A. E., Eislering, F. A., and Lascelles, J. (1972). *Plant Physiol.* **50**, 743-746.
- Brown, J. S. (1977). *Photochem. Photobiol.* **26**, 319-326.
- Bull, M. J., and Lascelles, J. (1963). *Biochem. J.* **87**, 15-28.
- Burnham, B. F. (1970). In "Methods in Enzymology" (D. B. McCormick and L. D. Wright, eds.), Vol. 18, Part A, pp. 195-200. Academic Press, New York.
- Burrell, J. W. K., Garwood, R. F., Jackman, L. M., Oskay, E., and Weedon, B. C. L. (1966). *J. Chem. Soc. C*, p. 2144.
- Canaani, O. D., and Sauer, K. (1977). *Plant Physiol.* **60**, 422-429.
- Castelfranco, P. A., and Jones, O. T. G. (1975). *Plant Physiol.* **55**, 485-490.
- Castelfranco, P. A., and Schwarcz, S. (1978). *Arch. Biochem. Biophys.* **186**, 365-375.
- Castelfranco, P. A., Weinstein, J. D., Schwarcz, S., Pardo, A. D., and Wezelman, B. E. (1979). *Arch. Biochem. Biophys.* **192**, 592-598.
- Cavaleiro, J. A. S., Kenner, G. W., and Smith, K. V. (1974). *J. Chem. Soc., Perkin Trans. 1*, pp. 1188-1194.
- Chen, S. T. C., and Miller, G. W. (1974). *Plant Cell Physiol.* **15**, 993-1005.
- Clement-Metral, J. D. (1979). *FEBS Lett.* **101**, 116-120.
- Clement-Metral, J. D., and Fanica-Gaignier, M. (1975). *Eur. J. Biochem.* **59**, 73-77.
- Cohen, C. E., and Rebeiz, C. A. (1978). *Plant Physiol.* **61**, 824-829.
- Cohen, C. E., and Rebeiz, C. A. (1981). *Plant Physiol.* **67**, 98-103.
- Cohen, C. E., Bazzaz, M. B., Fullett, S. H., and Rebeiz, C. A. (1977). *Plant Physiol.* **60**, 743-746.
- Cohen-Bazire, G., Sistrom, W. R., and Stanier, R. Y. (1957). *J. Cell. Comp. Physiol.* **49**, 25-68.
- Costes, C., Burghoffer, C., Joyard, J., Block, M., and Douce, R. (1979). *FEBS Lett.* **103**, 17-21.
- Dailey, H. A. (1977). *J. Bacteriol.* **132**, 302-307.
- Dailey, H. A., and Lascelles, J. (1977). *J. Bacteriol.* **129**, 815-820.
- Davies, R. C., and Neuberger, A. (1979). *Biochem. J.* **177**, 649-659.
- Díaz, L., Frydman, R. B., Valasinas, A., and Frydman, B. (1979). *J. Am. Chem. Soc.* **101**, 2710-2716.
- Drews, G. (1974). *Arch. Microbiol.* **100**, 397-407.
- Drews, G. (1978). *Curr. Top. Bioenerg.* **8**, 161-207.

- Duggan, J. X., and Gassman, M. (1974). *Plant Physiol.* **53**, 206–215.
- Duggan, J. X., and Rebeiz, C. A. (1982a). *Biochim. Biophys. Acta* **714**, 248–260.
- Duggan, J. X., and Rebeiz, C. A. (1982b). *Plant Sci. Lett.* **24**, 27–37.
- Duggan, J. X., and Rebeiz, C. A. (1982c). *Plant Sci. Lett.* (in press).
- Dujardin, E., and Sironval, C. (1970). *Photosynthetica* **4**, 129–138.
- Elder, G. H., Evans, J. O., Jackson, J. R., and Jackson, A. H. (1978). *Biochem. J.* **169**, 215–223.
- Ellsworth, R. K., and Aronoff, S. (1969). *Arch. Biochem. Biophys.* **130**, 374–388.
- Ellsworth, R. K., and Hervish, P. V. (1975). *Photosynthetica* **9**, 125–139.
- Ellsworth, R. K., and Hsing, A. S. (1973). *Biochim. Biophys. Acta* **313**, 119–129.
- Ellsworth, R. K., and Hsing, A. S. (1974). *Photosynthetica* **8**, 228–234.
- Ellsworth, R. K., and Murphy, S. J. (1979). *Photosynthetica* **13**, 392–400.
- Ellsworth, R. K., and St. Pierre, L. A. (1975). *Photosynthetica* **9**, 340–342.
- Ellsworth, R. K., and St. Pierre, M. E. (1976). *Photosynthetica* **10**, 291–301.
- Evans, N., Games, D. E., Jackson, A. H., and Matlin, S. A. (1975). *J. Chromatogr.* **115**, 325–333.
- Evstigneev, W. B., Gavriola, W. A., and Krasnovskii, A. A. (1949). *Dokl. Akad. Nauk SSSR* **66**, 1133–1136.
- Fajer, J., and Davis, M. S. (1980). In "The Porphyrins" (D. Dolphin, ed.), Vol. 4B, pp. 197–256. Academic Press, New York.
- Feher, G., and Okamura, M. Y. (1978). In "The Photosynthetic Bacteria" (R. K. Clayton and W. R. Sistrom, eds.), pp. 349–386. Plenum, New York.
- Ficken, G. E., Johns, R. B., and Linstead, R. P. (1956). *J. Chem. Soc.*, pp. 2272–2280.
- Fischer, F. G., and Löwenberg, U. K. (1929). *Justus Liebigs Ann. Chem.* **475**, 183–204.
- Fischer, H., and Orth, H. (1937). "Die Chemie des Pyrrols" Vol. 2, Part I. Akad. Verlagsges., Leipzig.
- Fischer, H., and Schwerdtel, E. (1928). *J. Physiol. Chem.* **175**, 248–260.
- Fischer, H., and Stern, A. (1935). *Justus Liebigs Ann. Chem.* **520**, 88–98.
- Fischer, H., and Stern, A. (1940). "Die Chemie des Pyrrols" Vol. 2, Part II. Akad. Verlagsges., Leipzig.
- Fischer, H., and Wenderoth, H. (1939). *Justus Liebigs Ann. Chem.* **537**, 170–177.
- Fleming, I. (1968). *J. Chem. Soc. C*, pp. 2765–2770.
- Fluhr, R., Harel, E., Klein, S., and Meller, E. (1975). *Plant Physiol.* **56**, 497–501.
- Fong, F. K. (1975). *Appl. Phys.* **6**, 151–166.
- Ford, S. H., and Friedmann, H. C. (1979). *Biochim. Biophys. Acta* **569**, 153–158.
- Freed, S., and Sancier, K. M. (1951). *Science* **114**, 275–276.
- Freed, S., and Sancier, K. M. (1952). *Science* **116**, 175–176.
- Freed, S., and Sancier, K. M. (1954). *J. Am. Chem. Soc.* **76**, 198–205.
- Freyssinet, G., Rebeiz, C. A., Fenton, J. F., Khanna, R., and Govindjee (1980). *Photobiochem. Photobiophys.* **1**, 203–212.
- Frydman, B., and Frydman, R. B. (1975). *Acc. Chem. Res.* **8**, 201–208.
- Frydman, R. B., Valasinas, A., and Frydman, B. (1973a). *Biochemistry* **12**, 80–85.
- Frydman, R. B., Tomaro, M. L., Wanschelbaum, A., and Andersen, E. M. (1973b). *Biochemistry* **12**, 5253–5262.
- Frydman, R. B., Levy, E. S., Valasinas, A., and Frydman, B. (1978). *Biochemistry* **17**, 110–120.
- Frydman, R. B., Tomaro, M. L., and Frydman, B. (1979). *Phytochemistry* **18**, 1119–1123.
- Games, D. E., Jackson, A. H. and Jackson, J. R. (1976). *J. Chem. Soc., Chem. Commun.* pp. 187–188.
- Garrard, W. T. (1972). *J. Biol. Chem.* **247**, 5935–5943.

- Gassman, M., and Duggan, J. (1975). *Proc. Int. Congr. Photosynth.*, 3rd, 1974 pp. 2105-2113.
- Gassman, M., Pluscec, J., and Bogorad, L. (1968). *Plant Physiol.* **43**, 1411-1414.
- Gassman, M., Duggan, J. X., Stillman, L. C., Vicek, L. M., Castelfranco, P. A., and Wezelman, B. (1978). In "Chloroplast Development" (G. Akoyunoglou and J. H. Argyroudi-Akoyunoglou, eds.), pp. 167-181. Elsevier/North Holland Biomedical Press, Amsterdam.
- Gibson, K. D., Laver, W. D., and Neuberger, A. (1958). *Biochem. J.* **61**, 618-629.
- Gibson, K. D., Neuberger, A., and Tait, G. H. (1963). *Biochem. J.* **88**, 325-334.
- Gloe, A., Pfennig, N., Brockmann, H., Jr., and Trowitzsch, W. (1975). *Arch. Microbiol.* **102**, 103-109.
- Gollub, E. G., Liu, K. P., Dayan, J., Adlersberg, M., and Sprinson, D. B. (1977). *J. Biol. Chem.* **252**, 2846-2854.
- Gorchein, A. (1972). *Biochem. J.* **127**, 97-106.
- Gorchein, A. (1973). *Biochem. J.* **134**, 833-845.
- Gough, S. P., and Kannagara, C. G. (1977). *Carlsberg Res. Commun.* **42**, 459-464.
- Govindjee, ed. (1982). "Photosynthesis: Development, Carbon Metabolism, and Plant Productivity" Vol. II. Academic Press, New York.
- Govindjee, and Govindjee, R. (1975). In "Bioenergetics of Photosynthesis" (Govindjee, ed.), pp. 1-49. Academic Press, New York.
- Granick, S. (1948a). *J. Biol. Chem.* **172**, 717-727.
- Granick, S. (1948b). *J. Biol. Chem.* **175**, 333-342.
- Granick, S. (1950a). *Harvey Lect.* **44**, 220-245.
- Granick, S. (1950b). *J. Biol. Chem.* **183**, 713-730.
- Granick, S. (1954). *Science* **120**, 1105-1106.
- Granick, S. (1959). *Plant Physiol.* **54**, Suppl., XVIII.
- Granick, S. (1961). *J. Biol. Chem.* **236**, 1168-1172.
- Granick, S., and Beale, S. I. (1978). *Adv. Enzymol.* **46**, 33-203.
- Granick, S., and Mauzerall, D. (1958). *Fed. Proc., Fed. Am. Soc. Exp. Biol.* **17**, 233.
- Granick, S., and Mauzerall, D. (1961). In "Metabolic Pathways" (D. M. Greenberg, ed.), pp. 525-616. Academic Press, New York.
- Griffiths, W. T. (1974). *FEBS Lett.* **46**, 301-304.
- Griffiths, W. T. (1978). *Biochem. J.* **186**, 267-278.
- Harel, E., Meller, E., and Rosenberg, M. (1978). *Phytochemistry* **17**, 1277-1280.
- Hayasaka, S., and Tuboi, S. (1974). *J. Biochem. (Tokyo)* **76**, 157-168.
- Henningsen, K. W., Thorne, S. W., and Boardman, N. K. (1974). *Plant Physiol.* **53**, 419-425.
- Higuchi, M., and Bogorad, L. (1974). *Ann. N. Y. Acad. Sci.* **244**, 401-418.
- Hochapfel, A., Berchet, D., and Viovy, R. (1970). *Biochim. Biophys. Acta* **222**, 180-190.
- Horton, P., and Leech, R. M. (1972). *FEBS Lett.* **26**, 277-280.
- Horton, P., and Leech, R. M. (1975). *Plant Physiol.* **56**, 113-120.
- Hsu, W. P., and Miller, G. W. (1970). *Biochem. J.* **117**, 215-220.
- Hucklesby, D. B., James, D. M., Banwell, M. J., and Hewitt, E. J. (1978). *Phytochemistry* **15**, 599-603.
- Hynninen, P. (1979). *J. Chromatogr.* **175**, 75-88.
- Inoue, I., Oyama, H., and Tuboi, S. (1979). *J. Biochem. (Tokyo)* **86**, 477-482.
- Jackson, A. H. (1977). *Endeavour* **1**, 75-82.
- Jackson, A. H., Ferramola, A. M., Sancovich, H. A., Evans, N., Matlin, S. A., Ryder, D. J., and Smith, S. G. (1976a). *Ann. Clin. Res.* **8**, Suppl. 17, 64-69.
- Jackson, A. H., Sancovich, H. A., Ferramola, A. M., Evans, N., Games, D. E., and Matlin, S. A. (1976b). *Philos. Trans. R. Soc. London, Ser. B* **273**, 191-206.

- Jackson, A. H., Elder, G. H., and Smith, S. G. (1978). *Int. J. Biochem.* **9**, 877-882.
- Jacobs, N. J., and Jacobs, J. M. (1975). *Biochem. Biophys. Res. Commun.* **65**, 435-441.
- Jacobs, N. J., and Jacobs, J. M. (1976). *Biochim. Biophys. Acta* **448**, 1-9.
- Jacobs, N. J., and Jacobs, J. M. (1977). *Biochim. Biophys. Acta* **459**, 141-144.
- Jacobs, N. J., and Jacobs, J. M. (1978). *Biochim. Biophys. Acta* **544**, 540-546.
- Jacobs, N. J., and Jacobs, J. M. (1979). *Arch. Biochem. Biophys.* **197**, 396-403.
- Jones, M. S., and Jones, O. T. G. (1970). *Biochem. J.* **119**, 453-462.
- Jones, O. T. G. (1963). *Biochem. J.* **89**, 182-189.
- Jones, O. T. G. (1978). In "The Photosynthetic Bacteria" (R. K. Clayton and W. R. Sistrom, eds.), pp. 751-777. Plenum, New York.
- Jordan, P. M., and Seehra, J. S. (1979). *FEBS Lett.* **104**, 364-366.
- Jordan, P. M., and Shemin, D. (1973). *J. Biol. Chem.* **248**, 1019-1024.
- Jurgenson, J. E., Beale, S. I., and Troxler, R. F. (1976). *Biochem. Biophys. Res. Commun.* **69**, 149-157.
- Kahn, A., Boardman, N. K., and Thorne, S. W. (1970). *J. Mol. Biol.* **48**, 85-101.
- Kaplan, S. (1978). In "The Photosynthetic Bacteria" (R. K. Clayton and W. R. Sistrom, eds.), pp. 809-839. Plenum, New York.
- Kasemir, H. (1979). *Cell Biol., Int. Rep.* **3**, 197-214.
- Katz, J. J., Norman, G. D., Svec, W. A., and Strain, H. H. (1968). *J. Am. Chem. Soc.* **90**, 6841-6845.
- Katz, J. J., Norris, J. R., Shipman, L. L., Thurnauer, M. C., and Wasielewski, M. R. (1978). *Annu. Rev. Biophys. Bioeng.* **7**, 393-425.
- Keyhani, J., and Keyhani, E. (1978). *FEBS Lett.* **93**, 271-274.
- Kikuchi, G., Kumar, A., Talmage, P., and Shemin, D. (1958). *J. Biol. Chem.* **233**, 1214-1219.
- Kipe-Nolt, J. A., and Stevens, S. E., Jr. (1979). *J. Bacteriol.* **137**, 146-152.
- Kipe-Nolt, J. A., Stevens, S. E., Jr., and Stevens, C. L. R. (1978). *J. Bacteriol.* **135**, 286-288.
- Kirk, J. T. O. (1970). *Annu. Rev. Plant Physiol.* **21**, 11-42.
- Klein, O., and Senger, H. (1978). *Plant Physiol.* **62**, 10-13.
- Klein, S., Katz, E., and Neeman, E. (1977). *Plant Physiol.* **60**, 335-338.
- Koski, V. M., and Smith, J. H. C. (1948). *J. Am. Chem. Soc.* **70**, 3558-3562.
- Lascelles, J. (1975). *Ann. N. Y. Acad. Sci.* **244**, 334-347.
- Lascelles, J. (1978). In "The Photosynthetic Bacteria" (R. K. Clayton and W. R. Sistrom, eds.), pp. 795-808. Plenum, New York.
- Lascelles, J., and Hatch, T. P. (1969). *J. Bacteriol.* **98**, 712-720.
- Lascelles, J., and Hatch, T. P. (1972). In "Methods in Enzymology" (A. San Pietro, ed.), Vol. 24, Part B, pp. 407-411. Academic Press, New York.
- Lascelles, J., Rittenberg, B., and Clark-Walker, G. D. (1969). *J. Bacteriol.* **97**, 455-456.
- Lichtenthaler, H. K. (1977). In "Lipids and Lipid Polymers in Higher Plants" (M. Tevini and H. K. Lichtenthaler, eds.), pp. 221-258. Springer-Verlag, Berlin and New York.
- Lichtenthaler, H. K. (1979). In "Advances in the Biochemistry and Physiology of Plant Lipids" (L. A. Appelquist and C. Liljenberg, eds.), pp. 57-78. Elsevier, Amsterdam.
- Liljenberg, C. (1974). *Physiol. Plant.* **32**, 208-213.
- Little, H. N., and Jones, O. T. G. (1976). *Biochem. J.* **156**, 309-314.
- Livingston, R., and Weil, S. (1952). *Nature (London)* **170**, 750-751.
- Loeffler, J. E. (1955). *Year Book—Carnegie Inst. Washington* **54**, 159-160.
- McCarthy, S. A., and Rebeiz, C. A. (1980). *Plant Physiol.* **66**, 142-146.
- McCarthy, S. A., and Rebeiz, C. A. (1982). In preparation.
- McCarthy, S. A., Bélanger, F. C., and Rebeiz, C. A. (1981). *Biochemistry* **20**, 5080-5087.
- McCarthy, S. A., Mattheis, J. R., and Rebeiz, C. A. (1982). *Biochemistry* **21**, 242-247.

- Mapleston, R. E., and Griffiths, W. T. (1978). *FEBS Lett.* **92**, 168–172.
- Marrs, B., and Gest, H. (1973). *J. Bacteriol.* **114**, 1052–1057.
- Mattheis, J. R., and Rebeiz, C. A. (1977a). *J. Biol. Chem.* **252**, 4022–4024.
- Mattheis, J. R., and Rebeiz, C. A. (1977b). *J. Biol. Chem.* **252**, 8347–8349.
- Mattheis, J. R., and Rebeiz, C. A. (1977c). *Arch. Biochem. Biophys.* **184**, 189–196.
- Mattheis, J. R., and Rebeiz, C. A. (1978). *Photochem. Photobiol.* **28**, 55–60.
- Mauzerall, D., and Granick, S. (1958). *J. Biol. Chem.* **232**, 1141–1162.
- Mendy, D. F., Tomaro, M. L., and Frydman, R. B. (1979). *Phytochemistry* **18**, 1427–1431.
- Michel-Wolwertz, M. R., and Sironval, C. (1965). *Biochim. Biophys. Acta* **94**, 330–343.
- Mori, M., and Sano, S. (1972). *Biochim. Biophys. Acta* **264**, 252–258.
- Murphy, M. J., and Siegel, L. M. (1973). *J. Biol. Chem.* **248**, 6911–6919.
- Murphy, M. J., Siegel, L. M., Tove, S. R., and Kamin, H. (1974). *Proc. Natl. Acad. Sci. U.S.A.* **71**, 612–616.
- Nandi, D. L. (1978). *J. Biol. Chem.* **253**, 8872–8877.
- Nandi, D. L., and Shemin, D. (1968). *J. Biol. Chem.* **243**, 1236–1242.
- Nandi, D. L., and Shemin, D. (1977). *J. Biol. Chem.* **252**, 2278–2280.
- Neuberger, A., and Tait, G. H. (1964). *Biochem. J.* **90**, 607–616.
- Neve, R. A., and Labbe, R. F. (1956). *J. Am. Chem. Soc.* **78**, 691–692.
- Niederman, R. A., and Gibson, K. D. (1978). In "The Photosynthetic Bacteria" (R. K. Clayton and W. R. Sistrom, eds.), pp. 79–118. Plenum, New York.
- Oelze, J., and Drews, G. (1971). *Arch. Microbiol.* **73**, 19–33.
- Oelze-Karow, H., and Mohr, H. (1978). *Photochem. Photobiol.* **27**, 189–193.
- Oelze-Karow, H., Kasemir, H., and Mohr, H. (1978). In "Chloroplast Development" (G. Akoyunoglou and J. H. Argyroudi-Akoyunoglou, eds.), pp. 787–792. Elsevier, North-Holland Biomedical Press, Amsterdam.
- Oh-hama, T., and Senger, H. (1978). *Plant Cell Physiol.* **19**, 1295–1299.
- Olson, J. M. (1978). In "The Photosynthetic Bacteria" (R. K. Clayton and W. R. Sistrom, eds.), pp. 161–178. Plenum, New York.
- Oyama, H., and Tuboi, S. (1979). *J. Biochem. (Tokyo)* **86**, 483–489.
- Parrs, R. J., and Lascelles, J. (1968). *Biochem. J.* **108**, 343–348.
- Pennington, F. C., Boyd, S. D., Horton, H., Taylor, S. W., Wulf, D. G., Katz, J. J., and Strain, H. H. (1967). *J. Am. Chem. Soc.* **89**, 3871–3875.
- Pfennig, N. (1978). In "The Photosynthetic Bacteria" (R. K. Clayton and W. R. Sistrom, eds.), pp. 3–27. Plenum, New York.
- Pierson, B. K., and Castenholz, R. W. (1978). In "The Photosynthetic Bacteria" (R. K. Clayton and W. R. Sistrom, eds.), pp. 179–197. Plenum, New York.
- Pordo, A. D., Chereskin, B. M., Castelfranco, P. A., Franceschi, V. R., and Wezelman, B. E. (1980). *Plant Physiol.* **65**, 956–960.
- Porter, J. W., and Spurgeon, S. L. (1979). *Pure Appl. Chem.* **51**, 609–622.
- Poulson, R. (1976). *J. Biol. Chem.* **251**, 3730–3733.
- Poulson, R., and Polglase, W. J. (1974). *J. Biol. Chem.* **249**, 6367–6371.
- Poulson, R., and Polglase, W. J. (1975). *J. Biol. Chem.* **250**, 1269–1274.
- Pradel, J., and Clement-Metral, J. D. (1976). *Biochim. Biophys. Acta* **430**, 253–264.
- Price, L., and Klein, W. H. (1961). *Plant Physiol.* **36**, 733–735.
- Radmer, R. J., and Bogorad, L. (1967). *Plant Physiol.* **42**, 463–465.
- Rebeiz, C. A. (1968a). *Magon, Ser. Sci.* **21**, 1–25.
- Rebeiz, C. A. (1968b). *Magon, Ser. Sci.* **23**, 1–10.
- Rebeiz, C. A., and Castelfranco, P. A. (1971a). *Plant Physiol.* **47**, 24–32.
- Rebeiz, C. A., and Castelfranco, P. A. (1971b). *Plant Physiol.* **47**, 33–37.
- Rebeiz, C. A., and Castelfranco, P. A. (1973). *Annu. Rev. Plant Physiol.* **24**, 129–172.

- Rebeiz, C. A., Yaghi, M., Abou-Haidar, M., and Castelfranco, P. A. (1970). *Plant Physiol.* **46**, 57-63.
- Rebeiz, C. A., Larson, S., Weier, T. E., and Castelfranco, P. A. (1973a). *Plant Physiol.* **51**, 651-659.
- Rebeiz, C. A., Crane, J. C., Nishijima, C., and Rebeiz, C. (1973b). *Plant Physiol.* **51**, 660-666.
- Rebeiz, C. A., Mattheis, J. R., Smith, B. B., Rebeiz, C. C., and Dayton, D. F. (1975a). *Arch. Biochem. Biophys.* **166**, 446-465.
- Rebeiz, C. A., Smith, B. B., Mattheis, J. R., Rebeiz, C. C., and Dayton, D. F. (1975b). *Arch. Biochem. Biophys.* **167**, 351-365.
- Rebeiz, C. A., Mattheis, J. R., Smith, B. B., Rebeiz, C. C., and Dayton, D. F. (1975c). *Arch. Biochem. Biophys.* **171**, 549-567.
- Rebeiz, C. A., Smith, B. B., Mattheis, J. R., Cohen, C. E., and McCarthy, S. A. (1978). In "Chloroplast Development" (G. Akoyunoglou and J. H. Argyroudi-Akoyunoglou, eds.), pp. 59-76. Elsevier/North-Holland Biomedical Press, Amsterdam.
- Rebeiz, C. A., Bélanger, F., Cohen, C. E., and McCarthy, S. (1979). *Ill. Res.* **21**, 3-4.
- Rebeiz, C. A., Bélanger, F. C., Freyssinet, G., and Saab, D. B. (1980). *Biochim. Biophys. Acta* **590**, 234-247.
- Rebeiz, C. A., Bélanger, F. C., McCarthy, S. A., Freyssinet, G., Duggan, J. X., Wu, S. M., and Mattheis, J. R. (1981). *Photosynthesis. Proc. Int. Congr. Photosynth., 5th, 1980* **5**, 197-212.
- Richards, W. R., and Lascelles, J. (1969). *Biochemistry* **3**, 3473-3482.
- Richards, W. R., Wallace, R. B., Tsao, M. S., and Ho, E. (1975). *Biochemistry* **14**, 5554-5560.
- Sandy, J. D., Davies, R. C., and Neuberger, A. (1975). *Biochem. J.* **150**, 245-257.
- Sano, S. (1966). *J. Biol. Chem.* **241**, 5276-5283.
- Sano, S., and Granick, S. (1961). *J. Biol. Chem.* **236**, 1173-1180.
- Saunders, V. A., and Jones, O. T. G. (1974). *Biochim. Biophys. Acta* **333**, 439-445.
- Schedel, M., Vanselow, M., and Trüper, H. G. (1979). *Arch. Microbiol.* **121**, 29-36.
- Schoch, S., Lampert, U., and Rüdiger, W. (1977). *Z. Pflanzenphysiol.* **83**, 427-436.
- Schwartzbach, S. D., Schiff, J. A., and Klein, S. (1976). *Planta* **131**, 1-9.
- Scott, A. I., Ho, K. S., Kajiware, M., and Takahashi, T. (1976). *J. Am. Chem. Soc.* **98**, 1589-1591.
- Seely, G. R. (1966). In "The Chlorophylls" (L. P. Vernon and G. R. Seely, eds.), pp. 67-109. Academic Press, New York.
- Senger, H., Klein, O., Dörnemann, D., and Porra, R. J. (1980). In "The Blue Light Syndrome" (H. Senger, ed.) pp. 541-551. Springer-Verlag, Berlin.
- Shemin, D. (1968). In "Porphyrin and Related Compounds" (T. W. Goodwin, ed.), pp. 75-89. Academic Press, New York.
- Shemin, D. (1976). *Philos. Trans. R. Soc. London, Ser. B* **273**, 109-115.
- Shemin, D., and Russell, C. S. (1953). *J. Am. Chem. Soc.* **75**, 4873-4875.
- Shibata, K. (1957). *J. Biochem. (Tokyo)* **44**, 147-172.
- Shibata, H., and Ochiai, H. (1977). *Plant Cell Physiol.* **18**, 421-429.
- Shlyk, A. A. (1971). *Annu. Rev. Plant Physiol.* **22**, 169-184.
- Siefermann-Horms, D., Joyard, J., and Douce, R. (1978). *Plant Physiol.* **61**, 530-533.
- Singhal, G. S., Williams, W. P., and Rabinowitch, E. (1968). *J. Phys. Chem.* **72**, 3941-3951.
- Sisler, E. C., and Klein, W. H. (1963). *Physiol. Plant.* **16**, 315-322.
- Sistrion, W. R., Griffith, M., and Stanier, R. Y. (1956). *J. Cell. Comp. Physiol.* **48**, 459-464.
- Smith, B. B. (1978). Ph.D. Thesis, University of Illinois, Urbana.
- Smith, B. B., and Rebeiz, C. A. (1977a). *Photochem. Photobiol.* **26**, 527-532.
- Smith, B. B., and Rebeiz, C. A. (1977b). *Arch. Biochem. Biophys.* **180**, 178-185.

- Smith, B. B., and Rebeiz, C. A. (1979). *Plant Physiol.* **63**, 227–231.
- Smith, J. H. C., and French, C. S. (1963). *Annu. Rev. Plant Physiol.* **14**, 181–224.
- Smith, J. H. C., and Kupke, D. W. (1956). *Nature (London)* **178**, 751–752.
- Smith, J. H. C., and Young, V. M. K. (1956). In "Radiation Biology" (A. Hollaender, ed.), Vol. 3, p. 393. McGraw-Hill, New York.
- Smith, S. G., Jackson, A. H., and Jackson, T. R. (1976a). *Ann. Clin. Res.* **8**, Suppl. 7, 53–55.
- Smith, S. G., Ferramola, A. M., Sancovich, M. A., Evans, N., Matlin, S. A., Ryder, D. I., and Jackson, A. H. (1976b). *Ann. Clin. Res.* **8**, Suppl. 17, 89–91.
- Stevens, S. E., and Kipe-Nolt, J. A. (1979). *Proc. Int. Congr. Photosyn. Prokaryotes, 3rd, 1979* **B35**.
- Stoll, A., and Wiedemann, E. (1952). *Fortschr. Chem. Forsch.* **2**, 538–608.
- Strain, H. H., and Svec, W. A. (1966). In "The Chlorophylls" (L. P. Vernon and G. R. Seely, eds.), pp. 21–66. Academic Press, New York.
- Tait, G. H. (1972). *Biochem. J.* **128**, 1159–1169.
- Tait, G. H., and Gibson, K. D. (1961). *Biochim. Biophys. Acta* **52**, 614–616.
- Takemoto, J., and Lascelles, J. (1973). *Proc. Natl. Acad. Sci. U.S.A.* **70**, 799–803.
- Thorner, J. P. (1975). *Annu. Rev. Plant Physiol.* **26**, 127–158.
- Thorner, J. P., Trosper, T. L., and Strouse, C. E. (1978). In "The Photosynthetic Bacteria" (R. K. Clayton and W. R. Sistrom, eds.), pp. 133–160. Plenum, New York.
- Thorne, S. W. (1971). *Biochim. Biophys. Acta* **226**, 113–127.
- Tomaro, M. L., and Frydman, R. B. (1979). *Phytochemistry* **18**, 1433–1436.
- Tomaro, M. L., Frydman, R. B., and Frydman, B. (1977). *Arch. Biochem. Biophys.* **180**, 239–247.
- Troxler, R. F. (1972). *Biochemistry* **11**, 4235–4242.
- Troxler, R. F., and Bogorad, L. (1966). *Plant Physiol.* **41**, 491–499.
- Troxler, R. F., and Brown, A. S. (1975). *Plant Physiol.* **55**, 463–467.
- Troxler, R. F., and Dokos, J. M. (1973). *Plant Physiol.* **51**, 72–75.
- Troxler, R. F., and Offner, G. D. (1979). *Arch. Biochem. Biophys.* **195**, 53–65.
- Troxler, R. F., Kelly, P., and Brown, S. B. (1978). *Biochem. J.* **172**, 569–576.
- Troxler, R. F., Brown, A. S., and Brown, S. B. (1979). *J. Biol. Chem.* **254**, 3411–3418.
- Tuboi, S., Kim, H. F., and Kikuchi, G. (1970). *Arch. Biochem. Biophys.* **138**, 147–153.
- Turner, J. M., and Neuberger, A. (1970). In "Methods in Enzymology" (H. Tabor and C. W. Tabor, eds.), Vol. 17, Part A, pp. 188–192. Academic Press, New York.
- Vicek, L. M., and Gassman, M. L. (1979). *Plant Physiol.* **64**, 393–397.
- Virgin, H. I. (1961). *Physiol. Plant.* **14**, 439–451.
- Wacker, W. E. C., Tait, G. H., and Neuberger, A. (1965). *Biochemistry* **4**, 940–942.
- Wasielowski, M. R., Norris, J. R., Shipman, L. L., Lin, C., and Svec, W. (1981). *Proc. Natl. Acad. Sci. U.S.A.* **78**, 2957–2961.
- Weber, G. (1961). *Nature (London)* **190**, 27–29.
- Weinstein, J. D., and Castelfranco, P. A. (1978). *Arch. Biochem. Biophys.* **186**, 376–382.
- Wider De Xifra, E. A., Sandy, J. D., Davies, R. C., and Neuberger, A. (1976). *Philos. Trans. R. Soc. London, Ser. B* **273**, 79–98.
- Willstätter, R., and Forsen, L. (1913). *Justus Liebigs Ann. Chem.* **396**, 180–190.
- Willstätter, R., and Stoll, A. (1911). *Justus Liebigs Ann. Chem.* **378**, 18–72.
- Willstätter, R., and Stoll, A. (1913). "Untersuchungen über Chlorophyll" Springer-Verlag, Berlin and New York.
- Wolf, H., Brockman, H., Biere, H., and Inhoffen, H. H. (1967). *Justus Liebigs Ann. Chem.* **704**, 208–214.
- Wolff, J. B., and Price, L. (1957). *Arch. Biochem. Biophys.* **72**, 293–301.
- Wolosiuk, R. A., and Buchanan, B. B. (1977). *Nature (London)* **266**, 565–567.

- Wolosiuk, R. A., and Buchanan, B. B. (1978). *Plant Physiol.* **61**, 669-671.
- Woodward, R. B. (1960). *Angew. Chem.* **72**, 651-662.
- Woodward, R. B. (1961). *Pure Appl. Chem.* **2**, 388-404.
- Woodward, R. B., Ayer, W. A., Beaton, J. M., Bickelhaupt, F., Bonnett, R., Buchschacher, P., Closs, G. L., Dutler, H., Hannah, J., Hauck, F. P., Ito, S., Langemann, A., LeGoff, E., Leimgruber, W., Lwowski, W., Sauer, J., Valenta, Z., and Volz, H. (1960). *J. Am. Chem. Soc.* **82**, 3800-3802.
- Wu, S. M., and Rebeiz, C. A. (1982). *Plant Physiol.* **69**, S-394.

Additional references related to Chl and BChl chemical species:

1. Scholz, B., and Ballschmitter, K. (1981). *Angew. Chem. Int. Ed. Engl.* **20**, 956-958.
2. Bazzaz, M. B., and Brereton, R. G. (1982). *FEBS Lett.* **138**, 104-108.
3. Bazzaz, M. B., Bradley, C. V., and Brereton, R. G. (1982). *Tetrahedron Letters* **23**, 1211-1214.
4. Dörnemann, D., and Senger, H. (1982). *Photochem. Photobiol.* **35**, 821-826.

Index

- A**
A, *see* Plastoquinone, pool
A₁, *see* A_{1,1}
A₂, *see* A_{1,2}
A_{1,1} (\equiv Chl *a*; intermediate acceptor), 24,
242–244, 357–359, 437
absorbance change, 358
A_{1,2} (\equiv X; Fe-S species), 244, 245,
359–361, 437
absorbance change, 360
A_{1,3} (\equiv FeS center A \equiv P430), 245–249,
361–363
A_{1,4} (\equiv FeS center B), 245–249
A_{11,1} (\equiv pheophytin; intermediate accep-
tor, I), 252, 253, 373, 374
absorbance change, 373, 374
A_{11,2} (\equiv Q \equiv Q_A), 253, 254
A_{11,3} (\equiv B \equiv Q_B \equiv R), 255
A515, 437, 442
Absorption
anisotropy, 159
polarization, 168, 175
Absorption change
bacterial RC, 352
carotenoid, 436–444
chlorophenol red, 628
electrochromism, 602, 603
neutral red, 568, 628
quinone, 405
Absorption difference spectrum
A_{1,1}⁻/A_{1,1}(chl *a*), 243, 358
A_{1,2}⁻/A_{1,2}(X), 245, 360
A_{11,1}⁻/A_{11,1}, 374
bacteria, 342
bacteriopheophytin, 347
electrochromism, 603
P430, 362
P680, 370, 371
P700+/700, 240, 358, 362, 364
pheophytin, 252, 254, 374
PQ-/PQ, 254, 370, 371
Q (\equiv A_{11,2}), 254
quinones, in bacteria, 222
Rp. sphaeroides, 183, 204, 214
Rp. viridis R.C., 173
Absorption spectrum
bacteriochlorophyll, 165
bacteriochlorophyll-protein, 304, 305,
306
bacteriochlorophyllide *a*, 287
bacteriochlorophyllide *a* cation, 290
bacteriopheophorbide *a*, 286
band center energy, 307
chlorophyll, 165
chlorophyllide *a*, 285
cation, 289
light-harvesting complex, 176
oriented chloroplasts, 179
pheophorbide *a*, 284
PSI-enriched complex, 232
PSII-enriched complexes, 249
shifts, 303–306, 308
Acceptor
BChl, 24
Chl, 24
complex, 25–28
Action spectra, *see* Excitation spectrum of
fluorescence
Activation energy, thermoluminescence,
520
Adenosine diphosphate, *see* ADP
Adenosine monophosphate, *see* AMP
Adenosinetriphosphatase, *see* ATPase
Adenosine triphosphate, *see* ATP
Adenylate kinase, 685
Adenylimidophosphate, 680, 682

- ADP, 544, 580, 648, 658, 668, 676, 677, 679, 683, 687
- ϵ -ADP binding to CF, 682
- ADRY, 425, 488
- Afterglow. *see* Delayed light emission
- Alamethicin, 621
- Algae, slow electrochromic change, 442-445
- α (misses), 480-485
- Aminoacridine, fluorescence quenching, 559, 563, 564, 655, 680
- δ -Aminolevulinic acid (ALA), 736, 757, 758
- biosynthesis, 759-761
- regulation, 760
- chemical structure, 706
- formation, 753-756
- AMP, incorporation into ATP, 685
- Anabaena variabilis*, 432, 676
- Anacystis nidulans*, 446
- Anisotropy
- absorption, 158
- chemical, 158
- electrical, 158
- magnetic, 158
- shape, 157, 158
- Ankistrodesmus*, 475
- ANS, 607
- fluorescence, 559
- Antenna pigments. *see* Light-harvesting complex
- Antibodies
- against coupling factor enzyme, 659, 661
- against plastocyanin, 434
- against reaction centers, 212
- Antimycin, 430, 454, 455, 573, 579, 631
- ATP
- hydrolysis, relation to proton translocation, 650-652
- synthesis
- acid-base transition, 9, 651
- coupling w/proton gradient, 651
- by electric field, 567
- induction of, 560-563
- by ion gradients, 566, 567
- in light flashes, 560, 561
- mechanism, 688, 689
- relation to proton translocation, 650-652
- static head, 563, 580
- in steady state, 563-566
- [γ - 32 P]ATP, 560, 561
- ATP/ $2e^-$ ratio, 46, 47
- in bacteria, 581, 582
- in chloroplasts, 572-575
- ATPase complex, 47, 48, 96, 97, 117, 118
- activity, 670-680
- function, 650-657
- proteolipids, 665
- proton translocation, 547-549
- structure, 657-670
- ATP synthase. *see also* Coupling factor enzyme; ATPase complex
- hydrophobic components, 663-666
- Atrazine resistant weed, 415
- AUT particles, 87, 202
- 2-Azidoanthraquinone, 207
- B**
- B ($\equiv R$; $\equiv Q_B$), 412-416
- effect of bicarbonate, 415, 416
- B800/B850/B890, 50, 91-93, 95, 103, 174-176, 181, 602
- Bacteria
- membrane model, 189
- orientation, 180, 181
- Bacterial photosynthesis, 17-55
- Bacteriochlorophyll (Bchl)
- biosynthesis, 759-767
- coupling with lipid synthesis, 769
- with protein synthesis, 769
- effect of light intensity, 769, 770
- of oxygen, 769, 770
- interaction of Mg and Fe branches, 768, 769
- regulation, 767-770
- scheme, 765
- dimer, 22, 213-216
- electron transfer, 345-348
- orientation, 189
- protein, *Prosthechloris*, 302-306
- structure and distribution, 721
- Bacteriochlorophyll *a*
- cation, 290
- chemical structure, 277, 772
- excited states, 283
- in light-harvesting complex, 307-309
- in R-26 mutant of *Rp. sphaeroides*, 307, 308
- special pair hypothesis, 324-327

- Bacteriochlorophyll *b*, chemical structure, 722
- Bacteriochlorophyll *c*, chemical structure, 722
- Bacteriochlorophyll *d*, chemical structure, 722
- Bacteriochlorophyll *e*, chemical structure, 720
- Bacteriochlorophyllide *a*, chemical structure, 765
- Bacteriopheophytin, 189, 216–220, 345–348
- Bacteriopheophytin *a*
 excited states, 283
 red shift, 405
- Barley mutant, 114, 122, 129, 133
- β (double hits), 480–483
- Bicarbonate
 binding to B-protein, 415, 416
 effect
 on phosphorylation, 679, 680
 in PSII, 472
 reactions, 471
 regulation of electron flow, 415, 416
- Binary oscillations, 28, 29
- Brassica*, 392
- Bromocresol purple, 630
- Buffering capacity, protons, 597
- Bumilleropsis filiformis*, 396, 419, 432
- Butadione, 674
- C**
- C, intermediate, 22, 23
- C400 (plant), 426
- C550, 405, 412
- Calcium, 500
- Calcium ion (Ca^{2+}), 491, 671, 672, 680, 682, 689
- Carbon dioxide
 binding, relation to herbicides, 415, 416
 effect on electron flow, 415, 416
- Carotenoid, 180, 181, 189
 absorption change, 603
 in bacteria, 227, 228
 spectral shift
 characteristic, 439–441
 mechanism, 436–439
- Cation radical states, 288–290
- Cations
 effect
 on ATPase activity, 670, 673
 on chlorophyll orientation, 180
 mechanism of ATP synthesis, 689
 on thylakoid association, 123
- CCCP (carbonylcyanide *m*-chlorophenylhydrazone), 518
- CDNP (4-chloro-3,5-dinitrobenzoic acid), 398
- CF (coupling factor)
 α -subunit, 117, 658–662
 β -subunit, 117–119, 658–662
 γ -subunit, 117–119, 658–663
 δ -subunit, 117–119, 658–662
- CF_0 , 117–119, 124, 546–548, 657–667
- CF_1 , 117–119, 124, 546–548, 657–667
 binding of Mn^{2+} , 672
 fluorescence experiment, 660
 structure, 660
- Charge accumulation, for O_2 evolution, 476, 477, 498–500
- Charge accumulator, 478
- Charge carrier C, 485
- Charge generation, orientation, 550, 551
- Charge separation, 199, 333
- Charge transfer, in bacterial reaction centers, 352–354
- Charlock, 393
- Chemiosmotic hypothesis, 539–550
 basic postulates, 539–540
 criticism, 569, 570
 differences with Williams' hypotheses, 549, 550
 energetics, 541–545
 proton translocation, 545–550
- Chinese cabbage, 234
- Chlamydomonas reinhardtii*, 110, 113, 122, 129, 130, 202, 234, 393, 432, 442, 479
- Chlorella pyrenoidosa*, 179, 373, 377, 412, 422, 442, 443, 471, 474, 481, 487, 515, 516, 558, 576, 731, 732, 740, 741, 742, 766
 magnetic orientation, 179
- Chloride
 NMR, 499
 role in O_2 evolution, 498–500
- Chlorin-6-amide, 708
- Chlorin- c_6 trimethyl ester, 708
- Chlorobiaceae, 76, 77, 88
- Chlorobium limicola*, 20, 22, 31, 32, 70, 74, 83, 88

- Chloroflexus*, 53, 54
 Chlorophenol red, 626, 628
 Chlorophyll (Chl)
 choice of, by nature, 257
 dichroism, 178
 fluorescence, *see* Fluorescence, of chlorophyll
 orientation *in vivo*, 178
 photo-oxidation of, 332–334
 protein complex II, 121
 Chlorophyll *a*
 biosynthesis
 proposed pathway, 725–756
 regulation, 757–758
 cation radical, 288, 289
 chemical forms, 24, 25
 chemical structure, 276, 277, 704, 708, 719
 biosynthetic approach, 707–709
 degradative approach, 707
 synthetic approach, 707
 dimer, 241
 enol, 241, 720
 excited states, 283
 first acceptor in PSI, 334
 fluorescence
 antagonistic effect of light I and II, 406
 effect of triplet state, 406
 factors controlling, 406, 407
 indicator of redox state of Q, 405, 406
 lifetime, 334, 406
 10-hydroxy lactone, 720
 intermediate acceptor, 242
 metabolism, 726–728, 729, 730
 primary donor, 240–242
 chromophores, distribution, 714–716
 detection of new spectral forms, 709–713
 long wavelength form (LW Chl *a*), 716
 short wavelength form, 716
 spectral forms, *see* Spectral forms
 use of fluorescence techniques, 709–710
 Chlorophyll *a/b* protein, circular dichroism, 308, 309
 Chlorophyll *b*
 chemical structure, 704, 708, 719
 exciton interactions, 178, 307, 308
 formation of pool, 756, 757
 orientation, 179
 in solution
 detection
 in minute quantities, 710
 of new spectral forms, 709–713
 Chlorophyllide (Chlide) *a*
 chemical structure, 704, 765
 metabolism, 729, 730
 Chlorophyllide *b*, chemical structure, 704
 Chloroplast
 ATP/2e⁻ ratio, 572–575
 ΔpH, 559
 Δψ, 559
 electrochromic change, slow, 442–445
 electron transport “chain,” 546
 greening, 727, 738, 739
 [¹⁴C]hexylamine distribution, 559
 polypeptide composition, 109–115
 subchloroplast, 559
 Chloroplast membrane
 model, 119
 orientation of antenna, 178–180
Chloropseudomonas ethylica, 302
 Chlorosomes, 51, 82, 83
 Chromatiaceae, 77, 87
Chromatium minutissimum, 93
Chromatium vinosum, 32, 72–75, 77, 91, 92, 97, 102, 204, 219, 223, 227, 397, 398, 405, 408, 437, 441, 594, 620, 621, 658, 662, 670–672, 678, 680, 721, 723, 762
 Chromatophore
 BChl, 84
 composition, 84
 electrogenic events, 618–626
 inside-out, 81
 iodination, 10
 ionic conductivity, 623–625
 light-harvesting complex, 84–89
 lipids, 84
 orientation, 80–82
 preparation, 78
 pronase treatment, 101
 properties, 80–95
 protease treatment, 101, 102
 protolytic reactions, 626–634
 RC, 84, 85
 RC complex, 106
 structure, 80–82

- Circular dichroism
 exciton effects, 296, 298, 307–309
 rotational strength, 307
 spectra, 304
- Configuration interaction, calculations,
 281, 282
- Coproporphyrin (copro), synthesis, 761
- Coproporphyrinogen (Coprogen) III
 biosynthesis, 752
 chemical structure, 706
- Corrinoids, 724
- Coupling factor enzyme, 96, 97, 117, 118
 binding
 to ADP, 682, 683
 of Mn^{2+} , 672
 binding sites, 681–683
 conformational change, 681–688
 function, 650–657
 mechanism of action, 688, 689
 nucleotide bonding, 681–688
 properties, 670–675
 regulation of activity, 657–680
 spatial distribution, 552, 553
 structure, 657–670
 subunit structure, 117–119, 658–660
- GPII complex, 117, 178
- Cresol red, 626
- Criethidia*, 397
- CTAB (cetyltrimethylammoniumbromide),
 86
- Cucumber, 729, 739, 744
- Cyanelle, 51, 52
- Cyanidium caldarium*, 770, 771
- Cyanocyta korschikoffiana*, 52
- Cyanophora paradoxa*, 51
- Cyclic electron transfer chain, in bacteria,
 427–429, 432
- Cyclic electron transport, electrogenic
 steps, 612–614
- Cytochrome (Cyt), 185, 418–431
 in bacteria, 227
 protein chemistry, 418, 419
 spectroscopy, 164
- Cytochrome b_1 , 36
- Cytochrome b_2 , 36
- Cytochrome b_6 (plant), 38, 231, 232, 418,
 419, 421, 426, 437
 E_m , 420
- Cytochrome b_{50} , 551, 619
- Cytochrome b_{550} (plant), 185, 452
- Cytochrome b_{559} (plant), 38, 112,
 418–421, 426, 427, 437
 E_m , 411, 424
 high potential, 425
 low potential, 425
 molecular weight, 392, 418, 419
 properties and function, 424–427
- Cytochrome b_{560} (soluble, plant), 418,
 432
 E_m , 392
 molecular weight, 392, 419
- Cytochrome b_{561} (bacteria), 421, 428–431,
 434, 455
 reductants for, 429, 430
- Cytochrome b_{562} (*E. coli*), 419
- Cytochrome b_{563} (b_6 , plant), 393, 412,
 418, 426
 E_m , 393
 molecular weight, 393
- Cytochrome b_{566} (bacterial), 430–432,
 434
 E_m , 430
- Cytochrome $b-c$ complex, 34–42, 102,
 419–421
- Cytochrome b_6-f complex (plant),
 115–118, 419
- Cytochrome c , 207, 208, 397, 398
 reactions, 31, 32
 reduction by quinones, 400
- Cytochrome c_1 (bacteria), 427, 428, 432,
 434
- Cytochrome c_2 , 102, 227, 397, 398, 423,
 427, 428, 432, 434, 551, 557,
 618, 619
 structure, 390
- Cytochrome c_2 (bacteria), 427, 428, 432,
 434
- Cytochrome c_{550} (bacteria), 397
- Cytochrome c_{552} (bacteria), 398
- Cytochrome c_{553} (bacteria), 90, 91, 185,
 227
- Cytochrome c_{555} (bacteria), 91, 185, 227
- Cytochrome c_{558} (bacteria), 90, 185
- Cytochrome c_m , 619
- Cytochrome c peroxidase, 398
- Cytochrome f (plant), 36, 116, 231, 232,
 368, 421–423, 426, 433, 551
 E_m , 393
 molecular weight, 392, 393, 419
- Cytoplasmic membrane, preparation, 79

D

- DABS (diazoniumbenzenesulfonic acid), 434
- DBMIB (2,5-dibromo-3-methyl-6-isopropylbenzoquinone), 116, 445, 518, 576, 612
- DCCD (dicyclohexylcarbodiimide), 548, 665, 675, 689
- DCCD-binding proteolipid, 117
- DCMU [3-(3,4-dichlorophenyl)-1,1-dimethylurea], 451, 479, 513, 515, 518, 574
 chemical structure, 391
 effect, 415
- Degenerate ground state theory, 300, 301, 325
 relation to bandwidths, 300, 301
- Delayed fluorescence, *see* Delayed light emission
- Delayed light emission, 339, 373, 374, 483, 526, 608, 609, 612, 615
 temperature dependence, 344
 temperature jump, 531
- Dember effect, 599
- 2-Desacetyl-2-hydroxyethyl bacteriochlorophyllide *a*, chemical structure, 765
- 2-Desvinyl-2-hydroxyethyl chlorophyllide *a*, chemical structure, 765
- Detergent treatment, 86, 87
- Diaminopimelic acid, 77
- Dichroism, 160, 178
 Chl *a* *in vivo*, 178
 infrared, 160
 linear
 chloroplasts, 159, 179
 cytochromes, 185
 ratio, 159, 181
- 2,4-Diethyl chlorophyll, 719
- Difference absorption spectrum, *see* Absorption difference spectrum
- Diffusion potential, 604
- Dimyristoylphosphatidylcholine (DMPC), 403, 445
 vesicles, 403
- Dio-9, 548
- γ,δ -Dioxovaleric acid (DOVA), 755
- Dipole
 interaction, 303
 strength, 307
 transition, in special pairs, 325
- Dithiobispropionimide, 208
- Diuron, *see* DCMU
- Divinyl acrylate diester, chemical structure, 704
- Divinyl acrylate monoester, chemical structure, 705
- 2,4-Divinyl chlorophyll, 719
- Divinyl chlorophyll *a*
 chemical structure, 704, 719
 in mutant of maize, 713
- Divinyl chlorophyll *b*, chemical structure, 704
- Divinyl hydroxypropionate, chemical structure, 704
- Divinyl ketopropionate, chemical structure, 704
- Divinyl Mg-protoporphyrin, chemical structure, 705
- Divinyl protochlorophyll, chemical structure, 704
- Divinyl protochlorophyllide
 accumulation in bacterial mutants, 766
 chemical structure, 704
 emission spectrum, 735
 excitation spectrum of fluorescence, 735
- Divinyl protoporphyrin, chemical structure, 706
- Divinyl protoporphyrinogen, chemical structure, 706
- Double hits, oxygen evolution, 480-485
- Doublet, 288, 289
- DT-20, 373
- Durosemiquinone, 401

E

- E432, 436, 446/F664, 670, 672, 674 spectral species *in vitro*, 711-720
- E448 (or E458)-F673 spectral Chl *a* form, formation from protochlorophyllide, 726
- E449 (or E459)-F675 spectral chlorophyllide *a* form, 728, 729
- E_m , (redox potential)
 of BChl, 332
 of $\text{CO}_2/(\text{CH}_2\text{O})$ couple, 34
 of Cyt b_{580} , 392
 of Cyt b_{583} , 393
 of Cyt b_{586} , 430
 of Cyt *c*, 32
 of Cyt *f*, 393
 of ferredoxin, 30, 393

- of ferredoxin NADP-reductase, 301, 393
- of I/I^- , 26, 218, 344
- of $NAD^+/NADH$, 34
- of $NADP^+/NADPH$, 30
- of P^+/P , 341
- of $P700/P700^+$, 357, 393
- of pheophytin, 242, 373
- of plastocyanin, 393
- of plastoquinone, 399, 413
- of Q_s , 414
- of Q_A/Q_A^- , 341, 408, 410, 411
- of Q/Q^- , 34, 40
- of quinone, 26
- of Rieske Fe-S center, 420, 421
- of ubiquinone, 399, 408
- Ectothiorhodospira mobilis*, 77
- EDTA (Ethylenediaminetetraacetic acid), 80, 491, 493, 494, 499, 569, 686
- EF particles, 128-131
 - EF_s, 124, 126
 - EF_u, 124-126
- Eigenvector, 300
- Electric capacitance, 596, 597
- Electric field
 - delocalization of coupling, 567-571
 - formation, 555-558, 567
 - localized (delocalized) 625, 626
- Electric potential difference
 - in bulk phases, 616
 - in continuous light
 - chromatophores, 621-623
 - thylakoids, 615-617
 - magnitude
 - chromatophores, 621-623
 - thylakoids, 614-617
 - in single flashes
 - chromatophores, 621
 - thylakoids, 614, 615
 - surface potential, 616
 - transmembrane, 615, 616
- Electrochromic shift at 770 nm, 224
- Electrochromism
 - bacteria, 439-442, 559
 - effect of applied voltage, 604, 605
 - kinetics, 601, 602
 - plants, 442-445, 559
 - principle, 600, 601
- Electrogenic events
 - bacteria, 441, 442, 618-626
 - chromatophores, 618-621
 - kinetics, thylakoids, 610
 - plants, 442-445, 609-631
 - topology, thylakoids, 610
- Electromagnetic wave, interaction in oriented sample, 158-164
- Electron acceptor
 - photosystem I, 238, 239, 357-365
 - photosystem II, 238, 239, 373-377, 409-417
 - purple bacteria, 238, 239, 340-354, 407-409
 - secondary
 - in bacteria, 223-225
 - in photosystem II, 412-417
- Electron density maps
 - bacteriochlorophyllide *a*, 280
 - chlorophyllide *a*, 279
- Electron donor
 - to P700, 431-435
 - to P870, 431-435
 - of photosystem I, 238, 356, 357, 368, 369
 - of photosystem II, 238, 377-379
 - of purple bacteria, 238
- Electron flow, 20, 70. *See also* Electron transfer; Electron transport
- Electron microscopy, 125, 126, 134, 212
- Electron transfer, *see also* Electron transport
 - back reactions, 337-339
 - in bacteria, 20, 203, 546
 - cyclic chain, 427-429, 546
 - early steps, 340
 - from Q_A^- to Q_B in bacteria, 408, 409
 - times, 340, 346, 427
 - "chain," 33, 34
 - components, distribution, 127, 128
 - gross topology, 592
 - kinetics, cytochromes, 421-424
 - linear chain, 422, 423, 546
 - mechanisms, 391-398
 - to P700, 431-435
 - to P870, 431-435
 - in plants, 201, 230, 355, 546
 - proteins, properties, 392, 393
 - from Q_A^- to PQ, 409-417
 - on water side, 453
 - from plastocyanin to P700⁺, 368, 369
 - properties, methods, 405-407
 - speed, 334-339

- Electron transfer (*continued*)
 theory, 391–398
 vectorial, 435–449
- Electron transport, *see also* Electron transfer
 basal, 578
 chromatophores, 637
 cyclic, 612–614
 electrogenetic steps
 chromatophores, 621–626
 thylakoids, 609–620
 linear, 609–612
 thylakoids, 635
 vectorial, 435–449
- Electron transport chain components
 bacteria, 432, 546
 chloroplasts, 426, 437, 546
- Electron tunneling, 260, 336, 394–397
- Electrophoresis patterns, PSI-enriched preparations, 233
- Emerson enhancement, *see* Enhancement effect
- Emission spectrum, chlorophyll *a*, in solution, 712
- ENDOR, 22, 214–216, 324
 P700⁺, 241
- Energetics of H₂O decomposition, 472, 473
- Energy, *see also* Exciton
 coupling, 73
 percolation, 318
 transduction, 44, 48
 trapping, 321
- Energy conversion, 571–583
 stoichiometries, 571–583
- Energy distribution, regulation, 137–139
- Energy gaps, between intermediates, in bacteria, 340, 344–346
- Energy levels
 bacterial intermediate, 346
 special pair, 326
 triplet radical pairs, 351
- Energy transfer, 5, 6, 131
 model, 314
 regulation, 137–139
 time, 315
 uphill, 315
- Enhancement effect, 6
 in isolated chloroplasts, 8
- EPR (electron paramagnetic resonance), *see* ESR
- Escherichia coli*, 723, 762
- ESR (electron spin resonance), 186
 of A₁⁻, 366, 367
 of A₁⁺ (pheophytin), 253
 of FeS-center A (A₁^{-1,3}), 247
 of FeS centers in PSI, 248, 361
 of I⁻, 219, 243, 244
 of manganese, 494, 495
 of P680⁺, 372
 of P700⁺, 241
 of Ph⁻, 374
 of primary acceptor, bacterial, 221
 of quinone, bacteria, 229
 of reaction centers, bacterial, 208, 214–216
 of semiquinone, 26, 27
 of TSFIIa, 375
 II Very fast (V_f), 452
 of X⁻, 186
 of X⁻(A₁⁻²), 246, 366, 367
 of Z⁺(D₁⁻²), 378, 452
- Etheno-ADP, binding to CF₁, 682
- 1,*n*⁶-Etheno-ADP, 580
- N*-Ethylmaleimide, 683, 684
- 2-Ethyl-4-monohydroxyethyl chlorophyll, 719
- 2-Ethyl-4-vinyl chlorophyll, 719
- Euglena gracilis*, 32, 128, 129, 131, 397, 398, 432, 713, 743, 744
- Evolution, 260–263
- EXAFS, 226
- Excitation energy, *see* Energy; Exciton
- Excitation energy transfer, 131
 regulation by phosphorylation, 139
- Excitation spectrum of fluorescence
 chlorophyll *a*
 extracted
 from Chl-protein complexes, 715
 from etiolated cucumber cotyledons, 727
 in solution, 712
 chlorophyll *b*, in solution, 713
 protochlorophyllide, in solution, 733, 735
- Excited state
 bacteriochlorophyll, 281
 bacteriopheophytin, 281
 cation radicals, 288–290
 chlorophyll, 281
 levels, in bacterial RC, 326
 lifetime, 317, 319, 334
 pheophytin, 281

- singlets, 282–287
 - triplets, 287, 288
 - Exciton, 294, 295
 - annihilation, 323
 - concept, 294, 295
 - coupled aggregate, 299, 300
 - coupling energy, *J*, 309–311
 - degenerate-ground state theory, 300, 301
 - dimer, 297–299
 - distribution, 137–139
 - effects in spectra, 295–303
 - hopping theory, 311–322
 - kinetics, 322
 - levels, 304, 305
 - lifetime, 312, 315, 317, 320
 - master rate equation, 312
 - migration, 309–322
 - migration time, 309
 - narrowing, 301
 - nature of motion, 310, 311
 - percolation, 318
 - singlet 283
 - splitting, 326
 - standard theory, 297–300
 - states
 - of antenna Chl, 302–309
 - of BChl-protein, 303
 - theory, experimental test, 301, 302
 - transfer model, 313–320
 - transfer rate, 311–322
 - transition, 307
 - trapping, 321
 - Exoplasmic fracture face, 124–126
 - Extinction coefficient, BChl *a*, 333
- F**
- F_{680} , 546–548, 663–666
 - F_{1} , 546–548, 657–667
 - Farnesyl, chemical structure, 722
 - Ferredoxin
 - chemical structure, 390
 - E_m , 393
 - molecular weight, 393
 - Fluorescence, of chlorophyll, 10, *see also*
 - Emission spectrum, Excitation spectrum of fluorescence
 - antenna, 320
 - area over induction curve, 413
 - change, relation to two photosystems, 7
 - delayed, 10
 - depolarization, 6
 - excitation polarization, 176
 - as indicator of redox state of primary acceptor, 405, 406
 - lifetime, 319, 334
 - nonexponential decay, 319, 320, 323
 - picosecond, 320
 - polarization, 179, 187
 - polarization spectra
 - BChl *a*, 165
 - Chl *a*, 165
 - CPH, 177, 178
 - variable, 373
 - Fluorescence bands
 - in chloroplasts, 130
 - in solutions, 710, 712, 713, 715, 727, 729, 733
 - Fluorescence spectrum
 - of chlorophyll *a* in solution, 712
 - of chlorophyll *b* in solution, 713
 - of protochlorophyllide in solution, 733
 - Förster resonance theory, 310, 311
 - Franck-Condon principle, in electron transfer, 336
 - Freeze-fracture particles, 128–132
 - exoplasmic, 128–131
 - protoplasmic, 131, 132
- G**
- ΔG_{ATP} , 542–544, 561–563, 565, 580, 653, 655
 - Gleocapsa, 51
 - Glow curves, 509–531
 - of *Chlorella*, 516
 - peaks, 511
 - of spinach leaves, 510
 - of spruce, 523
 - of wheat, 522
 - Glutamic acid, 754, 755
 - Gouy-Chapman theory, 617
 - Gramicidin, 554, 624–625
 - Grana stacks, 123, 125
 - factors regulating, 123, 124, 133–135
 - function, 135–140
 - Green bacteria, 228, 229
 - intermediate acceptor, 229
 - primary acceptor, 229
 - primary donor, 228
 - reaction center preparation, 228
 - subunit of RCs, 228
 - Greening of chloroplasts, 727, 738, 729
 - Ground state, degenerate, theory, 300, 301

- GTP, 682, 685
 Guanosine triphosphate, *see* GTP
g value (ESR)
 $A_{1,2}(X)$, 27
 $A_{1,3}$, 27
 Fe-S center, 27
 of I^- , 218, 243
 of Ph^- , 374
 of Rieske Fe-S center, 421
 of semiquinone, 26, 27
- H**
 H, intermediate, 22, 23
 H^+/ATP ratio, 46, 564, 652-657
 in bacteria, 579-581
 in chloroplasts, 577, 578
 H^+/e_2 ratio, 46,
 in bacteria, 578, 579, 656
 in chloroplasts, 575, 576, 656
 H^+/PP_i ratio, in bacteria, 579-581
Halobacterium halobium, 67, 187, 669
 Hamiltonian operator, 282
 Harderoporphyrogen (haderogen), 752
 Heme of bacteria, 721
 chemical structure, 723
 synthesis, 759-764
 Heme *a(b)*
 chemical structure, 723
 formation, 764
 synthesis, 759-764
 Heme oxygenase, 771
 HEPES (*N*-2-hydroxylpiperazine-*N'*-2-ethanesulfonic acid), 569
 Herbicide binding protein, 392, 415-417
 effect of bicarbonate, 415, 416
 molecular weight, 392
 Hexamethylenediamine, 234, 235
 Hill-Bendall scheme, *see* Z-scheme
 HOMO (highest normally filled orbital), 332, 333, 337, 354
 HOQNO (2-*n*-4-Hydroxyquinoline *N*-oxide), 448, 763
Hosta sieboldii, 743
 HP700, 231
 Hydrogen ion, *see* H^+ , Protons
 Hydrogenase, 74, 75
 Hydroquinone, *see* Quinone
 10-Hydroxychlorophyll, chemical structure, 708
 Hydroxylamine (NH_2OH), 490-493, 518
- N*-2-Hydroxymethylpiperazine-*N'*-ethanesulfonic acid, 672
- I**
 I, intermediate, 22, 23
 Imidazole, 562, 563
 Immunological studies
 on CF, 661
 crossed electrophoresis, 99, 100
 plastocyanin, 434
 reaction centers, 212
 Intermediate acceptor (I)
 absorption change, 217, 218
 in bacteria, 216, 220, 341-345
 in photosystem I, 358
 Intersystem crossing, to triplets, 336
o-Iodosobenzoate, 662
 Ion gradients, synthesis of ATP, 566, 567
 Ionic conductance, 623-625
 Ionophores, *see* specific substance
 Ion redistribution, 607, 608
 Iron in RCs, 26, 27
 Iron porphyrins, formation, 763, 764
 Iron-quinone complex in bacteria, 408
 Iron-sulfur centers, 231, 361-368, 420, 437
 proteins, molecular weight, 393
 Rieske, 420
 Iron-sulfur proteins, 74, 393
 in bacteria, 186
 in photosystem I, 234, 361-365
- J**
J
 magnetic coupling constant, 396
 resonance interaction energy, 299, 309
 "Jump method," for delayed light emission, 531
- K**
 Kasha-Tinoco theory, 297
 K^+ flux, 561, 620, 622
 Kok's O_2 model, 477
 Koopman's theorem, 278
- L**
 Lamellae, *see* Grana stacks, Stroma
 Laser, *see* Picosecond measurements
 Lattice model
 for exciton hopping, 313-319

- geometry, 316
 - parameters, 316
 - Lauryl dimethylamine oxide (LDAO), 73, 74, 86, 87, 89, 202
 - LHC II (L), *see* Light-harvesting complex
 - Lettuce, 655
 - Light absorption, *see* Absorption change, Absorption spectrum
 - Light emission, *see* Fluorescence, of chlorophyll; Delayed light emission
 - Light-harvesting Chl-protein complex, 121, 716
 - Light-harvesting complex
 - bacterial, 69, 70, 82, 91, 92, 174, 177
 - adaptation to light, 69
 - excitation, 307, 308
 - organization, 92–96
 - polarized absorption, 175
 - preparation, 92
 - structure, 92–96
 - plants
 - amino acid composition, 136
 - fluorescence polarization, 177, 178
 - isolation, 133
 - phosphorylation, 138, 139
 - of PSI (I), 111–115, 122, 123
 - of PSII (II), 109–112, 121, 123
 - Light reaction, *see* Primary events; Primary photochemistry
 - Linear dichroism, 159, 168, 177
 - exciton effect, 299, 306, 307
 - Luminescence, *see* Delayed light emission
 - LUMO (unoccupied molecular orbital), 332, 337, 354
 - LWMP (longer wavelength absorbing metalloporphyrins), 741, 742
- M**
- M, intermediate, 478
 - Magic angle, 162, 175
 - Magnesium (Mg^{2+}), 556, 650, 671–673, 689
 - Magnetic coupling constant, 396
 - Magnetic field effects, 180, 349, 350
 - Magnetic orientation, 181, 182, 185
 - Magnetic susceptibility, 225
 - Magnetophotoselection, 163, 185, 188
 - Maize, mutant ON 8147, 713, 719
 - Manganese
 - ESR, 494, 495
 - heterogeneity, 490, 491
 - in O_2 evolution, 490–497
 - NMR, 491–494
 - pools in thylakoids, 490–494
 - redox changes, 491–497
 - relation to thermoluminescence, 524
 - x-ray absorption edge, 496
 - Marcus theory, 394–396
 - Mass spectra, field desorption, 720
 - Mastigocladus laminosus*, 658, 671
 - Membrane, *see also* Chloroplast membrane, Thylakoid membrane
 - bacterial model, 189, 258, 434, 546
 - biosynthesis, 105–108
 - buffering capacity, 597
 - capacitance, 556, 614, 623
 - components
 - chromatophores, 637
 - thylakoids, 635
 - electrical model, 595, 596
 - electric capacitance, 596, 597
 - fractionation, 202
 - immunological characteristics, 99, 100
 - ion conductivity, 569
 - localization of components, 100–104
 - local order, 187, 199
 - mobility of quinone, 402–404
 - model, 104
 - chromatophores, 637
 - thylakoids, 635
 - organization, 97–104
 - orientation, 157–161
 - antenna, 178–181
 - potential, 45
 - properties, 594–598
 - reconstitution, 104, 105
 - resistance, 597, 598
 - size and shape, 594, 595
 - structural complexes, adaptation, 68
 - surface potential, 417, 418, 596
 - thylakoid model, 259, 437, 546
 - topological organization, 98, 99
 - vesicles, inhomogeneity, 598
 - viscosity changes, 107
 - Membrane potential, 540, 556–561, 564, 622
 - measurements, 598–609, 605
 - by delayed fluorescence, 608, 609

- Membrane potential (*continued*)
 by electrochromism, 600–606
 by electrodes, 599, 600
 by extrinsic voltage probes, 606, 607
 by ion redistribution, 607, 608
- Membrane surface potential, 417, 418
- Menaadiol, 400
- Menaquinol, 400
- Menaquinone, 26, 90, 91, 223, 407
 chemical structure, 390
 MQ-7, 398
- β -Mercaptoethanol, 235
- Mesodinium*, 52
- Metalloporphyrins, in greening colytedons, 741
- Methylamine distribution, 559, 655
- Mg-2,4-divinyl pheoporphyrin a_5 mono-methyl ester, chemical structure, 765
- Mg-protoporphyrin ester, 742–745
- Mg-protoporphyrin monomethyl ester, chemical structure, 765
- Mg-protoporphyrin pool, 746–748
- Micrococcus denitrificans*, 397
- Misses (α), 480–485
- Mitchell theory, 9, 402, 435, 436, 539–550
 ATP synthesis, chemistry, 688
 basic postulates, 539–541
 comparison with Williams' theory, 550
 energetics, 541–545
 proton translocation, 545–549
- Mobility, of carriers, 44
- Molar ellipticity, 304, 305
- Molar extinction, of BChl *a*-protein, 304, 305
- Molecular orbitals, canonical, 278–281
 energies, 281
 occupied (HOMO), 332, 333
 unoccupied (LUMO), 332, 333
- Molecular weight
 CF₁, 658, 665
 Cyt *b*₅₅₉, 392
 Cyt *b*₅₆₀ (soluble), 392
 Cyt *b*₅₆₃, 393
 Cyt *f*, 392, 393
 F_o proteolipid, 666
 F₁, 658
 ferredoxin, 393
 ferredoxin-NADP⁺ reductase, 393
 herbicide-binding protein, 392
 P680 complex, 392
 P700 complex, 393
 plastocyanin, 393
 quinone-binding protein, 415, 416
 subunits of CF₁, F₁, 658, 659
- 2-Monohydroxyethyl-4-ethyl-chlorophyll, 719
- Monovinyl acrylate diester, chemical structure, 704
- Monovinyl chlorophyll *a(b)*, chemical structure, 704, 719
- Monovinyl hydroxypropionate, chemical structure, 704
- Monovinyl ketopropionate, chemical structure, 704
- Monovinyl Mg-protoporphyrin, chemical structure, 705
- Monovinyl protochlorophyllide
 chemical structure, 704
 emission spectrum, 735
 excitation spectrum of fluorescence, 735
- Monovinyl protoporphyrinogen, chemical structure, 706
- MOPS (3-(*N*-morpholino)propanesulfonic acid), 569
- Mössbauer measurements, 225, 227, 408
- MPE, *see* Mg-protoporphyrin ester
- Mutants, use, 129
- Myxothiazol, 427, 428, 434
- N**
- NAD⁺ (nicotinamide adenine dinucleotide), 20, 203, 261
- NADP⁺ (nicotinamide adenine dinucleotide phosphate), 20, 36, 230, 261
- NBD-Cl, 660, 661
- NDCCD, 665
- NEM (*N*-ethylmaleimide), 683, 684
- Nerium oleander*, 130
- Nernst–Planck relationship, 607
- Neutral red, use in pH measurement, 568, 569, 627, 628
- Non-heme iron
 in bacteria, 225–227, 408
 in Cyt *b-c* complex, 419, 420
- Nuclear magnetic resonance (NMR)
 of chloride, 499

- of fluoride, 499, 500
- of protons
 - in quinones, 403
 - in thylakoids, 491-494
- Nucleotide binding, to CF₁, 681-688
- O**
- Octylglucoside, 663
- Orientation
 - degree, 161
 - fluctuations, 161
 - of membranes, 157, 158
 - perfect, 158, 159
 - of pigments, 166-178
 - techniques, 157, 158
- Orientation factor, 311
- Oscillations
 - binary, 28, 29
 - period of, 4, 477
- Overlap integral, 311
- Oxocarbocyanine, 607, 621
- Oxidation-reduction, 19, 21
 - convention, 26
- Oxygen, source, 470, 471
- Oxygen clock, 477, 495
- Oxygen-18 labeling, 471, 472
- Oxygen evolution, 8, 9, 453-498
 - chemistry, 489-500
 - damping mechanisms, 480-485
 - double hits, 480-483
 - independent centers, 479
 - kinetic model, 477-489, 530
 - kinetics, 473-489
 - light activation, 474, 475
 - in light flashes, 477
 - protein components, 497, 498
 - proton release, 632-634
 - relation to thermoluminescence, 522-531
 - role of chloride, 498-500
 - of manganese, 490-497
 - stability of intermediates, 486-489
- P**
- P430, 247, 248, 361-363
- P680, 23, 182, 369-372, 426
 - back reaction, 375-377
 - complex, molecular weight, 392
 - electron donation, 377-379
- P700, 6, 23, 24, 356, 357, 426, 437
 - absorption in blue, 248
 - amino acid composition, 237
 - back reaction, 365, 366
 - cross linking, 235
 - E_m*, 357
 - electron donation, 368, 369, 431-435
 - enriched complexes, 230-249
 - extinction coefficient, 357
 - orientation, 181
- P840, 27, 228, 229
- P870; *also see* Reaction center, bacteria
 - E_m*, 432
 - electron donation, 431-435
- P960, 90
- P/e₂* ratio, 656, 657
- P. aeruginosa*, 396
- Paracoccus denitrificans*, 264
- P_i-ATP, exchange, 652, 663, 668
- PCMB (*p*-chloromercuribenzenesulfonic acid), 573
- Pelomyxa palustris*, 52
- Peperomia metallica*, 599, 614
- PF particles, 131, 132
- PF_s, 124-126
- PFu, 124-126
- pH
 - difference, 558-560
 - correlation with ATP, 563
 - indicating dyes, 626-628
 - o*-Phenanthroline, 26, 227, 434, 762
- Phenol red, 626
- o*-Phenylenebismaleimide, 675
- Phenylglyoxal, 674
- Phenylmethylsulfonyl fluoride, 80
- Pheophytin
 - absorption spectra, 252, 374
 - as acceptor of PSII, 252, 373, 374
 - ESR spectra, 253
 - trapping of pheophytin in PSII, 374
- Pheophytin *a*
 - absorption spectra, 284
 - excited states, 283, 284
- Phlorizin, 573
- Phormidium luridum*, 500
- Phosphate potential, 582
- Phosphatidylcholine, 84
- Phosphatidylethanolamine, 84
- Phosphatidylglycerol, 84

- Phospholipids, 84, 90
 distribution, 97, 98
- Phosphorylating unit, 553, 554
- Phosphorylation, 9
 discovery, 571
 effect of buffers, 562
 electrodic model, 571
 general sequence, 591
 induction, 555-563
 of light-harvesting complex, 138, 139
 mechanism, 538-583, 688, 689
 reconstitution, 666-670
 steady state, 563-566
- Photochemical reactions, of reaction centers, 198-202, 332-334
- Photodichroism, 163
- Photolyte, 471
- Photophosphorylation, *see*
 Phosphorylation
- Photoreceptor complex, 204
- Photoselection, 162-164, 169, 172, 178,
 181, 184, 185, 187
 oriented objects, 164
 random suspension, 162
- Photosynthesis, 1-4
 evolution, 51-55
 literature, 11, 12
 overall equation, 470
- Photosynthetic systems, 70, 71
- Photosynthetic unit, 5-8, 120, 310, 474
- Photosystem, dissociation, 121
- Photosystem I (PSI), 114, 115
 amino acid composition, 236, 237
 components, 426
 intermediate acceptors, 242-244
 location in membrane, 259
 polypeptides, 112-115
 primary acceptor, 244, 358, 359-365
 primary donor, 240-242, 356, 357
 protein
 properties, 392, 393
 structure, 233-237
 secondary acceptors, 245-249
 subunit structure, 233-236
- Photosystem II (PSII)
 back reaction, 375-377
 components, 426
 intermediate acceptor, 252, 253, 373,
 374
 location in membranes, 259
 membrane surface potential, 417, 418
 polypeptides, 109-112
 primary acceptor, 253, 255
 primary donor, 250-252, 369-372
 protein
 composition, 250
 properties, 392, 393
 quinones, 409-417
 secondary acceptor, 255
 turnover, 479, 480
- Phycobilins
 chemical structure, 724
 synthesis, 770, 771
- Phycobilisomes, 51, 70
- Phycocyanobilin, chemical structure, 724
- Phycocerythrobilin, chemical structure, 724
- Phytyl, chemical structure, 722
- Picosecond measurements
 in bacteria, 342, 343, 347, 348, 352, 353
 exciton effects, 323
 on P700, 248, 334, 363, 364
 in photosystem I, 363-365
- Pigment
 antenna, orientation, 179-181
 arrangement, 319
- Pigment-protein, distribution, 127, 128
- Pisum sativum*, 110
- pK, 40
- Plastocyanin, 33, 43, 44
 crystal structure, 433
 in electron flow, 432-435, 437
 E_m , 392, 393
 as mobile carrier, 432-435
 molecular weight, 393
 structure, 390
- Plastoquinone, 253-255
 chemical structure, 390
 E_m , 399
 in electron flow, 413
 mobility, 404
 pool, 443
 in Q_B , 415
- Plastosemiquinone, 26, 401, 402
- PMS (phenazinemethosulfate), 667
- Polarization, 168, 169, 175
 chlorophyll fluorescence, 187
 of fluorescence, 163
 value, 163
- Polypeptides
 photosystem I, 112-115

- 70 kD, 253
- photosystem II, 109–112
 - 32 kD, 497
 - 34 kD, 498
 - 43 kD, 250, 251
 - 65 kD, 497
- thylakoids, 109–115
- Porphobilinogen (PBG)
 - biosynthesis, 753
 - chemical structure, 706
- Potential, operating, 39
- Potential difference, bulk, 615, 616
- Prenyllipids, formation, 771, 772
- Primary acceptor
 - in bacteria, 220–223, 340, 341, 407–409
 - in plants, 357–364, 371, 409–412
 - quinones, 404–418
- Primary donor
 - in bacteria, 213–216
 - dimer, criticism, 326
 - monomer, 326, 327
 - in plants, 356, 357, 369–372
- Primary events, *see* Primary photochemistry
- Primary photochemical reaction, *see* Primary photochemistry
- Primary photochemistry, 21–25, 332–339
 - back reactions
 - in bacteria, 337, 338
 - in plants, 365, 366, 375–377
 - in bacteria, 339–354
 - in plants, 354–366
- Prochloron didemni*, 52, 54, 133
- Prosthecochloris aestuarii*, 28, 32, 88, 95, 157, 177, 302
 - bacteriochlorophyll-protein, 302–306, 307, 322
- Protease inhibitor, 80
- Protein
 - compositional divergence, 262–264
 - distribution, 97, 98
 - homology, 262–264
 - in oxygen evolution, 497, 498
 - quinone binding, 415–417
- Protein-lipid ratio, 50, 77, 84, 97, 106
- Proteolipid subunit of F_o , 664–666
- Protochlorophyll (PChl)
 - chemical structure, 704
 - fluorescent species, 739
 - holochrome (PChl-H) pool, 737–740
 - pools, formation, 730–740
- Protoheme
 - chemical structure, 723
 - synthesis, 763, 764
- Protolytic reaction
 - kinetics
 - chromatophores, 619
 - thylakoids, 610
 - topology
 - chromatophores, 619, 637
 - thylakoids, 610, 635
- Proton/ATP ratio, *see* H^+ /ATP ratio
- Proton binding, 409, 579
- Proton efflux, 574
- Proton/electron ratio, *see* H^+/e_2 ratio
- Proton flux, general scheme, 592
- Proton gradient, 540, 555–571, 655n. *See also* pH difference
 - electrochemical, kinetics, 555–563
 - rate of formation, 555–560
 - transmembrane, 555–571
- Proton liberation, 9
- Proton motive force, 44–46, 540, 541, 544, 555, 556, 564
 - correlation with ATP, 563
- Proton relaxation rates, 491–494
- Proton release, in plants, 450–453, 489, 490, 576, 632–634
 - kinetics, 568, 633
 - relation to S-state, 451–453, 489, 490, 632–634
- Proton translocation
 - through ATPase, 547–549
 - redox pumps, 545–547
 - vectorial, 445, 446, 546
- Proton translocator, 604
- Proton uptake
 - in chromatophores, 454–460
 - in plants, 453, 454
- Protoplasmic fracture face, 81, 124–126
- particles, 131, 132
- Protoporphyrin (Proto)
 - pool, 748–751
 - synthesis in bacteria, 761–763
- Protoporphyrinogen IX, biosynthesis, 751, 752, 762
- Pyridoxal phosphate, 661
- P^f state, 217
- P^R state, 348–350

- Q**
- Q, quencher of chlorophyll fluorescence
in vivo, see $A_{II,2}$, Q_I , Q_A
- Q_A
 bacteria ($\equiv Q_I$), 340, 341, 407–409, 434
 E_m , 432
 plants ($\equiv A_{II,2} \equiv Q \equiv Q_I \equiv X-320$),
 409–417, 437
 E_m , 410
 heterogeneity, 254, 411, 412
in photosystem II, 253–255, 409–417
 titration, 414
- Q_B
 in bacteria ($\equiv Q_{II}$), 407–409, 434
 E_m , 432
 as 2-electron gate, 408, 409, 412–414
 in plants ($\equiv B \equiv R$), 412–416, 437, 455
- Q_B -protein ($\equiv B$ protein), 416
- Q_b (bulk) ubiquinone, 432
- Q_c , 434, 437, 448, 449
- Q_H (plants), 411, 412, 414
- Q_L (plants), 411, 412, 414
- Q_z , 417, 429, 432, 434, 449, 455
- Q_1 , 482
- Q_2 , 482
- Q_I , see Q_A
- Q_{II} , see Q_B
- Q_{III} , see U
- Q-cycle, 35–42, 428–431
 in bacteria, 434
 modified, 447–449
- Q-loop, 435, also see Q-cycle
- Quantasome, 120
- Quantum yield, photochemistry, 334
- Quinol, 399
- Quinone
 acceptor complex in bacteria, 408
 in bacteria, 220–225, 427
 diffusion coefficient, 404
 as electron acceptor, 25, 26, 28–30,
 404–418
 mobility, 402–404
 in photosystem II, 409–417
 properties, 398–404
 protolytic reactions, 628–632
 chromatophores, 631, 632
 thylakoids, 629, 630
 in proton translocation, 445, 446
 protonation, 399
 quinone-iron complex, 221
 redox reactions, 399
 reduction of Cyt c , 400
 species, 398, 399
- Quinone-acceptor complex
 bicarbonate effect, 416
 of photosystem II, 416
 two-electron gate, 416
- Quinone-binding protein, 415–417
- R**
- R ($\equiv B$, $\equiv Q_B$), 412–415
- Radish, 393
- Randall-Wilkins theory, 519, 520
- Random walk of excitons, 310, 321
 first passage time, 315
- Reaction center, 6, 21–28, 181–185, 197,
 198
 assays, 198–202
 bacteria, 182–185
 amino acid composition, 208–210
 amino acid sequence, 210
 comparison with plants, 256–262
 compositional divergence, 263
 cytochromes, 227, 228
 green, 228, 229
 intermediate acceptor, 213–220
 location, 210, 211
in membrane, 258
 molecular weight, 210, 211
 monomer, 325–327
 non-heme iron, 225–227
 picosecond absorbance, 342, 343, 347,
 348
 preparations, 204, 205
 primary acceptor, 220–223
 primary donor, 213–216
 primary reactants, 213–229
 protein structure, 205–213
 reconstitution, 212, 213
 secondary acceptor, 223–225
 composition, 88–92, 200, 201
 difference absorption spectra, 171
 exciton effects, 323–327
 location, 210, 211
 model, 103
 molecular weight, 210, 211
 pigment orientation, 167–174
 plants
 amino acid composition, 236, 237
 comparison with bacteria, 256–262

- green, 174, 182–185
 location in membrane, 259
 in Photosystem I, 230–249
 in Photosystem II, 249–255
 preparation, 230–232, 249, 250
 primary reactants, 237–245, 250–255
 protein structure, 233–237, 250
 secondary acceptor, 245–249, 255
 subunit structure, 233–236
 preparation, 85–88, 200, 201, 204, 205
 protein structure, 205–213
 of PSI, 111
 of PSII, 111
 subunits, 88, 205–208
 transition moments, 170
 triplet, 23
- Redox potentials, *see also* E_m
 of electron carrier of chloroplasts, 426
- Resistance, electric, 597, 598
- Resonance interaction energy, 297, 298
- Resonance Raman spectroscopy, 216
 of bacterial reaction centers, 219
- Resonance theory, of energy transfer,
 310, 311. *See also* Energy; Exciton
- Rhodopseudomonas capsulata*, 32, 38, 43, 73,
 74, 81, 89, 100, 102, 105, 204,
 397, 405, 424, 437, 440, 441,
 454, 548, 552, 559–561, 565,
 580, 581, 594, 618, 620, 654,
 655, 658, 662, 676, 677–679,
 767, 770
- Rhodopseudomonas gelatinosa*, 90, 204, 207,
 621
- Rhodopseudomonas minutissimum*, 204
- Rhodopseudomonas palustris*, 32, 92, 93, 184,
 187
- Rhodopseudomonas sphaeroides*, 22, 25, 32,
 33, 38, 40, 41, 43, 48, 72–75,
 79–81, 84, 89–92, 94, 97–100,
 102, 105, 107, 167, 171, 175,
 177, 204–212, 214, 216–219,
 222–227, 258, 259, 263, 307,
 313, 321, 324, 334, 342, 347,
 352, 353, 397, 401, 404, 405,
 407, 408, 420, 430, 432, 437,
 439–441, 448, 454, 547, 550,
 551, 559, 579, 580, 594, 618,
 620, 621, 676, 721, 732, 759,
 760, 762–764, 766–769
 chromatophore composition, 82–84
 R-26, 85, 88, 92, 93
 strain 2.4.1, 84, 86, 89, 93, 107, 175,
 176
 strain Y, 86, 89
- Rhodopseudomonas viridis*, 22, 23, 32, 49,
 72, 87, 90, 91, 103, 172, 180,
 183–186, 204, 205, 207, 213,
 215, 218, 223, 315, 322, 343,
 401, 405, 441, 721
- Rhodospirillaceae, 77–79, 85–90
- Rhodospirillum rubrum*, 32, 35, 73–75, 78,
 79, 81, 89–93, 95, 103, 173, 185,
 186, 204, 205, 207–211, 223,
 263, 343, 347, 348, 397, 407,
 408, 441, 559, 566, 578, 594,
 649, 650, 654, 655, 658, 660,
 664, 668, 669, 672, 676–679, 767
 G9-strain, 85, 95
- Rhodospirillum tenue*, 79
- Ribulose-1,5-bisphosphate carboxylase
 (RuBPC'ase), 124
- Rieske Fe-S center, 36, 116, 420–423,
 426, 427, 437
 E_m , 420, 422, 432
- S**
- S, order parameter, 159–161
- Scenedesmus*, 474, 524
- SDS (sodium dodecyl sulfate), 86, 111,
 113, 206, 235, 251, 664
- SDS-polyacrylamide gels, of photosystem
 II, 251
- Second Emerson effect, *see* Enhancement
 effect
- Self-consistent field calculations, 277–
 278
- Semiquinone, 400
 reducing strength, 400, 401
 stability, 400, 401
- Sepharose, 68, 87
- Signal II *vf*, 378
- Single floating spherical Gaussian orbitals,
 277, 278
- Singlet states, 23, 25, 282–287
 annihilation, 188
 excitons, 295
 of intermediates in bacteria, 346
- Siroheme
 chemical structure, 723
 formation, 764

- Special-pair hypothesis, 22. *See also*
 Bacteriochlorophyll
 criticisms, 324–327
 energy levels, 326
 exciton interpretation, 325
- Spectral forms, of chlorophyll *a* in
 solution
 detection, 709–713
 distribution, 714–716
 putative chemical structure, 719
 reactivity, 713, 714
 relationship to early work, 717, 718
 stability, 713, 714
- Spectral shifts, 49, *see* Absorption change;
 Absorption difference spectrum
- Spectroscopy, *see also* Absorption change;
 Absorption difference spectrum;
 Absorption spectrum
 of carotenoids, 166
 of chlorophylls, 165, 166
 of cytochromes, 164
 of photosynthetic pigments, 164–166
 of proteins, 166
 of quinones, 405
 techniques, 156
- Spheroidene, 89, 90
- Spheroplast, 98, 212
- Spinacia oleracea*, *see* Spinach
- Spinach, 234, 371, 433, 655, 712, 713
 glow curves, 510, 513, 517
- Spirilloxanthin, 90, 91
- Spirillum itersonii*, 763, 764
- Spirulina platensis*, 658, 671, 672, 676
- Spruce, 523
- S-states (O_2 evolution), 452, 453,
 477–489, 530
 proton release, 633
 relation to thermoluminescence, 525–530
 temperature dependence, 527
- Staphylococcus aureus*, 764
- Stark effect, 180, 437
- Stepanov relationship, 309
- Stroma lamellae, 123. *See also* Thylakoid
 membranes
- Structural organization
 of coupling factor enzyme, 552, 553
 orientation of proton producing reac-
 tions, 550, 551
 phosphorylating components, 550–554
 phosphorylating unit, 553, 554
- Succinate dehydrogenase, 73, 74, 401
- Surface potential, 596
 in photosystem II, 418
 in thylakoids, 616–617
- Swiss chard, 235
- Synechococcus lividus*, 446
- T**
- Temperature, effects on delayed light, *see*
 Thermoluminescence
- Tetraphenylboron (TPB), 492
- Thermoluminescence, 507–531
 activation energy, 520
 bands, 509–512, 514–519
 discovery, 508
 frequency factor, 520
 glow peaks, 511, 520
 origin, 521–531
 relation to manganese, 524
 to oxygen evolution, 522–531
 to photosystems, 521
 to S-states, 525–530
- Thiocapsa pfenigii*, 32, 74, 87
- Thiocapsa roseopersicina*, 75, 92, 93
- Thylakoid, *see* Thylakoid membrane
- Thylakoid membrane, *see also* Chloroplast
 membranes
 adhesion, molecular bases, 135–137
 appression, 123, 124
 coupling factor, 635
 electrogenic events, 609–621
 electrogenic reactions, 610
 electron microscopy, 124–132
 after extraction, 714–716
 freeze-etch, 125
 ionic conductivity, 623–625
 model, 119
 morphology, 123–127
 orientation of antenna, 178–180
 pigment, after extraction, 714–716
 pigment proteins, 118–123
 protolytic reactions, 610, 626–634
 proton release, 632–634
 structure, 124–132
- Transition dipoles, geometry, 325
- Transition moment, 179, 188
 carotenoids, 180
 dipoles, geometry, 325
- Transmembrane potential, 615, 616. *See*
also Membrane potential
- Transmission change, *see* Absorption
 change

- Triazine, 112
 Triplet state, 287, 288, 323
 in bacteria, 348–352
 in plants, 406
 Tris ((hydroxymethyl)aminomethane),
 490–492
 Triton X-100, 86, 113
 TSF-I particles, 231, 360, 361, 364, 367
 TSF-II particles, 373, 374
 Two-electron gate, 28, 29
 in bacteria, 408, 409
 in plants, 412–415
- U**
 U (bound quinone), intermediate, 35, 426,
 437
 Ubiquinone, 26, 90, 91, 223
 chemical structure, 390
 E_m , 399
 Q_b (bulk), 432
 spectroscopic properties, 401, 402
 UQ-7, 398
 UQ-10, 398, 402, 445
 Ubiquinone cytochrome c_2 oxidoreductase
 complex, 432, 579
 Ubisemiquinone, 401, 402
 UHDBT (5-*n*-undecyl-6-hydroxy-4,7-diox-
 obenzothiazole), 116, 445
 chemical structure, 391
 use, 423, 424, 427, 428, 434, 449
 Ultrafast flashes, *see* Picosecond
 measurements
 Uncoupler (uncoupling), of phosphoryla-
 tion, *see* specific substance
 UQ-1, 403
 UQ-3, 403
 UQ-7, 398
 UQ-9, 403
 UQ-10, 398, 402, 407
 Uroporphyrinogen III (urogen)
 biosynthesis, 752, 753
 chemical structure, 706
- V**
 Valinomycin, 557, 561, 562, 569, 602,
 620, 621, 624, 654
 Van Niel hypothesis, 19
 Vesicles
 phospholipid, 134
 reconstitution with LHC, 133
- 2-Vinyl-4-ethyl-chlorophyll, 719
 2-Vinyl-4-mono-hydroxyethyl-chlorophyll,
 719
 Vitamin B₁₂, 724
 Voltage probes, extrinsic, 606, 607
- W**
 W, intermediate, 373
 Water
 chemistry, 489–500
 energetics of decomposition, 472, 473
 oxidation, 477
 source of O₂, 9, 471, 472
 substrate for photosynthesis, 471, 472
 Wheat, 522
 Williams' theory, 549, 550
 Woodward's reagent K, 675
- X**
 X, electron acceptor of photosystem I,
 244, 245. *See also* A_{1,2}
 X-320, 253–255, 409–412. *See also* Q, Q_A,
 A_{11,2}
 X-ray
 absorption edge, of manganese com-
 pounds, 496
 crystallography, BChl-protein complex,
 157
 diffraction, 302
 scattering of CF₁, 658, 665
 structure, 303
- Y**
 Y
 electron donor to photosystem II, or
 water-splitting enzyme, *see* Z, in-
 termediate; M, intermediate
 oxygen flash yield, 477, 486
- Z**
 Z-band, thermoluminescence, 510, 511,
 514
 Z-intermediate, electron donor of pho-
 tosystem II, 437, 452, 453, 478
 Z-scheme, 7, 20, 261, 355
 Zea mays, 745, *see also* Maize
 olive necrotic 8147 mutant, 24, 713,
 719, 745
 Zero-mode dominance, 317

- Stuart Coward (editor). DEVELOPMENTAL REGULATION: Aspects of Cell Differentiation, 1973
- I. L. Cameron and J. R. Jeter, Jr. (editors). ACIDIC PROTEINS OF THE NUCLEUS, 1974
- Govindjee (editor). BIOENERGETICS OF PHOTOSYNTHESIS, 1975
- James R. Jeter, Jr., Ivan L. Cameron, George M. Padilla, and Arthur M. Zimmerman (editors). CELL CYCLE REGULATION, 1978
- Gary L. Whitson (editor). NUCLEAR-CYTOPLASMIC INTERACTIONS IN THE CELL CYCLE, 1980
- Danton H. O'Day and Paul A. Horgen (editors). SEXUAL INTERACTIONS IN EUKARYOTIC MICROBES, 1981
- Ivan L. Cameron and Thomas B. Pool (editors). THE TRANSFORMED CELL, 1981
- Arthur M. Zimmerman and Arthur Forer (editors). MITOSIS/CYTOKINESIS, 1981
- Ian R. Brown (editor). MOLECULAR APPROACHES TO NEUROBIOLOGY, 1982
- Henry C. Aldrich and John W. Daniel (editors). CELL BIOLOGY OF *PHYSARUM* AND *DIDYMIUM*, Volume I: Organisms, Nucleus, and Cell Cycle, 1982; Volume II: Differentiation, Metabolism, and Methodology, 1982
- John A. Heddle (editor). MUTAGENICITY: New Horizons in Genetic Toxicology, 1982
- Potu N. Rao, Robert T. Johnson, and Karl Sperling (editors). PREMATURE CHROMOSOME CONDENSATION: Application in Basic, Clinical, and Mutation Research, 1982
- George M. Padilla and Kenneth S. McCarty, Sr. (editors). GENETIC EXPRESSION IN THE CELL CYCLE, 1982
- David S. McDevitt (editor). CELL BIOLOGY OF THE EYE, 1982
- P. Michael Conn (editor). CELLULAR REGULATION OF SECRETION AND RELEASE, 1982
- Govindjee (editor). PHOTOSYNTHESIS, Volume I: Energy Conversion by Plants and Bacteria, 1982; Volume II: Development, Carbon Metabolism, and Plant Productivity, 1982

In preparation

John Morrow. EUKARYOTIC CELL GENETICS, 1983

John F. Hartmann (editor). MECHANISM AND CONTROL OF ANIMAL FERTILIZATION, 1983