



# Nomenclature for *HKT* transporters, key determinants of plant salinity tolerance

J. Damien Platten<sup>1</sup>, Olivier Cotsaftis<sup>2</sup>, Pierre Berthomieu<sup>3</sup>, Hans Bohnert<sup>4</sup>, Romola J. Davenport<sup>5</sup>, David J. Fairbairn<sup>6</sup>, Tomoaki Horie<sup>7</sup>, Roger A. Leigh<sup>5</sup>, Hong-Xuan Lin<sup>8</sup>, Sheng Luan<sup>9</sup>, Pascal Mäser<sup>10</sup>, Omar Pantoja<sup>11</sup>, Alonso Rodríguez-Navarro<sup>12</sup>, Daniel P. Schachtman<sup>13</sup>, Julian I. Schroeder<sup>7</sup>, Hervé Sentenac<sup>3</sup>, Nobuyuki Uozumi<sup>14</sup>, Anne-Aliénor Véry<sup>3</sup>, Jian-Kang Zhu<sup>15</sup>, Elizabeth S. Dennis<sup>1</sup> and Mark Tester<sup>2</sup>

<sup>1</sup> CSIRO Plant Industry, GPO Box 1600, Canberra, ACT 2601, Australia

<sup>2</sup> Australian Centre for Plant Functional Genomics (ACPGF) and University of Adelaide PMB 1, Glen Osmond, SA 5064, Australia

<sup>3</sup> Biochimie et Physiologie Moléculaire des Plantes, UMR 5004, ENSA.M INRA CNRS UMII, 2, place Pierre Viala, 34060 Montpellier Cedex 01, France

<sup>4</sup> Department of Plant Biology, University of Illinois at Urbana-Champaign, 1201 W. Gregory Drive, Urbana IL 61801, USA

<sup>5</sup> Department of Plant Sciences, University of Cambridge, Downing Street, Cambridge CB2 3EA, UK

<sup>6</sup> School of Integrative Biology, John Hines Building, St Lucia Campus, University of Queensland, Brisbane QLD 4072, Australia

<sup>7</sup> Cell and Developmental Biology Section and Center for Molecular Genetics, Division of Biology, University of California, San Diego, 9500 Gilman Drive, La Jolla, CA 92093-0116, USA

<sup>8</sup> National Key Laboratory of Plant Molecular Genetics, Shanghai Institute of Plant Physiology and Ecology, Shanghai Institute for Biological Sciences, The Chinese Academy of Sciences, 300 Fenglin Rd, Shanghai 200032, China

<sup>9</sup> Department of Plant and Microbial Biology, University of California, Berkeley, CA 94720, USA

<sup>10</sup> University of Bern, Institute of Cell Biology, Baltzerstrasse 4, CH-3012 Bern, Switzerland

<sup>11</sup> Departamento Biología Molecular de Plantas, Instituto de Biotecnología, Universidad Nacional Autónoma de México, Apdo. Postal 510-3, Cuernavaca, Morelos 62250, México

<sup>12</sup> Departamento de Biotecnología, Escuela Técnica Superior de Ingenieros Agrónomos, Universidad Politécnica de Madrid, Spain

<sup>13</sup> Donald Danforth Plant Science Center, 975 North Warson Road, St. Louis, MO 63132, USA

<sup>14</sup> Bioscience and Biotechnology Center, Nagoya University, Nagoya 464-8601, Japan

<sup>15</sup> Botany & Plant Sciences, University of California, Riverside, CA 92521, USA

Salinity tolerance in many plants is inversely related to the extent of Na<sup>+</sup> accumulation in the shoot, notably in the major cereals such as wheat and rice [1]. In *Arabidopsis* and rice, there is evidence indicating a central role for members of the *HKT* gene family of Na<sup>+</sup> and Na<sup>+</sup>/K<sup>+</sup> transporters in controlling Na<sup>+</sup> accumulation [2–6] and, thus, in determining salinity tolerance. However, in heterologous systems, whereas the wheat TaHKT1 protein transports both Na<sup>+</sup> and K<sup>+</sup>, AtHKT1 is more Na<sup>+</sup>-specific [7,8] and their sequences are not particularly closely related. Recent studies suggest that members of the *HKT* gene family in rice and *Arabidopsis* are expressed in xylem parenchyma cells and protect leaves from salinity stress by removing sodium from the xylem sap [5,6]. Given the wealth of sequences becoming available and the potential for confusion inherent in the current nomenclature, it is timely to propose an internationally agreed nomenclature for the family.

Phylogenetic trees of publicly available full-length *HKT* coding sequences or *HKT* amino acid sequences show that the gene family splits into two major branches (Figure 1). The major division is stable, as are the clusters of closely related genes, although the precise relationships between gene clusters in the larger subfamily 1 vary slightly with the analysis method used [e.g. minimum-evolution,

neighbor-joining, UPGMA (Unweighted Pair Group Method with Arithmetic Mean) and maximum parsimony]. The two *HKT* subfamilies can also be distinguished on the basis of gene organization (Figure 2). Although all *HKT* genes contain two introns, these are significantly larger in group 1 than in group 2 genes ( $p = 0.0085$ , Mann–Whitney test).

*HKT* genes from dicot species fall within the first major subfamily. By contrast, the nine *HKT* genes found in rice [9] are more diverse and divide between the two major branches. A search of publicly available EST sequences, supplemented by targeted cloning of further members from wheat, barley and sorghum (J.D. Platten and O. Cotsaftis, unpublished) indicates that this family structure is general for many graminaceous species.

It is proposed that the clade containing sequences from dicot species plus the rice *OsHKT4–OsHKT8* genes [9] be designated subfamily 1 (Table 1). Thus, for example, *AtHKT1* becomes *AtHKT1;1* and *OsHKT4* becomes *OsHKT1;1*. The second clade, which so far only contains genes from graminaceous species, is designated subfamily 2. Within these two clades, we propose that genes within a species would be numbered according to the order in which they were identified (or, for those already named, in the current numbering order). For example, *OsHKT9* will now be named *OsHKT2;4*. The revised nomenclature is outlined in Table 1.

Corresponding author: Tester, M. (mark.testers@acpfg.com.au).

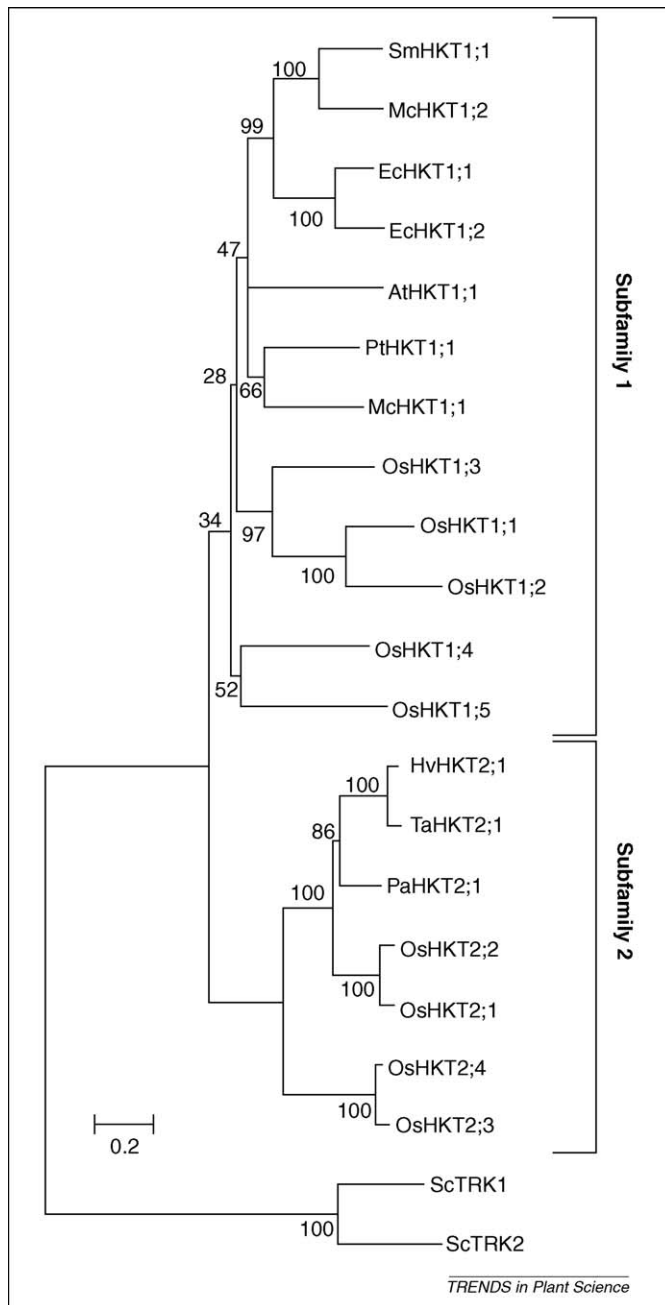

**Figure 1.** Unrooted minimum-evolution tree of known full-length protein sequences encoded by *HKT* genes from higher plants showing the division into two major clades. *Saccharomyces cerevisiae* (Sc) *TRK1* and *TRK2* genes (Accession numbers AAA34728 and AAA35172, respectively) are included as an out-group. Abbreviations: At, *Arabidopsis thaliana*; Ec, *Eucalyptus camaldulensis*; Hv, *Hordeum vulgare*; Mc, *Mesembryanthemum crystallinum*; Os, *Oryza sativa*; Pa, *Phragmites australis*; Pt, *Populus trichocarpa*; Sm, *Suaeda maritima*; Ta, *Triticum aestivum*. The tree was constructed using MEGA3 [15] with a random number seed of 92 702 and 10 000 bootstrap replicates. The numbers indicate percentage bootstrap support. The scale bar indicates 0.2 substitutions per site.

This naming system has the advantages of clearly assigning membership within the gene family to the two functionally and evolutionarily distinct clades – for different members of the family within a species and for similar members of the family from different species. Thus, sequence differences between *TaHKT1* (*TaHKT2;1*) and *AtHKT1* (*AtHKT1;1*) are supported by their separation between the two clades, whereas the similarities between

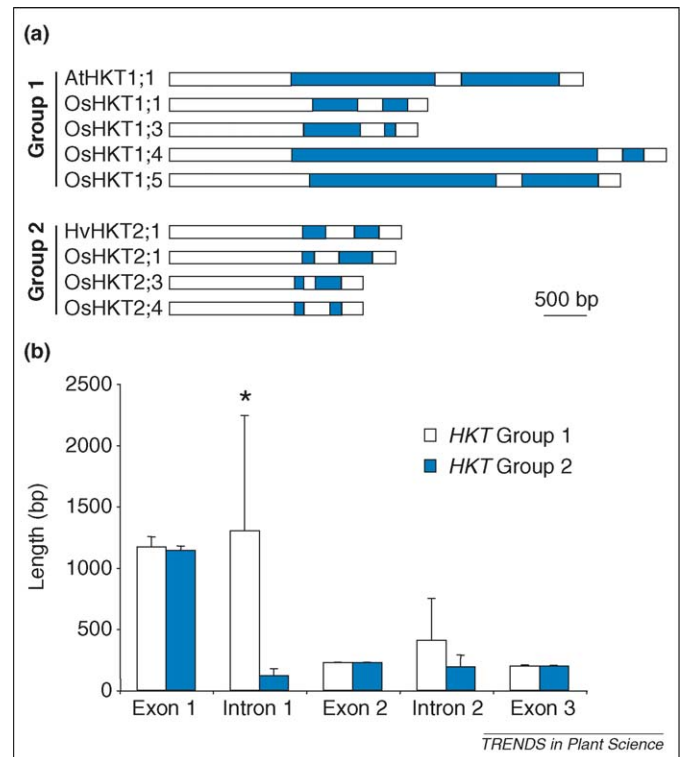

**Figure 2.** The two *HKT* subfamilies have different intron sizes. (a) Structures from the start-to-stop codon of some plant *HKT* genes for which genomic DNA sequences are available. Coding sequences (exons) are depicted in white, introns in blue. All *HKT* genes contain two introns, but they are significantly longer in group 1 than in group 2 genes ( $p = 0.0085$ , two-tailed Mann–Whitney test). (b) Building blocks of plant *HKT* genes for which genomic DNA sequences are available. Although there are no differences in exon sizes, group 1 genes (white;  $n = 5$ ) contain longer introns than group 2 genes (blue;  $n = 4$ ; \*,  $p = 0.016$ , two-tailed Mann–Whitney test).

*TaHKT1* (*TaHKT2;1*) and *OsHKT2* (*OsHKT2;2*) are more clearly indicated. Note that the second number is solely to differentiate genes within a species, and does not reflect relationships – thus, the name *TaHKT2;1* does not indicate a relationship closer to *OsHKT2;1* than to *OsHKT2;3*.

The division of the family into two major branches is associated with a glycine/serine substitution of a residue predicted to be in the first pore loop of the protein [7,9]. All members of subfamily 1 have a serine at this position, whereas members of subfamily 2 (except for the likely revertant *OsHKT2;1*) have a glycine. Functional analyses of the *TaHKT2;1*, *AtHKT1;1* and rice genes suggest that this particular residue could play a central role in determining the  $\text{Na}^+$  selectivity of the transporter [7,9,10], results consistent with those from the related bacterial  $\text{Na}^+$ -dependent  $\text{K}^+$  transporter KtrAB [11]. Therefore, the division into two major subfamilies might reflect an important division of function. There could be other structural determinants of selectivity, which might explain possible effects on selectivity in heterologous systems of the N-terminus [12] and the  $\text{K}^+$  transport activity of *HKT*s from *Eucalyptus* [13,14].

Furthermore, the tree suggests that dicot plants lack members of subfamily 2. The function of these subfamilies and how these genes contribute to salinity tolerance and other aspects of whole-plant function requires further investigation.

Table 1. Revised nomenclature for HKT family members

Previous name	Nucleotide Accession no.	Locus identification no.	Protein Accession no.	Revised name
<b>AtHKT1</b>	AF237672	At4g10310	AAF68393	<b>AtHKT1;1</b>
<b>McHKT1</b>	AF367366	–	AAK52962	<b>McHKT1;1</b>
<b>McHKT2</b>	AY231175	–	AAO73474	<b>McHKT1;2</b>
<b>PtHKT1</b>	grail3 LG_XVIII <sup>a</sup>	–	<sup>a</sup>	<b>PtHKT1;1</b>
<b>EcHKT1</b>	AF176035	–	AAF97728	<b>EcHKT1;1</b>
<b>EcHKT2</b>	AF176036	–	AAD53890	<b>EcHKT1;2</b>
<b>SmHKT1</b>	AY530754	–	AAS20529	<b>SmHKT1;1</b>
<b>OsHKT4</b>	AJ491816	Os04g51820	CAD37183	<b>OsHKT1;1</b>
<b>OsHKT5</b>	AJ506745	–	<sup>b,c</sup>	<b>OsHKT1;2</b>
<b>OsHKT6</b>	AJ491818	Os02g07830	CAD37185	<b>OsHKT1;3</b>
<b>OsHKT7</b>	AJ491853	Os04g51830	CAD37197	<b>OsHKT1;4</b>
<b>OsHKT8, SKC1</b>	AK108663	Os01g20160	BAB93392	<b>OsHKT1;5</b>
<b>TaHKT1</b>	U16709	–	AAA52749	<b>TaHKT2;1</b>
<b>HvHKT1</b>	AM000056	–	CAJ01326	<b>HvHKT2;1</b>
<b>PaHKT1</b>	AB234304	–	BAE44385	<b>PaHKT2;1</b>
<b>OsHKT1</b>	AB061311	Os06g48810	BAB61789	<b>OsHKT2;1</b>
<b>OsHKT2</b>	AB061313	–	BAB61791	<b>OsHKT2;2</b>
<b>OsHKT3</b>	AJ491820	Os01g34850	CAD37187	<b>OsHKT2;3</b>
<b>OsHKT9</b>	AJ491855	Os06g48800	CAD37199	<b>OsHKT2;4</b>

<sup>a</sup>From the poplar genome project, at <http://genome.jgi-psf.org>.

<sup>b</sup>Translated from nucleotide sequence.

<sup>c</sup>Because *OsHKT1;2* is a pseudogene in rice cv. Nipponbare, internal stop codons were overridden to create a full-length amino acid sequence

## References

- Tester, M. and Davenport, R. (2003) Na<sup>+</sup> tolerance and Na<sup>+</sup> transport in higher plants. *Ann. Bot. (Lond.)* 91, 503–527
- Mäser, P. *et al.* (2002) Altered shoot/root Na<sup>+</sup> distribution and bifurcating salt sensitivity in *Arabidopsis* by genetic disruption of the Na<sup>+</sup> transporter *AtHKT1*. *FEBS Lett.* 531, 157–161
- Berthomieu, P. *et al.* (2003) Functional analysis of *AtHKT1* in *Arabidopsis* shows that Na<sup>+</sup> recirculation by the phloem is crucial for salt tolerance. *EMBO J.* 22, 2004–2014
- Rus, A. *et al.* (2004) *AtHKT1* facilitates Na<sup>+</sup> homeostasis and K<sup>+</sup> nutrition in *planta*. *Plant Physiol.* 136, 2500–2511
- Ren, Z.-H. *et al.* (2005) A rice quantitative trait locus for salt tolerance encodes a sodium transporter. *Nat. Genet.* 37, 1141–1146
- Sunardi, *et al.* (2005) Enhanced salt tolerance mediated by *AtHKT1* transporter-induced Na<sup>+</sup> unloading from xylem parenchyma cells. *Plant J.* 44, 928–938
- Mäser, P. *et al.* (2002) Glycine residues in potassium channel-like selectivity filters determine potassium selectivity in four-loop-per-subunit HKT transporters from plants. *Proc. Natl. Acad. Sci. U. S. A.* 99, 6428–6433
- Uozumi, N. *et al.* (2000) The *Arabidopsis* HKT1 gene homolog mediates inward Na<sup>+</sup> currents in *Xenopus laevis* oocytes and Na<sup>+</sup> uptake in *Saccharomyces cerevisiae*. *Plant Physiol.* 122, 1249–1259
- Garcia-deblás, B. *et al.* (2003) Sodium transport and HKT transporters: the rice model. *Plant J.* 34, 788–801
- Horie, T. *et al.* (2001) Two types of HKT transporters with different properties of Na<sup>+</sup> and K<sup>+</sup> transport in *Oryza sativa*. *Plant J.* 27, 129–138
- Tholema, N. *et al.* (2005) All four putative selectivity filter glycine residues in KtrB are essential for high affinity and selective K<sup>+</sup> uptake by the KtrAB system from *Vibrio alginolyticus*. *J. Biol. Chem.* 280, 41146–41154
- Haro, R. *et al.* (2005) HKT1 mediates sodium uniport in roots. Pitfalls in the expression of HKT1 in yeast. *Plant Physiol.* 139, 1495–1506
- Fairbairn, D.J. *et al.* (2000) Characterisation of two distinct HKT1-like potassium transporters from *Eucalyptus camaldulensis*. *Plant Mol. Biol.* 43, 515–525
- Liu, W. *et al.* (2001) Characterization of two HKT1 homologues from *Eucalyptus camaldulensis* that display intrinsic osmosensing capability. *Plant Physiol.* 127, 283–294
- Kumar, S. *et al.* (2004) MEGA3: integrated software for molecular evolutionary genetics analysis and sequence alignment. *Brief. Bioinform.* 5, 150–163